

APPENDIX H-6
BUFFER RAILCAR OPERATION AND
MAINTENANCE INFORMATION

Buffer Railcar Supplemental Maintenance Manual

Prepared by: KASGRO Rail Corporation

REVISION LOG

Rev.	Date	Affected Pages	Revision Description
000	7/14/2017	N/A	Initial Issue
001	01/25/2018	H.6-3, H.6-6, H.6-7 to 18, H.6-20, and all of Appendix C	Removed ECP-60 brake system references and replaced with DB-60 brake system references, and various editorial corrections

WARNING

Failure to follow the instructions contained in this manual or repairing, modifying, and/or altering any component in any manner could result in property damage, severe injury, and/or death.

SUMMARY

This manual covers the basic inspection, operation, and applicable special maintenance issues of the Kasgro Atlas Project 4-axle Flat Buffer Railcar. The railcar is specifically designed for use in a consist of Atlas spent nuclear fuel containment cask railcars.

The railcar maintenance requirements are as listed in Office and Field Manuals of the AAR Interchange Rules.

The areas that differ from standard railcars are brake shoe replacement requirement, brake system maintenance, and truck suspension 12A Adapter Plus™ pads.

TABLE OF CONTENTS

TABLE OF CONTENTS4

LIST OF FIGURES4

1.0 INSPECTION & STORAGE.....5

2.0 BRAKE SHOE REPLACEMENT CRITERIA5

3.0 STORAGE – AXLE ROLLER BEARINGS.....6

4.0 TRUCK MOUNTED BRAKES6

5.0 BRAKE SYSTEM.....6

6.0 BUFFER RAILCAR TRUCK6

APPENDIX A: INSPECTION AND ANNUAL INSPECTION CHECKLIST7

APPENDIX B: MODEL 8500 TRUCK MOUNTED BRAKES INSTALLATION & FIELD
SERVICES INSTRUCTIONS TECHNICAL DATA20

APPENDIX C: MAINTENANCE & REPAIR MANUAL FOR THE BRAKE COMPONENTS.....36

APPENDIX D: MERIDIAN RAIL INSTRUCTION GOVERNING INSPECTION,
MAINTENANCE AND RECLAMATION FOR AMTRAK SWING MOTION
TRUCKS, CIRCULAR NO. 5399-B, REV B..... 115

LIST OF FIGURES

Figure 1: Brake Shoe K.7-5

Figure 2: Center Plate Dimension Key..... K.7-19

1.0 INSPECTION & STORAGE

Railcars used to transport HLRM equipment are to be inspected before each use or as established by OWNER/SHIPPER requirements. Appendix A is an example of an inspection form that should be used as a minimum. An inspection sheet provided by the DOE, a utility, a railcar owner, or a transportation service provider may supersede inspection list Appendix A; however, the replacement inspection list should include all inspection elements of Appendix A.

2.0 BRAKE SHOE REPLACEMENT CRITERIA

The railcars are always to be equipped with 2-inch thick COBRA® TreadGuard® or equivalent brake shoes. These brake shoes have a special composition material and cast iron insert(s).

Due to special truck suspension design requirements for a buffer railcar, brake shoe replacement requirements differ in mandatory replacement thickness of brake shoes from standard replacement requirements, as referenced in Field Manual of A.A.R. Interchange Rules, Rule 12; all other Rule 12 requirements apply.

Maintenance Note: Minimum worn brake shoe replacement thickness is 1 inch including lining and backing plate.

All other causes for renewal are as applicable under Rule 12 titled “Brake Shoes and Shoe Keys”.

FIGURE 1: BRAKE SHOE

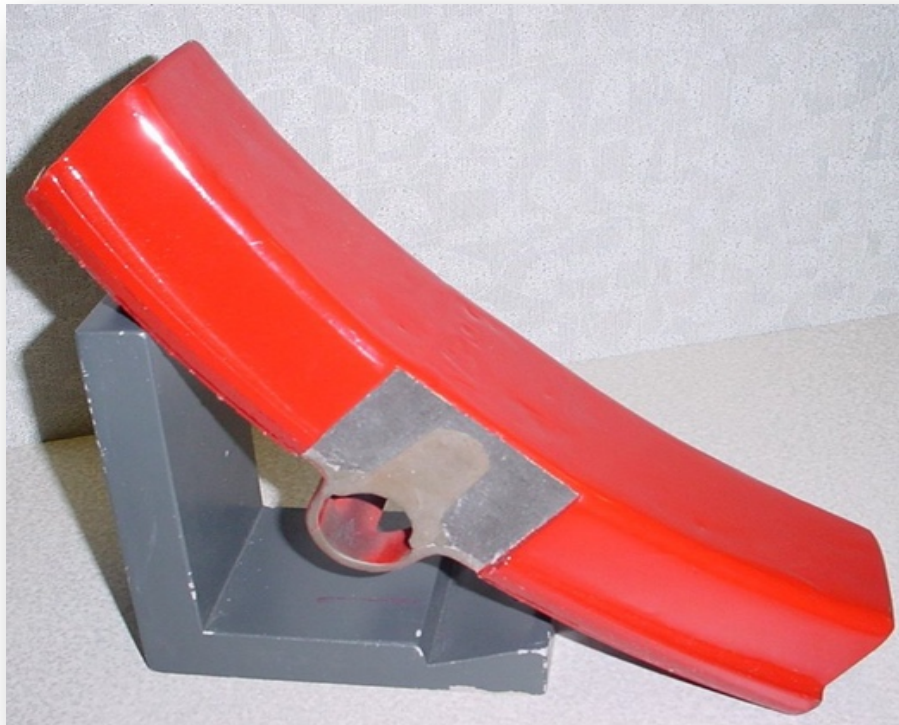

3.0 STORAGE – AXLE ROLLER BEARINGS

When railcars with roller bearings are placed in storage, the brakes should be set and the wheels chocked to prevent the equipment from moving. It is not necessary to periodically move cars or rotate bearings applied to axle assemblies to distribute the lubricant over the bearing surfaces in storage for up to one year. However, if the bearings have remained stationary for one year or more, the car should be moved at least one car length or bearings should be rotated several revolutions on axle assemblies.

If the equipment has been submerged in flood water of such a depth that the water could have entered the bearings, the bearings should be removed and sent to an authorized bearing reconditioning facility. The railcar maintenance requirements, as listed in Office and Field Manuals of the AAR Interchange Rules, may be applicable.

Storage of Wheel and Axle Assemblies with Roller Bearings Applied

Unmounted wheel and axle assemblies with roller bearings applied must be handled with care. Damage may result if the bearings are permitted to strike other objects. Unmounted wheel and axle assemblies with roller bearings applied should not be stored on “double track” also used for the storage of plain bearing axles with wheels mounted (reference AAR Wheel and Axle Manual).

4.0 TRUCK MOUNTED BRAKES

Truck mounted brakes manufactured by Ellcon National are installed on the buffer railcar. Maintenance requirements of the truck mounted brakes are described in *Model 85 Truck Mounted Brakes, Installation & Field Service Instructions Technical Data*, enclosed as Appendix B.

5.0 BRAKE SYSTEM

The Atlas cask and buffer railcar pneumatic brake system is made by New York Air Brake utilizing controller model DB-60. A maintenance and repair manual for the brake components titled *Instruction Pamphlet; Repair Track Maintenance of DB-60 Type Freight Brake Equipment, IP-175, Rev 07* is enclosed for reference. Also enclosed are DB-60 brake component manuals *Maintenance Specification DB-10C Service Portion, P/N 790586 and 789870RC, NYR-481 Rev 02* and *Maintenance Specification DB20 and DB-20L Emergency Portions, P/N 185177/001D, 185177/001L, 775871, 775872, NYR-429, Rev 10*. These documents are enclosed in Appendix C.

6.0 BUFFER RAILCAR TRUCK

The trucks used on the buffer railcar are unique to its design and use. They are the Meridian Rail Global Railway Solutions AMTRAK Swing Motion Trucks. The manual governing the inspection, maintenance and reclamation of these trucks is enclosed as Appendix D and is titled “*Meridian Rail Global Railway Solutions Instruction Governing Inspection, Maintenance and Reclamation for AMTRAK SWING MOTION TRUCKS, Circular No. 5399-B, Rev B*”.

APPENDIX A: INSPECTION AND ANNUAL INSPECTION CHECKLIST

A.1 Buffer Railcar Inspection Checklist Sign-Off

1. Break shoe wear limited to 1-inch as recommended by Ellcon-National.
2. Check the truck friction wedges for wear (*Ref:* Section 2, MeridianRail Amtrak Swing Motion Trucks, Circular No. 5399-B).
3. Perform a visual inspection of the bearing adapters to confirm the restraining tabs have not been damaged.
4. Inspect the truck constant side bearings per AAR-IR, Rule 62.
5. Perform a functional test of the overall brake system. (*Ref.* Section 4, NYAB Instruction Pamphlet IP-175).

<i>BUFFER RAILCAR INSPECTION CHECKLIST SIGN-OFF</i>					
<i>Description of Inspection Item</i>	<i>Recorded Dates, Measurements, or Remarks</i>		<i>Condition**</i>		<i>Signature*</i>
	<i>“A”</i>	<i>“B”</i>	<i>Passed</i>	<i>Discrepant***</i>	
Verify railcars are equipped with bottom-shelf or F-head coupler					
Visually inspect couplers and yokes for cracks, wear, missing sections, distortions					
Broken, bent, cracked or missing knuckle pins					
Side clearance coupler must be capable of movement in a horizontal plane					
Striker castings for cracks or breaks					
End-of-Car Cushioning Units:					
· check for broken springs					
· missing components on restoring mechanism					
· excessive oil leak(s) on carrier plate					
· is cotter pin installed through slotted castle nut					
· inspect & confirm the indicator pin on gas end-of-car cushioning device has acceptable pressure					

BUFFER RAILCAR INSPECTION CHECKLIST SIGN-OFF					
Description of Inspection Item	Recorded Dates, Measurements, or Remarks		Condition**		Signature*
	"A"	"B"	Passed	Discrepant***	
· perform visual inspection for damaged or missing parts in accordance with AAR-IR 59.A					
Check for bent or broken uncoupling levers and proper operation					
Record coupler toggle clearance (REG. ¼" to ½")					
Record height of couplers from top of rail E: 32 ½" – 34 ½" L: 31 ½" – 33 ½"					
Check coupler for worn or distorted contour					
Check coupler shank for wear					
Check for missing, worn, deteriorated, or damaged air brake hoses					
Check and record dates shown on air hose ends					
Check for bent, broken, worn, missing or inoperative brackets, angle cocks, retainer valves, cutout cocks, piping & parts					
Check air hose supports for broken, missing, or bent parts; ensure that the supports maintain the required air hose height					
Check air brake system for operability & loose or defective & audible leaks					
Check brake shoes & shoe keys for missing, broken or missing parts					
Check thickness of brake shoes					
Check brake levers, brake beams, hanger pins, bolts guides & brake connection rods for missing, broken, wear & freedom of movement					
Check all linkages to ensure cotter pins (keys) are in place					

BUFFER RAILCAR INSPECTION CHECKLIST SIGN-OFF					
Description of Inspection Item	Recorded Dates, Measurements, or Remarks		Condition**		Signature*
	“A”	“B”	Passed	Discrepant***	
Ensure brake rigging is not riding on or contacting wheels or axle					
Ensure handbrake(s) is in proper position & operable					
Check for proper operation of on-board bearing temperature monitoring system					
Check for indications of defective roller bearings					
Check truck bolsters & side frames for broken, bent, cracked, patched, wrong size, worn missing & corroded parts					
Visually inspect accessible areas of body bolster, center plate, side & center sills, cross bearers, & jacking pads for cracked or broken parts					
Check and record the side bearing clearance					
Measure and record minimum clearance between railcar & top of rail					
Check for missing, broken, or excessively worn truck side frame friction casting wear plates					
Inspect the side frame to equalizer interface for any evidence of fresh contact					
Ensure railcar deck appears suitable for the intended cradle cask load & attachment blocks are not damaged; if brass insert is installed in attachment blocks visually inspect for damage					
Check wheels for:					
· cracked, broken or chipped flanges					
· cracked, broken, shattered or spread rims					

BUFFER RAILCAR INSPECTION CHECKLIST SIGN-OFF					
<i>Description of Inspection Item</i>	<i>Recorded Dates, Measurements, or Remarks</i>		<i>Condition**</i>		<i>Signature*</i>
	<i>"A"</i>	<i>"B"</i>	<i>Passed</i>	<i>Discrepant***</i>	
· shelled, built-up or grooved tread					
· cracked, broken, dented, or gouged plates					
· overheated wheels					
· thermal cracks & loose wheels					
· worn flanges & flat spots					
· out-of-gage & wrong size					
· broken, missing, & out of position springs & stabilizers					
· Check Hydraulic Stabilizers for leaks, oil level & proper installation					

*User representative verifies, based on personal observation and certifies by his signature/initials in each block that the action has actually been performed in accordance with the specified requirements. Signature required in first block; initials acceptable in all others.

** Place an "X" in the appropriate column.

***List discrepant conditions on separate listing.

Inspection completed, with exceptions as indicated under remarks, and railcar is acceptable in accordance with the requirements of this procedure.

INSPECTOR:

DATE:

Signature of the Railroad representative certifies that the railcar meets the requirements of the AAR and is acceptable for interchange.

RAILROAD REPRESENTATIVE:

DATE:

A.2 Buffer Railcar Annual Inspection Checklist

<i>BUFFER RAILCAR ANNUAL INSPECTION CHECKLIST</i>				
<i>Railcar _____</i>		<i>Container Type & Number _____</i>		
<i>Description of Inspection</i>	<i>AAR-IR Rule No.</i>	<i>B</i>	<i>A</i>	<i>Remarks</i>
1. COUPLER 1. When a coupler is removed from the car, FOR ANY REASON , measure coupler shank length and rear of key slot to shank butt/rear wall thickness; reference Rule 16 fig D, Rule 17 fig A, and Rule 18 fig D. of AAR-IR 2. Grade C coupler bodies may be applied with grade C or grade E draft keys. Grade E coupler bodies must be applied with grade E draft keys only. 3. Grade E locks are correct repairs for ALL couplers	16 & 17			
1.1. Visually Inspect Coupler Parts a. Height – loaded – 31 ½” to 33 ½” b. Alignment – movement of coupler c. Body – wear plate, cracks, bent, wear d. Knuckle – wear, cracks, operation – pin & cotter e. Coupler lock & lock list - operation				
1.2. Inspect Uncoupling Mechanism a. bent, jammed, operation b. proper toggle clearance				
1.3. Check for Prohibited Couplers & Appurtenances				
1.4. Inspect Striker a. Striker – cracks securement, wear & rivets b. Coupler carrier, wear plate – wear, cracked, broken, missing, securement, proper shank clearance				
2. COUPLER CUSHIONING UNITS	59			
2.1. Broken or missing parts a. Inability to assume neutral position b. Restoring mechanism action c. Draft sill weld cracks d. Hydraulic oil leak – must form drips e. Draft key, retained, bolt, wear, missing				

BUFFER RAILCAR ANNUAL INSPECTION CHECKLIST				
<i>Railcar</i> _____		<i>Container Type & Number</i> _____		
Description of Inspection	AAR-IR Rule No.	B	A	Remarks
2.2. Install Keystone push pin EOC-testing device on appropriate EOC cushioning unit which lack it, if a unit must be removed from the car for some other reason				
3. SIDE BEARINGS	61			
3.1. Perform side-bearing inspection in accordance with section 6 of the FIVE-YEAR PM procedure				
3.2. Inspect a. Bearing box – secure, cracked & missing b. Bearing plate – wear, secure, flat & missing c. Rollers – flat spots, cracks, missing d. Clearance – see page ___ of ___ for dimensions				
4. CENTER PLATE	47			
4.1. Perform Center Plate Inspection & Lubrication (CPIL) in accordance with section 5 of the FIVE-YEAR PM inspection procedure				
4.2. Make drawing indicating where repair welding performed, if required, use the comment sheet for the drawing				
5. CAR BODY	88			
5.1. Inspect for cracks, breaks, weld condition, of all car body parts including end sill, center sill stub sills, tie plates, side sill, cross bearer, stringer bolster, etc.				
5.2. Check for prohibited or restricted items				
6. SAFETY EQUIPMENT	88			

BUFFER RAILCAR ANNUAL INSPECTION CHECKLIST				
Railcar _____		Container Type & Number _____		
Description of Inspection	AAR-IR Rule No.	B	A	Remarks
6.1. Inspect a. Ladder – secure, broken, bent, missing b. Platforms – chains, level, no holes, secure condition c. Defect card holder – condition, missing d. Grab irons – secure, bent, missing e. Sill steps – secure, bent, missing f. Handrails – secure, bent, missing, no welds allowed				
7. LIGHT WEIGHT When required lightweight the car	70			
8. TRUCKS & BOLSTERS	47 & 48			
8.1. Inspect a. Side frames & bolsters – cracks, worn, improper repairs b. Side frame key – tight, missing c. Brake beam support – cracks, worn d. Any section worn or corroded greater than 25% e. BUCKEYE 6-wheel truck only – perform side frame equalizer inspection of the FIVE-YEAR PM inspection Procedure				
8.2. No part of the truck shall be less than 2 ¾ inches above top of rail under maximum wear and spring deflection				
9. SPRING ASSEMBLY & SNUBBER	50			
9.1. Inspect a. Springs – broken, cracked, missing, tilted, bottomed-out b. Side frame wear plate – wear, securement, missing c. Bolster wedge – wear, indicator, missing d. Hydraulic stabilizer – oil leak, spring condition, securement, missing				
10. WHEELS & AXLES	41 & 43			

BUFFER RAILCAR ANNUAL INSPECTION CHECKLIST				
<i>Railcar</i> _____		<i>Container Type & Number</i> _____		
Description of Inspection	AAR-IR Rule No.	B	A	Remarks
10.1. Inspect a. Flanges for sharp, high, chipped, overheating or cracking b. Tread – thickness, overheating, groves, flat spots, build-up & shelled c. Plates – cracks, gouges, holes, overheating, other damage d. Axles – bends, rubbing, cracks, gouges & others e. Rim – broken, spread, thin, etc.				
10.2. Check for prohibited wheels & axles				
11. ROLLER JOURNAL BEARINGS	36			
11.1. Bearing inspection as required by Section 2. N/A if not required (AAR Rule 36.A.3a & b., A.10 & 11)				
12. AIR BRAKE SYSTEM	3, 4 & 5			
12.1. Inspect the following for cracks, missing parts, & securement a. Pipe & fittings b. Vent protector c. Reservoirs d. Brake cylinders e. Slack adjusters f. Cut-out cocks & 'U' bolts g. Valves, portions, pipe bracket h. Release valve & rod i. Dirt collector j. Quick service valve k. Vent valve l. Pressure tap m. ECP overlay brake system (see Atlas Cask and Buffer Railcar Supplemental Maintenance Manual Section 5)				
12.2. Inspect hoses, coupling a. Hose – date, cracks, leaks, other damage b. Coupling – damage, gasket, leaks				

BUFFER RAILCAR ANNUAL INSPECTION CHECKLIST				
<i>Railcar</i> _____		<i>Container Type & Number</i> _____		
Description of Inspection	AAR-IR Rule No.	B	A	Remarks
12.3. Perform single car air test in accordance with the AAR Standard S – 486, latest version, after completion of maintenance and the railcar is un-jacked				
12.4. Brake type (ABD, ABDW) stenciled on car				
13. TRUCK & CAR BODY BRAKE RIGGING	6 thru 11			
13.1. Inspect and cause to be corrected if rubbing a. Brake beams – cracks, wear, bends, securement b. Brake rods – cracks, wear, bends c. Levers – cracks, wear, bends, poor alignment d. Pins – wear, AAR approved cotter pins e. Safety hangers – cracks, wear, bends, securement, missing f. Guides – cracks, wear, bends, securement				
13.2. Check for incorrect components				
14. BRAKE SHOES	12			
14.1. Inspect & verify that the proper shoes are on the car a. Composition shoes – minimum thickness 1 inch, includes lining & backing plate				
15. HANDBREAK	13			
15.1. Inspect for defects & proper operation a. Wheel b. Shaft c. Pawl d. Gear e. Trip lever f. Bell crank or Sheave Wheel g. Chain h. Rod i. Guard				

BUFFER RAILCAR ANNUAL INSPECTION CHECKLIST				
<i>Railcar</i> _____		<i>Container Type & Number</i> _____		
Description of Inspection	AAR-IR Rule No.	B	A	Remarks
15.2. Lubricate where required				
15.3. Inspect first 3 visible links painted WHITE or FLORESCENT ORANGE IAW AAR-IR rule 13.E.11				
16. STENCILING	80			
16.1. Stenciling must meet DOT & AAR requirements				
16.2. Stenciling must meet owners reporting marks requirements				
16.3. Ensure the CAR NUMBER is stenciled on the underside of the railcar body OR if already stenciled – that the stencil is readable				

BUFFER RAILCAR ANNUAL INSPECTION CHECKLIST			
Railcar _____		Container Type & Number _____	
SIDE BEARINGS MEASUREMENT DATA SHEET			
PRIOR to Jacking Railcar			
Inspect all four (4) jacking pads IAW 2.1 of this procedure			
Jacking Points	'A' End	L <input type="checkbox"/>	R <input type="checkbox"/>
	'B' End	L <input type="checkbox"/>	R <input type="checkbox"/>
Car Body to Truck	'A' End	L <input type="checkbox"/>	R <input type="checkbox"/>
	'B' End	L <input type="checkbox"/>	R <input type="checkbox"/>
*Applies only to railcars with DOUBLE TRUCKS			
AFTER Jacking Railcar			
Car Body to Truckr	'A' End	L <input type="checkbox"/>	R <input type="checkbox"/>
	'B' End	L <input type="checkbox"/>	R <input type="checkbox"/>
*Applies only to railcars with DOUBLE TRUCKS			

SIDE BEARINGS CLEARANCE MEASUREMENT RANGE

1. RAILCAR BODY TO TRUCK: 4 wheeled trucks – average of the two should be between $\frac{3}{16}$ " and $\frac{5}{16}$ "

BUFFER RAILCAR ANNUAL INSPECTION CHECKLIST			
<i>Railcar</i> _____		<i>Container Type & Number</i> _____	
CENTER PLATE BEARING DATA SHEET			
'A' END OUTSIDE DIAMETERS for the following CAR BODY [1] LARGE O.D.	'A' END INSIDE DIAMETERS for the following TRUCK [2] LARGE I.D.	'B' END OUTSIDE DIAMETERS for the following CAR BODY [1] LARGE O.D.	'B' END INSIDE DIAMETERS for the following TRUCK [2] LARGE I.D.
1 _____ 2 _____	1 _____ 2 _____	1 _____ 2 _____	1 _____ 2 _____
3 _____ 4 _____	3 _____ 4 _____	3 _____ 4 _____	3 _____ 4 _____
USE FIGURE 2 CENTER PLATE DIMENSION KEY, TO ASSIST WITH THE PROPER DATA PLACEMENT AFTER MEASURING THE ID's AND THE OD's COMPARE THE CLEARANCES THE MINIMUM IS $\frac{1}{8}$ " AND THE MAXIMUM IS $\frac{1}{2}$ "			

Inspection completed, with exceptions as indicated under remarks, and railcar is acceptable in accordance with the requirements of this procedure.

INSPECTOR: _____ *DATE:* _____

Signature of the Railroad representative certifies that the railcar meets the requirements of the AAR and is acceptable for interchange.

RAILROAD REPRESENTATIVE: _____ *DATE:* _____

VISUAL AID TO IDENTIFY PROPER RECORDING OF BOLSTER INSIDE AND OUTSIDE DIAMETERS IN THE 5 YEAR PM.
MATCH THESE NUMBERS WITH THOSE ON THE CENTER PLATE BEARING DATA SHEET CHECKLIST.

FIGURE 1: CENTER PLATE DIMENSION KEY

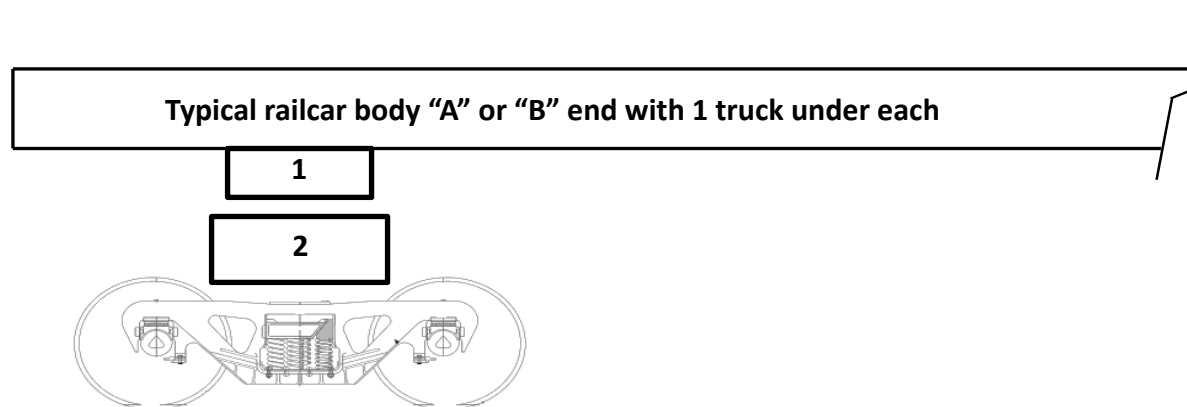

APPENDIX B: MODEL 8500 TRUCK MOUNTED BRAKES INSTALLATION & FIELD SERVICES INSTRUCTIONS TECHNICAL DATA

Model 8500 Truck Mounted Brakes Installation & Field Service Instructions Technical Data

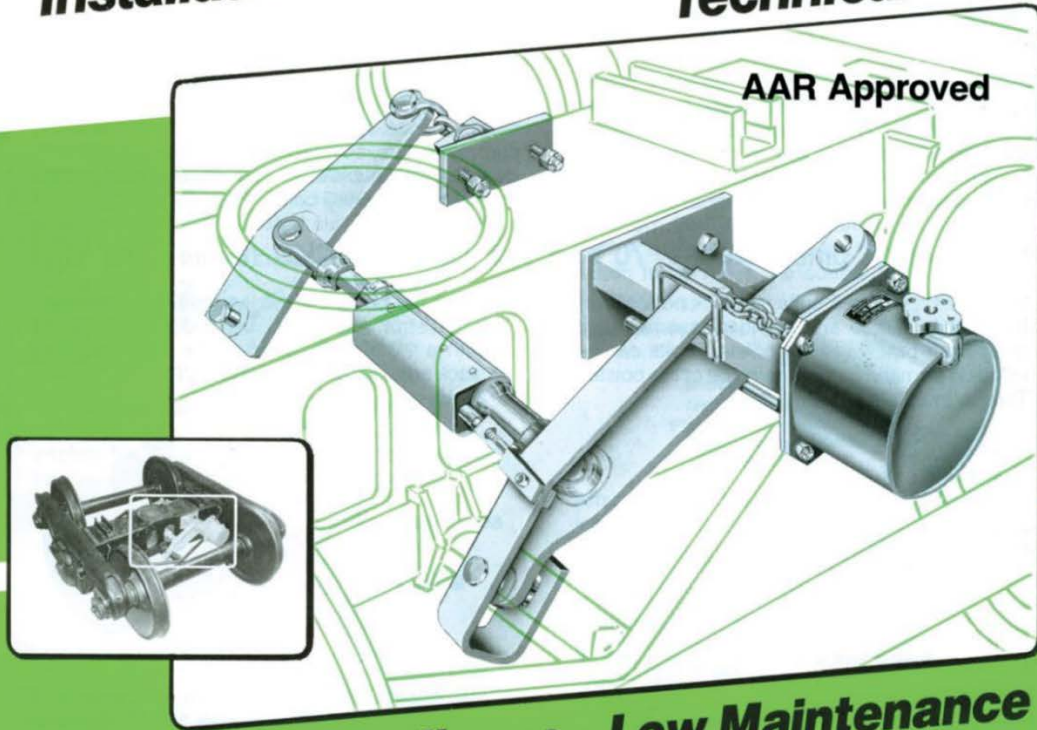

Rugged • High Mileage • Low Maintenance
70, 100 & 125 Ton Capacity

Corrosion-Resistant Piston and Cylinder

- Uses Standard Bolster.
- Uses Standard Brake Beams.
- Uses Standard Brake Cylinder Packing Cup.
- No Loss in Brake Shoe Force Due to Shoe and Wheel Wear, as Double Acting Slack Adjuster Maintains Constant Piston Travel.



Bulletin TMBIM05



50 Beechtree Blvd., P.O. Box 9377 • Greenville, SC 29604-9377
Phone: 864-277-5000 • FAX: 864-277-5207

GENERAL DESCRIPTION

The Ellcon-National Model 8500 Truck Mounted Brake consists of an air brake cylinder, two truck levers (three when a hand brake multiplying lever is required), an automatic double acting slack adjuster, mounting brackets, an actuator lever, and associated hardware, all installed on a standard three piece A.A.R. truck. The units are rugged, proven low maintenance, and have corrosion-resistant piston and cylinder.

The cylinders are available in three sizes: 7-1/2", 8-1/2", and 10" diameter for application on 70, 100, and 125 ton trucks. The truck mounted brake can be attached to the bolster in one of two ways: Bolted to the vertical face (direct mount, Figures 1 & 2), or with a saddle mount assembly (Figure 3) for cars

using reconditioned bolsters. There is also a third lever design that can be added to any truck mounted brake to increase the hand brake force (Figure 4).

The truck mounted brake can be supplied as a left (-L) or a right hand (-R) model. This allows the cylinder to be mounted to either side of the bolster.

There are several brake lever ratios used in combination with the cylinder sizes to meet all A.A.R. braking requirements.

As of 12/31/05 there are more than 129,000 truck sets in service. These units have been applied to log cars, tank cars, covered hopper cars, open hopper cars, five unit double stack intermodal container cars, and stand alone well cars.

INSTALLATION, DIRECT MOUNT 70 and 100 TON TRUCKS (Figure 1 - Pg. 10)

- A. With the 1", Grade 5 bolts and lock nuts, attach the bolster saddle and cylinder assembly and dead lever bracket to the bolster. Bolts can be installed from the outside or inside of the bolster. Torque to 250-300 ft./lbs.

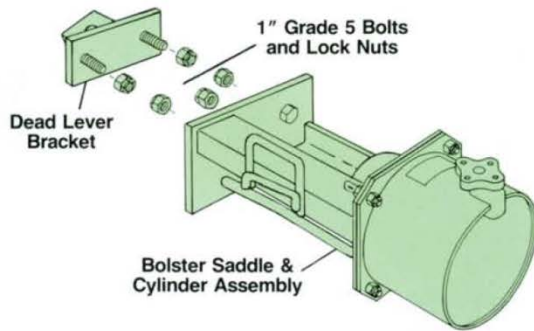

- B. Lay the slack adjuster in the brake rod hole of the bolster with the trigger end towards the cylinder.

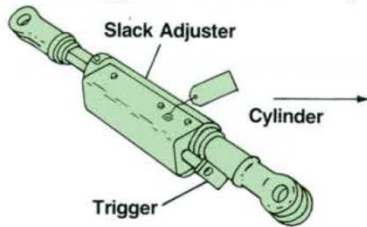

- C. Insert the push rod into the hollow sleeve of the piston.

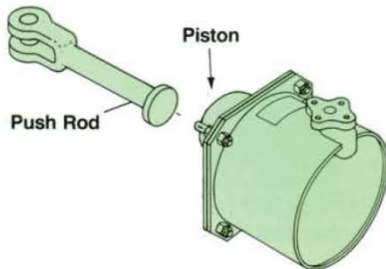

- D. Insert the bottom of the live lever into the brake beam strut. Attach the push rod to the live lever with a 1-3/32" dia. short brake pin. Attach the slack adjuster to the live lever with a 1-7/32" dia. brake pin.

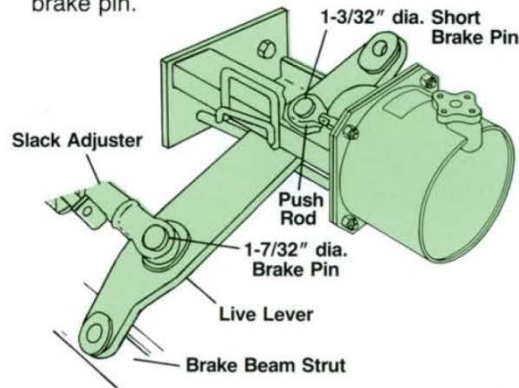

- E. Attach the chain and shackle to the actuator lever.

- F. Apply the actuator lever with the "U" end straddling the brake beam strut and the opposite end with the chain and shackle attached going through the actuator lever guide. Insert the long brake pin through the actuator lever, brake beam strut, and live lever.

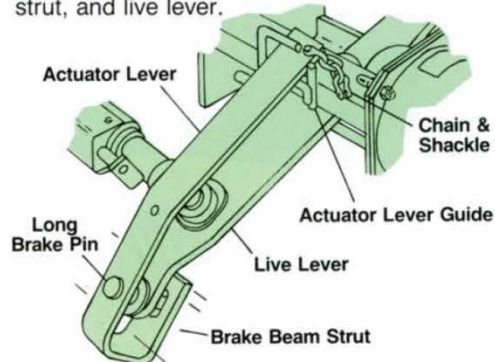

G. Insert the dead lever through the slack adjuster jaw and into the brake beam strut and pin with a 1-3/32" dia. brake pin (1-11/32" dia. on No. 24 brake beams).

H. Attach the slack adjuster to the dead lever with a 1-7/32" dia. brake pin.

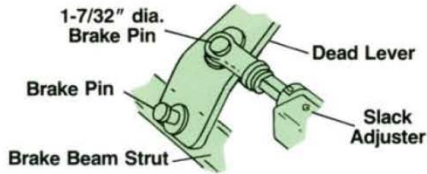

J. Connect the dead lever to the dead lever bracket with two clevises using two 1-3/32" dia. brake pins. Attach the 90° twisted clevis to the dead lever.

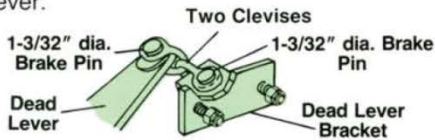

K. Attach the chain and shackle to the eye bolt on 7-1/2" and 8-1/2" dia. cylinders and to the anchor for 10" dia. cylinders on front of the bolster saddle and cylinder assembly.



L. Insert the threaded end of the control arm through the trigger hole. Attach the jaw end to the actuator lever with a 3/4" dia. brake pin or 3/8" shoulder bolt and lock nut depending on the application. (see pg. 9)

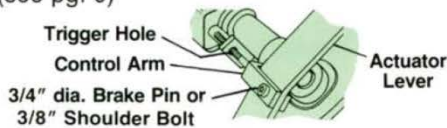

M. Apply the control arm nut and lock nut to the control arm. Run the control arm nut to within 1/4" of the trigger.

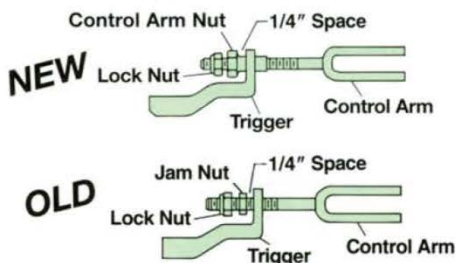

NOTE: Brake shoes and brake keys should be in at this time.

N. Remove the shipping bolt from the slack adjuster, identified by a blue warning tag.

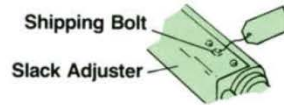

NOTE: Truck spring height should be 10" ± 1/4" to set up piston travel; if not system might act sluggish.

P. Attach the cylinder hose to the 1/2" flange of cylinder and apply 50 lbs. of air to the cylinder; set and release several times. The piston travel should be 2-3/4" ± 1/4"; measured from front of cylinder non-pressure plate to end of piston. If it is not, adjust as follows with the brakes released: For longer piston travel move the control arm nut away from the trigger. For shorter piston travel move the control arm nut toward the trigger.

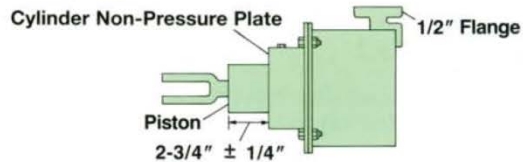

Q. After obtaining the correct piston travel, run the lock nut up to the control arm nut and tighten them together to prevent moving in service.

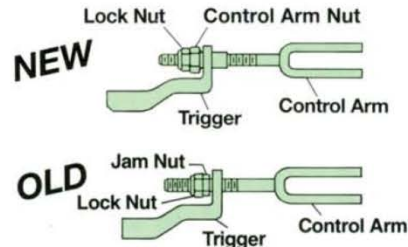

R. Apply the cotter pins to all the brake pins. Be sure the brake pin washer is on the long brake pin before applying the cotter pin.



NOTE: On models manufactured after August of 1993, there is a piston travel indicator welded to the bolster saddle that indicates the operating range from 2-1/4" to 4".

S. The two piston travel indicator decals should be applied to each side of the car in the area of the cylinder.



INSTALLATION, DIRECT MOUNT 125 TON TRUCKS (Figure 2 - Pg. 11)

A. With the 1", Grade 5 bolts and lock nuts, attach the bolster saddle and cylinder assembly and dead lever bracket to the bolster. Bolts can be installed from the outside or inside of the bolster. Torque to 250-300 ft./lbs.

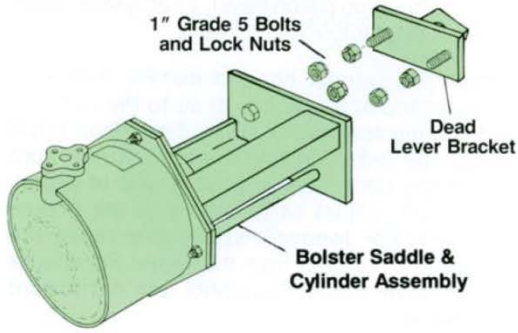

D. Insert the bottom of the live lever into the brake beam strut. Attach the push rod to the live lever with a 1-3/32" dia. short brake pin. Attach the slack adjuster to the live lever with a 1-7/32" dia. brake pin.

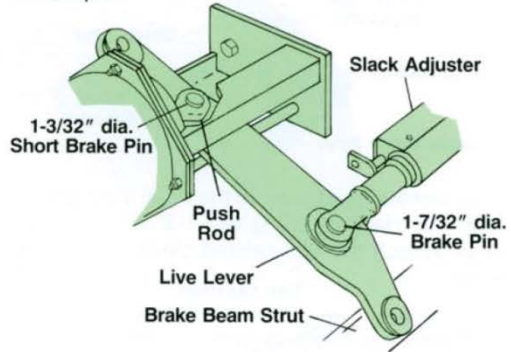

B. Lay the slack adjuster in the brake rod hole of the bolster with the trigger end towards the cylinder.

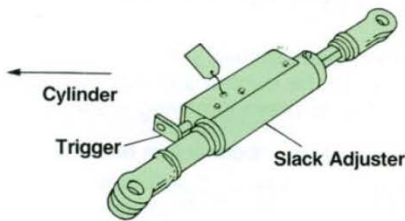

E. Attach the chain and shackle to the actuator lever.

F. Apply the actuator lever with the "U" end straddling the brake beam strut and the opposite end with the chain and shackle attached going through the actuator lever guide. Insert the 1-11/32" dia. long brake pin through the actuator lever, brake beam strut, and live lever.

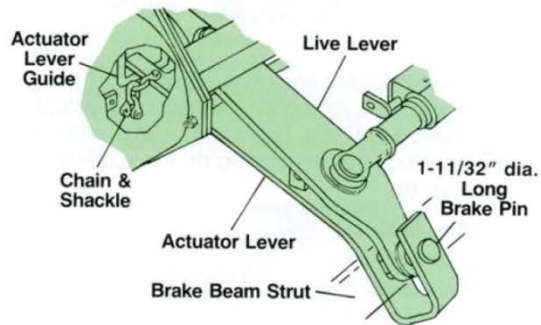

C. Insert the push rod into the hollow sleeve of the piston.

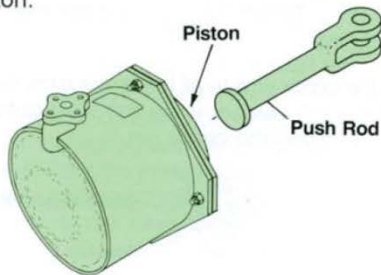

G. Insert the dead lever through the slack adjuster jaw and into the brake beam strut and pin with a 1-11/32" dia. brake pin.

H. Attach the slack adjuster to the dead lever with a 1-7/32" dia. brake pin.

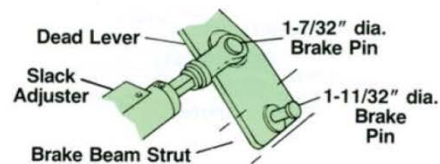

- J. Connect the dead lever to the dead lever bracket with two clevises using two 1-3/32" dia. brake pins. Attach the 90° twisted clevis to the dead lever.

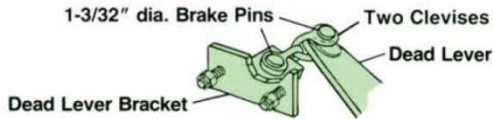

- K. Attach the chain and shackle to the anchor on front of the bolster saddle and cylinder assembly.



- L. Insert the threaded end of the control arm with the washer, first through the trigger and then through the control arm bracket on the actuator lever.

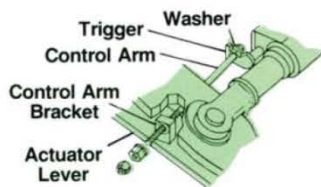

- M. Apply the control arm nut and lock nut to the control arm. Run the control arm nut to within 1/4" of the trigger.

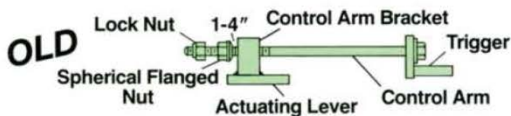
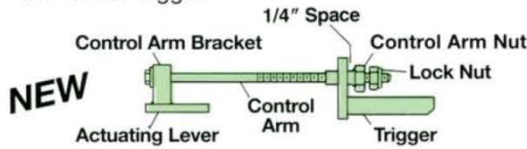

NOTE: Brake shoes and brake keys should be in at this time.

- N. Remove the shipping bolt from the slack adjuster, identified by a blue warning tag.



NOTE: Truck spring height should be 10" ± 1/4" to set up piston travel; if not system might act sluggish.

- P. Attach the cylinder hose to the 1/2" flange of cylinder and apply 50 lbs. of air to the cylinder; set and release several times. The piston travel should be 2-3/4" ± 1/4"; measured from front of cylinder non-pressure plate to end of piston. If it is not, adjust as follows with the brakes released: For longer piston travel move the control arm nut away from the trigger. For shorter piston travel move the control arm nut toward the trigger.

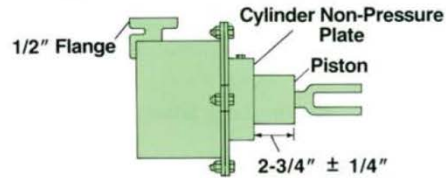

- Q. After obtaining the correct piston travel, run the lock nut up to the control arm nut and tighten them together to prevent moving in service.

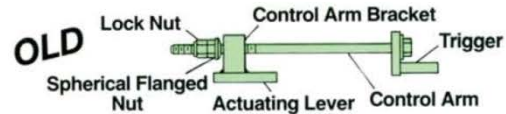
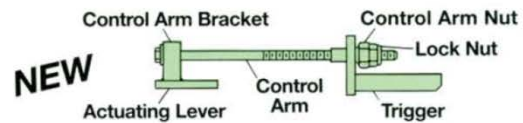

- R. Apply the cotter pins to all the brake pins. Be sure the brake pin washer is on the long brake pin before applying the cotter pin.

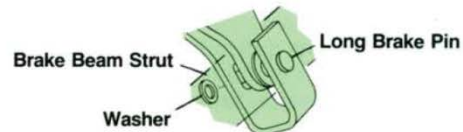

NOTE: On models manufactured after August of 1993, there is a piston travel indicator welded to the bolster saddle that indicates the operating range from 2-1/4" to 4".

- S. The two piston travel indicator decals should be applied to each side of the car in the area of the cylinder.

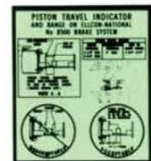

INSTALLATION, SADDLE MOUNT (Figure 3 - Pg. 12) 70 and 100 TON TRUCKS

A. With the 1" Grade 5 inside bolt, outside bolt, and lock nuts, assemble the bolster saddle and cylinder assembly, dead lever bracket, and short and long spacer (this can be done on or off the bolster).

NOTE: The yellow painted side of the spacers should be assembled **towards** the side frame.

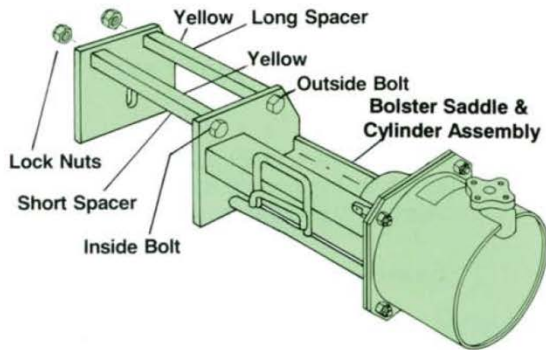

B. Locate this assembly using a locating fixture or per the dimension shown on the truck mounted brake application drawing.

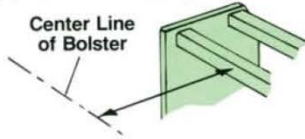

C. Assemble the two washers and the 1" Grade 5 center bolt through the saddle plate, dead lever bracket, and the lightener hole in the bolster. Hand tighten the lock nut. Pull the center bolt up against the top of the lightener hole using the center bolt assembly fixture or any other method.

D. Tighten the three lock nuts, torquing them to 250-300 ft./lbs., doing the center bolt first.

E. Tack weld the two washers, with the center bolt in place, to the dead lever bracket and the saddle plate.

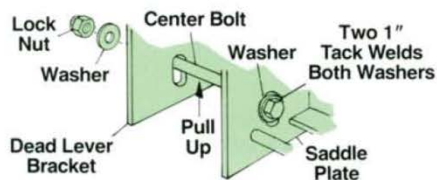

F. Lay the slack adjuster in the brake rod hole of the bolster with trigger end towards the cylinder.

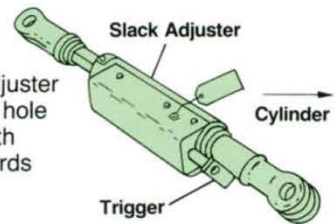

G. Insert push rod into the hollow sleeve of the piston.

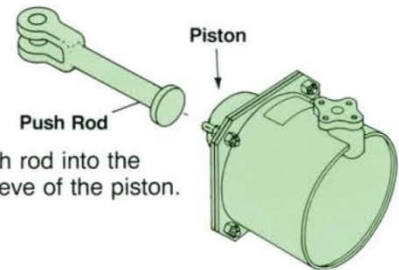

H. Insert the bottom of the live lever into the brake beam strut. Attach the push rod to the live lever with a 1-3/32" dia. short brake pin. Attach the slack adjuster to the live lever with a 1-7/32" dia. brake pin.

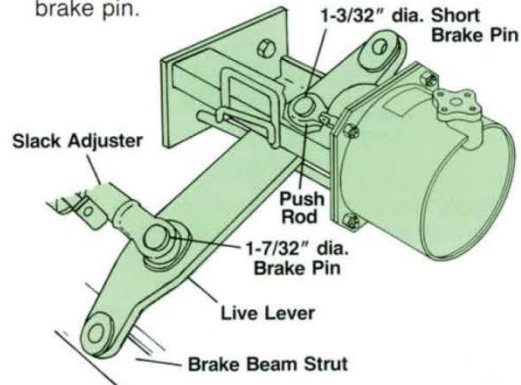

J. Attach the chain and shackle to the actuator lever.

K. Apply the actuator lever with the "U" end straddling the brake beam strut and the opposite end with the chain and shackle attached going through the actuator lever guide. Insert the long brake pin through the actuator lever, brake beam strut, and live lever.

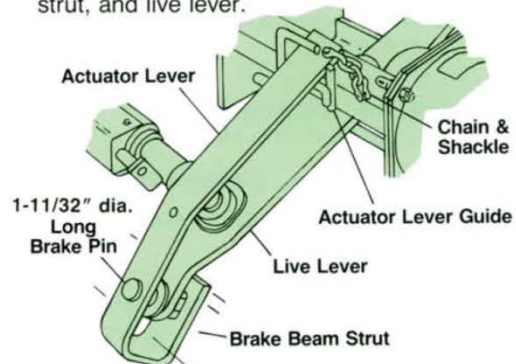

L. Insert the dead lever through the slack adjuster jaw and into the brake beam strut and pin with a 1-3/32" dia. brake pin (1-11/32" dia. on No. 24 brake beams).

M. Attach the slack adjuster to the dead lever with a 1-7/32" dia. brake pin.

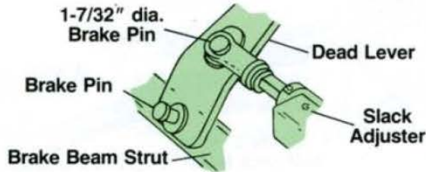

N. Connect the dead lever to the dead lever bracket with two clevises using two 1-3/32" dia. brake pins. Attach the 90° twisted clevis to the dead lever.

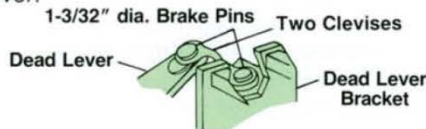

P. Attach the chain and shackle to the eye bolt on 7-1/2" and 8-1/2" dia. cylinders and to the anchor for 10" dia. cylinders on front of the bolster saddle and cylinder assembly.

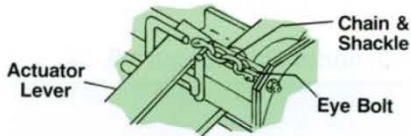

Q. Insert the threaded end of the control arm through the trigger hole. Attach the jaw end to the actuator lever with a 3/4" dia. brake pin or 3/8" shoulder bolt and lock nut depending on the application. (see pg. 9).

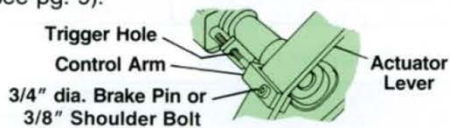

R. Apply the control arm nut and lock nut to the control arm. Run the control arm nut to within 1/4" of the trigger.

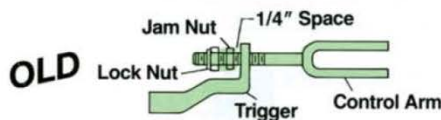
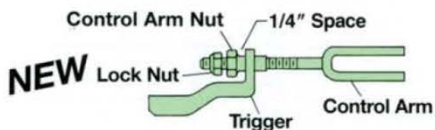

NOTE: Brake shoes and brake keys should be in at this time.

S. Remove the shipping bolt from the slack adjuster, identified by a blue warning tag.

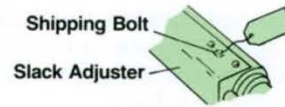

NOTE: Truck spring height should be 10" ± 1/4" to set up piston travel; if not system might act sluggish.

T. Attach the cylinder hose to the 1/2" flange of cylinder and apply 50 lbs. of air to the cylinder; set and release several times. The piston travel should be 2-3/4" ± 1/4"; measured from front of cylinder non-pressure plate to end of piston. If it is not, adjust as follows with the brakes released: For longer piston travel move the control arm nut away from the trigger. For shorter piston travel move the control arm nut toward the trigger.

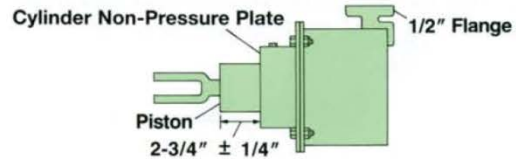

U. After obtaining the correct piston travel, run the lock nut up to the control arm nut and tighten them together to prevent moving in service.

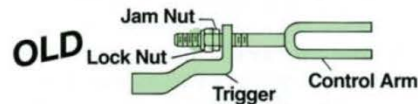
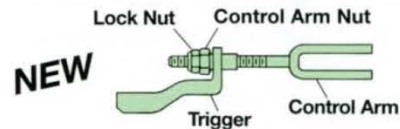

V. Apply the cotter pins to all the brake pins. Be sure the brake pin washer is on the long brake pin before applying the cotter pin.



NOTE: On models manufactured after August of 1993, there is a piston travel indicator welded to the bolster saddle that indicates the operating range from 2-1/4" to 4".

W. The two piston travel indicator decals should be applied to each side of the car in the area of the cylinder.



**INSTALLATION, THIRD LEVER
 (Figure 4 - Pg. 13)**

Any third lever type truck mounted brake should be installed per the previously mentioned truck mounted brake installation procedures except as follows:

- A. The dead lever bracket is attached to the bolster with three 1" Grade 5 bolts and lock nuts instead of two on direct mount truck mounted brakes.

NOTE: Before adjusting piston travel and applying air, the following parts should be installed.

- B. Connect the multiplying lever to the dead lever bracket with a 1-3/32" dia. brake pin.
- C. Connect the pull rod to the live lever with a 1-3/32" dia. brake pin.
- D. Insert the large clevis through the end of the pull rod and connect to the center hole of the multiplying lever with a 1-3/32" dia. brake pin.

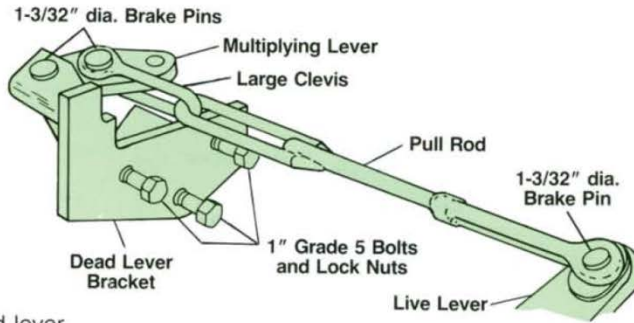

NOTE: Now attach cylinder hose, adjust piston travel, tighten control arm nuts, and apply cotter pins making sure the washer is on the long brake pin as previously instructed in these instructions.



HAND BRAKE

On conventional two truck 70 ton or 100 ton cars there are two hand brakes that can be used.

- A. Group "O" with a No. 66 bell crank connected directly to live lever (Figures 1, 2, and 3).
- B. Or a Group "N" using a sheave wheel with the chain connecting the third lever at the dead lever bracket (Figure 4). Both the above are connected to one of the two trucks. On multi-unit cars or stand alone well cars where the hand brake rigging is connected to two or more trucks, a Group "O" hand brake with a sheave wheel must be used because of the required chain take up of the hand brake.

On all cars enough slack should be designed into the horizontal chain so that the car can negotiate a 180 ft. or 150 ft. radius curve.

BRAKE SHOE CHANGE OUT

To replace worn brake shoes insert a pry bar between the brake shoe and the wheel and pry the shoe away from the wheel, thus shortening the slack adjuster. Remove the worn shoe and apply a new 2" composition shoe. Secure with brake shoe key. If more than one shoe has to be replaced repeat the procedure. Proper brake shoe clearance will be obtained when brakes are set and released allowing the slack adjuster to function.

Brake Cylinder Data (Figure 5, 5A, 6 & 6A)

Cylinder Size (inches)	Piston Travel @ 65 PSI Nominal (inches)	Brake Cylinder Clearance Volume (cubic inches)	Brake Cylinder Volume (cubic inches)	Maximum Piston Stroke (inches)
7½	2¾	11.6	121.5	4¾
8½	2¾	13.0	156.0	5
9	2¾	21.8	175.0	5
10	2¾	25.5	216.0	5

Brake Cylinder Forces

Cylinder Size (inches)	Piston Travel @ 65 PSI Nominal (inches)	Brake Cylinder Output @ 65 PSI	Brake Lever Ratio Per Truck	Shoe Force Per Truck @ 82% EFF. (Pounds @ 65 PSI)
7½	2¾	2872#	3.75 to 1	8,831
7½	2¾	2872#	3.92 to 1	9,232
8½	2¾	3688#	3.75 to 1	11,341
8½	2¾	3688#	3.92 to 1	11,855
9	2¾	4135#	3.75 to 1	12,715
9	2¾	4135#	3.92 to 1	13,292
10	2¾	5105#	3.92 to 1	16,410
10	2¾	5105#	4.48 to 1	18,754



FIELD INSPECTION (Figures 1, 2, 3, & 4)

Visually inspect that the brake pins and cotter pins are in place. Check that the brake levers, slack adjuster, actuator lever, brake beams, cylinder, clevises, and mounting brackets are not damaged or missing. Replace in kind as required.

Check for shoe clearance by prying the brake shoe away from the wheel — the shoe should stay back. If the shoe springs back against the wheel check that the hand brake is fully released and that the push rod has fully returned allowing the slack adjuster to return to the release position (see below). After doing the above, if the slack adjuster trigger does not return, check that the nuts on the control arm have not been over adjusted, holding the trigger out. If they have, back off the nuts allowing the trigger to return to the released position. Shoe clearance should now be available.

To verify that the system is functioning properly, make two brake applications, record the piston travel (2-3/4" ± 1/4") and the slack adjuster extension length after the second application. Release the brakes; insert a block between the shoe and the wheel. Apply air twice. Piston travel should be approximately the same. The slack adjuster extension should be shorter. Release the brakes, remove block, apply air twice, and both the piston travel and extension should be approximately the same as the initial setting.

NOTE: If for some reason the slack adjuster trigger will not return and the spring load remains in the brake system, carefully drive out the brake pin at the dead lever bracket assembly staying clear of the lever

as it may jump away from the bolster. The slack adjuster can now be removed and a new one applied.

AVAILABLE UPGRADES FOR OLDER CARS

1. An actuator lever guide with a wear pad and a wear bar can be welded to the top angle brace of the bolster weldment. A 1/2" thick bar welded to the actuator lever will increase the bearing area between the actuator lever and the actuator lever guide. (Drawing C-33214)

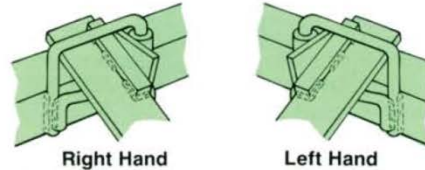

2. A 3/4" bar can be added to any dead lever bracket that has a clevis attachment welded vertically to prevent the dead lever from dropping to low in service thus causing possible contact between the slack adjuster and brake beam. (Drawing C-31924)

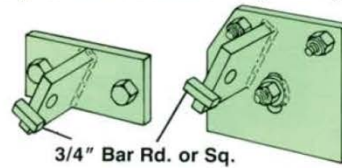

3. A piston travel indicator can be added to older truck mounted brakes. (Drawing A-33167)

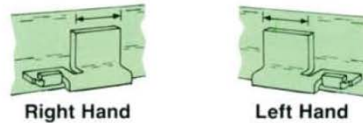

SLACK ADJUSTER . . . Series 7100

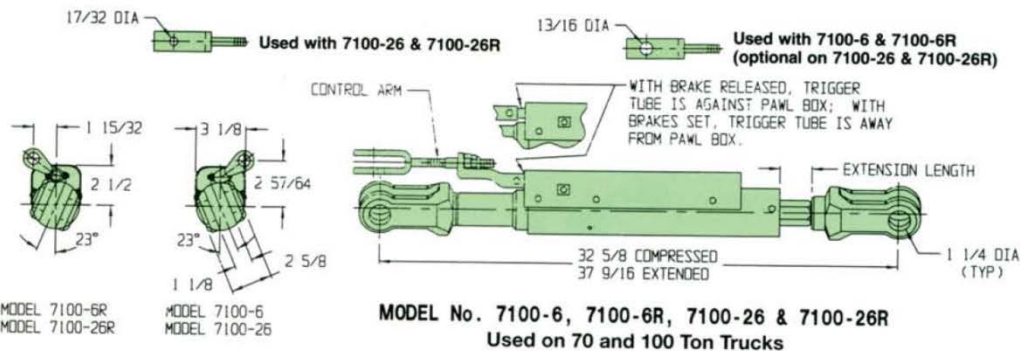
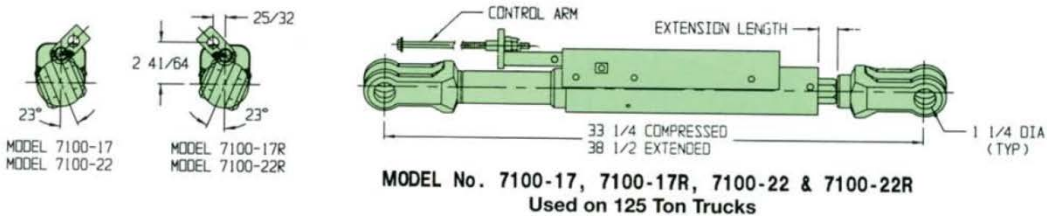

Ellcon-National Truck Mounted Brake . . Model 8500 . .

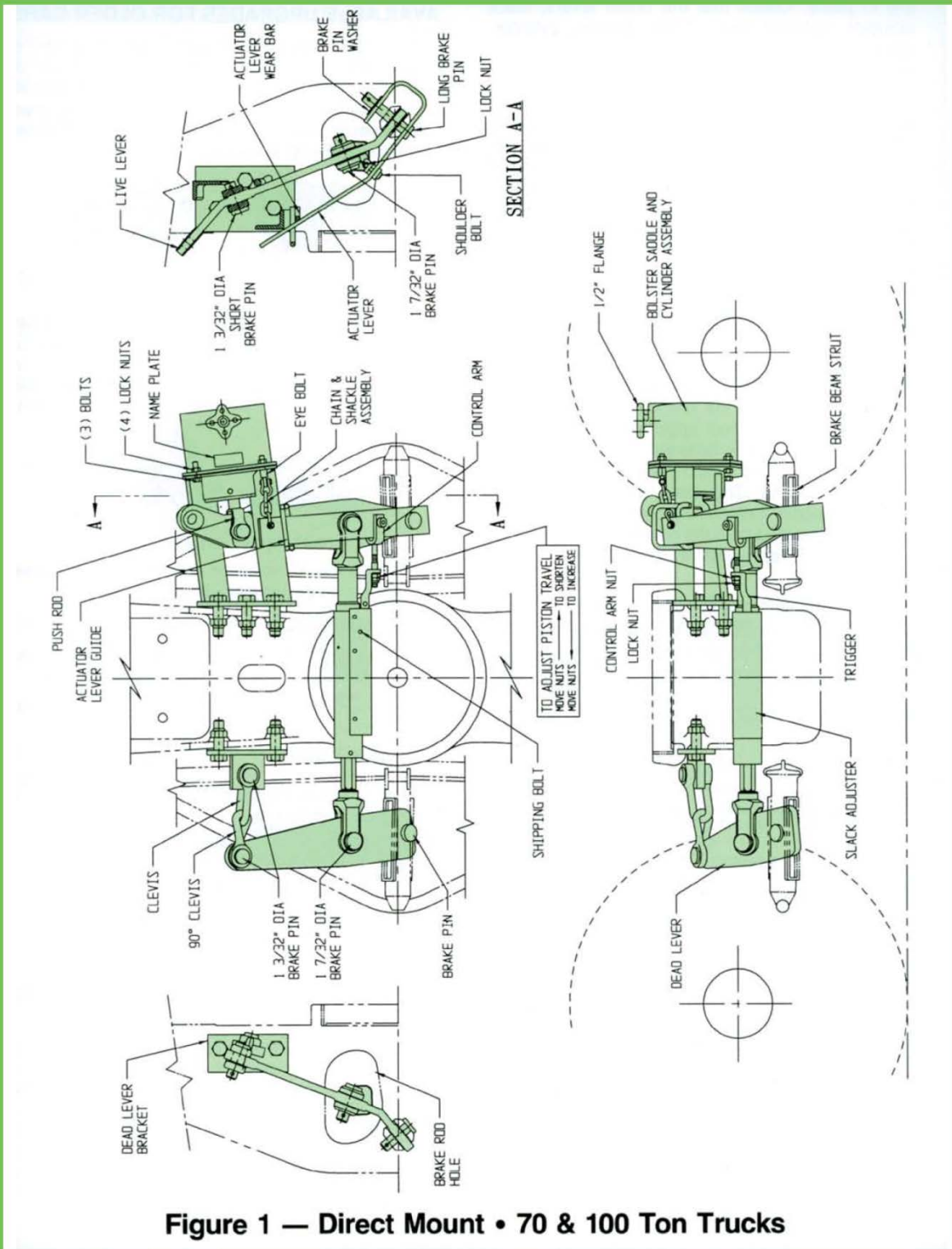

Figure 1 — Direct Mount • 70 & 100 Ton Trucks

... with automatic double acting slack adjuster

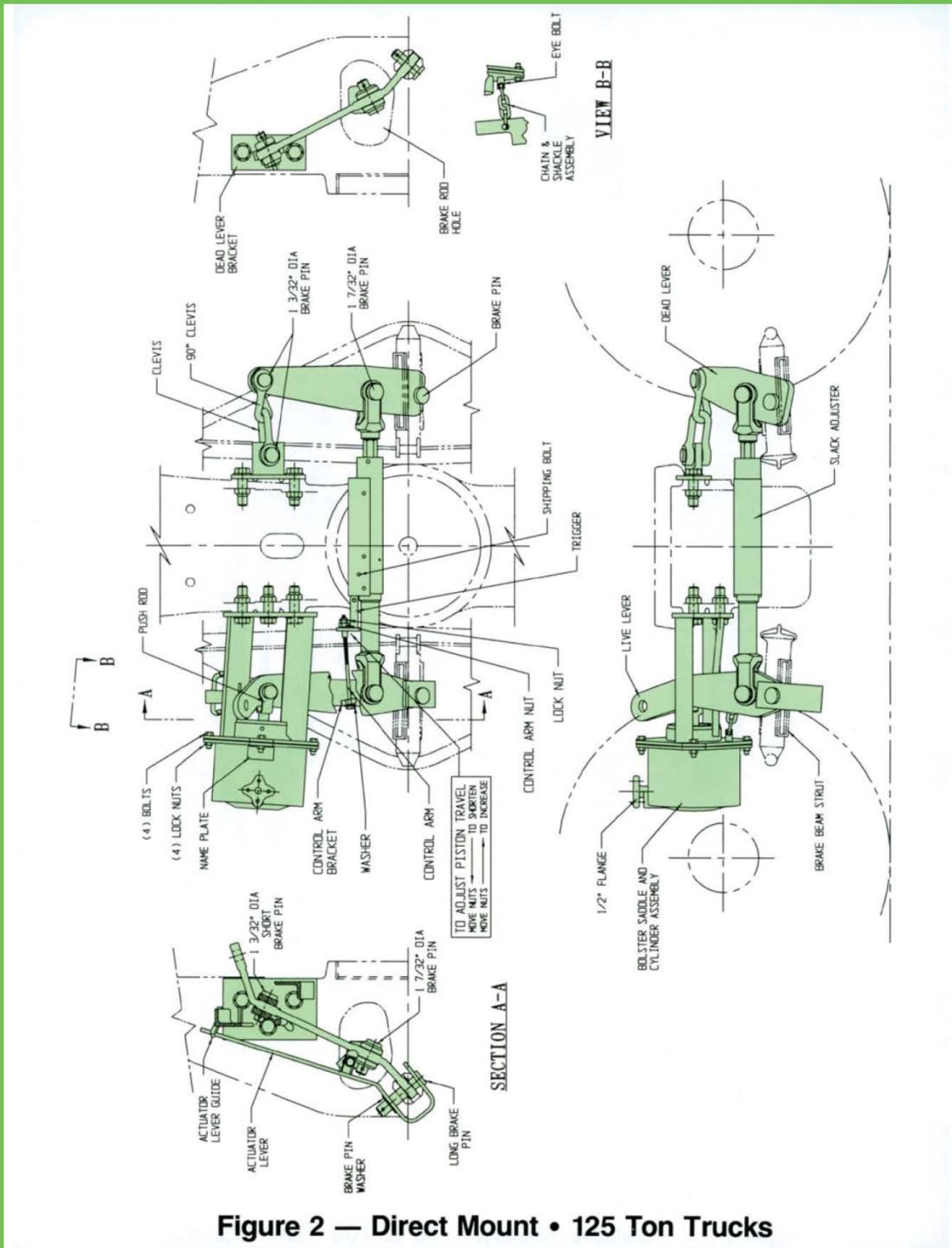

Figure 2 — Direct Mount • 125 Ton Trucks

Ellcon-National Truck Mounted Brake . . . Model 8500 . . .

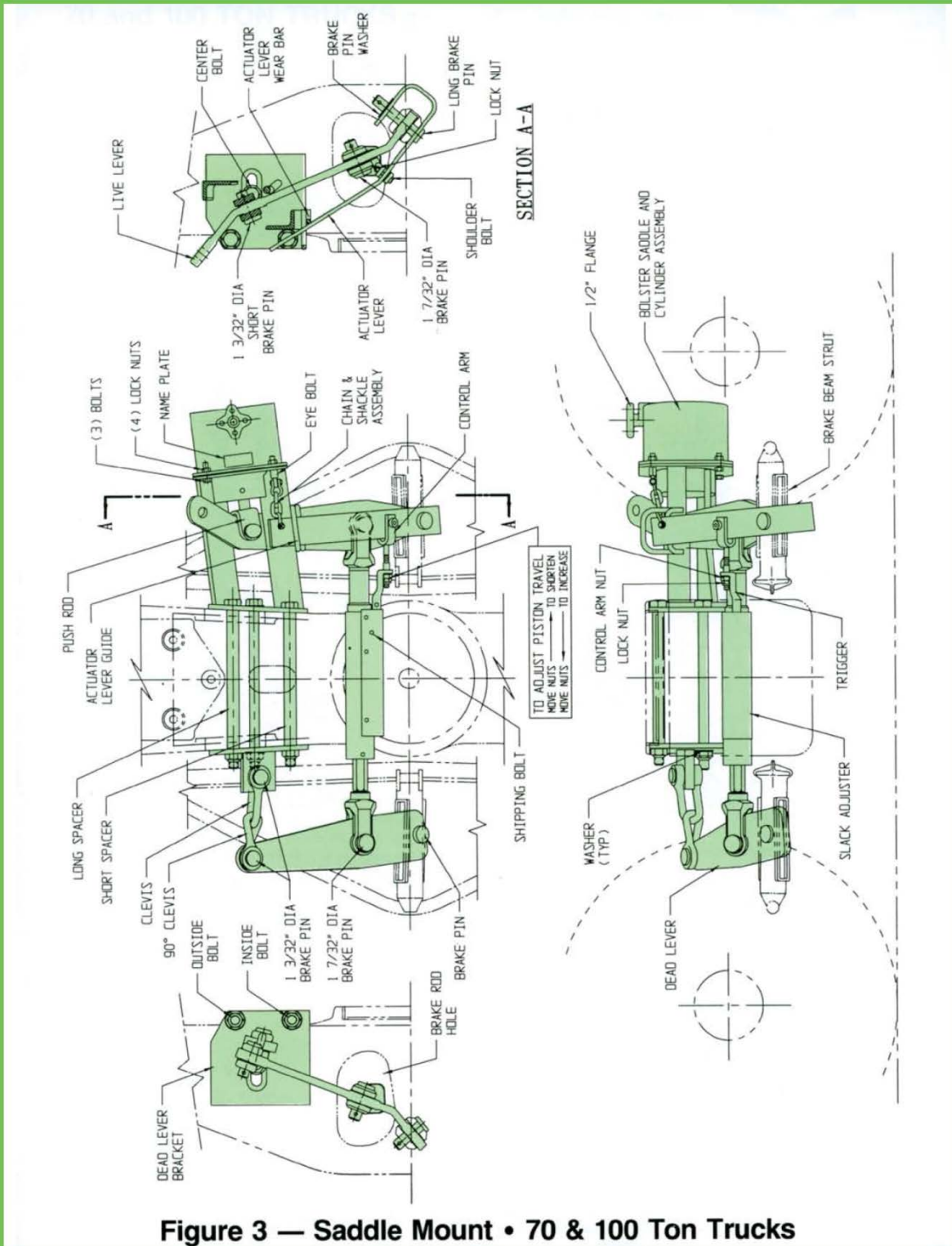

Figure 3 — Saddle Mount • 70 & 100 Ton Trucks

... with automatic double acting slack adjuster

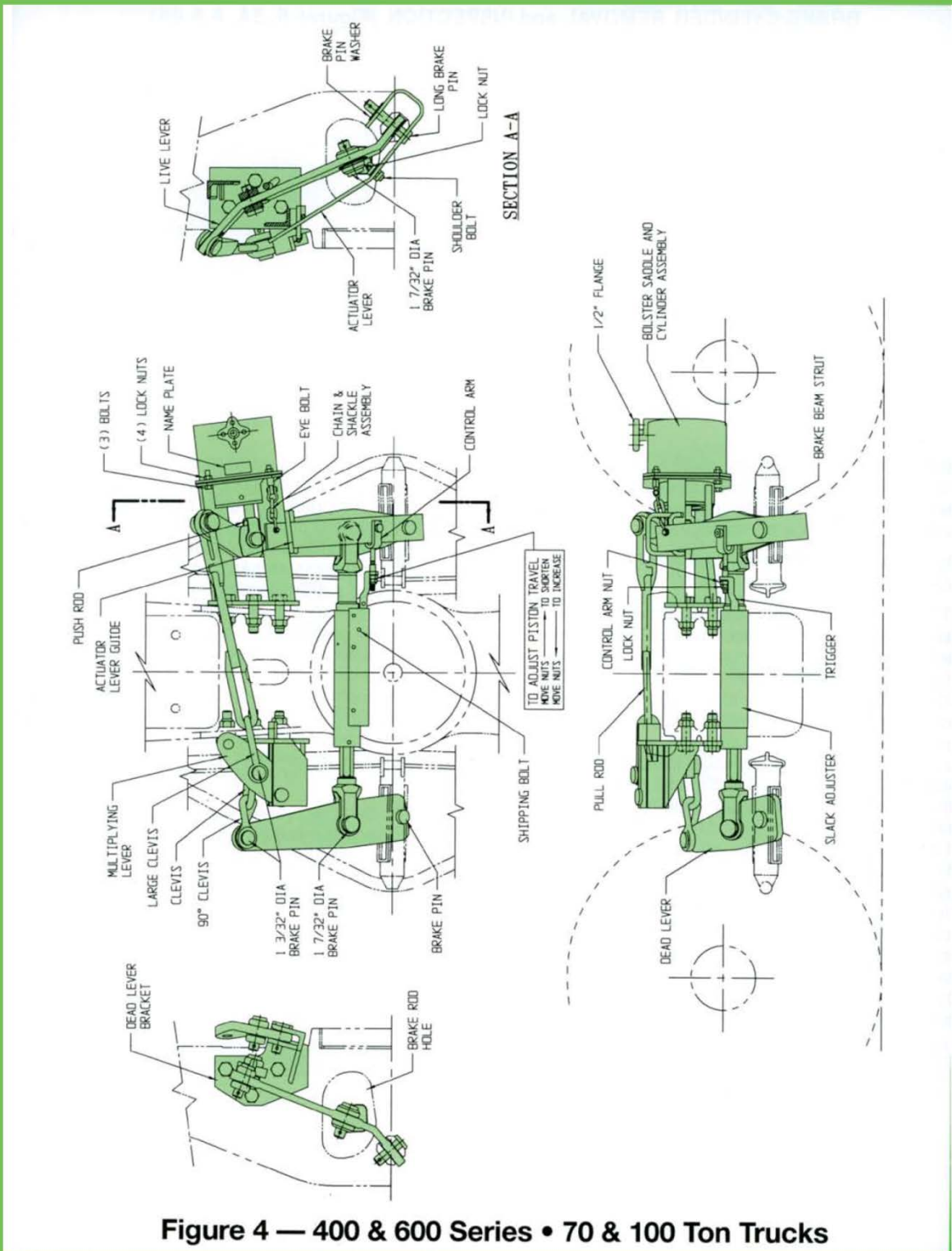
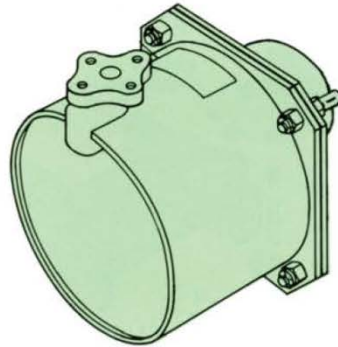
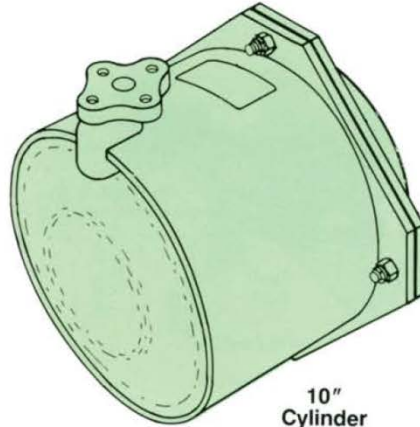

Figure 4 — 400 & 600 Series • 70 & 100 Ton Trucks

BRAKE CYLINDER REMOVAL and INSPECTION (Figures 5, 5A, 6 & 6A)



7-1/2" and 8-1/2" Cylinders



10" Cylinder

Before starting disassembly, make sure there is no air in the brake cylinder line by pulling the combined reservoir and brake cylinder release valve handle located on the service portion of the air brake.

It is recommended that the truck be rolled out from under the car.

To disassemble brake cylinders, disconnect hand brake hook up at truck mounted brake live lever where applicable. Then disconnect air hose connection at brake cylinder, lift car, and roll truck out from under the car. Remove the four bolts and lock nuts attaching the cylinder to the non-pressure head of the bolster saddle. As the bolts are loosened, the piston return spring will push the cylinder towards the axle. Rotate the cylinder upward and slide it over the axle. Pull the piston assembly, which includes the piston, wear ring and packing cup, and return spring, out of the cylinder. Remove and discard the felt retainer and felt lubricator (old style Figures 5A & 6A) or front seal assembly which consists of retainer, two small o-rings, felt lubricator, and large o-ring (new style figures 5 & 6) from the non-pressure head. It may be necessary to back off the oil fill bolt to remove the retainer. Check the new style retainer; discard if worn. Remove and discard the breather assembly. Disassembly is now complete.

Discard the packing cup, wear ring, flange gasket, breather assembly, and four lock nuts. The bolts can be reused if not damaged.

Inspect piston for cracks or other damage. Clean and check the cylinder bore for wear and scratches. Clean the non-pressure head cavity.

Lubricate the cylinder bore and non-pressure head cavity with A.A.R. approved lubrication. (All lubrication is to be A.A.R. approved). Apply a new breather assembly to the outside of the non-pressure head and install a new or reconditioned front seal assembly with o-ring into the non-pressure head cavity. Assemble the wear ring and packing cup on piston, lubricate flange of packing cup and assemble into cylinder making sure the packing cup is not deformed or pinched. Slip the spring over the piston sleeve. Insert four bolts (some units have an eye bolt attached to the chain and shackle assembly) through the non-pressure head flange, insert gasket onto bolts and work the cylinder assembly down over the axle and onto the four bolts. Apply four new lock nuts and tighten.

NOTE: Be sure cylinder air inlet is at the correct orientation.

Inspect air hose connected to the cylinder line. If frayed or kinked, apply new one. Retruck car, connect air hose to 1/2" cylinder air inlet, and reconnect hand brake hook up if applicable.

Perform required air test.



For more detailed drawings, technical data or service related questions, contact the Ellcon-National Engineering department.

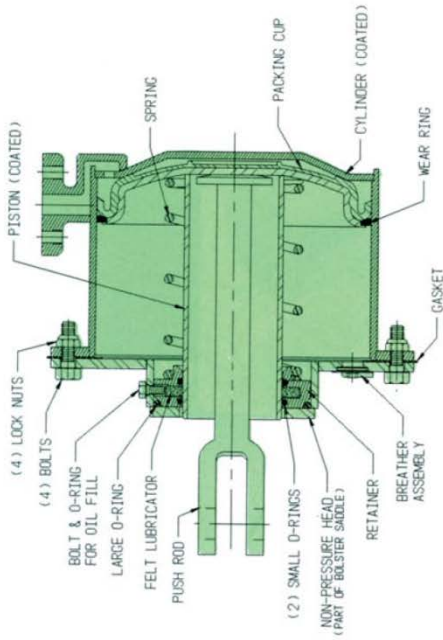

Figure 6 — New 10" Diameter Cylinder

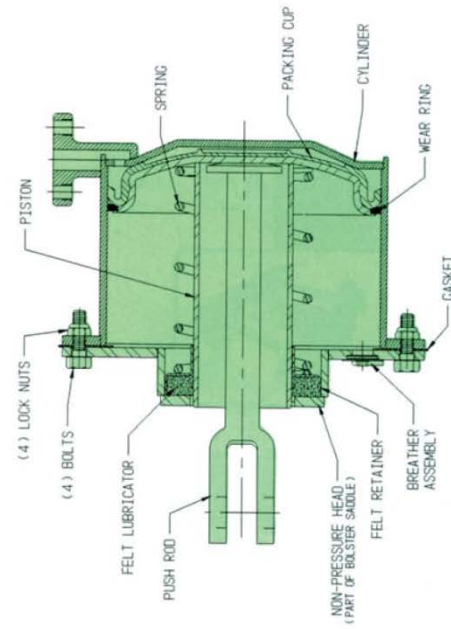

Figure 6A — Old 10" Diameter Cylinder

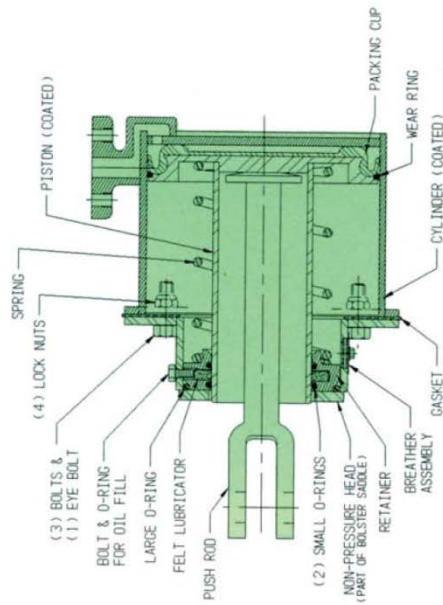

Figure 5 — New 7-1/2" & 8-1/2" Diameter Cylinder

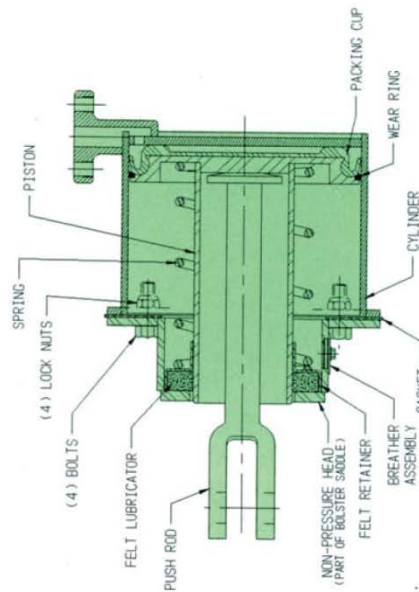
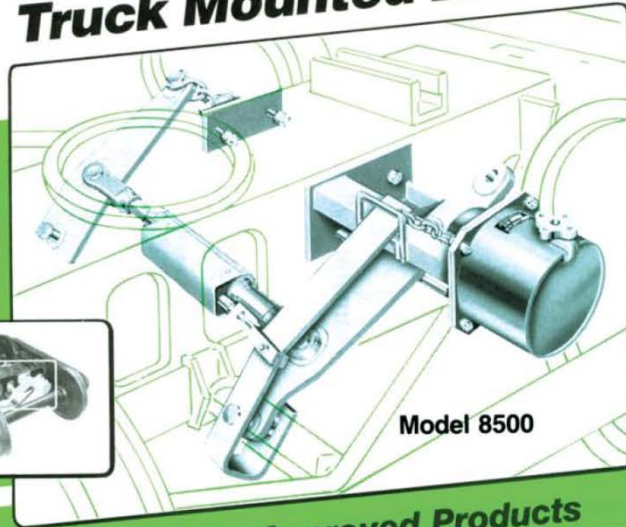

Figure 5A — Old 7-1/2" & 8-1/2" Diameter Cylinder

Truck Mounted Brakes

AAR
Approved



Model 8500

Other AAR Approved Products



Empty/Load Devices



Retaining
Valve



Hand Brakes



Slack
Adjusters



Ball Style
Straight Cocks



S.S. Ball Valves
for Tank Car Service



S.S. Ball Valves
Flange to Threaded



"Norson"
Pneumatic
Discharge Gates



ELLCON



NATIONAL

50 Beechtree Blvd., P.O. Box 9377 • Greenville, SC 29604-9377
Phone: 864-277-5000 • FAX: 864-277-5207

APPENDIX C: MAINTENANCE & REPAIR MANUAL FOR THE BRAKE COMPONENTS

C.1: Instruction Pamphlet Repair Track Maintenance of DB-60 Type Freight Brake Equipment, IP-175 Rev 07 08/8/2016 - en

Rail Vehicle Systems

IP-175

Rev 07 08/8/2016 - en

Instruction Pamphlet

Repair Track Maintenance of
DB-60 Type Freight Brake Equipment

NEW YORK AIR BRAKE 

Current version of IP-175 can be accessed at <https://nyabdelivery.com/documentLibrary?text=IP-175&docType=&docCategory=&docProductGroup=>



Repair Track Maintenance
 DB-60 Doc.-No.: IP-175
 Revision: 07 08/8/2016 - en

Contact Address

New York Air Brake Phone: +1 315 788 5200
 748 Starbuck Avenue Fax: +1 315 788 5678
 Watertown, NY 13601
 USA
www.nvab.com

Revision History

Rev	Date	Name	Para.	Description of Change
01	12/12/03			Original Issue
02	12/4/04		Chap. 5	Added, Section 4 through 10
03	6/18/07		Chap. 4 Chap. 5	Added Sections Updated figures 33 thru 35, added fig. 9
04	2/27/08			Added Section 5.11
05	8/8/10			Updated illustrations on pgs 47, 48, 51 and 52
06	9/18/13		Section 5.5	Added orientation note – renumbered section headings
07	8/8/16	L. Vaughn	All Section 5.12.11 Section 5.13.11	Reformatted to COPE Revised and added 5.12.11.4 Revised and added 5.13.11.4

Copyright 2016© New York Air Brake AG. All rights reserved, including industrial property rights applications.
 New York Air Brake AG retains any power of disposal, such as copying and transferring.





Repair Track Maintenance
 DB-60 Doc.-No.: IP-175
 Revision: 07_08/6/2016 - en

Table of Contents

1	General Information	5
1.1	Introduction	5
1.2	Technical Changes	5
1.3	Target group for this document	5
1.4	Referenced Documents	5
1.5	Danger, Warning, Caution, and Notice Messages	6
2	Safety Precautions	8
3	General Requirements	9
4	Procedure for Testing DB-60 Type Freight Brakes on Repair Tracks	10
5	Procedure for Cleaning, Disassembling and Assembling of DB-60 Type Freight Brakes on Repair Tracks	11
5.1	DB-10 Service Portion	11
5.2	DB-20 and DB-20L Emergency Portions	22
5.3	Body Mounted Cylinders	25
5.4	Truck Mounted Cylinders	28
5.5	Vent Valve	45
5.6	Angle Cock	47
5.7	End Cock	48
5.8	Dirt Collector Cut-Out Cock	49
5.9	Retaining Valve	51
5.10	KRD2A-500AR Slack Adjuster	53
5.11	KRD-482-E Slack Adjuster	57
5.12	EL-60 Empty Load Valve Portion	61
5.13	ELRP Sensor Valve	63
5.14	ELRP Load Proportional Valve	66
5.15	S-1 Load Sensor Valve	68
5.16	P-1 Load Proportional Valve	70
6	Rubber Parts, Shelf Life and Storage	72
7	Procedure for Cleaning DB-60 Type Freight Brakes That Have Been Submerged	72

Copyright 2016© New York Air Brake AG. All rights reserved, including industrial property rights applications.
 New York Air Brake AG retains any power of disposal, such as copying and transferring.

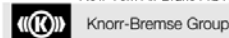



Repair Track Maintenance
 DB-60 Doc-No: IP-175
 Revision: 07_09/6/2016 - en

Table of Figures

Figure 1: DB-60 Control Valve Operating Portions and Standard Pipe Bracket14
 Figure 2: DB-60L Control Valve Operating Portions and Standard Pipe Bracket15
 Figure 3: DB-60 Control Valve Operating Portions and Single Sided Pipe Bracket16
 Figure 4: Shipping Parts.....17
 Figure 5: Control Valve Portions with Shipping Parts.....18
 Figure 6: Service Portion Strainer Nut Wrench19
 Figure 7: Strainer Nut for Standard Pipe Bracket without Access Receiver Plate20
 Figure 8: Strainer Nut for Standard Pipe Bracket with Access Receiver Plate20
 Figure 9: Choked Plug Stand-Off21
 Figure 10: Emergency Portion Strainer Nut Wrench23
 Figure 11: Instructions for DB-20 and DB-20L Emergency Portion Identification24
 Figure 12: Push Rod Connection26
 Figure 13: Non-Pressure Heads27
 Figure 14: Push Rod Holder and Locking Nuts30
 Figure 15: NYCOPAC Assembly with Handbrake31
 Figure 16: Spacing Block and Hanger Dimensions32
 Figure 17: Spacing Block Placement32
 Figure 18: NYCOPAC Hand Brake Adjustment34
 Figure 19: NYCOPAC II Assembly with Handbrake (Truck Set)37
 Figure 20: NYCOPAC IIA Assembly with Handbrake (Truck Set).....40
 Figure 21: TBM-60 Truck Mounted Brake System with Handbrake44
 Figure 22: KM-2 Vent Valve46
 Figure 23: No. 8 Vent Valve46
 Figure 24: Standard and Flanged Gripseal Angle Cocks47
 Figure 25: End Cock48
 Figure 26: Dirt Collector Cut-Out Cock50
 Figure 27: Composite Three Position Retaining Valve52
 Figure 28: NY-3 Three Position Retaining Valve52
 Figure 29: KRD2A-500AR Slack Adjuster54
 Figure 30: Center Rod Slack Adjuster Installation55
 Figure 31: Top Rod Slack Adjuster Installation56
 Figure 32: KRD-482-E Slack Adjuster58
 Figure 33: Center Rod Slack Adjuster Installation59
 Figure 34: Top Rod Slack Adjuster Installation60
 Figure 35: EL-60 Empty Load Valve Portion61
 Figure 36: ELRP Sensor Portion64
 Figure 37: ELRP Proportional Valve Portion67
 Figure 38: S-1 Sensor Valve68
 Figure 39: P-1 Load Proportional Valve71
 Figure 40: Port Identification Standard Pipe Bracket (Emergency Portion Face).....74
 Figure 41: Port Identification Standard Pipe Bracket (Service Portion Face)75
 Figure 42: Port Identification Single Sided Pipe Bracket (Portion Face)76
 Figure 43: Port Identification Single Sided Pipe Bracket (Pipe Face)77

Copyright 2016© New York Air Brake AG. All rights reserved, including industrial property rights applications.
 New York Air Brake AG retains any power of disposal, such as copying and transferring.

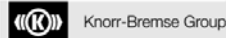

1 General Information

	<p>CAUTION</p> <p>Please read this document from start to finish to ensure safety of operation and to avoid personal injuries and damage to equipment.</p>
---	---

1.1 Introduction

This manual covers procedures for cleaning and testing KNORR Freight Brake Equipment Components on repair tracks.

1.2 Technical Changes

New York Air Brake reserves the right to change the equipment or this document at any time without giving special notice.

1.3 Target group for this document

This document is intended for use by trained locomotive operating personnel who

- have the skill, experience, safety awareness and professional ability:
 - to operate the locomotive
- have read and understood this document from start to finish, and
- are familiar with the safety codes and accident prevention regulations for these activities.

	<p>NOTE</p> <p>This document will be useful to other target groups as well, e.g. project engineers.</p> <p>However, it does not claim to provide complete information for such target groups.</p>
---	--

1.4 Referenced Documents

Doc. ID	Doc. No	Issue (Index, ..)	Title
•			

The original document was issued in English language.

Copyright 2016© New York Air Brake AG. All rights reserved, including industrial property rights applications.
 New York Air Brake AG retains any power of disposal, such as copying and transferring.



1.5 Danger, Warning, Caution, and Notice Messages

 These symbols indicate that important personal safety information follows. Carefully read and understand each safety related text message and apply the message to the operation and maintenance of the system as defined in the safety alert message.

The following are definitions associated with the different safety alert message categories.

The words DANGER, WARNING, and CAUTION are used to identify levels of hazard seriousness for the safety of the personnel and the equipment.

The word DANGER is used to signify an immediate hazard and is used throughout this manual in the following manner:

	DANGER Indicates an imminently hazardous situation, which if not avoided, will result in death or serious injury. This word is to be limited to the most extreme situations.
---	--

The word WARNING is used to signify hazards or unsafe practices and is used throughout this manual in the following manner:

	WARNING Failure to comply with these instructions may lead to irreversible physical injuries which may have fatal consequences.
---	---

The word CAUTION just like the word WARNING is used to signify hazards or unsafe practice in addition to equipment damage and is used throughout this manual in the following manner:

	CAUTION Failure to comply with these instructions may lead to personal injuries and/or to damage to the unit or the environment.
---	--

The NOTE (NOTICE) messages are used throughout this manual in the following manner:

	NOTE Notes do not contain any messages relevant to safety. Notes contain useful hints and additional information used to highlight suggestions which will result in enhanced installation, reliability, or operation.
---	--

Safety messages/notes have a specific structure which is explained here for DANGER (This also applies to WARNINGS and CAUTIONS):



Repair Track Maintenance
DB-60 Doc-No: IP-175
Revision: 07 09/6/2016 - en

DANGER	DANGER Source of the danger Consequences of the danger Remedial measures
---------------	--

Notes do not contain any messages relevant to safety and are included only for the sake of completeness.

NOTICE	NOTE Notes contain useful hints and additional information about the unit.
---------------	--

Copyright 2016© New York Air Brake AG. All rights reserved, including industrial property rights applications.
New York Air Brake AG retains any power of disposal, such as copying and transferring.

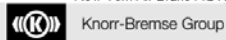

Page 7 / 77



2 Safety Precautions

- 2.1 Observe all Railroad rules and regulations. Whenever there is a conflict between the instructions given in this manual, the Railroads rules and regulations will govern.
- 2.2 When performing any test work on devices or equipment while they are on the vehicle (Single car test, etc.) special precautions must be taken to ensure that vehicle movement will not occur which could result in injury to personnel and/or damage to equipment. Make sure the hand brake is applied and that the wheels are chocked to prevent vehicle from moving.
- 2.3 De-pressurize air system before loosening connections or components. Before removing any component from its mountings, the car must be safely parked. To prevent personal injury, all brake supply reservoir and brake cylinder air on the car must be vented.
- 2.4 "Bottled" up air under pressure (even though air supply is cut off) may cause gaskets and/or particles of dirt to become airborne and an increase in sound level when any component part is removed from the equipment arrangement. Personal eye and ear protection must be worn and care taken to avoid possible injury when performing any work on these component parts.
- 2.5 The use of an air jet, which must be less than 30 PSIG, to blow parts clean or to blow them dry after being cleaned with a solvent will cause particles of dirt and/or droplets of the cleaning solvent to be airborne. These particles and droplets may cause skin and /or eye irritation. Personal eye protection must be worn to protect the eyes from possible injury. When using an air jet do not direct it toward another person. Improper use of air jet could result in bodily injury.
- 2.6 If degreasing fluids are used for cleaning purposes, the current local safety regulations plus the safety precautionary statements of the manufacturer of the cleaning agent must be adhered to. Otherwise, physical harm could result from the inhalation of toxic fumes. Make sure the area is well ventilated when working with materials that produce harmful fumes.
- 2.7 Personal eye protection must be worn when doing any work to protect eyes from possible injury.
- 2.8 When performing maintenance procedures on system components, assemblies may be under a spring load. Exercise caution during disassembly so that no parts "Fly Out" and cause bodily injury.
- 2.9 Where fasteners removed from the car equipment are not satisfactory for reuse, care must be taken to select replacements that match the originals. Mismatched or incorrect fasteners can result in equipment damage or malfunction, or possible personal injury.
- 2.10 Follow all WARNING, CAUTIONS, and NOTES found throughout this Pamphlet. If you must use a work procedure or tool which is not recommended, you must first satisfy yourself that neither your safety, your fellow workers safety, nor that of the equipment will be jeopardized by the method selected.
- 2.11 Appropriate tool selection is required when performing all maintenance operations to avoid personal injury.
- 2.12 Person(s) having the appropriate job skill level as governed by the Railroad are required when performing maintenance and/or operational tasks with the brake system and system components.

Copyright 2016© New York Air Brake AG. All rights reserved, including industrial property rights applications.
New York Air Brake AG retains any power of disposal, such as copying and transferring.





Repair Track Maintenance
DB-60 Doc.-No.: IP-175
Revision: 07 08/6/2016 - en

3 General Requirements

- 3.1 Repair locations must be provided with: a grease can so arranged that both the grease and brush can be protected against dirt, one extra set of shipping covers for the service and emergency portions of the DB-60 and DB-60L Control Valves, a release valve stem guard for the service portion (See Fig. 4), an air hose, and suitable tools such as wrenches, scrapers, clamps, etc.
- 3.2 AAR Specifications for lubricants referred to in this manual are M-914 brake cylinder lubricant, M-913 dry graphite and M-912 triple valve oil.
- 3.3 The lubricant container must be stenciled with the proper AAR specification identification.
- 3.4 Record the car number, owner, and last cleaning date if required for billing purposes.
- 3.5 All old cleaning marks must be scraped off and painted over with quick drying paint, preferably black.
- 3.6 All dismantling, parts removal, replacement of portions, cleaning and re-lubricating of assemblies or parts thereof, must be done by a qualified person at a suitable bench in a clean, well-lighted location in an AAR approved air brake shop.
- 3.7 Inspect angle/end cocks and dirt collector cut-out cocks for external damage, including worn, broken, or missing/handle stops/lugs. Defective angle/end cocks and dirt collector cut-out cocks must be renewed with ball-type.

Copyright 2016© New York Air Brake AG. All rights reserved, including industrial property rights applications.
New York Air Brake AG retains any power of disposal, such as copying and transferring.



Page 9 / 77



Repair Track Maintenance
DB-60 Doc-No: IP-175
Revision: 07 08/6/2016 - en

4 Procedure for Testing DB-60 Type Freight Brakes on Repair Tracks

- 4.1 Repair Track and Single Car Testing of air brakes must be performed at 90 psi.
- 4.2 All air brake testing must be performed in accordance with the applicable sections of AAR Standard S-486, latest revision.
- 4.3 If the DB-10 Service Portion is determined to be defective, refer to Section 5.1.
- 4.4 If the DB-20 Emergency Portion is determined to be defective, refer to Section 5.2.
- 4.5 If a Body Mounted Brake Cylinder is determined to be defective, refer to Section 5.3.
- 4.6 If a Truck Mounted Brake Cylinder is determined to be defective, refer to Section 5.4.
- 4.7 If the Vent Valve is determined to be defective, refer to Section 5.5.
- 4.8 If the Angle Cock is determined to be defective, refer to Section 5.6.
- 4.9 If the End Cock is determined to be defective, refer to Section 5.7.
- 4.10 If the Dirt Collector Cut-Out Cock is determined to be defective, refer to Section 5.8.
- 4.11 If the Retaining Valve is determined to be defective, refer to Section 5.9.
- 4.12 If the Slack Adjuster is determined to be defective, refer to Section 5.10 – 5.11.
- 4.13 If the Empty Load Portion is determined to be defective, refer to Section 5.12 – 5.16.
- 4.14 Repairs, when required, must be made in accordance with the components specific maintenance procedures, which can be obtained from a NYAB service representative.

Copyright 2016© New York Air Brake AG. All rights reserved, including industrial property rights applications.
New York Air Brake AG retains any power of disposal, such as copying and transferring.

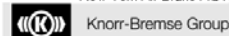

Page 10 / 77



5 Procedure for Cleaning, Disassembling and Assembling of DB-60 Type Freight Brakes on Repair Tracks

 **WARNING**

WARNING
Cleaning using compressed air can cause particles to become airborne, be sure to:

- Wear eye protection
- Do not exceed 30 PSI

Failure to comply with these instructions may lead to irreversible physical injuries which may have fatal consequences

 **WARNING**

WARNING
Solvents and solvent fumes can be harmful to health, when using solvents be sure to:

- Wear eye, skin, and respiratory protection
- Work in a well-ventilated area
- Avoid repeated or prolonged contact
- Keep solvent container closed
- Keep solvent away from sparks, flames, and heat

Failure to comply with these instructions may lead to injury or intoxication.

5.1 DB-10 SERVICE PORTION

If the results of the air brake testing confirm that the service portion is defective, the following steps are used to replace the service portion.

- 5.1.1 A strainer nut wrench (See Fig. 6) and Standard box end wrenches or socket wrenches with wrench openings of 15/16" and pliers to remove cotter pin from release valve handle are necessary.
- 5.1.2 Drain the air out of the auxiliary reservoir, emergency reservoir and brake cylinder.
- 5.1.3 Disconnect the release valve handle, leaving it attached to the release rod.
- 5.1.4 Scrape, wipe and blow off all dirt adjacent to the gasket between the pipe bracket and the valve portion. Use air hose to blow off all loose dirt on the control valve portion, pipe bracket, hopper slopes, car under frames, etc., that may otherwise get into the control valve portion or bracket when the portion is being removed and a cleaned portion is being applied.

Copyright 2016© New York Air Brake AG. All rights reserved, including industrial property rights applications.
New York Air Brake AG retains any power of disposal, such as copying and transferring.

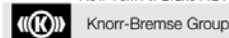



- 5.1.5 Remove the service portion and immediately apply the spare shipping cover and gasket to the portion (See Fig. 4 and 5) and tighten the mounting nuts.
- 5.1.6 The service portion must be carefully handled to avoid entrance of dirt, water or damage to internal parts.
- 5.1.7 Apply standard or alternate stem guard to the service portion (See Fig. 4 and 5) and hold in place with cotter pin.
- 5.1.8 When the valve portion is removed and conditions are found in the portion or the pipe bracket evidencing that the car brake equipment has been submerged in water, special additional cleaning operations not regularly performed, will be required as directed in Section 7.0.
- 5.1.9 For portions mounted on a standard pipe bracket, see figure 1 & 2, a filter element is located in the pipe bracket behind the service portion. Remove the filter element using strainer nut wrench (See Fig. 6).
- 5.1.10 Blow any dirt or water out of the yard airline and connect it to car brake pipe.
- 5.1.11 Close the dirt collector cutout cock. Blow out the brake pipe by opening the angle cock at the opposite end of car, then apply a dummy coupling to this end and leave both angle cocks open.
- 5.1.12 Remove the cup from the dirt collector and leave it off until cleaned valve portion is applied. Open the dirt collector cut-out cock to blow dirt from the branch pipe, then close it.
- 5.1.13 For portions mounted on a standard pipe bracket, see figure 1 & 2, apply a new filter element, located in the pipe bracket behind the service portion. A wood mandrel will assist in guiding the filter into proper position. Make certain its inner end is in engagement with the sealing bead (if inserted properly, all nut threads in the bracket will be visible), then install strainer nut shown in figure 7 if the pipe bracket **does not** have an access receiver plate or strainer nut shown in figure 8 if the pipe bracket **does** have an access receiver plate and tighten it firmly with the service portion strainer nut wrench (See Fig. 6).
- 5.1.14 The pipe bracket gasket must be replaced with a new gasket. On single sided pipe brackets with an access receiver plate, see figure 9, a choked plug stand-off is installed in the pipe bracket gasket and must be re-installed on the new gasket.
- 5.1.15 The shipping cover must not be removed from the clean service portion until prepared to immediately mount the portion on the pipe bracket.
- 5.1.16 Remove the shipping cover from the clean service portion and immediately apply the portion to the pipe bracket and, after coating the threads lightly with brake cylinder lubricant (AAR Spec. M-914) or a compound consisting of one part dry graphite (AAR Spec. M-913) and two parts of oil (SAE-20) by weight, tighten the mounting nuts evenly and firmly to 65 to 75 ft. lb. of torque.
- 5.1.17 When replacing valve portion it is important that mounting nuts are sufficiently tightened to prevent gasket leakage and yet not excessively to cause distortion of covers and gaskets.
- 5.1.18 Remove the stem guard.

Copyright 2016© New York Air Brake AG. All rights reserved, including industrial property rights applications.
New York Air Brake AG retains any power of disposal, such as copying and transferring.





NEW YORK AIR BRAKE

Repair Track Maintenance

DB-60

Doc.-No.: IP-175

Revision: 07_09/6/2016 - en

- 5.1.19 Reconnect the release valve handle, which had been left attached to release rod, to release valve handle end plate with a 3/16" cotter. Note that a 5/16" cotter is provided to connect rod to handle, if not, replace with a 5/16" cotter.
- 5.1.20 Clean and blow out the dirt collector dirt chamber. Clean the check valve. Refer to GL-465 and replace check valve if required. Renew the gasket, and then assemble and tighten the bolts evenly to 29 to 35 ft. lb. dry torque.
- 5.1.21 Check the cylinder, reservoir and pipe bracket for loose mounting bolts and nuts and if missing or loose, they must be renewed or tightened. See 7.9 for Torque requirements.
- 5.1.22 After all repairs have been completed, the entire air brake equipment must be tested Per rule 3 of the AAR Field Manual.
- 5.1.23 For reconditioning the DB-10 Service Portion, refer to New York Air Brake Repair Procedure NYR-332 latest revision. Copies may be obtained through any Field Office.

Copyright 2016© New York Air Brake AG. All rights reserved, including industrial property rights applications.
New York Air Brake AG retains any power of disposal, such as copying and transferring.



Knorr-Bremse Group

Page 13 / 77



Repair Track Maintenance
 DB-60 Doc.-No.: IP-175
 Revision: 07 08/8/2016 - en

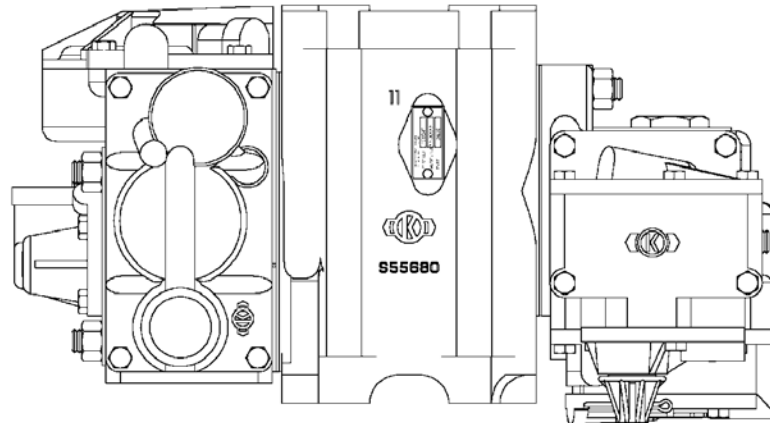

DB-20
Emergency Portion

DB-30
Pipe Bracket

DB-10
Service Portion

Front View

778105ASSY1

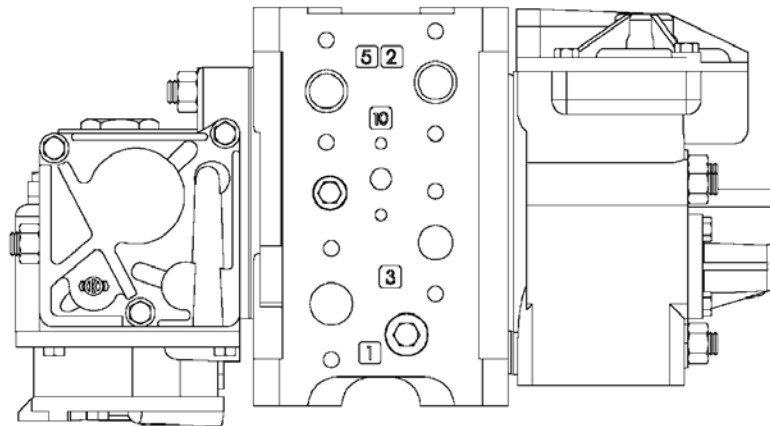

DB-10
Service Portion

DB-30
Pipe Bracket

DB-20
Emergency Portion

Rear View

776105ASSY2

Figure 1: DB-60 Control Valve Operating Portions and Standard Pipe Bracket

Copyright 2016© New York Air Brake AG. All rights reserved, including industrial property rights applications.
 New York Air Brake AG retains any power of disposal, such as copying and transferring.

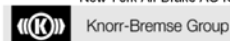



Repair Track Maintenance
 DB-60 Doc.-No.: IP-175
 Revision: 07 08/8/2016 - en

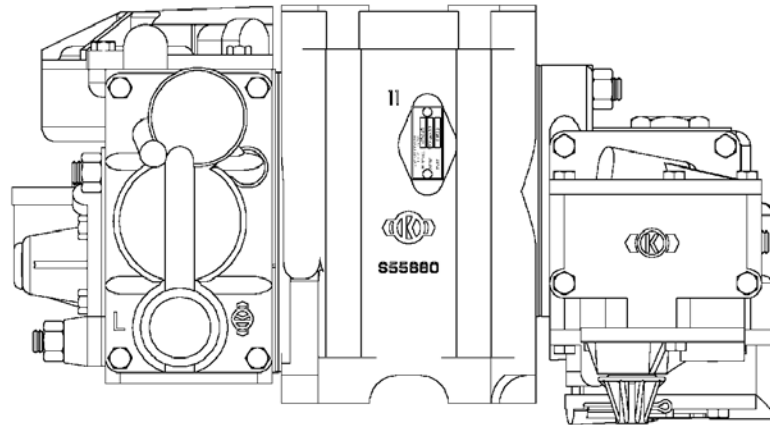

DB-20L
Emergency Portion

DB-30L
Pipe Bracket

DB-10
Service Portion

Front View

778106ASSY1

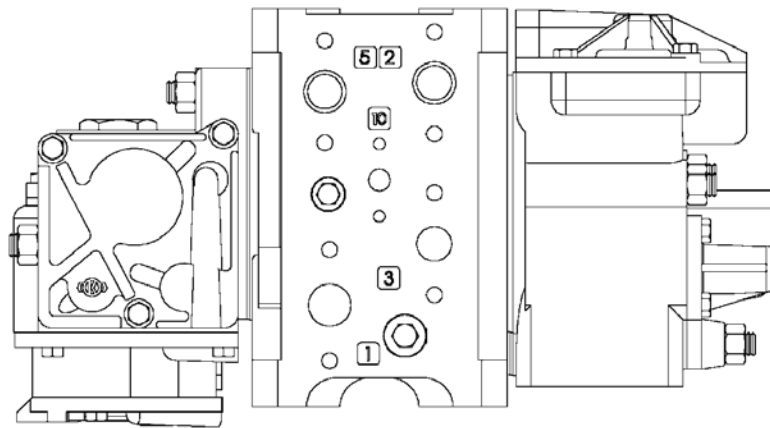

DB-10
Service Portion

DB-30L
Pipe Bracket

DB-20L
Emergency Portion

Rear View

778106ASSY2

Figure 2: DB-60L Control Valve Operating Portions and Standard Pipe Bracket

Copyright 2016© New York Air Brake AG. All rights reserved, including industrial property rights applications.
 New York Air Brake AG retains any power of disposal, such as copying and transferring.

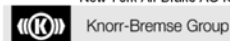



Repair Track Maintenance
 DB-60 Doc.-No.: IP-175
 Revision: 07 08/8/2016 - en

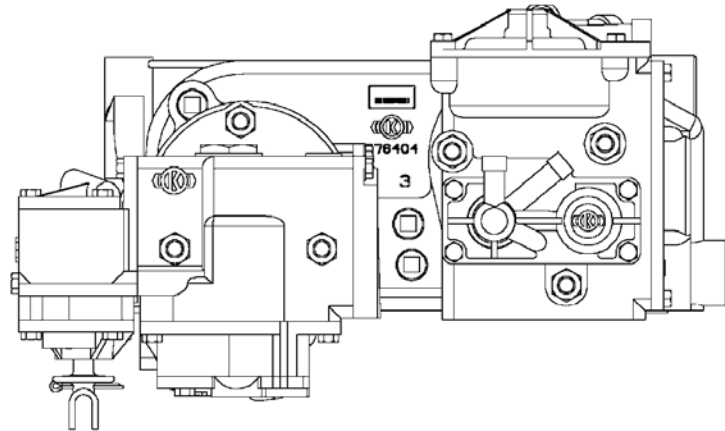

DB-10
 Service Portion

DB-30S
 Single Sided
 Pipe Bracket

DB-20
 Emergency Portion

Front View

773818ASSY1

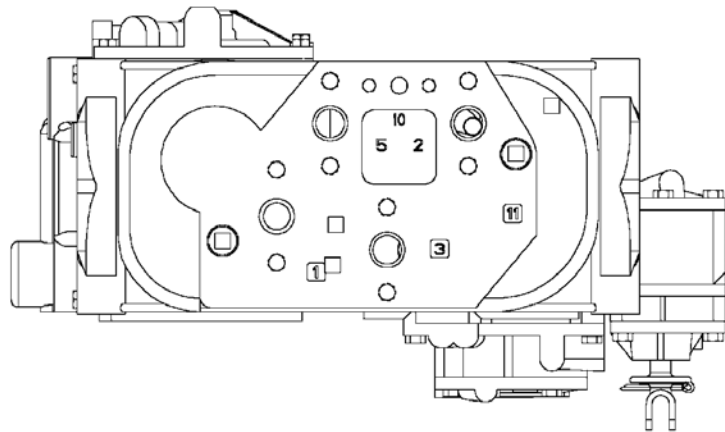

DB-20
 Emergency Portion

DB-30S
 Single Sided
 Pipe Bracket

DB-10
 Service Portion

Rear View

773818ASSY2

Figure 3: DB-60 Control Valve Operating Portions and Single Sided Pipe Bracket

Copyright 2016© New York Air Brake AG. All rights reserved, including industrial property rights applications.
 New York Air Brake AG retains any power of disposal, such as copying and transferring.

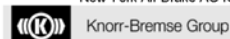



Repair Track Maintenance
DB-60 Doc.-No.: IP-175
Revision: 07 08/8/2016 - en

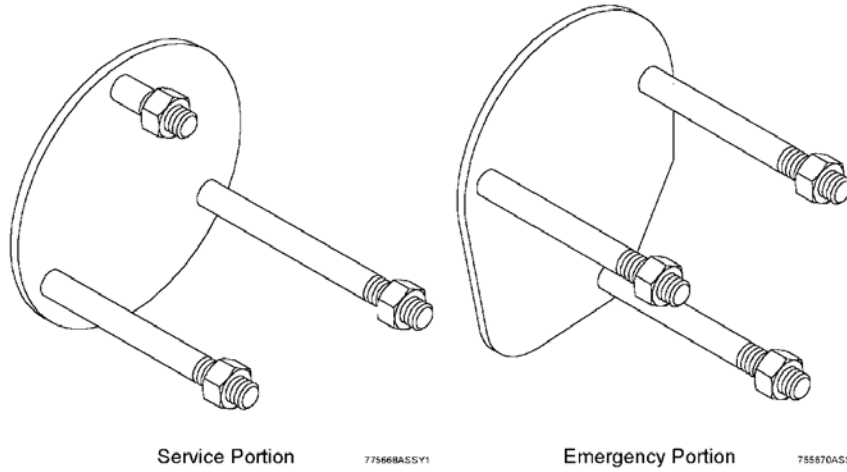

SHIPPING COVERS

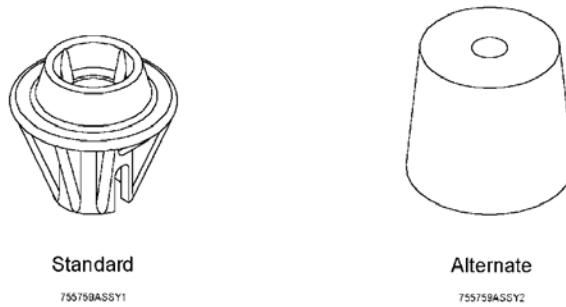

RELEASE VALVE STEM GUARDS

Figure 4: Shipping Parts

Copyright 2016© New York Air Brake AG. All rights reserved, including industrial property rights applications.
New York Air Brake AG retains any power of disposal, such as copying and transferring.

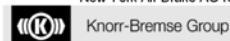



Repair Track Maintenance
DB-60 Doc.-No.: IP-175
Revision: 07 08/8/2016 - en

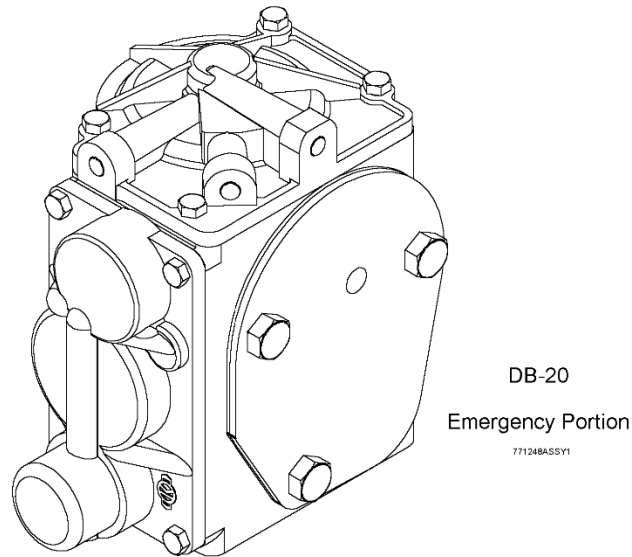
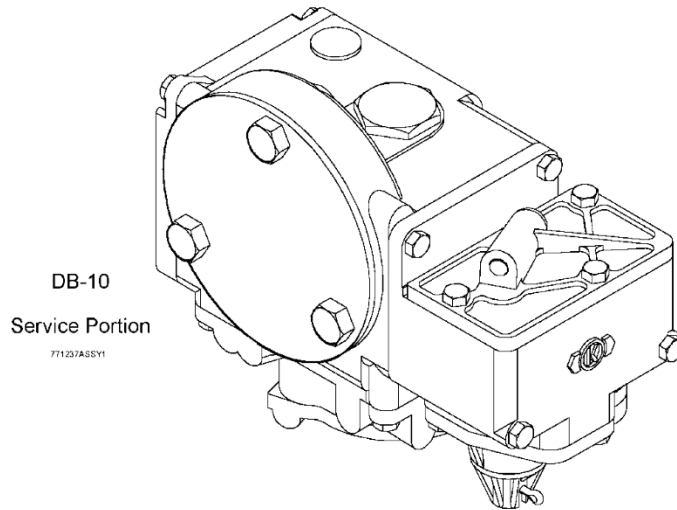

Figure 5: Control Valve Portions with Shipping Parts

Copyright 2016© New York Air Brake AG. All rights reserved, including industrial property rights applications.
New York Air Brake AG retains any power of disposal, such as copying and transferring.



Knorr-Bremse Group

Page 18 / 77



Repair Track Maintenance
DB-60 Doc.-No.: IP-175
Revision: 07 08/8/2016 - en

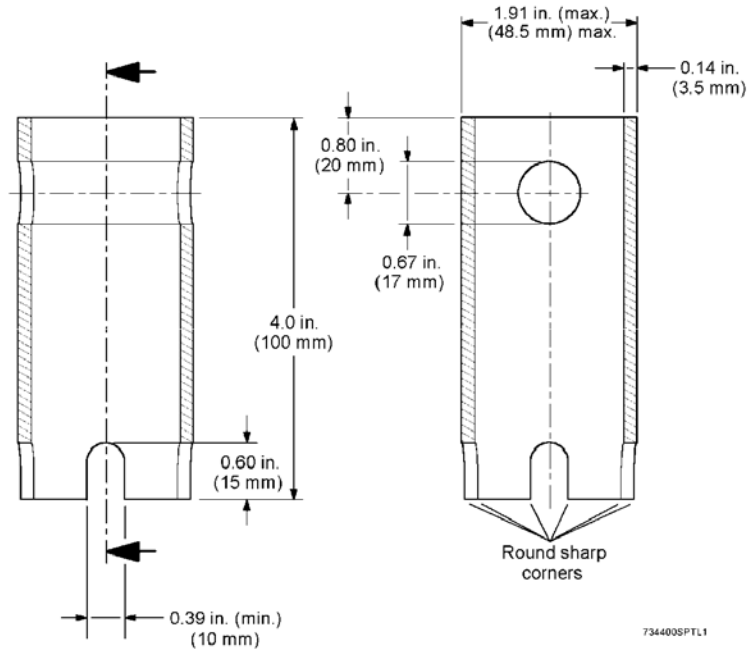
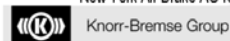

Figure 6: Service Portion Strainer Nut Wrench

Copyright 2016© New York Air Brake AG. All rights reserved, including industrial property rights applications.
New York Air Brake AG retains any power of disposal, such as copying and transferring.





Repair Track Maintenance
DB-60 Doc.-No.: IP-175
Revision: 07 08/8/2016 - en

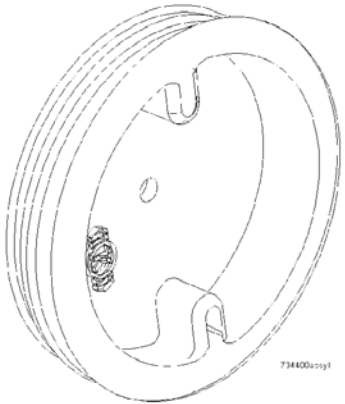

Figure 7: Strainer Nut for Standard Pipe Bracket without Access Receiver Plate

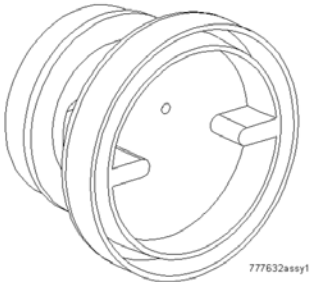
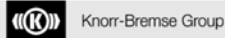

Figure 8: Strainer Nut for Standard Pipe Bracket with Access Receiver Plate

Copyright 2016© New York Air Brake AG. All rights reserved, including industrial property rights applications.
New York Air Brake AG retains any power of disposal, such as copying and transferring.





Repair Track Maintenance
DB-60 Doc.-No.: IP-175
Revision: 07 08/8/2016 - en

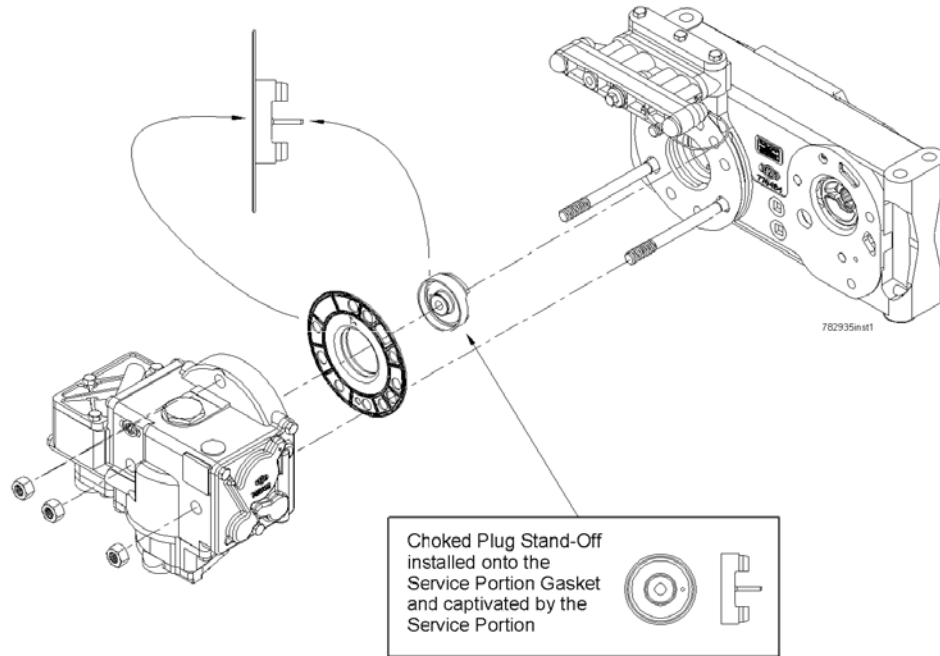
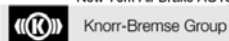

Figure 9: Choked Plug Stand-Off

Copyright 2016©New York Air Brake AG. All rights reserved, including industrial property rights applications.
New York Air Brake AG retains any power of disposal, such as copying and transferring.





5.2 DB-20 & DB-20L EMERGENCY PORTIONS

If the results of the air brake testing confirm that the emergency portion is defective, the following steps are used to replace the emergency portion.

- 5.2.1 A strainer nut wrench (See Fig. 6) and Standard box end wrenches or socket wrenches with wrench openings of 15/16" are necessary.
- 5.2.2 Drain the air out of the auxiliary reservoir, emergency reservoir and brake cylinder.
- 5.2.3 Scrape, wipe and blow off all dirt adjacent to the gasket between the pipe bracket and the valve portion. Use air hose to blow off all loose dirt on the control valve portion, pipe bracket, hopper slopes, car underframes, etc., that may otherwise get into the control valve portion or bracket when the portion is being removed and a cleaned portion is being applied.
- 5.2.4 Remove the emergency portion and immediately apply to it the spare shipping cover and gasket (See Fig. 4 and 5) and tighten its mounting nuts.
- 5.2.5 The emergency portion must be carefully handled to avoid entrance of dirt, water or damage to internal parts.
- 5.2.6 When the valve portion is removed and conditions are found in the portion or the pipe bracket evidencing that the car brake equipment has been submerged in water, special additional cleaning operations not regularly performed will be required as directed in Section 7.0.
- 5.2.7 Single sided pipe brackets contain a filter that is located in the pipe bracket, behind the Emergency portion. Remove the filter element using strainer nut wrench (See Fig. 6).
- 5.2.8 Blow any dirt or water out of the yard air line and attach hose connection to car brake pipe.
- 5.2.9 Close the dirt collector cutout cock. Blow out the brake pipe by opening the angle cock at the opposite end of car, then apply a dummy coupling to this end and leave both angle cocks open.
- 5.2.10 Remove the cup from the dirt collector and leave it off until cleaned valve portion is applied. Open the dirt collector cutout cock to blow dirt from the branch pipe, then close it.
- 5.2.11 For portions mounted on a single sided pipe bracket, install a new filter element into the pipe bracket located behind the emergency portion. A wooden mandrel will assist in guiding the filter into proper position. Make certain that the mandrel's inner end is engaged with the sealing bead (if inserted properly, all of the threads will be visible). Install the strainer nut and tighten it firmly using emergency portion strainer nut wrench (See Fig. 10).
- 5.2.12 Pipe bracket gasket must be replaced with a new gasket.
- 5.2.13 The shipping cover must not be removed from the clean emergency portion until prepared to immediately mount the portion on the pipe bracket.

Copyright 2016© New York Air Brake AG. All rights reserved, including industrial property rights applications.
New York Air Brake AG retains any power of disposal, such as copying and transferring.





NEW YORK AIR BRAKE

Repair Track Maintenance
 DB-60 Doc.-No.: IP-175
 Revision: 07 08/8/2016 - en

- 5.2.14 Dependent on the car length, an appropriate type of emergency portion, DB-20 or DB-20L, (identification see Fig. 11) must be available. A different lower stud on the pipe bracket ensures the appropriate portion. If in doubt of proper valve configuration consult Rule #4 of the AAR Field Manual of Interchanged Rules.
- 5.2.15 With the emergency portion gasket in place on the pipe bracket and fully seated at its locking projection, remove the shipping cover from the clean emergency portion. Immediately mount the portion, sliding it slowly and carefully on the studs against the pipe bracket. Tighten the mounting nuts evenly and firmly to 65 to 75 ft. lb. dry torque.

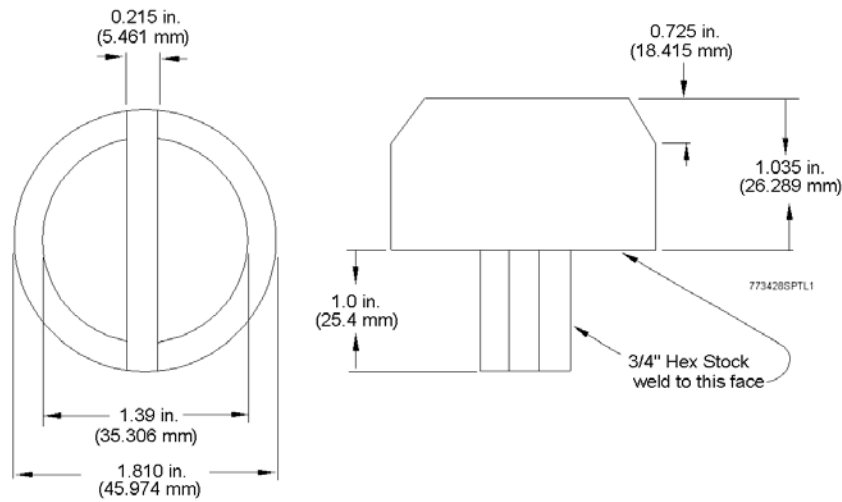

Figure 10: Emergency Portion Strainer Nut Wrench

- 5.2.16 When replacing a valve portion it is important that mounting nuts are sufficiently tightened to prevent gasket leakage and yet not excessively to cause distortion of covers and gaskets.
- 5.2.17 Clean and blow out the dirt collector dirt chamber. Clean the check valve. Refer to GL-465 and replace check valve if required. Renew the gasket, and then assemble, tightening the bolts evenly to 29 to 35 ft. lb. dry torque.
- 5.2.18 Check the cylinder, reservoir and pipe bracket for loose mounting bolts and nuts and if missing or loose, they must be renewed or tightened. See 7.9 for Torque requirements.
- 5.2.19 After all repairs have been completed, the entire air brake equipment must be tested Per Rule 3 of the AAR Field Manual.
- 5.2.20 For reconditioning the DB-20 or DB-20L Emergency Portions, refer to New York Air Brake Repair Procedure NYR-429 latest revision. Copies may be obtained through any Field Office.

Copyright 2016© New York Air Brake AG. All rights reserved, including industrial property rights applications.
 New York Air Brake AG retains any power of disposal, such as copying and transferring.



Knorr-Bremse Group

Page 23 | 77



Repair Track Maintenance
DB-60 Doc.-No.: IP-175
Revision: 07 08/8/2016 - en

The numeral '1' identifies all
Emergency Portions without
a Spill Over Check Valve.

The letter 'N' on the top cover
has no significance.

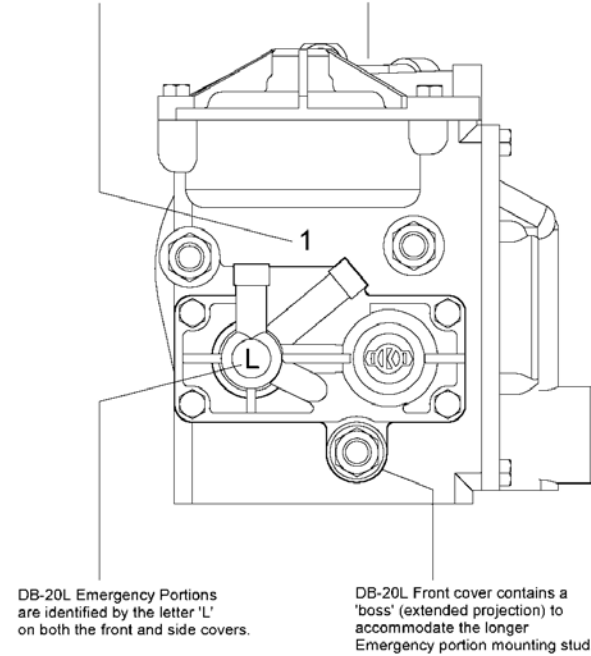

DB-20L Emergency Portions
are identified by the letter 'L'
on both the front and side covers.

DB-20L Front cover contains a
'boss' (extended projection) to
accommodate the longer
Emergency portion mounting stud.

788143LOC1

Figure 11: Instructions for DB-20 and DB-20L Emergency Portion Identification

Copyright 2016© New York Air Brake AG. All rights reserved, including industrial property rights applications.
New York Air Brake AG retains any power of disposal, such as copying and transferring.

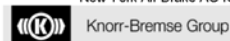



5.3 BODY MOUNTED CYLINDERS

If the results of the air brake testing confirm that the brake cylinder is defective, the following steps are used to replace the piston and non-pressure head assembly.

- 5.3.1 Drain air from all reservoirs and brake cylinders. Remove cotter pin and clevis pin. Disconnect and remove the brake cylinder push rod from the cylinder (See Fig. 12).

 WARNING	WARNING To avoid personal injury, which may occur is the Non-Pressure Head Assembly is not secured by the hollow rod collar, examine the collar to determine that it will hold securely.
--	--

- 5.3.2 Remove the piston, release spring, and non-pressure head as a complete assembly. These parts must be transported to an AAR approved air brake shop for reconditioning.
- 5.3.3 Suitable covers or containers must be provided. The brake cylinder piston, hollow rod and non-pressure head assemblies must be carefully handled at the car and while being transported to and from the car, so that all parts will be adequately protected against damage and contact with any kind of dirt.

NOTICE	NOTE It is the responsibility of individual railroads to provide adequate protective means for transporting components.
---------------	---

- 5.3.4 Remove the non-pressure head gasket, and clean its seat when cleaning the brake cylinder and apply a new gasket when assembling cylinder.
- 5.3.5 Thoroughly clean the brake cylinder by first using a dull rounded scraper for removal of all grease and any dirt.
- 5.3.6 Use a suitable solvent, if necessary, to soften gummy deposits and remove rust spots, then wipe dry and clean with rags.
- 5.3.7 When the cylinder is cleaned, unless prepared to immediately apply a cleaned and lubricated piston and non-pressure head assembly, the cylinder should be covered to protect it from dust and dirt.
- 5.3.8 The lubricant should be applied to the cylinder just before the cleaned and lubricated piston assembly is installed.
- 5.3.9 Fill the groove on the cylinder wall-bearing surface of the piston packing cup completely with brake cylinder lubricant (AAR Spec. M-914).





NOTE

On newer Brake Cylinders, the strainer is designed into the gasket and the non-pressure head has a matching indentation on its mounting face to accommodate the strainer. The older style uses a flat gasket with a separate strainer mounted in the exhaust opening on the side at the non-pressure head.

NOTICE

The combined gasket-strainer must only be used with the new design non-pressure head that has the matching indentation in the mounting face. (See Figure 13)

The flat gasket and separate round strainer must only be used on the older design non-pressure head with the exhaust opening on the side. (See Figure 13)

- 5.3.10 Immediately apply the new gasket and non-pressure head assembly to the cylinder making sure that the non-pressure head exhaust and strainer is located in the down position, then tighten the non-pressure head bolts to 30 +/- 3 ft-lbs dry torque.
- 5.3.11 Connect the push rod to clevis and lever using clevis pin and cotter pin. (See Fig. 12)
- 5.3.12 Slack adjusters on cars so equipped must be inspected and repaired or renewed when necessary.
- 5.3.13 If the pipe flange has been disconnected from the cylinder, replace the ring gasket and tighten the 1/2" grade 5 flange bolts to 55 +/- 5 ft-lbs dry torque.
- 5.3.14 After all repairs have been completed, the brake cylinder must be tested per Rule 3 of the AAR Field Manual.
- 5.3.15 For reconditioning Body Mounted Cylinders, refer to New York Air Brake Repair Procedure NYR-428 latest revision. Copies may be obtained through any field office.

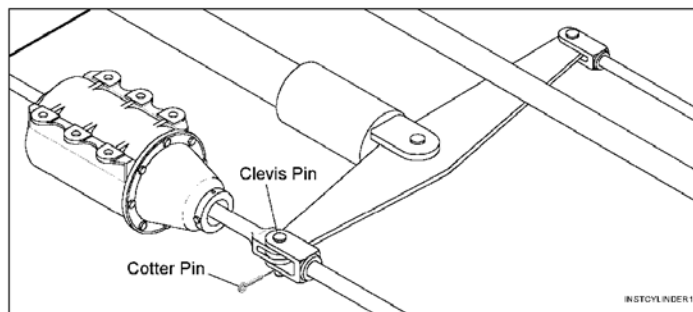

Figure 12: Push Rod Connection

Copyright 2016© New York Air Brake AG. All rights reserved, including industrial property rights applications.
New York Air Brake AG retains any power of disposal, such as copying and transferring.





Repair Track Maintenance
DB-60 Doc.-No.: IP-175
Revision: 07 08/8/2016 - en

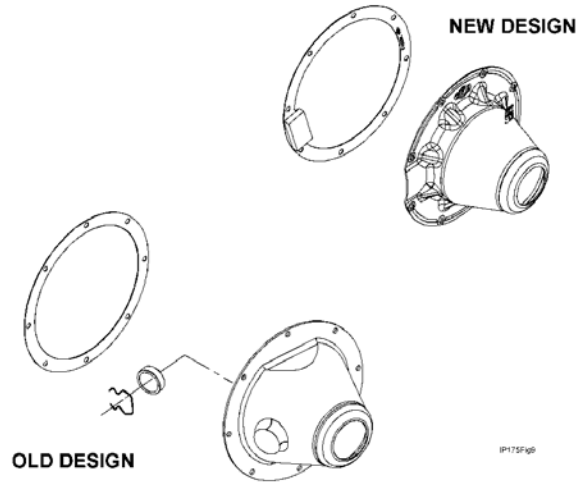

Figure 13: Non-Pressure Heads

Copyright 2016© New York Air Brake AG. All rights reserved, including industrial property rights applications.
New York Air Brake AG retains any power of disposal, such as copying and transferring.



Knorr-Bremse Group

Page 27 | 77



5.4 TRUCK MOUNTED CYLINDERS

5.4.1 NYCOPAC Assembly - With Handbrake, Fig. 15

If the results of the air brake testing confirm that the NYCOPAC brake cylinder is defective, the following steps are used to replace the cylinder assembly.

5.4.1.1 The truck wheels should be chocked to prevent unwanted roll.



WARNING

WARNING

Follow local railroad procedures when removing trucks in order to prevent personal injury.

5.4.1.2 Work done at the car may be accomplished either by jacking the car and rolling truck out or with car over a pit or depressed area between rails.

5.4.1.3 Drain air from all reservoirs and brake cylinders.

5.4.1.4 Disconnect brake cylinder hoses at cylinder flanges. Disconnect hand brake chain.

5.4.1.5 When hoses are disconnected, inspect hoses for over age, abrasion, cracks, soft spots, and loose or defective fittings per rule 5 of the AAR Field Manual. Replace as required.

5.4.1.6 Remove cotter pin (17) and push rod pin (16). Discard cotter pin (17).

5.4.1.7 Push on beam so that it ends up as close to the bolster as possible. Use two wrenches to loosen push rod locking nut (Fig. 14). Unscrew and remove push rod (15) (Fig. 11) and place it on bolster.

5.4.1.8 Inspect push rod (15). If it is damaged, return it to the shop for repair and replace it with one of the same length.



WARNING

WARNING

Brake Cylinder Assembly (11) is under compressive load and will tend to "spring" toward the axle. Examine push rod holder (Figure 10) to determine that it is securely in place before removing nuts (14) (Figure 11) to prevent personal injury.

5.4.1.9 Remove nuts (14) and lock washers (13) from bolts (12). Remove cylinder assembly (11) from beam (1). Remove and discard gasket (10) from beam (1).



NEW YORK AIR BRAKE

Repair Track Maintenance

DB-60

Doc-No: IP-175

Revision: 07 09/6/2016 - en

- 5.4.1.10 Remove brake shoe keys (4) from beam (1). Remove brake shoes (3). Discard brake shoes (3) if they are worn beyond acceptable standards.
- 5.4.1.11 Cylinder assembly (11) must be transported to an AAR approved air brake shop for re-conditioning.
- 5.4.1.12 Suitable containers must be provided and the assembly must be carefully handled at the car and while being transported to and from the car, so that all parts will be effectively protected against damage and contact with any kind of dirt.

NOTICE

NOTE

It is the responsibility of individual railroads to provide adequate protective means.

- 5.4.1.13 **ASSEMBLY** - Clean rust and other dirt from cylinder bolting face on beam (1). Clean spring cavity in beam (1) and install new strainer (2) and new gasket (10).

NOTICE

NOTE

Use a thin film of Brake cylinder lubricant on both sides of spring seat stop flange and on unit body bolting face to hold gasket (10) in place.

- 5.4.1.14 Make certain hollow rod guide gasket of hollow rod guide is in place, align spring seat stop and cylinder body (11) flange bolt holes with those of the unit body making certain spring seat stop drain hole is facing downward.
- 5.4.1.15 Position cylinder assembly (11) in beam (1) cavity. Install two top bolts (12) and lock washers (13) and then start nuts (14). Position the hollow rod guide in beam (1) recess by grasping the push rod end and shifting the beam cylinder assembly until the release spring pushes guide into place. Install lower bolts (12) and tighten all nuts (14) to 135 to 165 ft-lbs dry torque.
- 5.4.1.16 Clean push rod (15) threads and lubricate with brake cylinder lubricant. Turn push rod (15) into push rod end two (2) turns beyond the mark previously placed on push rod (15), align pin holes in push rod with pin holes in beam (1). Insert pin (16) and lock with cotter pin (17).
- 5.4.1.17 Insert spacing blocks (See Fig. 16 for block dimensions) between brake heads of both beams (1) and four wheels as close as possible to the flange (See Fig. 17). If push rod adjustment is necessary to permit spacing block insertion, rotate the push rod end to shorten the push rod (when facing the bolster from the pressure end of brake cylinder and with wrench handle upward, moving the wrench handle to the right will shorten the rod and moving to the left will lengthen the rod).

Copyright 2016© New York Air Brake AG. All rights reserved, including industrial property rights applications.
New York Air Brake AG retains any power of disposal, such as copying and transferring.



Knorr-Bremse Group

Page 29 / 77



- 5.4.1.18 Adjust both push rods to snug spacing blocks against wheels by rotating both push rod ends to lengthen push rods. After both push rods have been snugged with spacing blocks against wheels, rotate both push rod ends 1/2 turn to the right to shorten the rod for easy spacing block removal.
- 5.4.1.19 Remove spacing blocks and install brake shoes (3) onto beam (1) (If new shoes are being mounted, use only 1-1/4" or 1-1/2" thick shoes). Insert brake shoe keys (4) to hold brake shoes (3) to beams (1). Tighten push rod locking nut securely (See Fig. 14). Replace strainer (5), and gasket (6) and reattach BC hose (7) with bolts (8 & 9) and torque grade 5 bolts to 55 +/- 5 ft-lbs dry torque.
- 5.4.1.20 **TESTING** - After all repairs have been completed, the brake cylinder must be tested per Rule 3 of the AAR Field Manual.
- 5.4.1.21 For reconditioning the NYCOPAC Cylinder, refer to New York Air Brake Repair Procedure NYR-105 latest revision. Copies may be obtained through any Field Office.

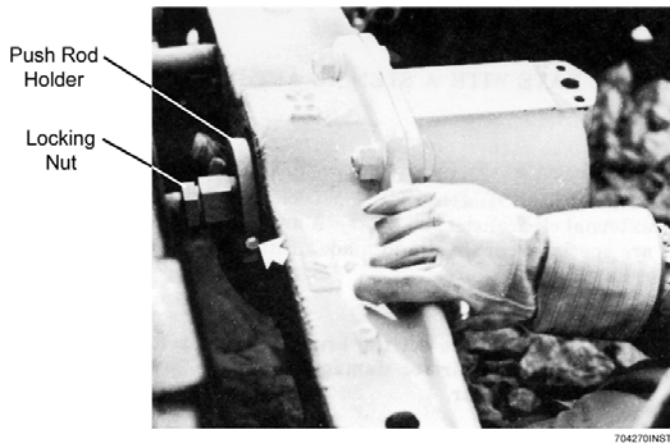

Figure 14: Push Rod Holder and Locking Nuts



Repair Track Maintenance
DB-60 Doc.-No.: IP-175
Revision: 07 08/8/2016 - en

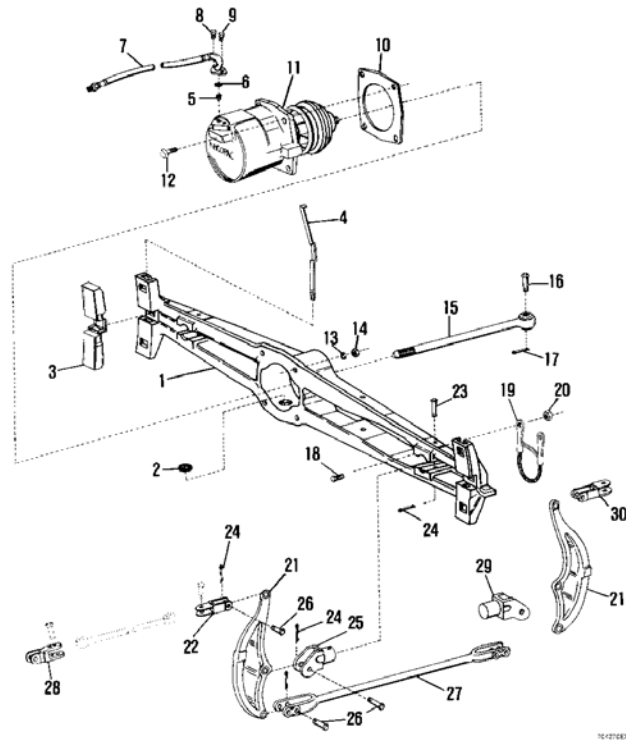
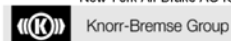

Figure 15: NYCOPAC Assembly with Handbrake

Copyright 2016© New York Air Brake AG. All rights reserved, including industrial property rights applications.
New York Air Brake AG retains any power of disposal, such as copying and transferring.





Repair Track Maintenance
 DB-60 Doc. No.: IP-175
 Revision: 07 08/8/2016 - en

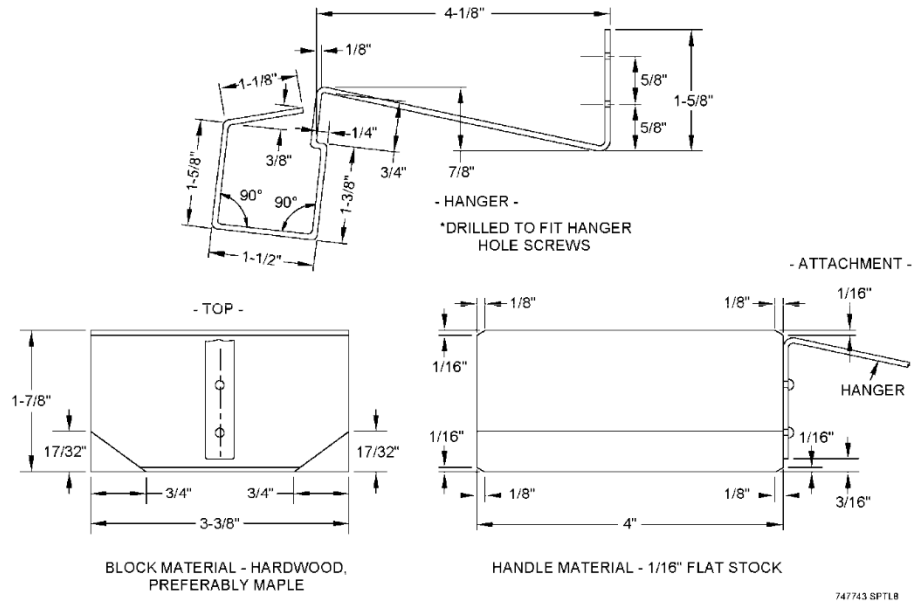

Figure 16: Spacing Block and Hanger Dimensions



Figure 17: Spacing Block Placement

Copyright 2016© New York Air Brake AG. All rights reserved, including industrial property rights applications.
 New York Air Brake AG retains any power of disposal, such as copying and transferring.





NEW YORK AIR BRAKE

Repair Track Maintenance

DB-60

Doc.-No.: IP-175

Revision: 07 08/6/2016 - en

- 5.4.1.22 NYCOPAC HAND BRAKE ADJUSTMENT, Fig. 18 - Perform on new cars, after any new or turned wheel replacements, and after truck replacements.
- 5.4.1.23 Release hand brake fully. The horizontal hand brake chain should have minimal slack. If so, hand brake adjustment is proper. If not so, proceed to step 5.4.1.24.
- 5.4.1.24 Disconnect adjustment pin at anchor clevis. Pull on pull rod by hand and insert pin in farthest hole possible. If this action brings horizontal chain to have minimal slack, slack adjustment is proper. If the chain is still loose, move back one (1) hole, then make adjustment at bottom rod as in step 5.4.1.25.
- 5.4.1.25 If necessary, as in step 5.4.1.24, move pin at one end of bottom rod to outside hole. This action should bring horizontal chain taut. If not, tighten chain at anchor clevis as in step 5.4.1.24.

NOTICE

NOTE

Movement of the pin at the anchor clevis one hole towards the body anchor (from hole 'L' to hole 'K') will shorten the horizontal chain travel approximately 3". Movement of the pin at the bottom connecting rod one hole towards the end of the rod (from hole 'A' to hole 'B') will shorten the chain travel 4-3/8".

- 5.4.1.26 The brake assembly handbrake can be adjusted to compensate for shoe and wheel wear through pin connections at connecting rod and anchor clevis. The connecting rod length can be varied by means of the two holes, 1-3/4" apart at each end (ref. A & B). The anchor clevis can also be adjusted in this manner. It contains two holes 3" apart (ref. K & L) for maximum adjustment. The table in step 5.4.1.28 shows the adjustments that are obtained by connecting these holes in accordance with the letter code indicated.
- 5.4.1.27 The anchor clevis can also be adjusted in this manner. It contains two holes 3" apart (ref. K & L) for maximum adjustment. The table in step 5.4.1.28 shows the adjustments that are obtained by connecting these holes in accordance with the letter code indicated.

Copyright 2016© New York Air Brake AG. All rights reserved, including industrial property rights applications.
New York Air Brake AG retains any power of disposal, such as copying and transferring.



Knorr-Bremse Group

Page 33 / 77



Repair Track Maintenance
 DB-60 Doc-No: IP-175
 Revision: 07 08/6/2016 - en

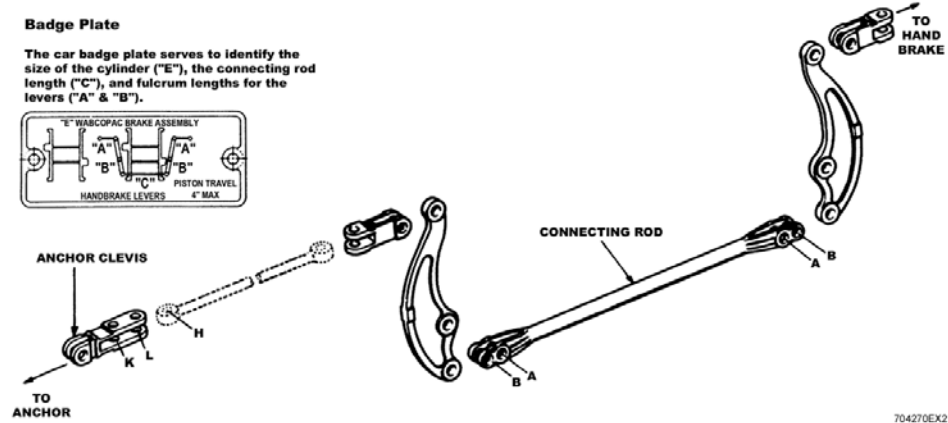

Figure 18: NYCOPAC Hand Brake Adjustment

5.4.1.28 Hand brake adjustment table:

CONNECTION CODE	COMPENSATION AT EACH SHOE	EQUIVALENT HORIZONTAL CHAIN TRAVEL
HLAA	NORMAL	NORMAL
HKAA	7/16"	3"
HLBA	5/8"	4-3/8"
HKBA	1-1/16"	7-3/8"
HLBB	1-1/4"	8-3/4"
HKBB	1-11/16"	11-3/4"

5.4.2 NYCOPAC II Assembly - With Handbrake (Truck set), Fig. 19

If the results of the air brake testing confirm that the NYCOPAC II brake cylinder is defective, the following steps are used to replace the cylinder assembly.

5.4.2.1 The truck wheels should be chocked to prevent unwanted roll.

WARNING

WARNING
 Follow local railroad procedures when removing trucks in order to prevent personal injury.

Copyright 2016© New York Air Brake AG. All rights reserved, including industrial property rights applications. New York Air Brake AG retains any power of disposal, such as copying and transferring.



Repair Track Maintenance
DB-60 Doc-No: IP-175
Revision: 07 08/6/2016 - en

- 5.4.2.2 Work done at the car may be accomplished either by jacking the car and rolling truck out or with car over a pit or depressed area between rails.
- 5.4.2.3 Drain air from all reservoirs and brake cylinders.
- 5.4.2.4 Disconnect brake cylinder hoses at cylinder flanges.
- 5.4.2.5 When hoses are disconnected, inspect hoses for over age, abrasion, cracks, soft spots, and loose or defective fittings per rule 5 of the AAR Field Manual. Replace as required.
- 5.4.2.6 With a bar, pry on levers (12) or shoes (15) so that cylinder (13) is fully retracted.
- 5.4.2.7 Remove brake shoe key (14) from primary beam (1) and secondary beam (3). Remove brake shoe (15).

FOR CYLINDERS EQUIPPED WITH HANDBRAKE CABLES: (Step 5.4.2.8 thru 5.4.2.9)

- 5.4.2.8 Remove the cotter pins and clevis pins attaching the clevis end of the cables to the equalizing plate that the chain pulls on.
- 5.4.2.9 Loosen the cable locknut holding the cable to the car bracket and remove the cable from the bracket.
- 5.4.2.10 To remove cylinder (13), remove and discard cotter pin (5) from pin (4).
- 5.4.2.11 Remove two pins (4). Remove cylinder (13).
- 5.4.2.12 The assembly must be transported to an AAR approved air brake shop for reconditioning.
- 5.4.2.13 Suitable containers must be provided and the assembly must be carefully handled at the car and while being transported to and from the car, so that all parts will be effectively protected against damage and contact with any kind of dirt.

NOTICE	NOTE It is the responsibility of individual railroads to provide adequate protective means.
---------------	---

NOTICE	NOTE Brake Cylinder ram is to be fully retracted before installation.
---------------	---

- 5.4.2.14 **ASSEMBLY** - Install brake cylinder (13) onto lever (12). Insert pin (4) into cylinder (13) and lever (12). Insert new cotter pin (5) into pin (4).

Copyright 2016© New York Air Brake AG. All rights reserved, including industrial property rights applications.
New York Air Brake AG retains any power of disposal, such as copying and transferring.

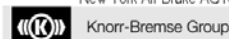



Repair Track Maintenance
DB-60 Doc-No: IP-175
Revision: 07 08/6/2016 - en

FOR CYLINDERS EQUIPPED WITH HANDBRAKE CABLES: (Step 5.4.2.15 thru 5.4.2.16)

NOTICE	NOTE A cable bend of not less than 10" minimum is required for proper installation.
---------------	---

- 5.4.2.15 Attach cables to car mounting bracket by placing one nut and one washer on each side of the bracket. Then tighten nuts snugly.
- 5.4.2.16 Attach clevis end of cable to the equalizer chain bracket with clevis pins and cotter pins.
- 5.4.2.17 Install brake shoes (15) onto both primary beam (1) and secondary beam (3). Insert brake shoe key (14) to hold brake shoes (15) to beams (1 & 3).
- 5.4.2.18 With the brake cylinder fully retracted, check that the total shoe clearance is within 2" (i.e. 1/2" clearance between each shoe and wheel). Adjust if necessary by removing two shoes (15) from secondary beam (3). Remove clevis pins (4) connecting rod end (7) to secondary beam (3). Lengthen or shorten connecting rod ends (7) as necessary - one complete turn gives approximately 1/8" change in rod length. Reassemble and repeat this step. Replace filter screen.
- 5.4.2.19 Replace strainer and gasket to the hose connection, then reconnect the brake cylinder hose. Torque the hose attaching grade 5 bolts to 55 +/- 5 ft-lbs dry torque.
- 5.4.2.20 **TESTING** - After all repairs have been completed, the brake cylinder must be tested per Rule 3 of the AAR Field Manual.
- 5.4.2.21 For reconditioning the NYCOPAC II Cylinder, refer to New York Air Brake Repair Procedure NYR-283, NYR-284 and NYR-285 latest revisions. Copies may be obtained through any Field Office.

Copyright 2016© New York Air Brake AG. All rights reserved, including industrial property rights applications.
New York Air Brake AG retains any power of disposal, such as copying and transferring.

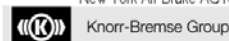



Repair Track Maintenance
DB-60 Doc-No: IP-175
Revision: 07 08/6/2016 - en

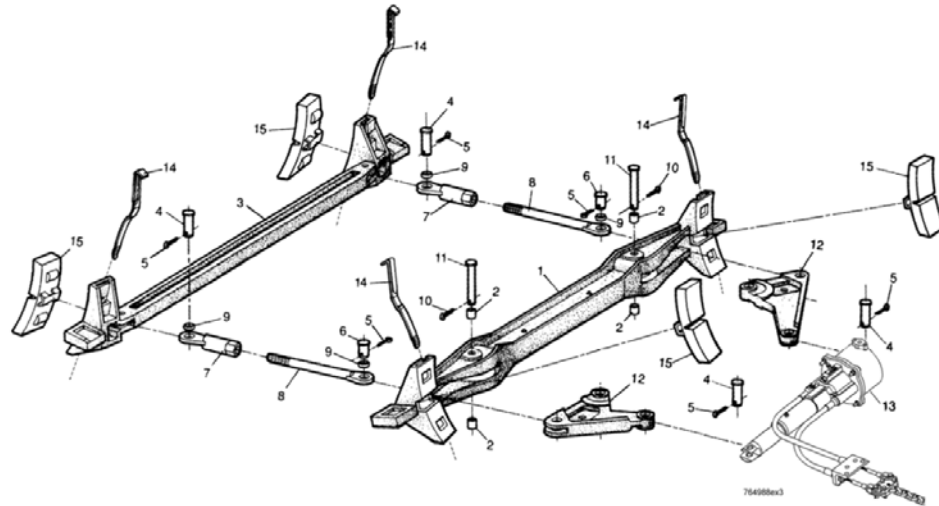



Figure 19: NYCOPAC II Assembly with Handbrake (Truck Set)

5.4.3 NYCOPAC IIA Assembly - With Handbrake (Truck Set), Fig. 20

If the results of the air brake testing confirm that the NYCOPAC IIA brake cylinder is defective, the following steps are used to replace the cylinder assembly.

5.4.3.1 The truck wheels should be chocked to prevent unwanted roll.

 WARNING	WARNING Follow local railroad procedures when removing trucks in order to prevent personal injury.
--	--

5.4.3.2 Work done at the car may be accomplished either by jacking the car and rolling truck out or with car over a pit or depressed area between rails.

5.4.3.3 Drain air from all reservoirs and brake cylinders.

5.4.3.4 Disconnect brake cylinder hoses at cylinder flanges. Disconnect hand brake chain.

5.4.3.5 When hoses are disconnected, inspect hoses for over age, abrasion, cracks, soft spots, and loose or defective fittings per rule 5 of the AAR Field Manual. Replace as required.

5.4.3.6 With a bar, pry on levers (9) or shoes (22) so that cylinder (23) is fully retracted.

Copyright 2016© New York Air Brake AG. All rights reserved, including industrial property rights applications.
New York Air Brake AG retains any power of disposal, such as copying and transferring.

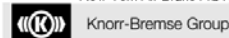



- 5.4.3.7 Remove brake shoe keys (21) from beams (6). Remove and discard brake shoes (22).
- 5.4.3.8 Remove four hex nuts (43) and four lockwashers (44) that attach link (42) to cylinder assembly (23). Remove link (42) from cylinder assembly (23).
- 5.4.3.9 Remove the two hex screws (29) and locking plates (30) from both sides of gimbal (32). Discard locking plates (30).
- 5.4.3.10 Remove cylinder assembly (23) from gimbal (32).
- 5.4.3.11 The assembly must be transported to an AAR approved air brake shop for reconditioning.
- 5.4.3.12 Suitable containers must be provided and the assembly must be carefully handled at the car and while being transported to and from the car, so that all parts will be effectively protected against damage and contact with any kind of dirt.

NOTICE	NOTE It is the responsibility of individual railroads to provide adequate protective means.
---------------	---

- 5.4.3.13 Inspect gimbal (32) for damage or wear. If damaged or excessive wear is noted in any way, the gimbal (32) must be repaired or replaced.
- 5.4.3.14 Inspect bushings (31). If damaged or excessive wear is noted, the gimbal (32) must be replaced or repaired. If repair is necessary, use the proper tools to press bushings (31) from gimbal (32). Press new bushings (31) into place in gimbal (32).

NOTICE	NOTE Brake Cylinder ram is to be fully retracted before installation.
---------------	---

- 5.4.3.15 **ASSEMBLY** - Install cylinder assembly (23) into gimbal (32) and secure in place with new locking plates (30) and hex screws (29). Torque screws (29) to 135 to 165 ft lb dry torque. Bend locking tabs on one side of the screws (29).
- 5.4.3.16 Attach link assembly (42) to cylinder assembly (23) with lock washers (44) and hex nuts (43). Torque hex nuts (43) to 28 to 32 ft lb dry torque.
- 5.4.3.17 Replace strainer (28) and gasket (27) to the hose connection, then reconnect the brake cylinder hose attaching grade 5 bolts (25 & 26) and torque to 55 +/- 5 ft-lbs dry torque.

NOTICE	NOTE 2" composition shoes must be used on brake heads.
---------------	--

- 5.4.3.18 Install three new shoes (22) onto brake heads securing with key (21).





NEW YORK AIR BRAKE

Repair Track Maintenance

DB-60

Doc-No: IP-175

Revision: 07 08/6/2016 - en

- 5.4.3.19 With new wheels and the three brake shoes pressed tightly against the wheels, the clearance at the remaining brake head will be approximately 3-1/2". If worn wheels are used, clearance should be greater by the amount worn from the four wheels.
- 5.4.3.20 If clearance is inadequate or excessive between brake head and wheel, readjust rod end (40) and push rod (3), using steps 5.4.3.21 thru 5.4.3.26.
- 5.4.3.21 Remove pin (1) from rod end (40) and lever transfer (37).
- 5.4.3.22 Rotate rod end (40) in or out on push rod (3) to obtain proper clearance.

NOTICE

NOTE

One revolution of rod end gives approximately 1/8" change in rod length.

- 5.4.3.23 Insert rod end (40) into lever transfer (37) and install pin (1).
- 5.4.3.24 Repeat steps 5.4.2.18 through 5.4.2.22 to check for proper clearance.
- 5.4.3.25 Install fourth brake shoe (22) into brake head, securing with key (21).
- 5.4.3.26 Install all cotter pins (2) into pins (1) and bend.
- 5.4.3.27 **TESTING** - After all repairs have been completed, the brake cylinder must be tested per Rule 3 of the AAR Field Manual.
- 5.4.3.28 For reconditioning the NYCOPAC IIA Cylinder, refer to New York Air Brake Repair Procedures NYR-374 and NYR-376. Copies may be obtained through any Field Office.

Copyright 2016© New York Air Brake AG. All rights reserved, including industrial property rights applications.
New York Air Brake AG retains any power of disposal, such as copying and transferring.



Knorr-Bremse Group

Page 39 / 77



Repair Track Maintenance
DB-60 Doc.-No.: IP-175
Revision: 07 08/8/2016 - en

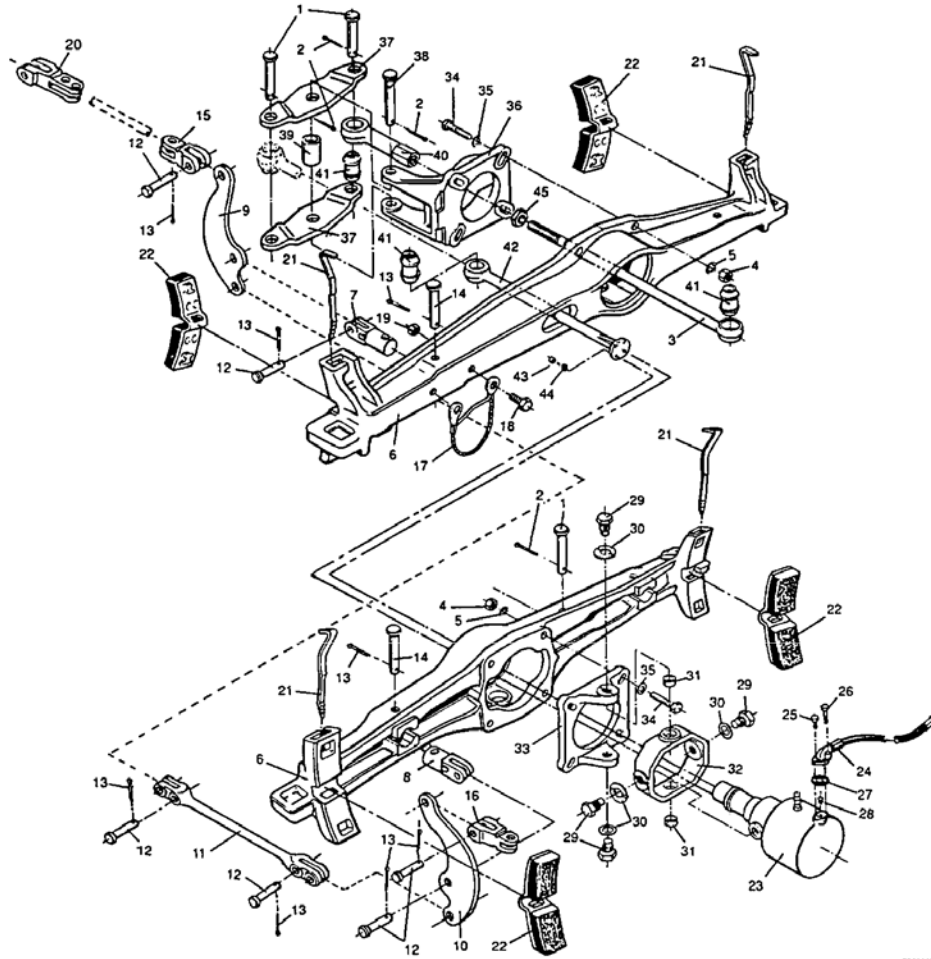

775286X1

Figure 20: NYCOPAC IIA Assembly with Handbrake (Truck Set)

Copyright 2016© New York Air Brake AG. All rights reserved, including industrial property rights applications.
New York Air Brake AG retains any power of disposal, such as copying and transferring.



Knorr-Bremse Group

Page 40 | 77



5.4.4 TMB-60 Truck Mounted Brake System - With Handbrake, Fig. 21

If the results of the air brake testing confirm that the TMB-60 brake cylinder is defective, the following steps are used to replace the cylinder assembly.

5.4.4.1 The truck wheels should be chocked to prevent unwanted roll.

 WARNING	WARNING Follow local railroad procedures when removing trucks in order to prevent personal injury.
--	--

5.4.4.2 Work done at the car may be accomplished either by jacking the car and rolling truck out or with car over a pit or depressed area between rails.

5.4.4.3 Drain air from all reservoirs and brake cylinders.

5.4.4.4 Place a large pry bar between the center of any brake shoe [preferably on the Secondary beam assembly (8)] and the wheel. Using the pry bar, force the brake shoe away from the wheel. Repeat this on the opposite side of beam (8) using a block placed between the wheel and the shoe on the side just separated to increase the clearance with the wheels, thus retracting the double acting slack adjuster inside the brake cylinder.

5.4.4.5 Disconnect brake cylinder hose at cylinder flange and disconnect hand brake cables by removing cotter pins (18) and cable pins (17).

5.4.4.6 When hoses are disconnected, inspect hoses for over age, abrasion, cracks, soft spots, and loose or defective fittings per rule 5 of the AAR Field Manual. Replace as required.

FOR CYLINDERS EQUIPPED WITH CABLES: (Steps 5.4.4.7 thru 5.4.4.9)

5.4.4.7 Disconnect both cables from the two equalizer plates (20) removing cotter pins (18) and pins (17).

5.4.4.8 Remove hex head cap screws (21) and lock nuts (22). Remove chain (23) from between two equalizer plates (20).

5.4.4.9 Loosen the cable locknut holding the cable to the car bracket (19) and remove the cable from bracket (19).

FOR CYLINDERS EQUIPPED WITH MECHANICAL HANDBRAKE: (Step 5.3.3.10)

5.4.4.10 Remove the chain from the lever.

5.4.4.11 Remove cotter pins (7) and pins (10) from levers (6). Remove cylinder assembly (12) from levers (6).

5.4.4.12 Remove brake shoe keys (13) from beams (1 & 8). Remove brake shoes (14). Discard brake shoes (14) if they are worn beyond acceptable standards.

5.4.4.13 Cylinder assembly (12) must be transported to an AAR approved air brake shop for reconditioning.

Copyright 2016© New York Air Brake AG. All rights reserved, including industrial property rights applications.
New York Air Brake AG retains any power of disposal, such as copying and transferring.





Repair Track Maintenance
DB-60 Doc-No: IP-175
Revision: 07 08/6/2016 - en

5.4.4.14 Suitable containers must be provided and the assembly must be carefully handled at the car and while being transported to and from the car, so that all parts will be effectively protected against damage and contact with any kind of dirt.

NOTICE	NOTE It is the responsibility of individual railroads to provide adequate protective means.
---------------	---

5.4.4.15 **ASSEMBLY** - Install cylinder assembly (12) onto levers (6). Secure cylinder assembly (12) to levers (6) using pins (10) and cotter pins (7).

NOTICE	NOTE Brake Cylinder ram is to be fully retracted before installation.
---------------	---

5.4.4.16 Install new 2" brake shoes (14) to brake heads (4) on beam assemblies (1 & 8). Insert brake keys (13) to hold shoes (14) to the removable brake heads (4).

5.4.4.17 Replace the air hose ring gasket, then connect air hose to 1/2" flange on top of cylinder (12). Torque grade 5 bolts to 55 +/- 5 ft-lbs dry torque.

FOR CYLINDERS EQUIPPED WITH CABLES: (Steps 5.4.4.18 thru 5.4.4.21)

NOTICE	NOTE A cable bend of not less than 10" minimum is required for proper installation.
---------------	---

5.4.4.18 Attach cables to mounting bracket (19) by placing one nut and one washer on each side of bracket (19). Tighten the nuts snugly.

5.4.4.19 Insert chain (23) between two equalizer plates (20) and secure in place using hex head cap screws (21) and lock nuts (22). Do not tighten nut (22) until cables are connected to other end of equalizer (20).

5.4.4.20 Connect both cables to the two equalizer plates (20) using pins (17) and cotter pins (18).

5.4.4.21 Torque lock nuts (21) to 35 +/- 2 ft lb dry torque.

FOR CYLINDERS EQUIPPED WITH MECHANICAL HANDBRAKE: (Step 5.4.4.22)

5.4.4.22 Connect the chain to the lever.

WARNING	WARNING To avoid personal injury from movement of the various parts when operating the system, all personnel must be clear of truck and brake pads before the cylinder is pressurized.
----------------	--

Copyright 2016© New York Air Brake AG. All rights reserved, including industrial property rights applications.
New York Air Brake AG retains any power of disposal, such as copying and transferring.

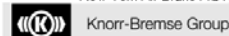



NEW YORK AIR BRAKE

Repair Track Maintenance
DB-60 Doc-No: IP-175
Revision: 07 08/6/2016 - en

- 5.4.4.23 Apply 20 to 50 psi air pressure to cylinder assembly (12). Cycle cylinder (12) two to three times to insure the nominal 2" piston travel is achieved. The slack adjuster will automatically adjust the operating brake shoe clearance to the correct distance. Release air pressure.
- 5.4.4.24 **TESTING** - After all repairs have been completed, the brake cylinder must be tested per Rule 3 of the AAR Field Manual.

NOTICE

NOTE

TMB-60 cylinders have approximately 2" working piston stroke at 50 psi brake cylinder pressure. The slack adjuster located inside of the cylinder is double acting. It automatically maintains a constant piston travel by taking up or letting out slack with each brake application. The piston stroke indicator is mounted on top of the pneumatic cylinder.

- 5.4.4.25 For reconditioning the TMB-60 Brake Cylinder, return to New York Air Brake by contacting any Field Office.

Copyright 2016© New York Air Brake AG. All rights reserved, including industrial property rights applications.
New York Air Brake AG retains any power of disposal, such as copying and transferring.



Knorr-Bremse Group

Page 43 / 77



Repair Track Maintenance
 DB-60 Doc.-No.: IP-175
 Revision: 07 09/6/2016 - en

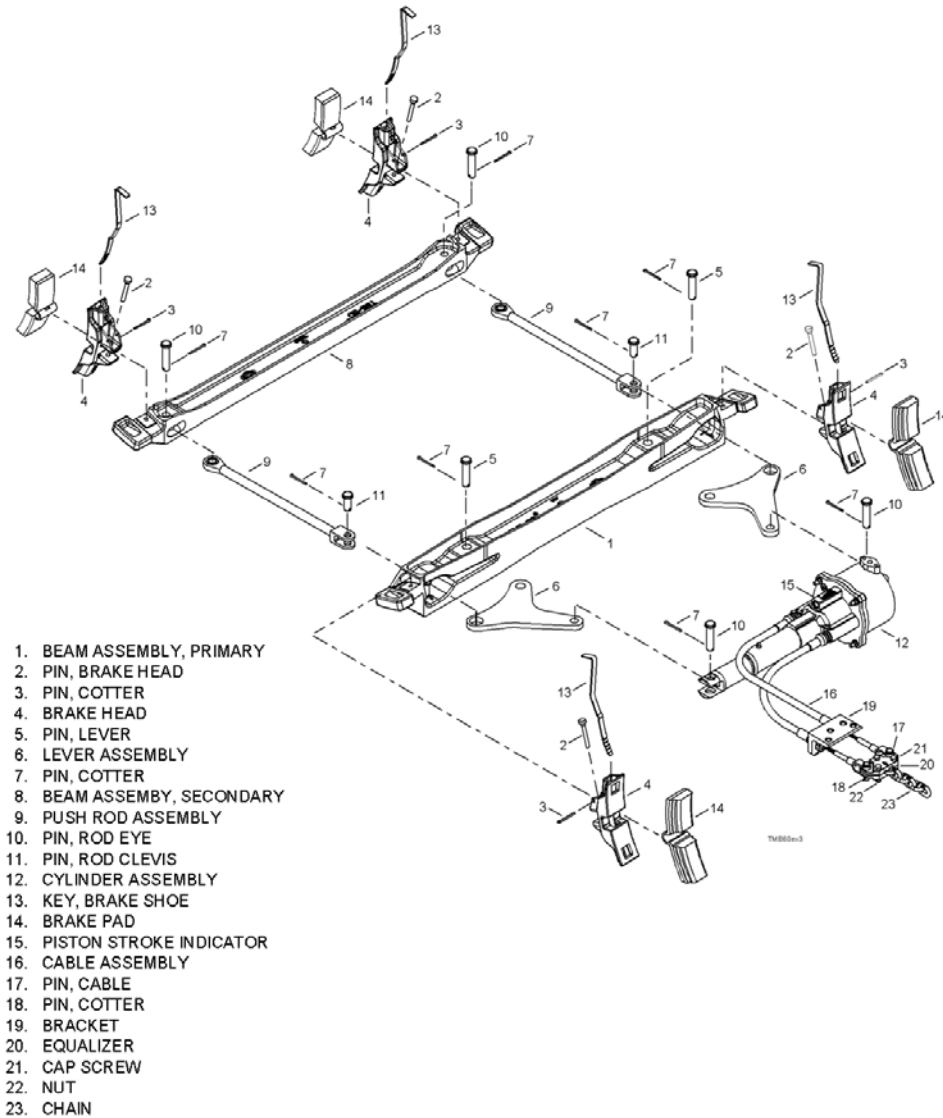
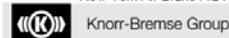

Figure 21: TBM-60 Truck Mounted Brake System with Handbrake

Copyright 2016© New York Air Brake AG. All rights reserved, including industrial property rights applications.
 New York Air Brake AG retains any power of disposal, such as copying and transferring.





5.5 VENT VALVE, Fig. 22 and 23

If the results of the air brake testing confirm that the vent valve portion is defective, the following steps are used to replace the vent valve portion.

- 5.5.1 Drain the air out of the auxiliary reservoir, emergency reservoir, brake cylinder and brake pipe.
- 5.5.2 Scrape, wipe and blow off all dirt adjacent to the gaskets between the pipe bracket and the valve portion. Use the air hose, blow off all loose dirt on the valve portion, pipe bracket, truck frame, car under-frame, etc., that may otherwise get into the valve portion or bracket when the portion is being removed and cleaned portion applied.
- 5.5.3 Remove the vent valve portion and apply protective port covering for shipping.
- 5.5.4 The vent valve portion must be carefully handled to avoid entrance of dirt, water or damage to internal parts.
- 5.5.5 When the valve portion is removed and conditions are found in the portion or the pipe bracket evidencing that the car brake equipment has been submerged in water, special additional cleaning operations not regularly performed will be required as directed in Section 7.0.
- 5.5.6 Pipe bracket gasket and filter screen must be replaced with new ones.
- 5.5.7 The protective port coverings must not be removed from the clean vent valve portion until prepared to immediately mount the portion on the pipe bracket.
- 5.5.8 Remove the protective port covering from the clean vent valve portion and ensure that the gasket is in place and fully seated. Immediately mount the portion, sliding it slowly and carefully on the studs against the pipe bracket, then, tighten the mounting nuts evenly to 50 +/- 5 ft. lb. dry torque.
- 5.5.9 If the flange connection at the mounting bracket needs to be removed, the ring gaskets must be replaced and the 5/8" grade 2 bolts torqued to 70 +/- 5 ft lbs dry torque.
- 5.5.10 **Required Orientation:**
As shown in **Figures 22 and 23**, bowl facing down, no obstruction near exhaust port.
- 5.5.11 **TESTING** - After all repairs have been completed, the vent valve must be tested per rule 3 of the AAR Field Manual.
- 5.5.12 For reconditioning the vent valve, refer to New York Air Brake Repair Procedures NYR-110 and NYR-158. Copies may be obtained through any Field Office.





Repair Track Maintenance
DB-60 Doc.-No.: IP-175
Revision: 07 08/6/2016 - en

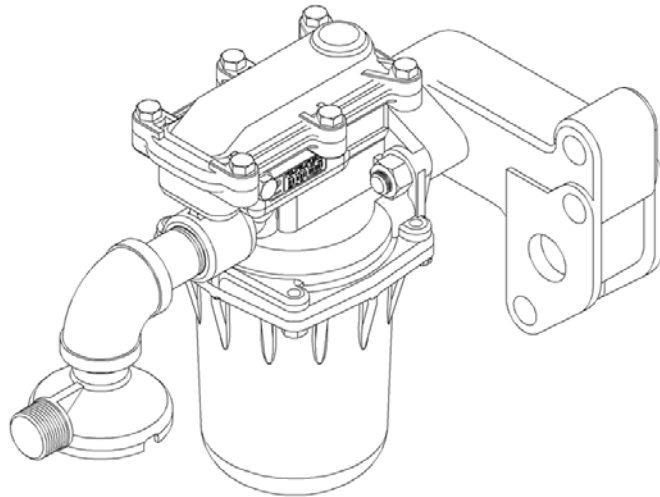

Figure 22: KM-2 Vent Valve

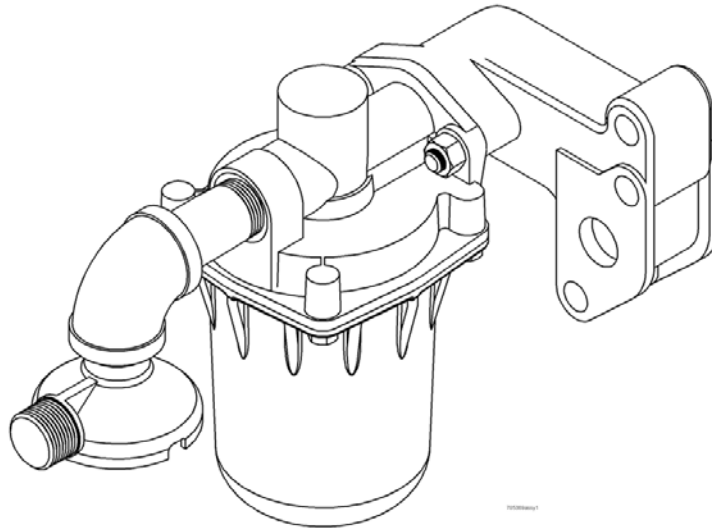
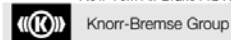

Figure 23: No. 8 Vent Valve

Copyright 2016© New York Air Brake AG. All rights reserved, including industrial property rights applications.
New York Air Brake AG retains any power of disposal, such as copying and transferring.





NEW YORK AIR BRAKE

Repair Track Maintenance
DB-60 Doc.-No.: IP-175
Revision: 07 08/8/2016 - en

5.6 ANGLE COCK, Fig. 24

If the results of the air brake testing confirm that the angle cock is defective, the following steps are used to replace the angle cock.

- 5.6.1 Drain the air out of the brake pipe.
- 5.6.2 Scrape, wipe and blow off all dirt adjacent to the angle cock. Use the air hose, blow off all loose dirt on the angle cock, truck frame, car underframe, etc., that may otherwise get into the angle cock when it is being removed and cleaned portion applied.
- 5.6.3 Remove the angle cock and apply protective port covering for shipping.
- 5.6.4 The angle cock must be carefully handled to avoid entrance of dirt, water or damage to internal parts.
- 5.6.5 When the angle cock is removed and conditions are found in the portion or the brake pipe evidencing that the car brake equipment has been submerged in water, special additional cleaning operations not regularly performed will be required as directed in Section 7.0.
- 5.6.6 The gripseal must be replaced with a new one.
- 5.6.7 The protective port coverings must not be removed from the clean angle cock until prepared to immediately mount the portion on the brake pipe.
- 5.6.8 Coat the threads of the brake pipe with Loctite #592 thread sealant to prevent leakage. Remove the protective port covering from the clean angle cock. Immediately mount the angle cock to the brake pipe and tighten firmly, then tighten the gripseal and nut to the brake pipe connection end of the angle cock.
- 5.6.9 **TESTING** - After all repairs have been completed, the angle cock must be tested per rule 3 of the AAR Field Manual.
- 5.6.10 For reconditioning the angle cock, refer to New York Air Brake Repair Procedure NYR-432. Copies may be obtained through any Field Office.

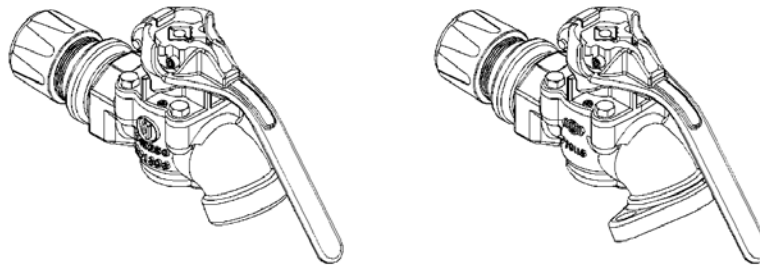

779117AGSY2

Figure 24: Standard and Flanged Gripseal Angle Cocks

Copyright 2016© New York Air Brake AG. All rights reserved, including industrial property rights applications.
New York Air Brake AG retains any power of disposal, such as copying and transferring.



Knorr-Bremse Group

Page 47 | 77



5.7 END COCK, Fig 25

If the results of the air brake testing confirm that the end cock is defective, the following steps are used to replace the end cock.

- 5.7.1 Drain the air out of the brake pipe.
- 5.7.2 Scrape, wipe and blow off all dirt adjacent to the end cock. Use the air hose, blow off all loose dirt on the end cock, truck frame, car under frame, etc., that may otherwise get into the end cock when it is being removed and cleaned portion applied.
- 5.7.3 Remove the end cock and apply protective port covering for shipping.
- 5.7.4 The end cock must be carefully handled to avoid entrance of dirt, water or damage to internal parts.
- 5.7.5 When the end cock is removed and conditions are found in the portion or the brake pipe evidencing that the car brake equipment has been submerged in water, special additional cleaning operations not regularly performed will be required as directed in Section 7.0.
- 5.7.6 The protective port coverings must not be removed from the clean end cock until prepared to immediately mount the portion on the flange connected to brake pipe.
- 5.7.7 Install a new gasket on the flange mounted to brake pipe. Remove the protective port covering from the clean end cock. Immediately mount the end cock to the flange and tighten the 5/8" grade 2 bolts to 70 +/- 5 ft-lbs dry torque.
- 5.7.8 **TESTING** - After all repairs have been completed, the end cock must be tested per rule 3 of the AAR Field Manual.
- 5.7.9 For reconditioning the end cock, refer to New York Air Brake Repair Procedure NYR-438. Copies may be obtained through any Field Office.

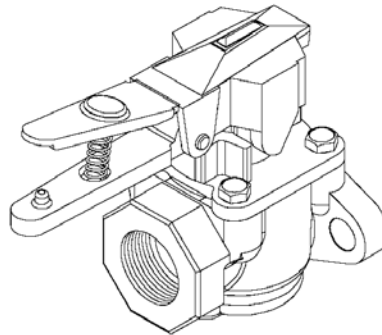

Figure 25: End Cock

Copyright 2016© New York Air Brake AG. All rights reserved, including industrial property rights applications.
New York Air Brake AG retains any power of disposal, such as copying and transferring.



Knorr-Bremse Group

Page 48 | 77



5.8 DIRT COLLECTOR CUT-OUT COCK, Fig. 26

If the results of the air brake testing confirm that the dirt collector cut-out cock is defective, the following steps are used to replace the dirt collector cut-out cock.

- 5.8.1 Drain the air out of the brake pipe.
- 5.8.2 Scrape, wipe and blow off all dirt adjacent to the gaskets between the pipe bracket and the dirt collector cut-out cock. Use the air hose, blow off all loose dirt on the dirt collector cut-out cock, pipe bracket, truck frame, car under-frame, etc., that may otherwise get into the dirt collector cut-out cock or bracket when the portion is being removed and cleaned portion applied.
- 5.8.3 Remove the dirt collector cut-out cock and apply protective port covering for shipping.
- 5.8.4 The dirt collector cut-out cock must be carefully handled to avoid entrance of dirt, water or damage to internal parts.
- 5.8.5 When the dirt collector cut-out cock is removed and conditions are found in the portion or the pipe bracket evidencing that the car brake equipment has been submerged in water, special additional cleaning operations not regularly performed will be required as directed in Section 7.0.
- 5.8.6 Gaskets must be replaced with new ones.
- 5.8.7 The protective port coverings must not be removed from the clean dirt collector cut-out cock until prepared to immediately mount the portion on the pipe bracket.
- 5.8.8 Remove the protective port covering from the clean dirt collector cut-out cock and ensure that the new gaskets are in place and fully seated. Immediately mount the portion. Tighten the bolts to the pipe bracket evenly to 55 +/- 5 ft. lb. dry torque for cast iron pipe brackets and 40 +/- 5 ft lbs dry torque for aluminum pipe brackets.
- 5.8.9 Install a new ring gasket at the flange connection and tighten the 1/2" grade 5 bolts to 55 +/- 5 ft lbs dry torque.
- 5.8.10 **TESTING** - After all repairs have been completed, the dirt collector cut-out cock must be tested per rule 3 of the AAR Field Manual.
- 5.8.11 For reconditioning the dirt collector cut out cock, refer to New York Air Brake Repair Procedure NYR-235. Copies may be obtained through any Field Office





Repair Track Maintenance
DB-60 Doc-No: IP-175
Revision: 07 08/6/2016 - en

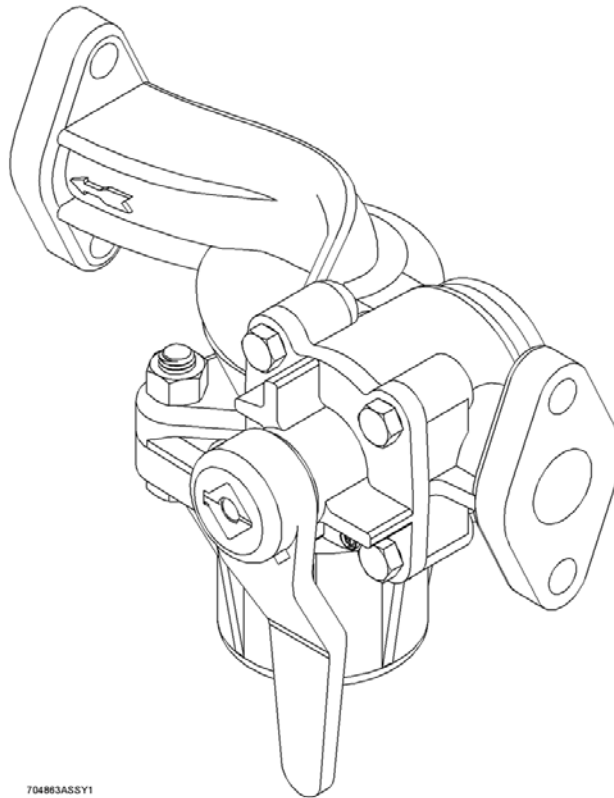

704863ASSY1

Figure 26: Dirt Collector Cut-Out Cock

Copyright 2016© New York Air Brake AG. All rights reserved, including industrial property rights applications.
New York Air Brake AG retains any power of disposal, such as copying and transferring.

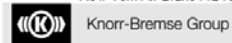



5.9 RETAINING VALVE, Fig. 27 and 28

If the results of the air brake testing confirm that the retaining valve is defective, the following steps are used to replace the retaining valve.

- 5.9.1 Drain the air out of the auxiliary reservoir, emergency reservoir, brake cylinder and brake pipe.
- 5.9.2 Scrape, wipe and blow off all dirt adjacent to the gaskets between the retaining valve pipe bracket and the retaining valve. Use the air hose, blow off all loose dirt on the valve portion, pipe bracket, truck frame, car under-frame, etc., that may otherwise get into the valve portion or bracket when the portion is being removed and cleaned portion applied.
- 5.9.3 Remove the retaining valve and apply protective port covering for shipping.
- 5.9.4 The retaining valve must be carefully handled to avoid entrance of dirt, water or damage to internal parts.
- 5.9.5 When the retaining valve is removed and conditions are found in the portion or it's pipe bracket evidencing that the car brake equipment has been submerged in water, special additional cleaning operations not regularly performed will be required as directed in Section 7.0.
- 5.9.6 Pipe bracket gasket and filter screen must be replaced with new ones.
- 5.9.7 The protective port coverings must not be removed from the clean retaining valve until prepared to immediately mount the portion on it's pipe bracket.
- 5.9.8 Remove the protective port covering from the clean retaining valve and ensure that the gasket is in place and fully seated. Immediately mount the portion. Tighten the bolts evenly to 18 to 22 ft. lb. dry torque.
- 5.9.9 If the flange connection at the mounting bracket needs to be removed, the ring gasket must be replaced and 3/8" grade 5 bolts tightened to 18 +/- 2 ft lbs dry torque.
- 5.9.10 **TESTING** - After all repairs have been completed, the retaining valve must be tested per rule 3 of the AAR Field Manual.
- 5.9.11 For reconditioning the retaining valve, refer to New York Air Brake Repair Procedures NYR-270 and NYR-402. Copies may be obtained through any Field Office.





Repair Track Maintenance
DB-60 Doc. No.: IP-175
Revision: 07 08/8/2016 - en

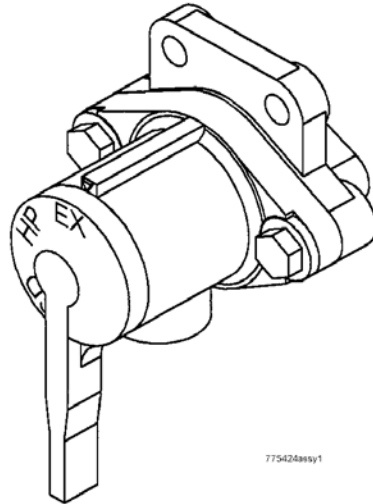

Figure 27: Composite Three Position Retaining Valve

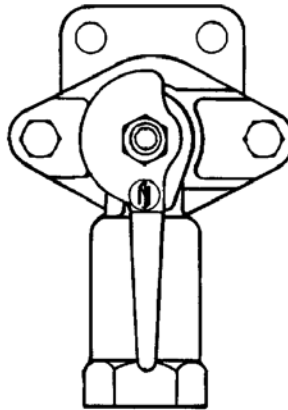
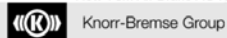

Figure 28: NY-3 Three Position Retaining Valve

Copyright 2016© New York Air Brake AG. All rights reserved, including industrial property rights applications.
New York Air Brake AG retains any power of disposal, such as copying and transferring.





5.10 KRD2A-500AR SLACK ADJUSTER, Fig. 29, 30 and 31

If the results of the air brake testing confirm that the slack adjuster is defective, the following steps are used to replace the slack adjuster.

- 5.10.1 Drain the air out of the auxiliary reservoir, emergency reservoir and brake cylinder. Ensure that all tension is out of the brake rigging before attempting to remove a Slack Adjuster. Follow all safety guidelines for working on or around railroad equipment.
- 5.10.2 Remove the pin attaching the Control Shaft (22) to the Control Lever on the brake rigging.
- 5.10.3 Remove pin connecting the Spindle Clevis (23) from the Fulcrum Lever on the brake rigging.
- 5.10.4 Support the loose end of the Slack Adjuster, and remove the pin connecting the Suspension Clevis (21) to the Cylinder Lever on the brake rigging.
- 5.10.5 Remove the Slack Adjuster unit from the car.

5.10.6 INSTALLATION

- 5.10.6.1 Attach Suspension Clevis (21) to Cylinder Lever of brake rigging using an AAR Type "A" Pin - 1-7/32" dia. X 3-1/2" long.

	<p>CAUTION</p> <p>If machine line becomes visible on the slack adjuster spindle (18), during the following manual adjustment, the slack adjuster spindle (18) must be turned until the machine line is flush with the slack adjuster spindle sleeve (1) plus one half turn in. Otherwise the slack adjuster will be over extended and may not function properly. The approximate length, pin hole to pin hole, will be 81-3/4" +/-1/4".</p>
--	--

5.10.7 ADJUSTMENT

- 5.10.7.1 Adjust length of Slack Adjuster as required by turning Adjuster Spindle (18) using the Spindle Clevis (23), so that the hole in Spindle Clevis (23) lines up with the hole in the fulcrum lever of the brake rigging.
- 5.10.7.2 Once a proper length is acquired, attach Spindle Clevis (23) to Fulcrum Lever of brake rigging using an AAR Type "A" Pin 1-7/32" dia. X 3-1/2" long pin.

	<p>NOTE</p> <p>Control lever must conform to the requirements of AAR Standard S-420, S-421, and S-422.</p>
--	---

- 5.10.7.3 Install clevis of Control Shaft (22) onto Control Lever of the brake rigging using an AAR Type "B" Pin - 1-3/32" dia. X 2-1/2" long.

Copyright 2016© New York Air Brake AG. All rights reserved, including industrial property rights applications.
New York Air Brake AG retains any power of disposal, such as copying and transferring.





NEW YORK AIR BRAKE

Repair Track Maintenance
DB-60 Doc.-No.: IP-175
Revision: 07 08/8/2016 - en

- 5.10.7.4 Adjust sliding Control Rod Head (20) on Control Shaft (22), securing with Locking Bolts (20.1).
Note: If possible, a minimum 1/8" distance from Control Rod Head (20) to barrel face is recommended at set-up.
- 5.10.7.5 Using 50 psi brake cylinder pressure, check piston stroke. A minimum of (2) applications is required to verify piston stroke. (See Section 2.2)
- 5.10.7.6 Setting proper piston stroke. (See dwg. IP-178 & IP-178-1). Per A.A.R. Field Manual Rule 3, proper piston stroke for a 7-5/8" cylinder is 5-1/2" +/- 1/4", for 8-1/2" or 10" cylinder is 7-1/2" +/- 1/4" and for a 12" cylinder is 5-1/2" +/- 1/4".
- 5.10.7.7 Apply and release the brakes using 50 psi brake cylinder pressure, then apply the brakes again. While brakes are applied, measure the piston stroke on the brake cylinder. Release the brakes.
- 5.10.7.8 Adjust the piston stroke by adjusting the length of the Control Shaft (22) via the Control Head (20). Shorten the Control Shaft to increase piston stroke, and lengthen the Control Shaft to decrease piston stroke. The adjustment necessary is a multiple of the car's lever ratio.
- EXAMPLE:* A car with a 2:1 Lever Ratio will need a 1/2" adjustment on the Control Shaft to create a 1" difference on the piston stroke.
- 5.10.7.9 Once proper piston stroke is achieved, weld Control Head (20) to Control Shaft (22) with 3/16" Fillet welds, minimum (2) sides for a minimum total weld length of 2".
- 5.10.8 **TESTING** - After all repairs have been completed, the slack adjuster must be tested per rule 3 of the AAR Field Manual.
- 5.10.9 For reconditioning the slack adjuster, return to New York Air Brake by contacting any Field Office.

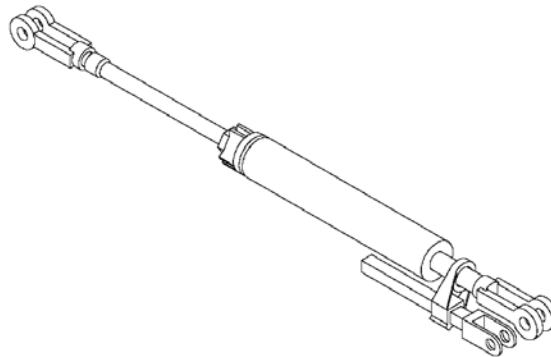

Figure 29: KRD2A-500AR Slack Adjuster

Copyright 2016© New York Air Brake AG. All rights reserved, including industrial property rights applications.
New York Air Brake AG retains any power of disposal, such as copying and transferring.



Knorr-Bremse Group

Page 54 | 77



Repair Track Maintenance
 DB-60 Doc.No.: IP-175
 Revision: 07 08/2016 - en

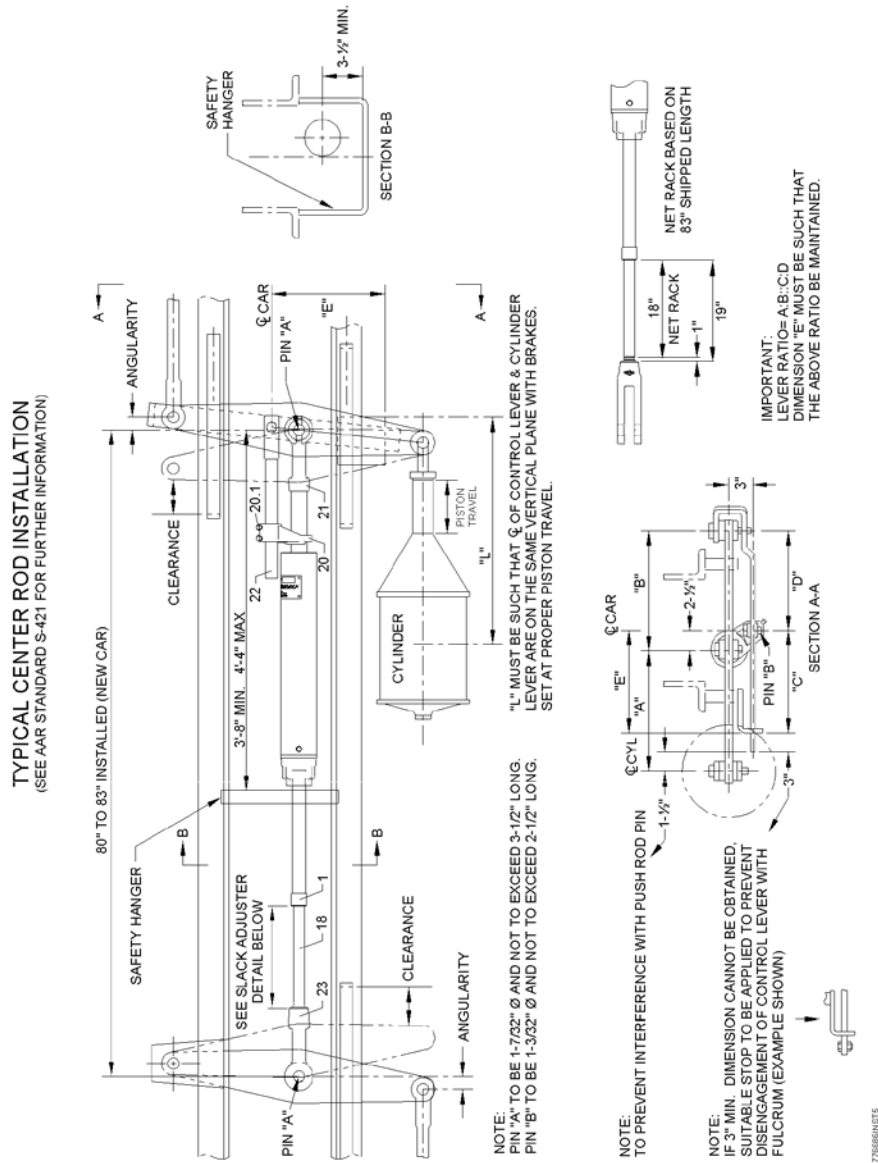
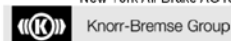

Figure 30: Center Rod Slack Adjuster Installation

Copyright 2016© New York Air Brake AG. All rights reserved, including industrial property rights applications.
 New York Air Brake AG retains any power of disposal, such as copying and transferring.





Repair Track Maintenance
 DB-60 Doc. No.: IP-175
 Revision: 07 08/8/2016 - en

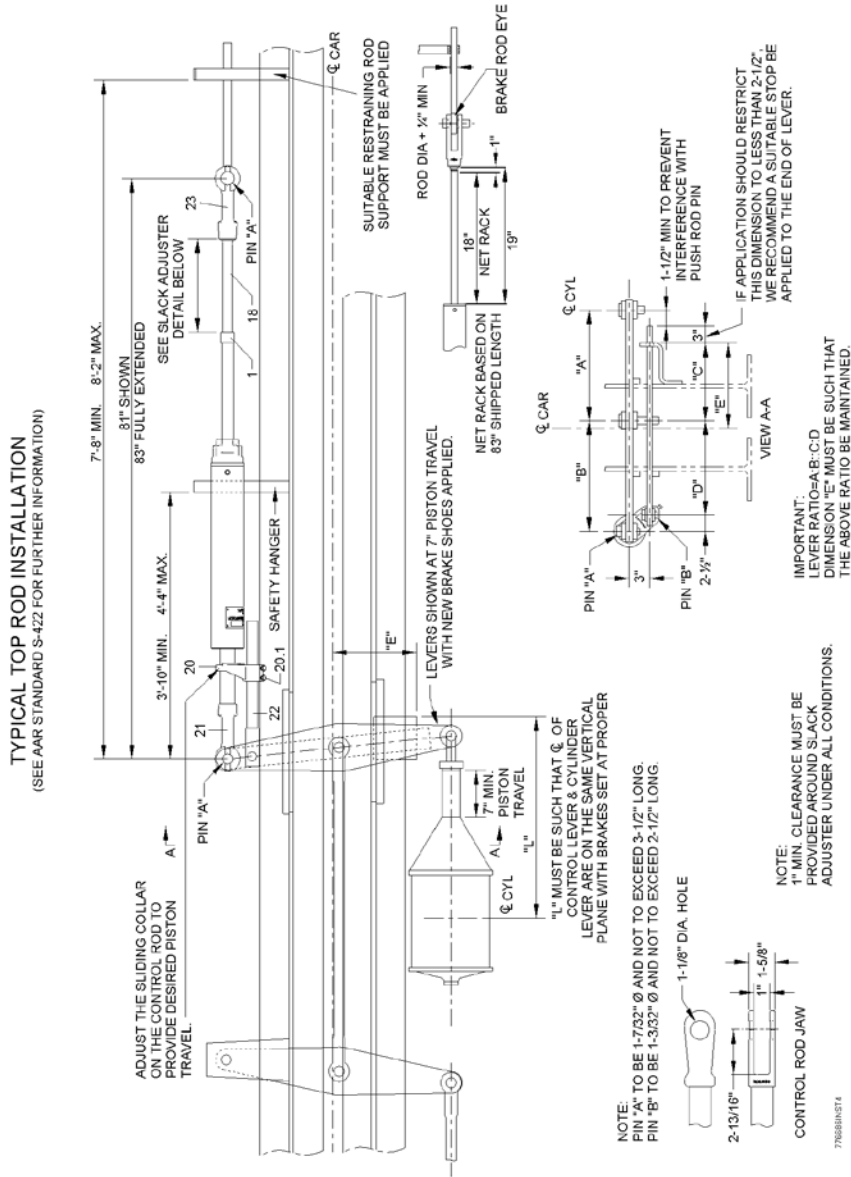
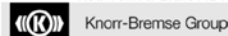

Figure 31: Top Rod Slack Adjuster Installation

Copyright 2016© New York Air Brake AG. All rights reserved, including industrial property rights applications. New York Air Brake AG retains any power of disposal, such as copying and transferring.





5.11 KR-482-E SLACK ADJUSTER, Fig. 32, 33 and 34

If the results of the air brake testing confirm that the slack adjuster is defective, the following steps are used to replace the slack adjuster.

- 5.11.1 Drain the air out of the auxiliary reservoir, emergency reservoir and brake cylinder. Ensure that all tension is out of the brake rigging before attempting to remove a Slack Adjuster. Follow all safety guidelines for working on or around railroad equipment.
- 5.11.2 Remove the pin attaching the Control Rod (22) to the Control Lever on the brake rigging.
- 5.11.3 Remove pin connecting the Front Clevis (23) from the Fulcrum Lever on the brake rigging.
- 5.11.4 Support the loose end of the Slack Adjuster, and remove the pin connecting the Rear Clevis (21) to the Cylinder Lever on the brake rigging.
- 5.11.5 Remove the Slack Adjuster unit from the car.

5.11.6 INSTALLATION

- 5.11.6.1 Attach Rear Clevis (21) to Cylinder Lever of brake rigging using an AAR Type "A" Pin - 1-7/32" dia. X 3-1/2" long.

5.11.7 ADJUSTMENT

- 5.11.7.1 Adjust length of Slack Adjuster as required by turning Adjuster Spindle (18) using the Front Clevis (23), so that the hole in Front Clevis (23) lines up with the hole in the fulcrum lever of the brake rigging.
- 5.11.7.2 Once a proper length is acquired, attach Front Clevis (23) to Fulcrum Lever of brake rigging using an AAR Type "A" Pin 1-7/32" dia. X 3-1/2" long pin.

NOTICE	NOTE Control lever must conform to the requirements of AAR Standard S-420, S-421, and S-422.
---------------	--

- 5.11.7.3 Install clevis of Control Rod (22) onto Control Lever of the brake rigging using an AAR Type "B" Pin - 1-3/32" dia. X 2-1/2" long.
- 5.11.7.4 Adjust sliding Actuation Collar (20) on Control rod (22), securing with Locking Bolt (20.1).
- 5.11.7.5 Using 50 psi brake cylinder pressure, check piston stroke. A minimum of (2) applications is required to verify piston stroke. (See Section 2.2)
- 5.11.7.6 Setting proper piston stroke. (See dwg. IP-178 & IP-178-1). Per A.A.R. Field Manual Rule 3, proper piston stroke for a 7-5/8" cylinder is 5-1/2" +/- 1/4", for 8-1/2" or 10" cylinder is 7-1/2" +/- 1/4" and for a 12" cylinder is 5-1/2" +/- 1/4".

Copyright 2016© New York Air Brake AG. All rights reserved, including industrial property rights applications.
New York Air Brake AG retains any power of disposal, such as copying and transferring.





NEW YORK AIR BRAKE

Repair Track Maintenance
DB-60 Doc.-No.: IP-175
Revision: 07 08/8/2016 - en

- 5.11.7.7 Apply and release the brakes using 50 psi brake cylinder pressure, then apply the brakes again. While brakes are applied, measure the piston stroke on the brake cylinder. Release the brakes.
- 5.11.7.8 Adjust the piston stroke by adjusting the length of the Control Rod (22) via the Actuating Collar (20). Shorten the Control Rod to increase piston stroke, and lengthen the Control Rod to decrease piston stroke. The adjustment necessary is a multiple of the car's lever ratio.
- EXAMPLE:* A car with a 2:1 Lever Ratio will need a 1/2" adjustment on the Control Shaft to create a 1" difference on the piston stroke.
- 5.11.7.9 Once proper piston stroke is achieved, weld Actuating Collar (20) to Control Rod (22) with 3/16" Fillet welds, minimum (2) sides for a minimum total weld length of 2".
- 5.11.8 **TESTING** - After all repairs have been completed, the slack adjuster must be tested per rule 3 of the AAR Field Manual.
- 5.11.9 For reconditioning the slack adjuster, return to New York Air Brake by contacting any Field Office.

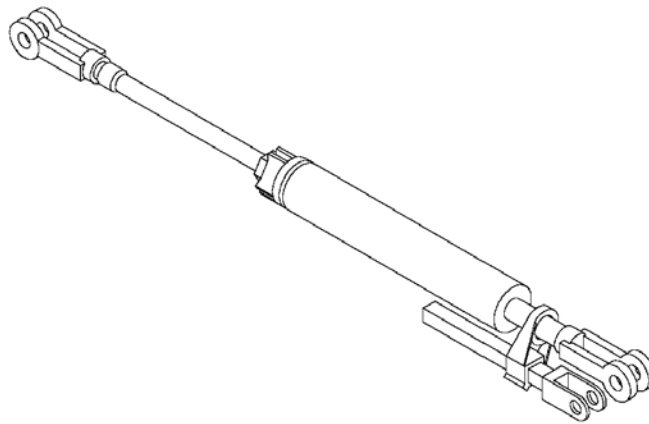

Figure 32: KRD-482-E Slack Adjuster

Copyright 2016© New York Air Brake AG. All rights reserved, including industrial property rights applications.
New York Air Brake AG retains any power of disposal, such as copying and transferring.



Knorr-Bremse Group

Page 58 | 77



Repair Track Maintenance
 DB-60 Doc -No - IP-175
 Revision: 07 08/6/2016 - en

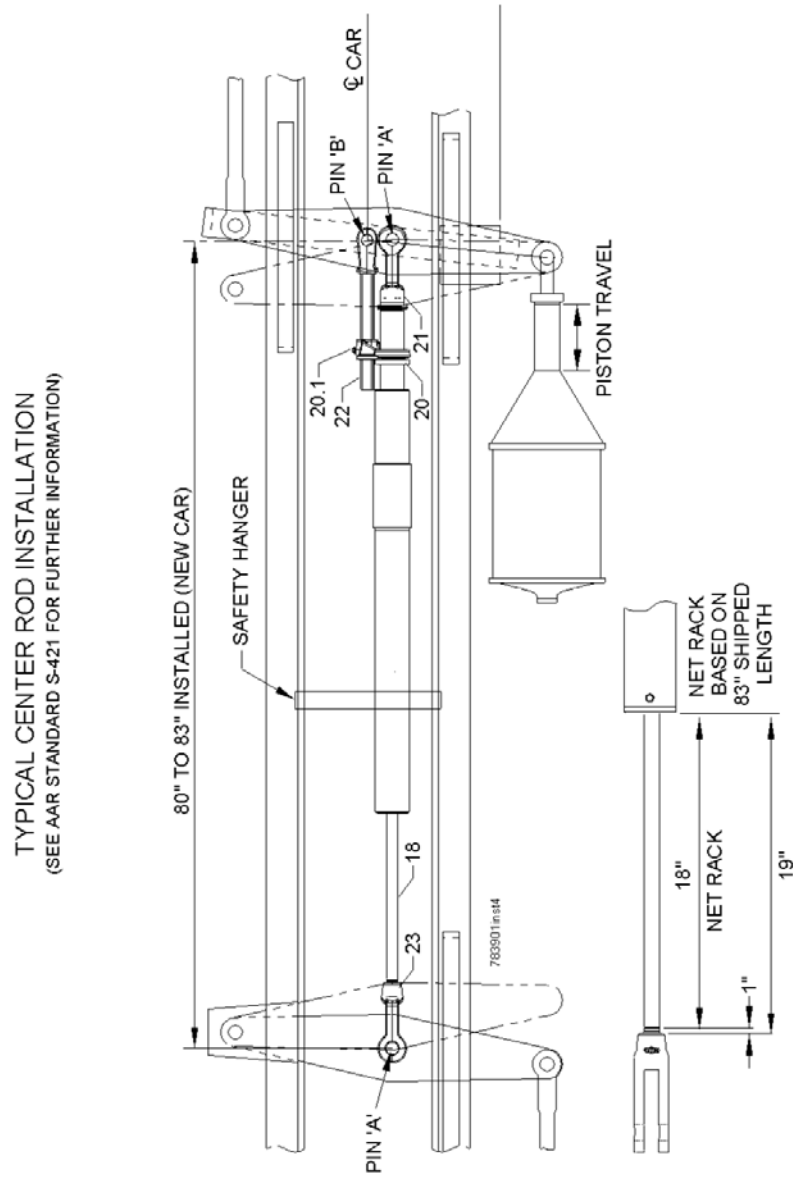
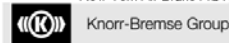

Figure 33: Center Rod Slack Adjuster Installation

Copyright 2016© New York Air Brake AG. All rights reserved, including industrial property rights applications.
 New York Air Brake AG retains any power of disposal, such as copying and transferring.





Repair Track Maintenance
 DB-60 Doc.-No.: IP-175
 Revision: 07 08/8/2016 - en

TYPICAL TOP ROD INSTALLATION
 (SEE AAR STANDARD S-422 FOR FURTHER INFORMATION)

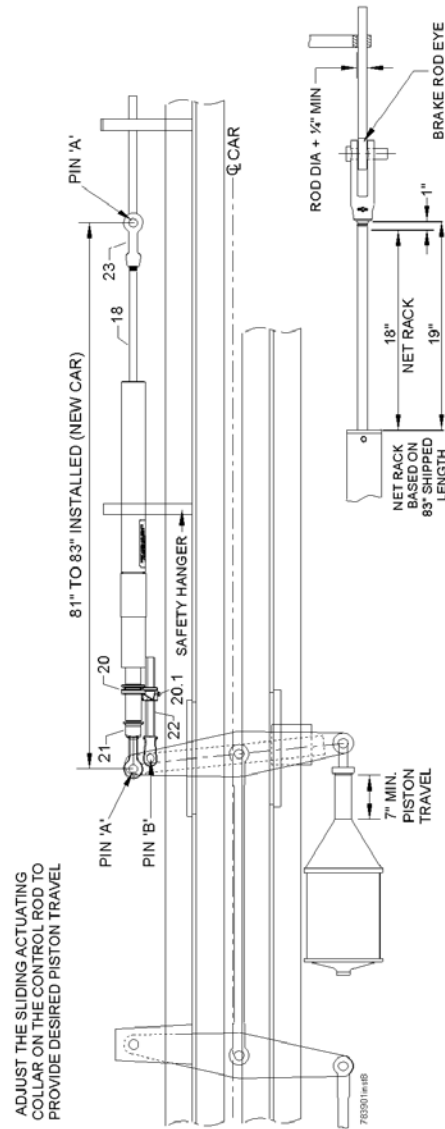
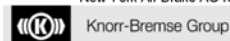

Figure 34: Top Rod Slack Adjuster Installation

Copyright 2016© New York Air Brake AG. All rights reserved, including industrial property rights applications.
 New York Air Brake AG retains any power of disposal, such as copying and transferring.





5.12 EL-60 EMPTY LOAD VALVE PORTION, Fig. 35

If the results of the air brake testing confirm that the empty load portion is defective, the following steps are used to replace the empty load portion.

- 5.12.1 Drain the air out of the auxiliary reservoir, emergency reservoir and brake cylinder.
- 5.12.2 Scrape, wipe and blow off all dirt adjacent to the gaskets between the pipe bracket and the valve portion. Use the air hose, blow off all loose dirt on the valve portion, pipe bracket, truck frame, car under frame, etc., that may otherwise get into the valve portion or bracket when the portion is being removed and cleaned portion applied.
- 5.12.3 Remove the empty load portion and apply protective port covering for shipping.
- 5.12.4 The empty load portion must be carefully handled to avoid entrance of dirt, water or damage to internal parts.
- 5.12.5 When the valve portion is removed and conditions are found in the portion or the pipe bracket evidencing that the car brake equipment has been submerged in water, special additional cleaning operations not regularly performed will be required as directed in Section 7.0.
- 5.12.6 Pipe bracket gasket and filter screens must be replaced with new ones.
- 5.12.7 The protective port coverings must not be removed from the clean empty load portion until prepared to immediately mount the portion on the pipe bracket.
- 5.12.8 With the empty load portion gaskets properly in place on the portion and fully seated. Immediately mount the portion, sliding it slowly and carefully on the studs against the pipe bracket, then, tighten the mounting nuts evenly to 24 +/- 2 ft. lb. dry torque.
- 5.12.9 If the flange connection at the mounting bracket needs to be removed, the ring gaskets need to be replaced, the 3/8" grade 5 bolts tightened to 18 +/- 2 ft lbs dry torque and the 1/2" grade 5 bolts tightened to 40 +/- 5 ft lbs dry torque.

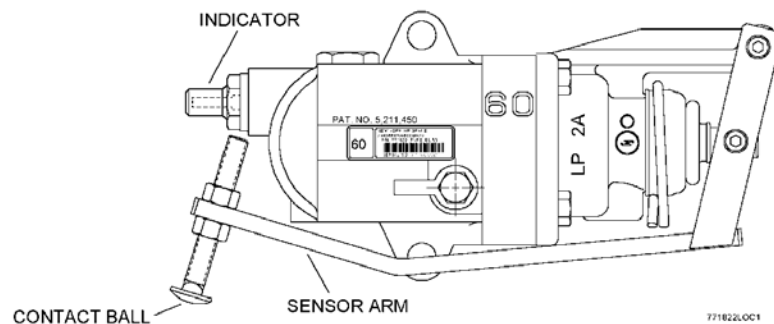

Figure 35: EL-60 Empty Load Valve Portion

Copyright 2016© New York Air Brake AG. All rights reserved, including industrial property rights applications. New York Air Brake AG retains any power of disposal, such as copying and transferring.





NEW YORK AIR BRAKE

Repair Track Maintenance
 DB-60 Doc-No: IP-175
 Revision: 07_08/6/2016 - en

5.12.10 INSPECTION

- 5.12.10.1 Before proceeding with adjustment of the Empty Load equipment the following examination should be performed.
- 5.12.10.2 Ensure that the Sensor Arm is not damaged or bent. Move the arm down manually to confirm appropriate location on the side frame, and check for excessive side play, beyond the effective side frame width. Inspect the integrity of the two-sensor arm securing bolts.
- 5.12.10.3 Inspect the adjusting screw for damage or excessive wear on the contact ball, and that both lock nuts are present.
- 5.12.10.4 Inspect for Sensor Boot damage.
Inspect for Indicator Lens damage.
- 5.12.10.5 Confirm that the Portion is secure (24 +/- 2 ft lb).

5.12.11 ADJUSTMENT

- 5.12.11.1 In order to perform the adjustments, a Freight Single Car Test Device must be connected to the car. For approved Freight Single Car Test Devices and appropriate method of connection to the car, refer to AAR Standard S-486 latest issue.
- 5.12.11.2 **TOOLS REQUIRED:** 9/16" and 3/8" open ended wrenches.

NOTICE	NOTE
	The car must be empty and positioned on straight level track in order to properly set the EL-60 Empty Load Valve.

- 5.12.11.3.1 With the brakes fully released loosen the lock nuts, which secure the sensor arm adjusting screw. Screw the adjusting screw in as far as it will go.
- 5.12.11.3.2 On new cars or on cars with new truck springs, pull the sensor valve arm down as far as it will go and hold it in position. Screw the sensor valve adjusting screw out until it just touches the truck side frame, gently return the sensor valve arm to the release position. Turn the adjusting screw out the number of turns designated in Table 1 below minus four turns. Continue to step 5.12.11.4.
- 5.12.11.3.3 On all other cars pull the sensor arm down as far as it will go and hold it in position. Screw the adjusting screw out until it just touches the truck side frame, gently return the sensor arm to the release position, then screw the adjusting screw out the required complete turns for the valve as designated in the following table in order to remove the slack from the sensor arm.

60% Valve	4 complete turns or (1/4" +/- 1/16")
50% Valve	6 complete turns or (3/8" +/- 1/16")
40% Valve	8 complete turns or (1/2" +/- 1/16")

Table 1

Copyright 2016© New York Air Brake AG. All rights reserved, including industrial property rights applications.
 New York Air Brake AG retains any power of disposal, such as copying and transferring.



Knorr-Bremse Group

Page 62 / 77



5.12.11.3.4 Lock the adjusting screw in place using one lock nut below and one lock nut above the sensor arm. Be careful not to change the setting of the adjusting screw while securing the lock nuts.

5.12.11.3.5 TO CHECK THE SETTING

With a freight single car test device connected to the car, charge BP to 90 psi and install a 1-1/2" block under the sensor arm adjusting screw.

When the flowrator ball drops below the top of the tube, make a 20 to 30-psi brake pipe reduction and note that the Empty Load Indicator is not extended. Recharge BP and remove the block. When the flowrator ball drops below the top of the tube make another 20 to 30 psi brake pipe reduction and note that the indicator is extended, indicating that the system is providing empty car braking. If the indicator is not extended repeat the set-up process steps 5.12.11.3.1 through 5.12.11.3.5. Then proceed to step 5.12.12.

5.12.11.4 If an Empty/Load stencil is applied to the car, it should reflect that no setup block is required or no setup per NYAB service instruction NYS-114 is required.

5.12.12 LEAKAGE

Make sure that there is no leakage from the Vent Strainers, the Indicator Assembly, or the Equalizing Volume Piping.

Leakage from either the Indicator or Equalizing Volume/Piping can only be detected locally and cannot be observed at the Single Car Test Device.

5.12.13 TESTING: After all repairs have been completed, the empty load valve must be tested per rule 3 of the AAR Field Manual.

5.12.14 For reconditioning the EL-60 empty load valve, refer to New York Air Brake repair procedure NYR-303. Copies may be obtained at any Field Office.

5.13 ELRP SENSOR VALVE, Fig 36

If the results of the air brake testing confirm that the sensor portion is defective, the following steps are used to replace the sensor portion.

5.13.1 Drain the air out of the auxiliary reservoir, emergency reservoir and brake cylinder.

5.13.2 Scrape, wipe and blow off all dirt adjacent to the gaskets between the pipe bracket and the sensor portion. Use the air hose, blow off all loose dirt on the sensor portion, pipe bracket, truck frame, car under-frame, etc., that may otherwise get into the sensor portion or bracket when the portion is being removed and cleaned portion applied.

5.13.3 Remove the sensor portion and apply protective port covering for shipping.

5.13.4 The sensor portion must be carefully handled to avoid entrance of dirt, water or damage to internal parts.





- 5.13.5 When the sensor portion is removed and conditions are found in the portion or the pipe bracket evidencing that the car brake equipment has been submerged in water, special additional cleaning operations not regularly performed will be required as directed in section 7.0.
- 5.13.6 Pipe bracket gasket and filter screens must be replaced with new ones.
- 5.13.7 The protective port coverings must be removed from the clean sensor portion until prepared to immediately mount the portion on the pipe bracket.
- 5.13.8 With the sensor portion gaskets properly in place on the portion and fully seated. Immediately mount the portion, sliding it slowly and carefully on the studs against the pipe bracket. Tighten the mounting nuts evenly to 24 +/- 2 ft-lbs dry torque.
- 5.13.9 If the flange connection at the mounting bracket needs to be removed, the ring gaskets need to be replaced and the 3/8" grade 5 bolts tightened to 18 +/- 2 ft lbs dry torque.

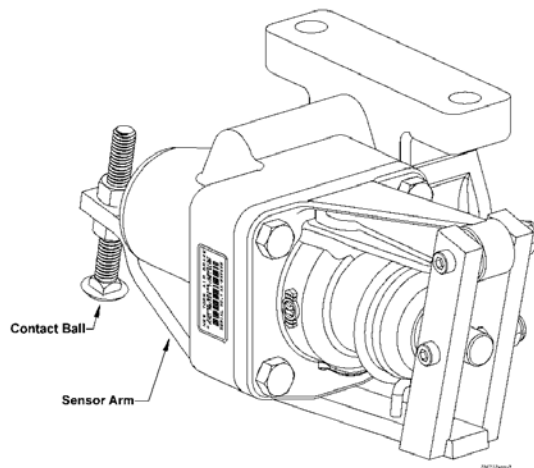

Figure 36: ELRP Sensor Portion

- 5.13.10 **INSPECTION**
- 5.13.10.1 Before proceeding with adjustment of the ELRP equipment the following examination should be performed.
- 5.13.10.2 Ensure that the Sensor Arm is not damaged or bent. Move the arm down manually to confirm appropriate location on the side frame, and check for excessive side play, beyond the effective side frame width. Inspect the integrity of the two-sensor arm securing bolts.

Copyright 2016© New York Air Brake AG. All rights reserved, including industrial property rights applications.
New York Air Brake AG retains any power of disposal, such as copying and transferring.





NEW YORK AIR BRAKE

Repair Track Maintenance
 DB-60 Doc-No: IP-175
 Revision: 07 08/6/2016 - en

- 5.13.10.3 Inspect the adjusting screw for damage or excessive wear on the contact ball, and that both lock nuts are present.
- 5.13.10.4 Inspect for sensor boot damage.
- 5.13.10.5 Confirm that the Portion is secure (24 +/- 2 ft lb).

5.13.11 ADJUSTMENT

- 5.13.11.1 In order to perform the adjustments, a Freight Single Car Test Device must be connected to the car. For approved Freight Single Car Test Devices and appropriate method of connection to the car, refer to AAR Standard S-486 latest issue.
- 5.13.11.2 TOOLS REQUIRED: 9/16" and 3/8" open ended wrenches.

NOTICE **NOTE**
 The car must be empty and positioned on straight level track in order to properly set the ELRP sensor valve.

- 5.13.11.3 With the brakes fully released loosen the lock nuts, which secure the sensor valve adjusting screw. Screw the adjusting screw in as far as it will go.
- 5.13.11.4 On new cars or on cars with new truck springs, pull the sensor valve arm down as far as it will go and hold it in position. Screw the sensor valve adjusting screw out until it just touches the truck side frame, gently return the sensor valve arm to the release position. Turn the adjusting screw out the number of turns designated in Table 2 below minus four turns. Continue to Step 5.13.11.6.
- 5.13.11.5 On all other cars pull the sensor valve arm down as far as it will go and hold it in position. Screw the sensor valve adjusting screw out until it just touches the truck side frame, gently return the sensor valve arm to the release position, then screw the adjusting screw out the required complete turns for the valve in Table 2 below in order to remove the slack from the sensor arm.

60% Valve	4 complete turns or (1/4" +/- 1/16")
50% Valve	6 complete turns or (3/8" +/- 1/16")
40% Valve	8 complete turns or (1/2" +/- 1/16")

Table 2

- 5.13.11.6 Lock the adjusting screw in place using one lock nut below and one lock nut above the sensor valve arm. Be careful not to change the setting of the adjusting screw while securing the lock nuts.

Copyright 2016© New York Air Brake AG. All rights reserved, including industrial property rights applications.
 New York Air Brake AG retains any power of disposal, such as copying and transferring.



Knorr-Bremse Group

Page 65 / 77



5.13.11.7 TO CHECK THE SETTING

With a freight single car test device connected to the car, charge BP to 90 psi and install a 1-1/2" block under the sensor arm adjusting screw.

When the flowrator ball drops below the top of the tube, make a 20 to 30-psi brake pipe reduction and note that the Empty Load Indicator on the ELRP Load Proportional Valve is not extended. Recharge BP and remove the block. When the flowrator ball drops below the top of the tube make another 20 to 30 psi brake pipe reduction and note that the indicator on the ELRP Load Proportional Valve is extended, indicating that the system is providing empty car braking. If the indicator on the ELRP Load Proportional Valve is not extended repeat the set-up process steps 5.13.11.3 through 5.13.11.7. Then proceed to step 5.13.11.8.

5.13.11.8 Move device handle to position 1 and recharge equipment.

5.13.12 **TESTING:** After all repairs have been completed, the Sensor portion must be tested per rule 3 of the AAR Field Manual.

5.13.13 For reconditioning the ELRP Sensor valve, refer to New York Air Brake repair procedure NYR-441. Copies may be obtained from any field office.

5.14 ELRP - LOAD PROPORTIONAL VALVE, Fig 37

If the results of the air brake testing confirm that the proportional valve portion is defective, the following steps are used to replace the proportional valve portion.

5.14.1 Drain the air out of the auxiliary reservoir, emergency reservoir and brake cylinder.

5.14.2 Scrape, wipe and blow off all dirt adjacent to the gaskets between the pipe bracket and the proportional valve portion. Use the air hose, blow off all loose dirt on the proportional valve portion, pipe bracket, truck frame, car under-frame, etc., that may otherwise get into the proportional valve portion or bracket when the portion is being removed and cleaned portion applied.

5.14.3 Remove the proportional valve portion and apply protective port covering for shipping.

5.14.4 The proportional valve portion must be carefully handled to avoid entrance of dirt, water or damage to internal parts.

5.14.5 When the proportional valve portion is removed and conditions are found in the portion or the pipe bracket evidencing that the car brake equipment has been submerged in water, special additional cleaning operations not regularly performed will be required as directed in Section 7.0.

5.14.6 Pipe bracket gasket and filter screens must be replaced with new ones.

5.14.7 The protective port coverings must not be removed from the clean proportional valve portion until prepared to immediately mount the portion on the pipe bracket.

Copyright 2016© New York Air Brake AG. All rights reserved, including industrial property rights applications.
New York Air Brake AG retains any power of disposal, such as copying and transferring.





NEW YORK AIR BRAKE

Repair Track Maintenance
DB-60 Doc. No.: IP-175
Revision: 07 08/8/2016 - en

- 5.14.8 With the proportional valve portion gaskets properly in place on the portion and fully seated. Immediately mount the portion, sliding it slowly and carefully on the studs against the pipe bracket, then, tighten the mounting nuts evenly to 24 +/- 2 ft. lb. dry torque.
- 5.14.9 If the flange connections at the mounting bracket needs to be removed, the ring gaskets need to be replaced, the 3/8" grade 5 bolts tightened to 18 +/- 2 lbs dry torque and the 1/2" grade 5 bolts tightened to 40 +/- 5 lbs dry torque.
- 5.14.10 Inspect the Indicator lens to ensure that it is not damaged.
- 5.14.11 **TESTING:** After all repairs have been completed, the Load Proportional Valve must be tested per rule 3 of the AAR Field Manual.
- 5.14.12 For reconditioning the ELRP Load Proportional Valve, refer to New York Air Brake repair procedure NYR-442. Copies may be obtained through any field office.

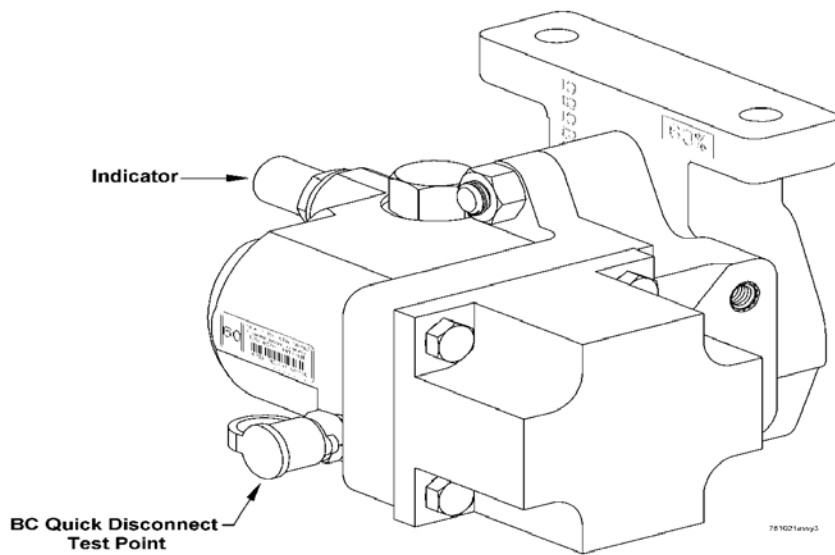

Figure 37: ELRP Proportional Valve Portion

Copyright 2016© New York Air Brake AG. All rights reserved, including industrial property rights applications.
New York Air Brake AG retains any power of disposal, such as copying and transferring.



Knorr-Bremse Group

Page 67 | 77



5.15 S-1 LOAD SENSOR VALVE, Fig. 38

If the results of the air brake testing confirm that the sensor valve portion is defective, the following steps are used to replace the sensor valve portion.

- 5.15.1 Drain the air out of the auxiliary reservoir, emergency reservoir and brake cylinder.
- 5.15.2 Scrape, wipe and blow off all dirt adjacent to the gaskets between the pipe bracket and the sensor valve portion. Use the air hose, blow off all loose dirt on the sensor valve portion, pipe bracket, truck frame, car under-frame, etc., that may otherwise get into the sensor valve portion or bracket when the portion is being removed and cleaned portion applied.
- 5.15.3 Remove the sensor valve portion and apply protective port covering for shipping.
- 5.15.4 The sensor valve portion must be carefully handled to avoid entrance of dirt, water or damage to internal parts.
- 5.15.5 When the sensor valve portion is removed and conditions are found in the portion or the pipe bracket evidencing that the car brake equipment has been submerged in water, special additional cleaning operations not regularly performed will be required as directed in Section 7.0.
- 5.15.6 Pipe bracket gasket and filter screens must be replaced with new ones.
- 5.15.7 The protective port coverings must not be removed from the clean sensor valve portion until prepared to immediately mount the portion on the pipe bracket.
- 5.15.8 With the sensor valve portion gaskets properly in place on the portion and fully seated. Immediately mount the portion, sliding it slowly and carefully on the studs against the pipe bracket, then, tighten the mounting nuts evenly to 35 +/- 5 ft. lb. dry torque.
- 5.15.9 If the flange connections at the mounting bracket needs to be removed, the ring gaskets need to be replaced and the 3/8" grade 5 bolts tightened to 18 +/- 2 ft lbs dry torque.

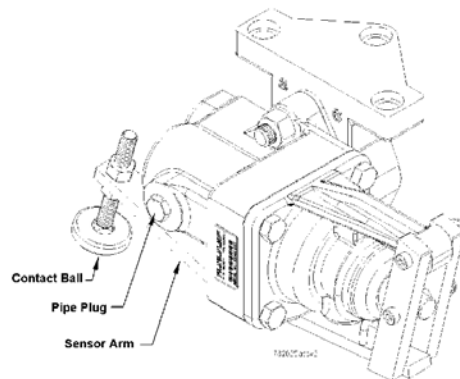

Figure 38: S-1 Sensor Valve

Copyright 2016© New York Air Brake AG. All rights reserved, including industrial property rights applications.
New York Air Brake AG retains any power of disposal, such as copying and transferring.





NEW YORK AIR BRAKE

Repair Track Maintenance
DB-60 Doc-No: IP-175
Revision: 07 09/6/2016 - en

5.15.10 INSPECTION

- 5.15.10.1 Before proceeding with adjustment of the S-1 equipment the following examination should be performed.
- 5.15.10.2 Ensure that the Sensor Arm is not damaged or bent. Move the arm down manually to confirm appropriate location on the side frame, and check for excessive side play, beyond the effective side frame width. Inspect the integrity of the two-sensor arm securing bolts.
- 5.15.10.3 Inspect the adjusting screw for damage or excessive wear on the contact ball, and that both lock nuts are present.
- 5.15.10.4 Inspect for Sensor Boot damage.
- 5.15.10.5 Confirm that the Portion is secure (35 +/- 5 ft lb).

5.15.11 ADJUSTMENT

- 5.15.11.1 In order to perform the adjustments, a Freight Single Car Test Device must be connected to the car. For approved Freight Single Car Test Devices and appropriate method of connection to the car, refer to AAR Standard S-486 latest issue.
- 5.15.11.2 TOOLS REQUIRED: 9/16" and 3/8" open ended wrenches.
- 5.15.11.3 Remove the pipe plug and screw the contact ball outward to the extreme distance.
- 5.15.11.4 Place adjusting block on contact plate directly below contact ball. (Adjusting block thickness to be equal to 1/5 the spring deflection between light and loaded car. If the empty to load truck spring deflection is not known, a 7/16" block having a tolerance of minus 1/32" should be utilized).
- 5.15.11.5 With the brake system charged to 90 psi, move the device handle to position 5 and reduce brake pipe pressure 20 psi then slowly return handle to position 3. Adjust contact ball until light blow of air is obtained at pipe plug hole. Lock contact ball in place.
- 5.15.11.6 Apply Loctite #592 pipe sealant to the pipe plug and tighten it into the body then remove adjusting block. Coat pipe plug with soap suds to detect leakage. No leakage is permitted.
- 5.15.11.7 Move device handle to position 1 and recharge equipment.
- 5.15.12 **TESTING:** After all repairs have been completed, the Sensor Valve must be tested per rule 3 of the AAR Field Manual.
- 5.15.13 For reconditioning the S-1 Load Sensor Valve, refer to New York Air Brake repair procedure NYR-459. Copies may be obtained through any field office.

Copyright 2016© New York Air Brake AG. All rights reserved, including industrial property rights applications.
New York Air Brake AG retains any power of disposal, such as copying and transferring.



Knorr-Bremse Group

Page 69 / 77



5.16 P-1 LOAD PROPORTIONAL VALVE, Fig 39

If the results of the air brake testing confirm that the proportional valve portion is defective, the following steps are used to replace the proportional valve portion.

- 5.16.1 Drain the air out of the auxiliary reservoir, emergency reservoir and brake cylinder.
- 5.16.2 Scrape, wipe and blow off all dirt adjacent to the gaskets between the pipe bracket and the proportional valve portion. Use the air hose, blow off all loose dirt on the proportional valve portion, pipe bracket, truck frame, car under-frame, etc., that may otherwise get into the proportional valve portion or bracket when the portion is being removed and cleaned portion applied.
- 5.16.3 Remove the proportional valve portion and apply protective port covering for shipping.
- 5.16.4 The proportional valve portion must be carefully handled to avoid entrance of dirt, water or damage to internal parts.
- 5.16.5 When the proportional valve portion is removed and conditions are found in the portion or the pipe bracket evidencing that the car brake equipment has been submerged in water, special additional cleaning operations not regularly performed will be required as directed in Section 7.0.
- 5.16.6 Pipe bracket gasket and filter screens must be replaced with new ones.
- 5.16.7 The protective port coverings must not be removed from the clean proportional valve portion until prepared to immediately mount the portion on the pipe bracket.
- 5.16.8 With the proportional valve portion gaskets properly in place on the portion and fully seated. Immediately mount the portion, sliding it slowly and carefully on the studs against the pipe bracket, then, tighten the mounting nuts evenly to 35 +/- 5 ft. lb. dry torque.
- 5.16.8 Inspect the Indicator lens to ensure that it is not damaged.
- 5.16.10 If the flange connections at the mounting bracket needs to be removed, the ring gaskets need to be replaced and the 3/8" grade 5 bolts tightened to 18 +/- 2 ft lbs dry torque and the 1/2" grade 5 bolts tightened to 40 +/- 5 ft lbs dry torque.
- 5.16.11 **TESTING:** After all repairs have been completed, the Proportional Valve must be tested per rule 3 of the AAR Field Manual.
- 5.16.12 For reconditioning the P-1 Load Proportional Valve, refer to New York Air Brake repair procedure NYR-460. Copies may be obtained through any field office.





Repair Track Maintenance
DB-60 Doc.-No.: IP-175
Revision: 07 08/8/2016 - en

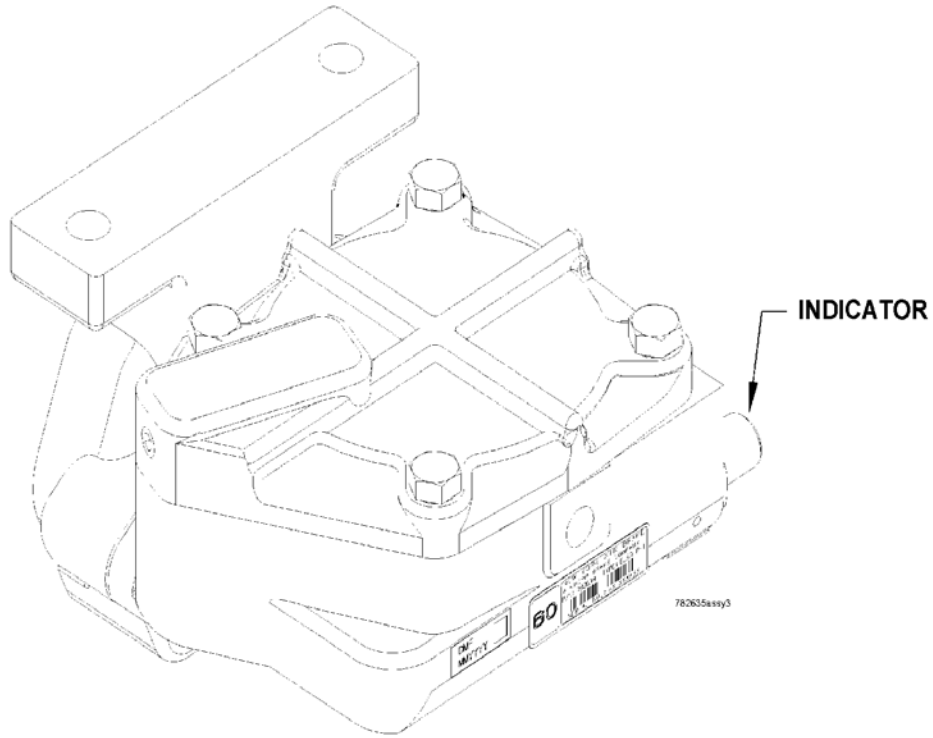
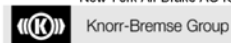

Figure 39: P-1 Load Proportional Valve

Copyright 2016© New York Air Brake AG. All rights reserved, including industrial property rights applications.
New York Air Brake AG retains any power of disposal, such as copying and transferring.





6.0 RUBBER PARTS, SHELF LIFE AND STORAGE

- 6.1 New rubber parts such as gaskets, O-rings, rubber seated check valves, seals, diaphragms, etc., must not be applied if over five years old.
- 6.2 To determine shelf life, new rubber repair kits must be dated with the oldest date (half-year) of rubber components contained within the kit.
- 6.3 The storage area of rubber parts should be cool, dark, and free from dampness and mildew. Since most rubber products can be affected by ozone, they must not be stored near electrical equipment that may generate ozone.

7.0 PROCEDURE FOR CLEANING STANDARD FREIGHT BRAKES THAT HAVE BEEN SUBMERGED

- 7.1 Remove all associated piping from the control valve pipe bracket, the auxiliary air device pipe brackets, reservoirs, brake cylinder and retaining valve and remove the pipe brackets and the reservoirs from the car.
- 7.2 Remove and clean the emergency and auxiliary reservoir pipe strainers.
- 7.3 Remove the strainer nut and strainer from the pipe bracket (See fig. 41 & 43). On single sided pipe brackets, also remove the choke in the service portion face (See fig. 43).
- 7.4 Loosen any foreign matter in the pipe bracket passages, using suitably shaped scrapers, and then in a blow both or equivalent protective enclosure, blow out all passages with compressed air of at least 110 psi. Also in a protective enclosure, wash out the passages with high pressure water, using a small nozzle which will enter the ports and then dry all ports and passages thoroughly by blowing air through them with the pipe bracket placed in various positions.
- 7.5 The quick action chamber port (See Fig. 41 and 43) must be thoroughly blown with air pressure to insure the removal of all water and dirt from the quick action chamber volume in the bracket.
- 7.6 Clean all reservoirs and volumes by washing out with high pressure water using a suitable nozzle, then allow all water to drain until dry.
- 7.7 Install a new strainer and strainer nut on single sided pipe brackets, and also reinstall the choke in the service portion face.
- 7.8 Clean the inside of all pipes by first hammering, then wash and blow them out with air pressure.
- 7.9 Apply the pipe brackets and reservoirs to the car. Replace the auxiliary and emergency reservoir pipe strainers at the pipe bracket. Replace the ring gaskets at the flange connection. Coat the cap screw threads with grease (AAR Spec. M-914), and reconnect all pipes. Torque the flange pipe connection cap screws per the following chart:





Repair Track Maintenance
 DB-60 Doc-No: IP-175
 Revision: 07_09/6/2016 - en

	Torque Values for Grade 5 Bolts in ft-lbs	
	3/8"	1/2"
On Aluminum Pipe Bracket	18 +/- 2	40 +/- 5
On Cast Iron Pipe Bracket	22 +/- 4	55 +/- 5
On Aux/Emergency Reservoir	----	40 +/- 5

Torque the pipe bracket to car frame mounting 5/8" grade 5 bolts to 150 +/- 5 ft lbs dry torque.

- 7.10 After all repairs have been completed, the entire air brake equipment must be tested as required by the current issue of AAR Standard S-486, Code of Air Brake System Tests for Freight Equipment.

Copyright 2016© New York Air Brake AG. All rights reserved, including industrial property rights applications.
 New York Air Brake AG retains any power of disposal, such as copying and transferring.



Knorr-Bremse Group



Repair Track Maintenance
DB-60 Doc.-No.: IP-175
Revision: 07 08/8/2016 - en

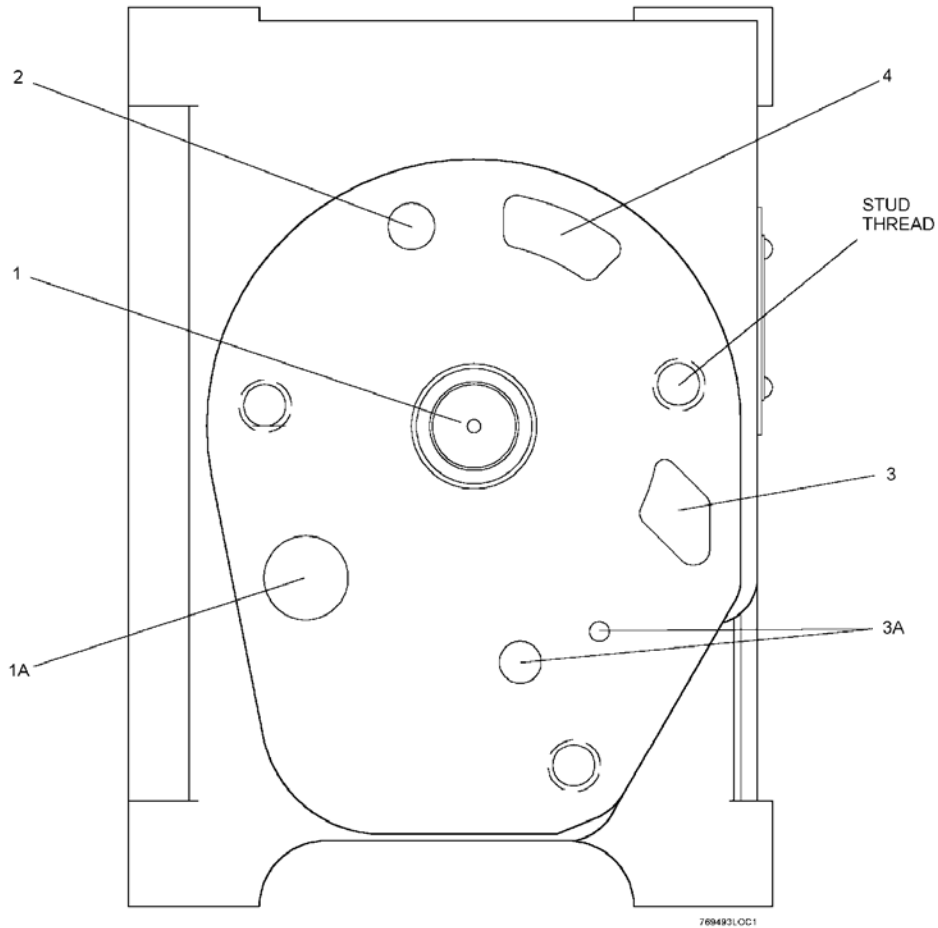

- 1,1A Brake Pipe
- 2 Emergency Reservoir
- 3,3A Brake Cylinder
- 4 Quick Action Chamber

Figure 40: Port Identification Standard Pipe Bracket (Emergency Portion Face)

Copyright 2016© New York Air Brake AG. All rights reserved, including industrial property rights applications.
New York Air Brake AG retains any power of disposal, such as copying and transferring.



Knorr-Bremse Group

Page 74 | 77



Repair Track Maintenance
DB-60 Doc.-No.: IP-175
Revision: 07 08/8/2016 - en

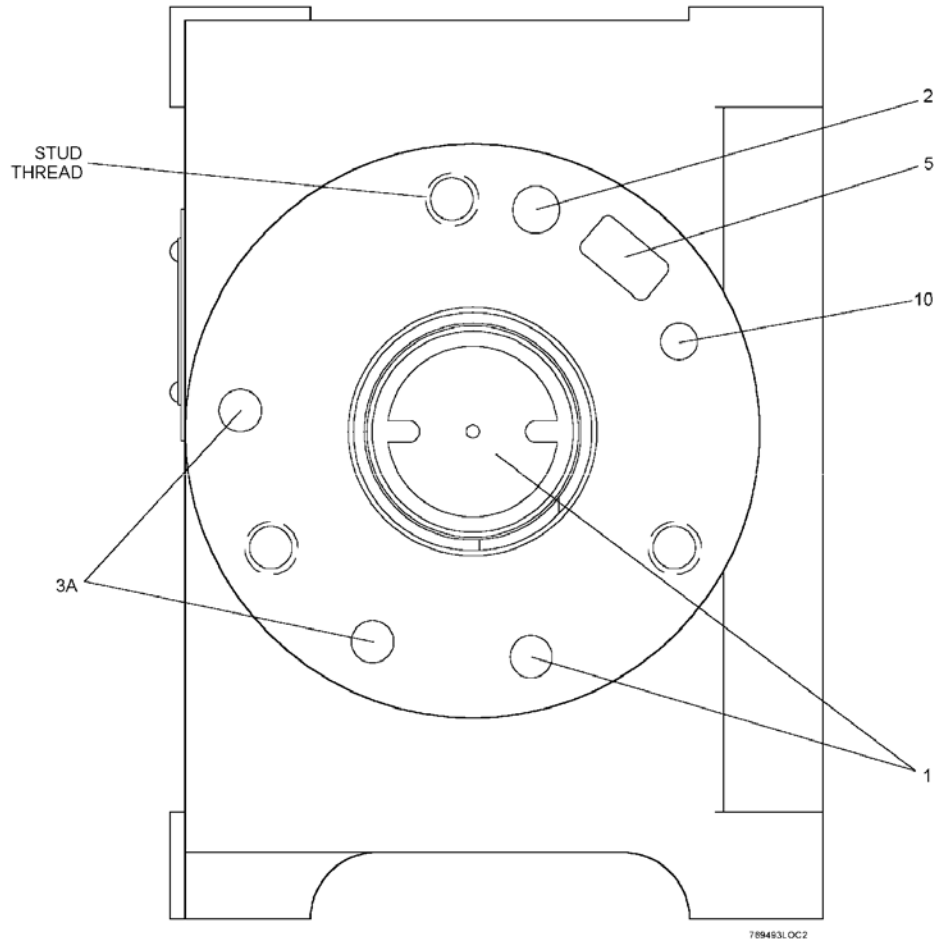

- 1,1A Brake Pipe
- 2 Emergency Reservoir
- 3,3A Brake Cylinder
- 5 Auxiliary Reservoir
- 10 Retaining Pipe

Figure 41: Port Identification Standard Pipe Bracket (Service Portion Face)

Copyright 2016© New York Air Brake AG. All rights reserved, including industrial property rights applications.
New York Air Brake AG retains any power of disposal, such as copying and transferring.



Knorr-Bremse Group

Page 75 | 77



Repair Track Maintenance
 DB-60 Doc.-No.: IP-175
 Revision: 07 08/8/2016 - en

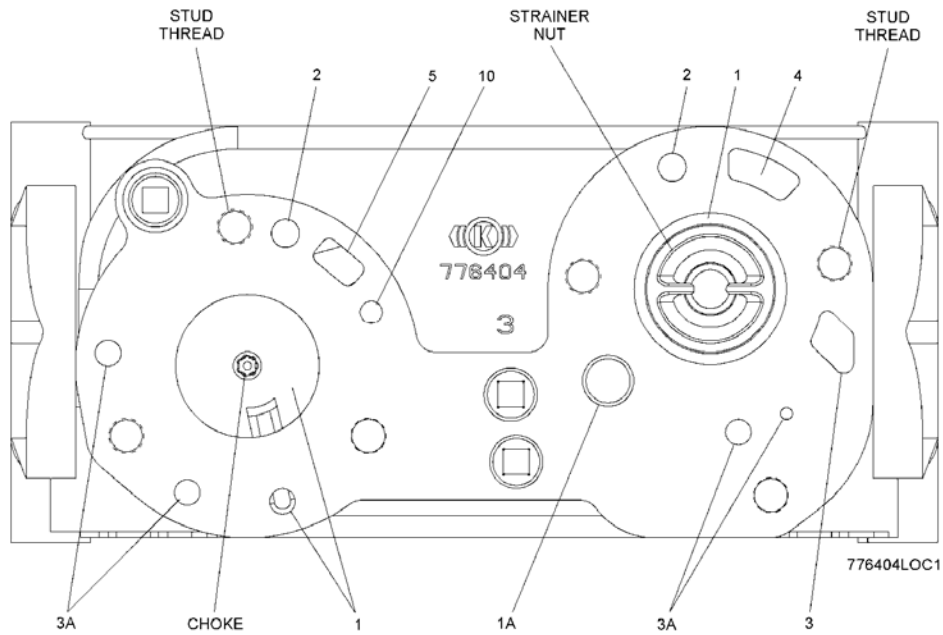

- 1,1A Brake Pipe
- 2 Emergency Reservoir
- 3,3A Brake Cylinder
- 4 Quick Action Chamber
- 5 Auxiliary Reservoir
- 10 Retaining Pipe

Figure 42: Port Identification Single Sided Pipe Bracket (Portion Face)

Copyright 2016© New York Air Brake AG. All rights reserved, including industrial property rights applications.
 New York Air Brake AG retains any power of disposal, such as copying and transferring.

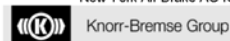



Repair Track Maintenance
DB-60 Doc.-No.: IP-175
Revision: 07 08/8/2016 - en

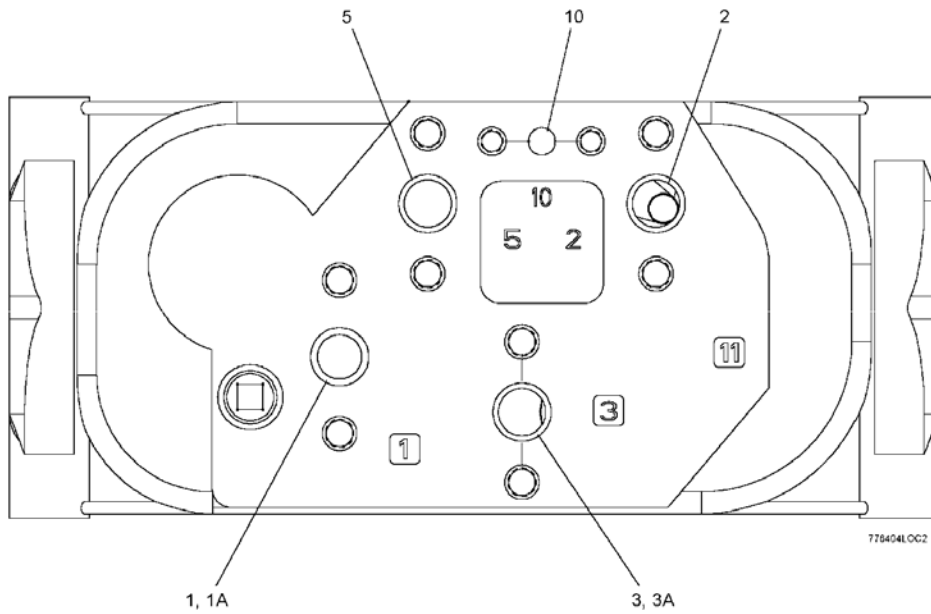

- 1,1A Brake Pipe
- 2 Emergency Reservoir
- 3,3A Brake Cylinder
- 5 Auxiliary Reservoir
- 10 Retaining Pipe

Figure 43: Port Identification Single Sided Pipe Bracket (Pipe Face)

Copyright 2016© New York Air Brake AG. All rights reserved, including industrial property rights applications.
New York Air Brake AG retains any power of disposal, such as copying and transferring.

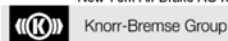

C.2 Maintenance Specification, DB-10C Service Portion, P/N 790586 and
789870RC, NYR-481 Rev 02 09-18-2017-en

Rail Vehicle Systems

.....
.....
NYR-481

Rev 02 9-18-2017 - en
.....

.....
Maintenance Specification

DB-10C[®] Service Portion
P/N 790586 and 789870RC

NEW YORK AIR BRAKE 



Maintenance Specification
DB-10C Doc.No.: NYR-481
Revision: 02 9/18/17 - en

Contact Address

New York Air Brake
748 Starbuck Avenue
Watertown, NY 13601
USA
Phone: +1 315 786 5200
Fax: +1 315 786 5676
www.nyab.com

Copyright 2017© New York Air Brake. All rights reserved, including industrial property rights applications.
New York Air Brake retains any power of disposal, such as copying and transferring.





Maintenance Specification
 DB-10C Doc.No.: NYR-481
 Revision: 02 9/18/17 - en

Revision History

Rev	Date	Name	Para	Description of change
01	8/26/15		All	Original Issue
02	9/18/17		All	Added instructions for cast iron version. Removed references to 100% spring replacement.
			6.4,8.3.2,11.1	Added information for CID Tag/Label.

The original document was issued in English language.

Copyright 2017© New York Air Brake. All rights reserved, including industrial property rights applications.
 New York Air Brake retains any power of disposal, such as copying and transferring.



Knorr-Bremse Group



Maintenance Specification	
DB-10C	Doc.-No.: NYR-481
	Revision: 02 9/18/17 - en

Table of Contents

1	GENERAL INFORMATION	7
1.1	Introduction	7
1.2	Technical Changes	7
1.3	Target Group for this Document	7
1.4	Referenced Documents	8
1.5	Danger, Warning, Caution, and Note (Notice) Messages	8
2	PRODUCT IDENTIFICATION	10
2.1	Serial Prefix Identification	10
2.2	Product Structure	14
3	SAFETY AWARENESS	15
3.1	General Safety Awareness	15
4	TOOLS REQUIRED	16
4.1	Standard Tools	16
4.2	Special Tools	16
5	ADHESIVES, LUBRICANTS, SEALANTS, AND SOLVENTS	17
5.1	Lubricants	17
5.2	Sealants	17
6	DISASSEMBLY	18
6.1	Cleaning	18
6.2	General Requirements	19
6.3	Disassembly of DB-10C Service Portion	20
6.4	Disassembly of DB-10C Release Valve	27
7	CLEANING, INSPECTING AND REPAIRING	33
7.1	Cleaning	33
7.2	Inspecting	34
7.3	Springs	36
7.4	Chokes	37
7.5	Rubber Parts	38
7.6	Filters and Accessory Parts	39

Copyright 2017© New York Air Brake. All rights reserved, including industrial property rights applications.
 New York Air Brake retains any power of disposal, such as copying and transferring.



Knorr-Bremse Group

Page 4 / 73



Maintenance Specification

DB-10C	Doc.-No.: NYR-481
	Revision: 02 9/18/17 - en

8 LUBRICATING AND REASSEMBLY	40
8.1 Lubrication	40
8.2 Torque Requirements	41
8.3 Assembly of DB-10C Service Portion	42
9 TESTING	53
10 MATERIAL HANDLING	53
11 SUPPORT INFORMATION	57
11.1 DB-10C Service Portion Parts	57
11.2 Special Tools - Drawings	68
11.3 Abbreviations and Acronyms	73

Copyright 2017© New York Air Brake. All rights reserved, including industrial property rights applications.
New York Air Brake retains any power of disposal, such as copying and transferring.





Maintenance Specification	
DB-10C	Doc.No.: NYR-481
	Revision: 02 9/18/17 - en

List of Figures

Figure 2-1 DB-60 Control Valve Operating Portions and Double-Sided Pipe Bracket 11

Figure 2-2 DB-60L Control Valve Operating Portions and Double-Sided Pipe Bracket 12

Figure 6-1 Removal and Installation Instructions for KNORR K-Rings (outer lip seal)..... 29

Figure 6-2 DB-10C Service Portion Basic Valve (Assembly View)..... 30

Figure 6-3 DB-10C Service Portion Basic Valve (Assembly View)..... 31

Figure 6-4 Release Valve (Assembly View)..... 32

Figure 7-1 Threaded Bushing..... 34

Figure 7-2 Stem 35

Figure 7-3 Balancing Piston 35

Figure 8-1 Piston Assembly 49

Figure 8-2 Bushing with valve seat (Item 13)..... 50

Figure 8-3 Threaded Bushing (item 14) starting at S/N F0-XXXXX..... 51

Figure 10-1 Examples of Valve Portion Stenciling with Required Information 54

Figure 10-2 DB-10C Service Portion with Shipping Parts (Installed)..... 55

Figure 10-3 Shipping Parts..... 56

Figure 11-1 DB-10C Service Portion (Exploded View) 57

Figure 11-2 DB-10C Housing Assembly (Exploded View) 60

Figure 11-3 DB-10C Filler Piece Assembly (Exploded View) 62

Figure 11-4 DB-10C Release Valve (Exploded View)..... 65

Figure 11-5 Quick Service Valve Removal Tool (P/N 772615)..... 68

Figure 11-6 Quick Service Inlet Valve Positioning Tool (P/N 772616)..... 68

Figure 11-7 Special Hand Drive Pin (P/N 772617) 69

Figure 11-8 Retaining Clamp (P/N 772618)..... 69

Figure 11-9 Guide Pin (P/N 772620)..... 70

Figure 11-10 Bushing Extractor (P/N 772624) 70

Figure 11-11 Retaining Ring Positioning Tool (P/N 772625) 70

Figure 11-12 K-Ring Positioning Tool (P/N 772626)..... 71

Figure 11-13 Thin Wall Type Mandrel (P/N 772628) 71

Figure 11-14 12mm Bore Gage (P/N 790505)..... 72

Figure 11-15 17mm Bore Gage (P/N 790506)..... 72

List of Tables

Table 1-1 Referenced Documents.....10

Table 7-1 Spring Identification.....36

Table 7-2 Choke Identification.....38

Table 8-1 Torque Requirements.....41

Copyright 2017© New York Air Brake. All rights reserved, including industrial property rights applications.
 New York Air Brake retains any power of disposal, such as copying and transferring.

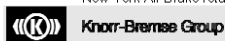



Maintenance Specification	
DB-10C	Doc.-No.: NYR-481
	Revision: 02 9/18/17 - en

1 GENERAL INFORMATION

1.1 Introduction

This description contains particulars specific to the DB-10C[®] Service Portions P/N 790586 (Aluminum) and 789870RC (Cast Iron). This document defines the various procedures and information required to disassemble, clean, inspect, and re-assemble the Service Portions.

	DANGER PLEASE READ THIS DOCUMENT CAREFULLY FROM START TO FINISH ENSURING THE SAFETY OF OPERATION AND TO AVOID PERSONAL INJURIES AND DAMAGE TO EQUIPMENT.
--	--

1.2 Technical Changes

NYAB reserves the right to change the equipment or this document at any time without giving special notice.

1.3 Target Group for this Document

This document is intended for use by trained service technicians who:

- have the skill, experience, safety awareness and professional ability to remove and install the equipment, to inspect, maintain and debug the equipment,
- have read and understood this document from start to finish, and
- are familiar with the safety codes and accident prevention regulations for these activities.

	NOTE This document will be useful to other target groups as well, e.g. project engineers. However, it does not claim to provide complete information for such target groups.
--	---

Copyright 2017© New York Air Brake. All rights reserved, including industrial property rights applications.
New York Air Brake retains any power of disposal, such as copying and transferring.

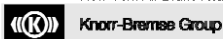



Maintenance Specification	
DB-10C	Doc.No.: NYR-481
	Revision: 02 9/18/17 - en

1.4 Referenced Documents

Table 1-1 Referenced Documents

Doc. ID	Doc. No	Issue (Index, ..)	Title
1	PC-790586		Parts Catalog, DB-10C
2	790586		Assembly Drawing, DB-10C
3	790586-SP		Serial Prefix Log

1.5 Danger, Warning, Caution, and Note (Notice) Messages

The symbols indicate that important personal safety information follows. Carefully read and understand each safety related text message and apply the message to the operation and maintenance of the system as defined in the safety alert message.

The following are definitions associated with the different safety alert message categories.

The words DANGER, WARNING, and CAUTION are used to identify levels of hazard seriousness for the safety of the personnel and the equipment.

The word DANGER is used to signify an immediate hazard and is used throughout this manual in the following manner:

	<p>DANGER</p> <p>INDICATES AN IMMINENTLY HAZARDOUS SITUATION, WHICH IF NOT AVOIDED, WILL RESULT IN DEATH OR SERIOUS INJURY. THIS WORD IS TO BE LIMITED TO THE MOST EXTREME SITUATIONS.</p>
--	---

The word WARNING is used to signify hazards or unsafe practices and is used throughout this manual in the following manner:

	<p>WARNING</p> <p>FAILURE TO COMPLY WITH THESE INSTRUCTIONS MAY LEAD TO IRREVERSIBLE PHYSICAL INJURIES WHICH MAY HAVE FATAL CONSEQUENCES.</p>
--	--

Copyright 2017© New York Air Brake. All rights reserved, including industrial property rights applications. New York Air Brake retains any power of disposal, such as copying and transferring.



Maintenance Specification
DB-10C Doc.-No.: NYR-481
Revision: 02 9/18/17 - en

The word CAUTION just like the word WARNING is used to signify hazards or unsafe practice in addition to equipment damage and is used throughout this manual in the following manner:

	CAUTION FAILURE TO COMPLY WITH THESE INSTRUCTIONS MAY LEAD TO PERSONAL INJURIES AND/OR TO DAMAGE TO THE UNIT OR THE ENVIRONMENT.
--	--

The NOTE (NOTICE) messages are used throughout this manual in the following manner:

	NOTE Notes do not contain any messages relevant to safety. Notes contain useful hints and additional information used to highlight suggestions which will result in enhanced installation, reliability, or operation.
--	--

Safety messages/notes have a specific structure which is explained here for DANGER (This also applies to WARNINGS and CAUTIONS):

	DANGER SOURCE OF THE DANGER CONSEQUENCES OF THE DANGER REMEDIAL MEASURES
--	---

Notes do not contain any messages relevant to safety and are included only for the sake of completeness.

	NOTE Notes contain useful hints and additional information about the unit.
--	--



Maintenance Specification

DB-10C	Doc.-No.: NYR-481
	Revision: 02 9/18/17 - en

2 PRODUCT IDENTIFICATION

2.1 Serial Prefix Identification

The DB-10C service portion has a nameplate that contains a serial number made up of Alpha and Numeric characters.

- The prefix characters of the serial number are an alpha/numeric combination located before the numeric characters. They identify the original manufacture revision level (example: first revision level starts with "A0", second revision level is "B0", etc.).
- The numeric characters identify the valve production number (this number runs consecutively starting with 00001).
- The suffix characters (if present), are an alpha/numeric combination and are located after the numeric characters. They identify the revision level of modifications, performed after original manufacture (example: B0-00789-F0). This suffix is added by the facility that performs the modifications.

Copyright 2017© New York Air Brake. All rights reserved, including industrial property rights applications.
New York Air Brake retains any power of disposal, such as copying and transferring.



Knorr-Bremse Group

Page 10 / 73



Maintenance Specification

DB-10C Doc.-No.: NYR-481
 Revision: 02 9/18/17 - en

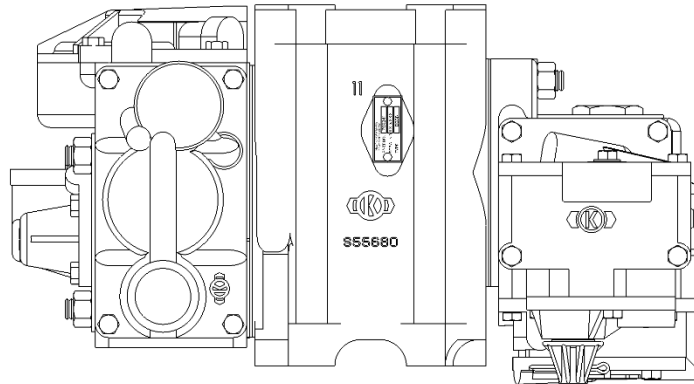

DB20
Emergency Portion

DB30
Pipe Bracket

DB-10C
Service Portion

Front View

776105ASSY1A

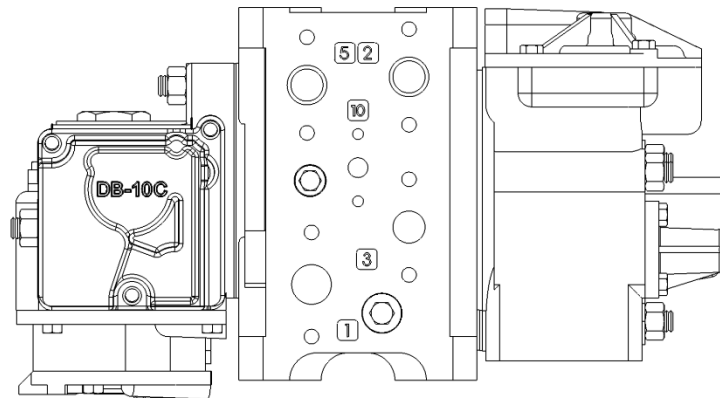

DB-10C
Service Portion

DB30
Pipe Bracket

DB20
Emergency Portion

Rear View

791188ASSY2A

Figure 2-1 DB-60 Control Valve Operating Portions and Double-Sided Pipe Bracket

Copyright 2017© New York Air Brake. All rights reserved, including industrial property rights applications.
 New York Air Brake retains any power of disposal, such as copying and transferring.





Maintenance Specification
 DB-10C Doc.No.: NYR-481
 Revision: 02 9/18/17 - en

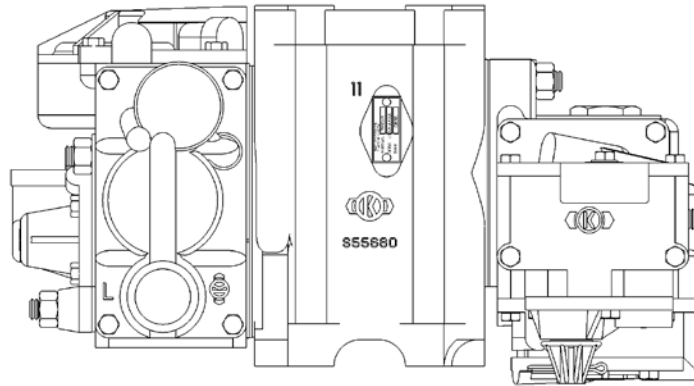

DB20L
Emergency Portion

DB30L
Pipe Bracket

DB-10C
Service Portion

Front View

776106ASSY1A

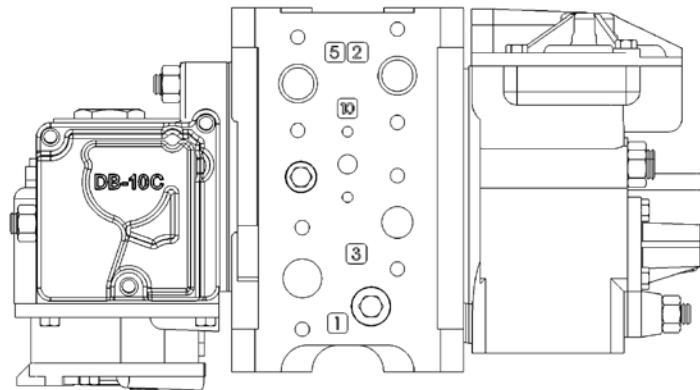

DB-10C
Service Portion

DB30L
Pipe Bracket

DB20L
Emergency Portion

Rear View

791169ASSY2A

Figure 2-2 DB-60L Control Valve Operating Portions and Double-Sided Pipe Bracket

Copyright 2017© New York Air Brake. All rights reserved, including industrial property rights applications.
 New York Air Brake retains any power of disposal, such as copying and transferring.



Knorr-Bremse Group



Maintenance Specification

DB-10C Doc.-No.: NYR-481
 Revision: 02 9/18/17 - en

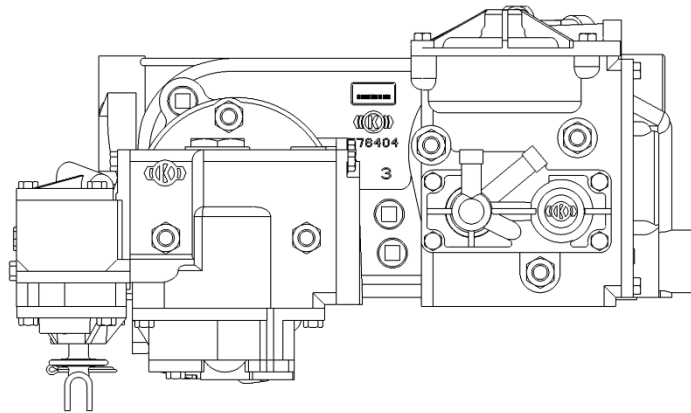

DB-10C
 Service Portion

DB30S
 Single Sided
 Pipe Bracket

DB20
 Emergency Portion

Front View

773616ASSY1A

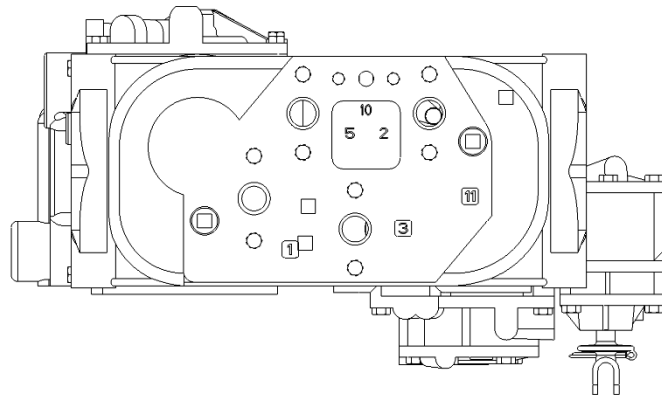

DB20
 Emergency Portion

DB30S
 Single Sided
 Pipe Bracket

DB-10C
 Service Portion

Rear View

773616ASSY2A

Figure 2-3 DB-60 Control Valve Operating Portions and Single-Sided Pipe Bracket

Copyright 2017© New York Air Brake. All rights reserved, including industrial property rights applications.
 New York Air Brake retains any power of disposal, such as copying and transferring.

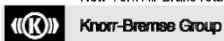



Maintenance Specification

DB-10C	Doc.-No.: NYR-481
	Revision: 02 9/18/17 - en

2.2 Product Structure

The DB-10C Service Portion consists of the DB10A Release Valve and the DB10B Service Valve Portion (Fig. 6-2). The DB10B Service Valve Portion consists of the Housing Assembly, DB10B Filler Piece Assembly, and Side Cover Assembly with their interior parts.

The DB-10C Service Portion is a component of the DB-60 II Control Valve, along with the DB20 and DB30 Portions (Figures 2-1, 2-2 and 2-3).

Copyright 2017© New York Air Brake. All rights reserved, including industrial property rights applications.
New York Air Brake retains any power of disposal, such as copying and transferring.



Knorr-Bremse Group

Page 14 / 73



Maintenance Specification

DB-10C Doc.No.: NYR-481
Revision: 02 9/18/17 - en

3 SAFETY AWARENESS

3.1 General Safety Awareness

1. Observe all rules and regulations where the equipment is being used. Whenever there is a conflict between the instructions in this manual and the instructions of the user, the rules and regulations of the user will govern.
2. De-pressurize air system before loosening connections or components. Before removing any component from its mountings, the train must be safely parked. To prevent personal injury, all main reservoir, brake supply reservoir, and brake cylinder air pressure on the affected vehicle must be vented.
3. "Bottled" up air under pressure (even though air supply is cut off) may cause gaskets and/or particles of dirt to become airborne and sound levels to increase when any component part is removed from the equipment arrangement. Personal eye and ear protection must be worn and care taken to avoid possible injury when performing any work on these component parts.
4. The use of an air jet, which must be less than 30 PSI, to blow parts clean or to blow them dry after being cleaned with a solvent will cause particles of dirt and/or droplets of the cleaning solvent to be airborne. These particles and droplets may cause skin and /or eye irritation. Personal eye protection must be worn to protect the eyes from possible injury. When using an air jet, do not direct it toward another person.
5. If degreasing fluids are used for cleaning purposes, the current local safety regulations plus the safety precautionary statements of the manufacturer of the cleaning agent must be adhered to. Otherwise, physical harm could result from the inhalation of toxic fumes. Make sure the area is well ventilated when working with materials that produce harmful fumes.
6. Personal eye protection must be worn when doing any work to protect eyes from possible injury.
7. Where fasteners removed from the equipment are not satisfactory for reuse, care must be taken to select replacements that match the originals. Mismatched or incorrect fasteners can result in equipment damage or malfunction, or possible personal injury.
8. To ensure the correct functioning of each component, use only the manufacturers genuine spare parts as replacements.
9. Follow all DANGERS, WARNINGS, CAUTIONS, and NOTES found throughout this specification. If you must use a work procedure or tool which is not recommended, you must first satisfy yourself that neither your safety, nor your fellow workers safety, nor that of the equipment will be jeopardized by the method selected.
10. Any person performing maintenance and/or operational tasks with the brake system and system components is required to have the appropriate job skill level, as governed by the user.

Copyright 2017© New York Air Brake. All rights reserved, including industrial property rights applications.
New York Air Brake retains any power of disposal, such as copying and transferring.



Knorr-Bremse Group

Page 15 / 73



Maintenance Specification	
DB-10C	Doc.No.: NYR-481
	Revision: 02 9/18/17 - en

4 TOOLS REQUIRED

Overhaul of the DB-10C will be accomplished in a more efficient and safe manner through the use of the following standard and special tools.

4.1 Standard Tools

1. Box end wrenches or square drive socket wrenches for hex cap screws with wrench openings of 9/16", 17/32", 3/4", 31/32", 1-5/8" and 1-13/16".
2. Allen wrenches with 3/16" and 15/64" width across flats.
3. A flat blade screwdriver for slotted head screws with screwdriver point dimensions of 3/64" x 11/32".
4. Offset snap ring pliers for internal retaining rings with 70°, 1/16" tip.
5. Offset pointed tweezers (7°) with overall length of approximately 5".
6. A pin punch with 0.1" diameter maximum pin dimension.
7. A metal marking scriber with a straight and a hooked end.

4.2 Special Tools

- A flat blade screwdriver for slotted head screws with a modified screwdriver point.
- Use a standard flat blade screwdriver with screwdriver point dimensions of 3/64" x 11/32" and reduce the width of the blade from 11/32" to 10/32" maximum by grinding.

The following special tools are required. Drawings are shown in Section 11.

Quick Service Valve Removal Tool.....	Fig. 11-5.....	P/N 772615
Quick Service Inlet Valve Positioning Tool	Fig. 11-6.....	P/N 772616
Special Hand Drive Pin	Fig. 11-7.....	P/N 772617
Retaining Clamp.....	Fig. 11-8.....	P/N 772618
Guide Pin (3 required).....	Fig. 11-9	P/N 772620
Bushing Extractor.....	Fig. 11-10.....	P/N 772624
Retaining Ring Positioning Tool	Fig. 11-11.....	P/N 772625
K-Ring Positioning Tool.....	Fig. 11-12.....	P/N 772626
Thin Wall Type Mandrel	Fig. 11-13.....	P/N 772628
12mm Bore Gage.....	Fig. 11-14.....	P/N 790505
17mm Bore Gage.....	Fig. 11-15.....	P/N 790506
Spacer Ring Assembly Tool.....	Fig. 11-16.....	P/N 773069

❖ Special tools may be either fabricated by the user or purchased through the OEM.

Copyright 2017© New York Air Brake. All rights reserved, including industrial property rights applications.
 New York Air Brake retains any power of disposal, such as copying and transferring.

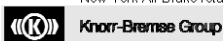



Maintenance Specification

DB-10C	Doc.-No.: NYR-481
	Revision: 02 9/18/17 - en

5 ADHESIVES, LUBRICANTS, SEALANTS, AND SOLVENTS

The following lubricants and sealants / liquid fastening aids are used when assembling the DB-10C Service Portion. Adhesives and solvents are not identified within this document.

5.1 Lubricants

- Dow Corning 55 Silicone Grease

5.2 Sealants

- Alodine (brush-on)
- Black Oxide Primer

Copyright 2017© New York Air Brake. All rights reserved, including industrial property rights applications.
New York Air Brake retains any power of disposal, such as copying and transferring.



Knorr-Bremse Group

Page 17 / 73



Maintenance Specification	
DB-10C	Doc.-No.: NYR-481
	Revision: 02 9/18/17 - en

6 DISASSEMBLY

6.1 Cleaning

1. All maintenance work starts with the initial external cleaning of the control valve portion with the shipping covers still in place (Refer to Fig. 10-2).

	WARNING
	DANGER OF PERSONAL INJURY EXISTS. WHEN USING SOLVENTS, BE SURE TO: <ul style="list-style-type: none">• WEAR EYE, SKIN, AND RESPIRATORY PROTECTION.• WORK IN A WELL VENTILATED AREA.• AVOID REPEATED OR PROLONGED CONTACT.• KEEP SOLVENT CONTAINER CLOSED.• KEEP SOLVENT AWAY FROM SPARKS, FLAMES, AND HEAT.
	FAILURE TO OBSERVE THESE SAFETY PRECAUTIONS CAN LEAD TO INJURY OR INTOXICATION.

	WARNING
	DANGER OF PERSONAL INJURY EXISTS. WHEN USING COMPRESSED AIR, BE SURE TO: <ul style="list-style-type: none">• WEAR EYE PROTECTION.• DO NOT EXCEED 30 PSI.

	CAUTION
	VALVE BODIES SHOULD NOT BE SUBMERGED IN A SOLUTION.

2. Once the valve body has been cleaned by an approved method, the shipping covers can be removed and disassembly may begin.
3. The DB-10C Service Portion must be completely disassembled and all parts inspected, cleaned and lubricated at a suitable bench in a clean, well-lighted location in an A.A.R. approved air brake shop.

Copyright 2017© New York Air Brake. All rights reserved, including industrial property rights applications.
New York Air Brake retains any power of disposal, such as copying and transferring.



Maintenance Specification	
DB-10C	Doc.No.: NYR-481
	Revision: 02 9/18/17 - en

6.2 General Requirements

1. Use the tools specified in Section 4.0.
2. It is recommended that suitable devices be made to hold the valve bodies in place during the disassembly/assembly process. In addition, it would be helpful if the valve body could be rotated horizontally by 360 degrees on this device with locking features every 90 degrees.
3. Remove and install KNORR K-Rings only in accordance with the instructions given in Fig. 6-1.
4. If necessary, use the K-Ring Positioning Tool (Figure 11-15) and / or tweezers only, to remove and install springs, valve plates, K-Rings or O-Rings.
5. Prevent damage or abrasion to all parts of the valve, particularly machined surfaces during disassembly, cleaning and assembly.
6. The covers are used not only as sealing surfaces, but also to support various component parts. When removing/attaching covers and/or sub-components, exercise care to prevent the loss of springs, chokes, valve seats or rubber parts.
7. Some covers are recessed at the flange face. These covers cannot be knocked off laterally. If they do not loosen automatically after cap screw removal, they can be pried out by inserting a suitable flat blade screwdriver in the opposing, built-in recess.
8. The non-recessed covers should come off automatically by spring force once the cap screws have been removed. If not, they can be tapped off laterally using a soft-faced mallet.

NOTICE

NOTE

For proper location of main piston system, valves, and chokes, refer to Figures 6-2, 6-3, and 6-4.

For proper location of all parts identified by reference number, refer to Section 11.



Maintenance Specification	
DB-10C	Doc.-No.: NYR-481
	Revision: 02 9/18/17 - en

6.3 Disassembly of DB-10C Service Portion

 WARNING	WARNING COMPRESSED FORCES MAY INADVERTENTLY EXPEL PARTS. WEAR EYE PROTECTION AND EXERCISE CARE DURING DISASSEMBLY. FAILURE TO OBSERVE THESE SAFETY PRECAUTIONS CAN LEAD TO INJURY.
--	--

NOTICE	NOTE These instructions are to be performed after the DB-10C Service Portion is removed from the DB-30 Pipe Bracket and applies to DB-10C Service Portions that are at any configuration level. Distortion of bolts, nuts, etc. must be avoided by using tools especially adapted for this work (Refer to Section 4). Care must be taken to ensure that pistons, springs, chokes, rubber parts, etc. are protected from damage.
---------------	---

6.3.1 DISASSEMBLY OF DB-10C SERVICE PORTION

(Refer to Figure 11-1)

NOTICE	NOTE To hold the valve from moving during disassembly, it may be beneficial to attach the valve to a suitable holding fixture.
---------------	--

1. Remove cap screws (2 and 3) which secure the release valve housing (1) to the basic valve housing (6).

NOTICE	NOTE Separate release valve housing (1) carefully to prevent the loss of valve parts.
---------------	---

2. Remove seven O-Rings (5) with K-Ring Positioning Tool (Fig. 11-12) before removing choke (4) (C 6.1) from release valve housing (1) flange face. Discard O-Rings (5).
3. Rotate the valve housing (6) so side cover (28) is face up.

Copyright 2017© New York Air Brake. All rights reserved, including industrial property rights applications.
New York Air Brake retains any power of disposal, such as copying and transferring.

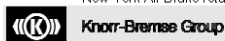



Maintenance Specification

DB-10C Doc.No.: NYR-481
Revision: 02 9/18/17 - en

CAUTION EXERCISE CARE TO PREVENT DAMAGE TO THE MACHINED SEALING SURFACE ON THE OPPOSITE SIDE OF THE HOUSING WHEN ROTATING THE VALVE HOUSING.

CAUTION REMOVE COVER (28) CAREFULLY TO PREVENT DAMAGE TO THE SEALING SURFACES.

CAUTION EXERCISE CARE TO PREVENT THE LOSS OF VALVE PARTS WHEN REMOVING COVER.

4. Remove cap screws (2) and lift off cover (28) carefully.
5. Use K-Ring Positioning Tool (Fig. 11-15) to extract O-Rings (5, 29, 35 and 37). Discard O-Rings (5, 29, 35 and 37). [Also – O-Ring (66) with Cast Iron side cover (28)]
6. Remove spring (33), spring guide (20), diaphragm (21), spring guide (10 or 11), spring (34) and check valve (12). Discard check valve (12) and diaphragm (21).
7. Remove spring (30), check valve (31), retaining ring (31A) if present, and filter (32). Discard check valve (31), retaining ring (31A) if present, and filter (32).
8. Remove exhaust bushing (65).
9. Remove spring (19), spring guide (20) and diaphragm (21). Unscrew threaded bushing (22) with a 3/4" socket wrench then remove check valves (23), spring (25), O-Ring (24), spring (27) and bushing (26). Discard two check valves (23), O-Ring (24), spring (19) and diaphragm (21).

NOTE If ring (9) is present and made of steel, protect the radius of threaded bushing (13) by using protection ring (Fig. 11-12) before removing steel ring (9) with a suitable screwdriver.

10. Remove spring (7), diaphragm (8), spacer ring (9) if present, spring guide (10) and check valve (12). Unscrew threaded bushing (13 or 14) with a 1-5/8" socket wrench. Remove spring guide (16), spring (17) and check valve (18) with tweezers. Discard check valves (12 & 18), spring (7) and diaphragm (8).

Copyright 2017© New York Air Brake. All rights reserved, including industrial property rights applications.
New York Air Brake retains any power of disposal, such as copying and transferring.

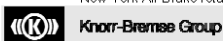



Maintenance Specification	
DB-10C	Doc.-No.: NYR-481
	Revision: 02 9/18/17 - en

11. Remove and discard O-Ring (15) from threaded bushing (13 or 14).
12. Remove O-Ring (35) and choke (36) from housing (6). Discard O-Ring (35).

NOTICE

NOTE

If the valve is attached to a holding fixture, remove basic valve housing (6) for further disassembly.

6.3.2 DISASSEMBLY OF DB-10C HOUSING ASSEMBLY

(Refer to Figure 11-2)

NOTICE

NOTE

Remove filler piece assembly (58) slowly to prevent springs and spring-loaded parts from becoming airborne.

- 6.3.2.1. With filler piece assembly (58) facing up, remove cap screws (2). Lift off filler piece assembly (58). Remove and discard O-Ring (57) and then set filler piece assembly (58) to one side.
- 6.3.2.2 Remove piston subassembly (47-56) from housing (6).

WARNING

WARNING

PARTS MAY BE INADVERTENTLY EXPELLED BY FORCE OF SPRING. WEAR EYE PROTECTION AND EXERCISE CARE DURING DISASSEMBLY. FAILURE TO OBSERVE THESE SAFETY PRECAUTIONS CAN LEAD TO INJURY.

6.3.2.3 DISASSEMBLY OF PISTON SUBASSEMBLY (47-56)

(Refer to Figure 11-2)

- a. Install piston subassembly (47-56) into clamping fixture with spring guide (54) facing up.
- b. To relieve spring (53) force acting on retaining ring (56), push down on spring guide (54) with the aid of Retaining Clamp (Fig. 11-8) and a press. While holding the press, remove retaining ring (56) by pushing out with Retaining Ring Positioning Tool (Fig. 11-11). Discard retaining ring (56).

Copyright 2017© New York Air Brake. All rights reserved, including industrial property rights applications.
New York Air Brake retains any power of disposal, such as copying and transferring.



Knorr-Bremse Group

Page 22 / 73



Maintenance Specification

DB-10C Doc.No.: NYR-481
Revision: 02 9/18/17 - en

NOTICE

NOTE

Retaining ring (56) must be completely removed from its groove before the press is slowly moved to its neutral position to ensure that the force of spring (53) will be fully relieved.

- c. Remove guide ring (55), spring guide (54) and spring (53). Discard spring (53).
- d. Remove nut (51) and key (52) from piston plate (50).
- e. Remove piston plate (50), stem (47) and diaphragm (49) from piston assembly (48). Discard diaphragm (49).

6.3.2.4 Remove and discard one O-Ring (61) and four O-Rings (34) from housing (6).



WARNING

PARTS MAY BE INADVERTENTLY EXPELLED BY FORCE OF SPRING. WEAR EYE PROTECTION AND EXERCISE CARE DURING DISASSEMBLY. FAILURE TO OBSERVE THESE SAFETY PRECAUTIONS CAN LEAD TO INJURY.

- 4. Loosen threaded bushing (46) by using a 1-13/16" socket wrench.
- 5. Unscrew threaded bushing (46) carefully by hand, so the force of spring (43) is fully relieved before all parts of the main piston system are removed.

NOTICE

NOTE

If spring guide (44) is still in its locked position and spring (43) and piston stem (45) remain in housing (6), use Quick Service Inlet Valve Positioning Tool (Fig. 11-6) to release this locked position by pressing and carefully rotating spring guide (44) 90° counter-clockwise.

- 6. Remove check valve (10), stem (45), spring guide (44), and spring (43) from housing (6). Discard check valve (10).
- 7. Remove O-ring (38) from threaded bushing (46) and O-ring (35) from stem (45). Discard O-rings (38 and 35). Refer to Section 7.2 for gauging and inspection guidelines for threaded bushing (46).

Copyright 2017© New York Air Brake. All rights reserved, including industrial property rights applications.
New York Air Brake retains any power of disposal, such as copying and transferring.



Knorr-Bremse Group

Page 23 / 73



Maintenance Specification

DB-10C Doc.No.: NYR-481
Revision: 02 9/18/17 - en



CAUTION

EXERCISE CARE TO PREVENT DAMAGE TO THE VALVE SEAT RADIUS OF STEM (45).

8. Visually inspect stem (45) per guidelines in Section 7.2. Unscrew and discard choke assembly (59) with a suitable Allen wrench or screwdriver.
9. Unscrew choke (60) with a suitable Allen wrench or screwdriver. Inspect choke (60) per guidelines in Section 7.3.
10. Rotate basic valve housing (6) so that threaded bushing (37) is face up.
11. Loosen threaded bushing (37) by using a 1-13/16" socket wrench.



WARNING

PARTS MAY BE INADVERTENTLY EXPELLED BY FORCE OF SPRING. WEAR EYE PROTECTION AND EXERCISE CARE DURING DISASSEMBLY. FAILURE TO OBSERVE THESE SAFETY PRECAUTIONS CAN LEAD TO INJURY.

12. Unscrew bushing (37) carefully by hand, so the force of spring (39) is fully relieved before spring (39) and bushing (41) are removed.
13. Remove spring (39) and check valve (10) from housing (6). Discard check valve (10).
14. Remove and discard O-Ring (38) from threaded bushing (37). Inspect threaded bushing (37) per general guidelines in Section 7.2.
15. Use K-Ring Positioning Tool (Fig. 11-12) to remove O-Ring (40) before removing valve seat bushing (41) with Bushing Extractor (Fig. 11-10). Discard O-Ring (40).



CAUTION

EXERCISE CARE TO PREVENT DAMAGE TO THE VALVE SEAT RADIUS OF VALVE SEAT BUSHING (41).

16. Remove and discard K-Ring (42) from bushing (41).
17. Use a suitable Allen wrench or screwdriver to unscrew choke (62) from the pipe bracket flange face of the basic valve housing (6). Visually inspect any straight-through bushing bores in housing (6) per guidelines in Section 7.2. Inspect choke (62) per guidelines in Section 7.3.

Copyright 2017© New York Air Brake. All rights reserved, including industrial property rights applications.
New York Air Brake retains any power of disposal, such as copying and transferring.



Knorr-Bremse Group

Page 24 / 73



Maintenance Specification	
DB-10C	Doc.No.: NYR-481
	Revision: 02 9/18/17 - en

6.3.3 DISASSEMBLY OF DB-10C FILLER PIECE ASSEMBLY

(Refer to Figure 11-3)

For Cast Iron Service Portions P/N I85200/001D with S/N A0-XXXXX thru S/N D0-XXXXX:

1. With cover (43) facing down, remove retaining ring (20) with suitable pliers. Remove stem (17). Discard retaining ring (20).
2. Remove retaining ring (20) and stem (18) from cover (1). Use K-ring Positioning Tool (Fig. 11-15) to remove sealing ring (19) from the AR-charging valve chamber in housing (1).
3. Discard sealing ring (19), retaining ring (20) and stem (18).
4. Remove retaining ring (20) and balancing valve stem (13). Discard retaining ring (20).

 CAUTION	CAUTION EXERCISE CARE TO PREVENT DAMAGE TO THE VALVE SEAT RADIUS OF STEM (13).
--	--

5. Use K-Ring Positioning Tool (Fig. 11-15) to remove K-Ring (16), washer (15) and spring (14) from the balancing valve stem (13). Discard K-Ring (16). Visually inspect seat of stem (13) per general guidelines in Section 7.2. Refer to gauging guidelines in Section 7.2 for gauging length of stem (13).
6. Proceed to the next step for the remainder of disassembly.

For Cast Iron Service Portions P/N I85200/001D starting with S/N E0-XXXXX and Aluminum Service Portions P/N 775868 starting with A0-XXXXX:

1. With cover (43) facing up, remove cap screws (44), with a 9/16" wrench. Lift off cover (43).

 NOTICE	NOTE Remove cover (43) slowly to prevent springs and spring loaded parts from becoming airborne.
---	--

2. Remove pop rivet (47), by drilling the head of the rivet with a 3/16" drill (Ø 5 mm max.). Remove and discard pop rivet (47), spacer ring (46) and vent flap (45) from cover (41).

Copyright 2017© New York Air Brake. All rights reserved, including industrial property rights applications.
New York Air Brake retains any power of disposal, such as copying and transferring.

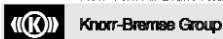



Maintenance Specification

DB-10C Doc.No.: NYR-481
Revision: 02 9/18/17 - en



CAUTION

EXERCISE CARE TO PREVENT CHIPS FROM REMAINING IN COVER (43).



NOTE

Use K-Ring Positioning Tool (Fig. 11-12) and/or tweezers whenever necessary.

3. Remove O-ring (2), spring (29), spring seat (24) if present, check valve (23), bushing (27) with attached O-rings (22), [sealing ring (19), and stem (18) starting at S/N E0-XXXXX for P/N I85200/001D and starting at S/N A0-XXXXX for P/N 775868] from cover (1). Discard check valve (23), O-rings (2 & 22) and sealing ring (19).
4. Remove O-ring (33), bushing (32), check valve (31), and spring (30) from cover (1). Discard O-ring (33) and check valve (31).
5. Remove O-ring (2), spring (28), check valve (23), bushing (27) with O-rings (22), [and stem (17) starting at S/N E0-XXXXX for P/N I85200/001D and starting at S/N A0-XXXXX for P/N 775868], from cover (1). Discard check valve (23) and O-Rings (2 & 22).



NOTE

Use Quick Service Valve Removal Tool (Fig. 11-5) to push out piston (5) and bushings (3 & 9).

6. Remove O-Ring (10), spring (12), check valve (11), bushing (9) with O-Rings (8), piston (5) with K-Rings (4 & 6) and O-Ring (7), and bushing (3) with O-Ring (2) from cover (1). Discard O-Rings (2, 7, 8 & 10), K-Rings (4 & 6) and check valve (11).



NOTE

For P/N I85200/001D, on units prior to S/N D0-XXXXX, remove O-Ring (2A) and discard. Do not replace.

7. Remove O-Ring (2), filter (26), spring (25), spring seat (24), check valve (23), bushing (21) with two attached O-Rings (22), [stem (13) with attached spring (14), washer (15), and K-Ring (16) starting at S/N E0-XXXXX for P/N I85200/001D and starting at S/N A0-XXXXX for P/N 775868] from cover (1). Discard O-Rings (2 & 22), K-Ring (16), spring seat (24), check valve (23), spring (25) and filter (26). Inspect bushing (21) per general guidelines in Section 7.2.

Copyright 2017© New York Air Brake. All rights reserved, including industrial property rights applications.
New York Air Brake retains any power of disposal, such as copying and transferring.



Knorr-Bremse Group

Page 26 / 73



Maintenance Specification	
DB-10C	Doc.-No.: NYR-481
	Revision: 02 9/18/17 - en

NOTICE NOTE
Use Quick Service Valve Removal Tool (Fig. 11-5) to push out piston (41).

8. Remove O-ring (39), piston (41) with K-Rings (40 & 42), and bushing (38) with O-Rings (36 & 37) from cover (1). Discard O-Rings (36, 37 and 39) and K-Rings (40 & 42). Inspect bore of piston (41) per gauging guidelines in Section 7.2.
9. Remove and discard O-Rings (34 & 35) from cover (1).

6.4 Disassembly of DB-10C Release Valve

(Refer to Figure 11-4)

1. Rotate release valve portion so the release valve lower cover (30) is face up. Remove cap screws (1). Lift off cover (30).
2. Remove sleeve (29), release valve handle (28), lifter (27), spring (26), stem (25), spring guide (23) and spring (22) from release valve housing assembly (7).
3. Remove and discard O-Ring (24) from stem (25). Inspect stem (25) per general guidelines in Section 7.2.
4. Remove and discard pop rivet (33) by drilling the head of the rivet with 3/16" drill (Ø 5 mm max.).
5. Remove and discard spacer ring (32) and vent flap (31) from cover (30).

CAUTION CAUTION
EXERCISE CARE TO PREVENT CHIPS FROM REMAINING IN COVER (30).

6. Remove and discard O-Ring (3) from housing (7) (use K-Ring Positioning Tool (Fig. 11-12) and / or tweezers).
7. Rotate service portion so the release valve upper cover (2) is face up. Remove cap screws (1), and also flat washer (36) and CID tag (37) if they are present. Lift off cover (2).

CAUTION CAUTION
EXERCISE CARE TO PREVENT DAMAGE TO THE VALVE SEAT RADIUS OF BUSHING (19).

Copyright 2017© New York Air Brake. All rights reserved, including industrial property rights applications.
New York Air Brake retains any power of disposal, such as copying and transferring.

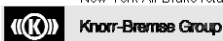



Maintenance Specification

DB-10C Doc.No.: NYR-481
Revision: 02 9/18/17 - en

NOTICE

NOTE

Use K-Ring Positioning Tool (Fig. 11-12) and/or tweezers whenever necessary.

8. Remove bushing (19), spring (20) and check valve (21) from housing assembly (7). Discard check valve (21) and spring (20). Visually inspect seat and choke in bushing (19) per general guidelines in Section 7.2.
9. Remove and discard three O-Rings (3), O-Ring (8) and two O-Rings (18) from housing (7).
10. Remove two springs (4), two check valves (5) and two stems (6) from housing (7). Discard check valves (5).

CAUTION

CAUTION

EXERCISE CARE TO PREVENT DAMAGE TO SEALING SURFACES.

11. Rotate release valve portion so the release valve lower cover (30) mounting surface is face up.
12. Unscrew hex locknut (17) while holding piston (9) in place with a properly fitted screwdriver. Discard hex locknut (17).
13. Remove bushing (16), check valve (14) and spring (13) from end of piston (9). Discard check valve (14).
14. Remove and discard O-ring (15) from bushing (16).
15. Remove piston (9) from housing (7). Visually inspect both piston (9) and release valve bore and internal choke in housing (7) per general guidelines in Section 7.2.
16. Remove and discard two O-Rings (11 & 12) and K-Ring (10) from piston (9).

Copyright 2017© New York Air Brake. All rights reserved, including industrial property rights applications.
New York Air Brake retains any power of disposal, such as copying and transferring.



Knorr-Bremse Group

Page 28 / 73



Maintenance Specification	
DB-10C	Doc.-No.: NYR-481
	Revision: 02 9/18/17 - en

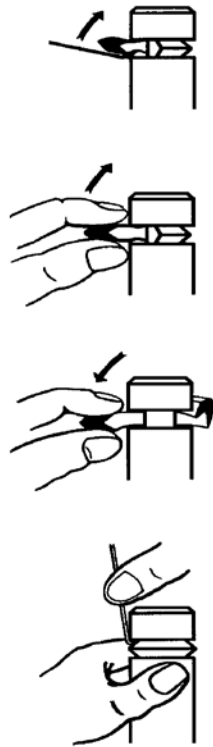

REMOVAL

Remove K-ring from groove with K-ring positioning tool and pull out completely by hand.

or:

Stretch K-ring by squeezing and pushing toward one side using the thumb and forefinger. It will come out of the groove on the opposite side. Remove by hand.

INSTALLATION

Pull slightly greased K-ring over shaft.

Expand K-ring to one side. Then manually slide it with the sealing lips ahead into the groove.

Repeat procedure until K-ring is completely inserted into the groove.

As a safety measure, move K-ring positioning tool all around between K-ring and groove wall.

CAUTION

Do not use pointed tools.
Do not damage the groove flanks.

KRINGINST1

Figure 6-1 Removal and Installation Instructions for KNORR K-Rings (outer lip seal)

Copyright 2017© New York Air Brake. All rights reserved, including industrial property rights applications.
New York Air Brake retains any power of disposal, such as copying and transferring.

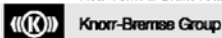



Maintenance Specification
 DB-10C Doc.-No.: NYR-481
 Revision: 02 9/18/17 - en

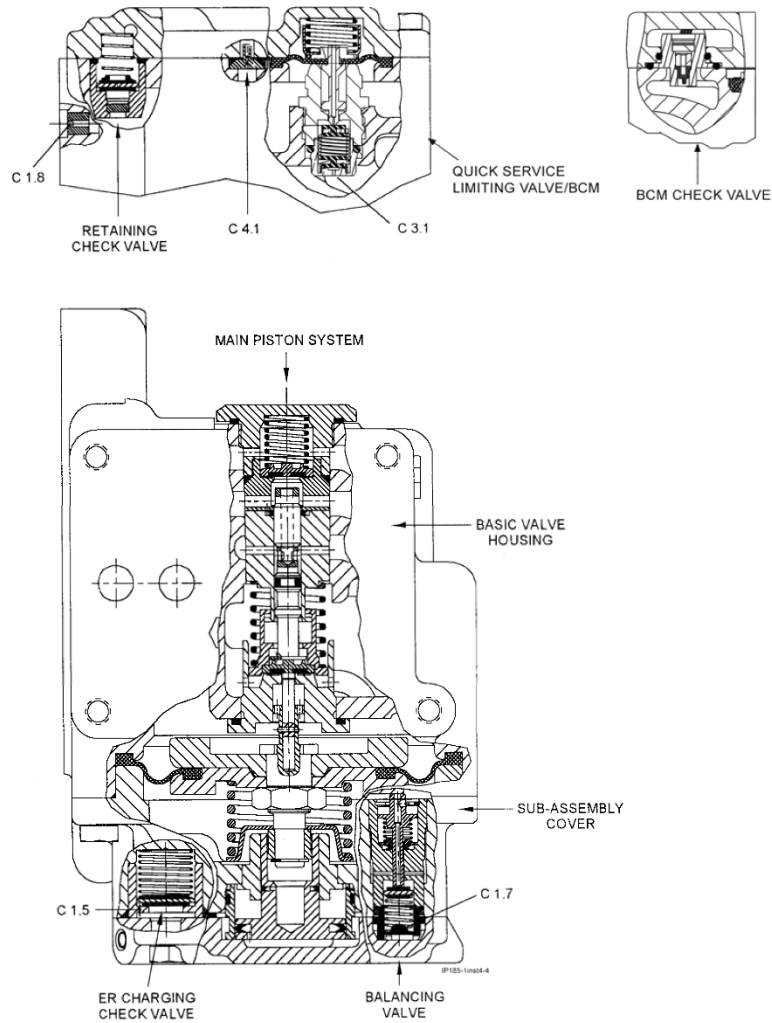
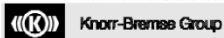

Figure 6-2 DB-10C Service Portion Basic Valve (Assembly View)

Copyright 2017© New York Air Brake. All rights reserved, including industrial property rights applications.
 New York Air Brake retains any power of disposal, such as copying and transferring.





Maintenance Specification

DB-10C	Doc. No.: NYR-481
	Revision: 02 9/18/17 - en

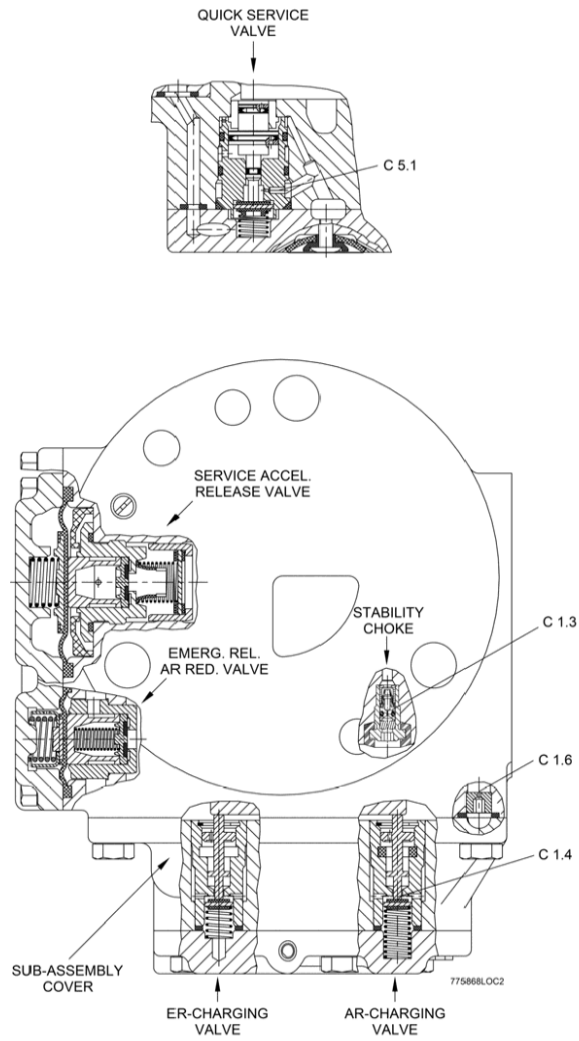

Figure 6-3 DB-10C Service Portion Basic Valve (Assembly View)

Copyright 2017© New York Air Brake. All rights reserved, including industrial property rights applications.
 New York Air Brake retains any power of disposal, such as copying and transferring.



Knorr-Bremse Group



Maintenance Specification

DB-10C	Doc. No.: NYR-481
	Revision: 02 9/18/17 - en

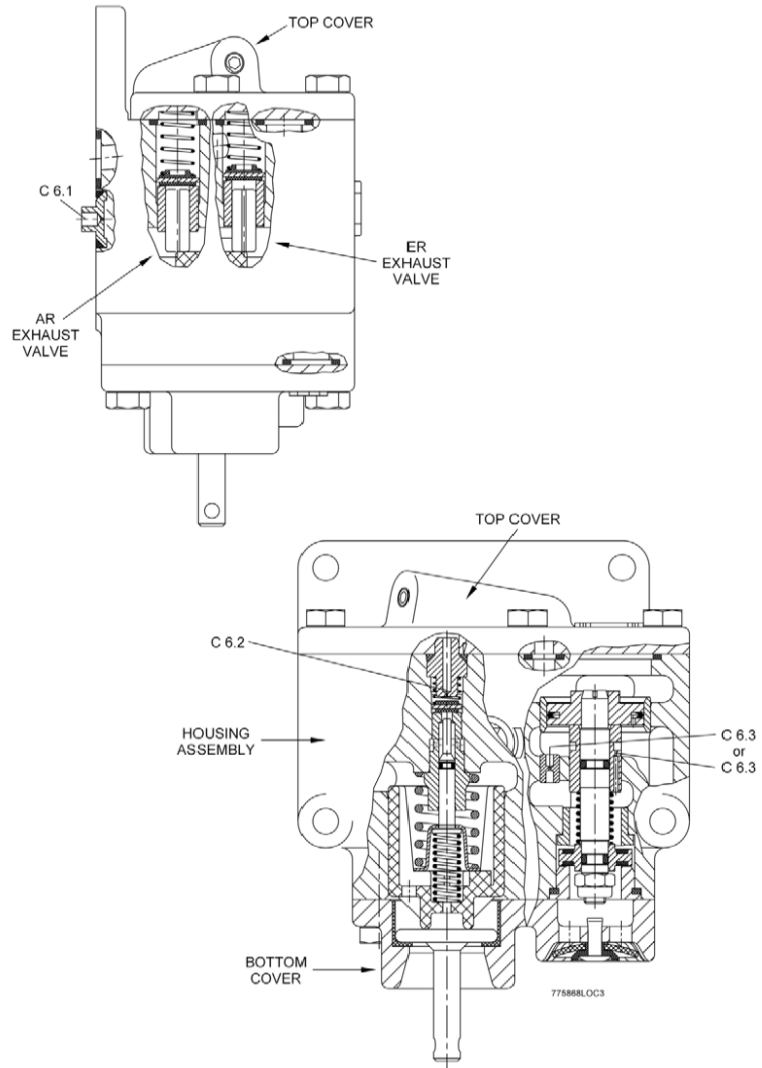
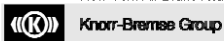

Figure 6-4 Release Valve (Assembly View)

Copyright 2017© New York Air Brake. All rights reserved, including industrial property rights applications.
 New York Air Brake retains any power of disposal, such as copying and transferring.





Maintenance Specification
DB-10C Doc.No.: NYR-481
Revision: 02 9/18/17 - en

7 CLEANING, INSPECTING AND REPAIRING

7.1 Cleaning

	WARNING
	DANGER OF PERSONAL INJURY EXISTS. WHEN USING SOLVENTS, BE SURE TO: <ul style="list-style-type: none">• WEAR EYE, SKIN, AND RESPIRATORY PROTECTION.• WORK IN A WELL VENTILATED AREA.• AVOID REPEATED OR PROLONGED CONTACT.• KEEP SOLVENT CONTAINER CLOSED.• KEEP SOLVENT AWAY FROM SPARKS, FLAMES, AND HEAT.
	FAILURE TO OBSERVE THESE SAFETY PRECAUTIONS CAN LEAD TO INJURY OR INTOXICATION.

	CAUTION
	VALVE BODIES SHOULD NOT BE SUBMERGED IN A SOLUTION.

1. After complete disassembly, all parts, including the interior of the body, must be thoroughly cleaned by an approved method that will dissolve oil and grease without damage or abrasion to the parts.

	WARNING
	DANGER OF PERSONAL INJURY EXISTS. WHEN USING COMPRESSED AIR, BE SURE TO: <ul style="list-style-type: none">• WEAR EYE PROTECTION.• DO NOT EXCEED 30 PSI.

2. All parts, including the body, must be blown dry after cleaning.
3. Light surface corrosion on cast iron or aluminum parts must be removed by carefully cleaning with crocus cloth or emery paper. Corrosion protection that was removed and exposes bare metal must be re-applied to the affected area. For aluminum parts, apply a brush-on Alodine solution. For cast iron parts, apply a black oxide primer. Applications must be applied according to the manufacturer's specifications listed on the container.

Copyright 2017© New York Air Brake. All rights reserved, including industrial property rights applications.
New York Air Brake retains any power of disposal, such as copying and transferring.

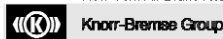



Maintenance Specification	
DB-10C	Doc. No.: NYR-481
	Revision: 02 9/18/17 - en

7.2 Inspecting

1. Carefully inspect cleaned parts. If damaged (cracked, deformed or signs of rust or thread damage), replace component.
2. Visually inspect sealing, sliding and guide surfaces for scoring, scratches and excessive wear. Also examine valve seats for scoring, scratches and indentations.
3. Replace parts if scoring or scratches deeper than 0.2 mm are detected on sealing, sliding or guide surfaces, or if smaller defects cannot be fully removed during reconditioning.
4. Replace all parts that are cracked, broken, worn, damaged, or in such a condition as would result in unsatisfactory operation.

5. GAUGING:

Threaded Bushing (Item 46) (Fig. 11-2) (page 60)

Maximum allowable diameter of large bore is 12.027 mm (see Figure 7-1). If greater than 12.027 mm, then the component must be replaced. Use 12mm Bore Gage (Figure 11-14) to measure diameter.

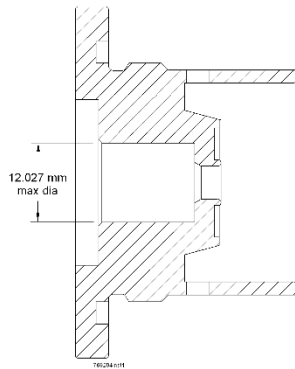

Figure 7-1 Threaded Bushing

Copyright 2017© New York Air Brake. All rights reserved, including industrial property rights applications.
New York Air Brake retains any power of disposal, such as copying and transferring.



Maintenance Specification

DB-10C	Doc.No: NYR-481
	Revision: 02 9/18/17 - en

Stem (Item 13) (Fig. 11-3) (page 62) – Visually inspect seat of stem per general guidelines in Section 7.2. Minimum allowable length of component is 34.350 mm. If less than 34.350 mm, then the component must be replaced.

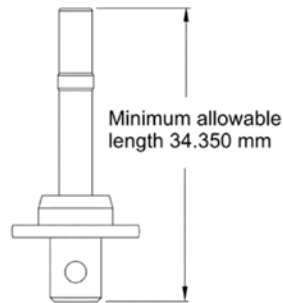

Figure 7-2 Stem

Balancing Piston (Item 41) (Fig. 11-3) (page 62) – maximum allowable inside entry diameter is 17.041 mm (see Figure 7-3). If greater than 17.041 mm, then the component must be replaced. Use 17mm Bore Gage (Figure 11-15) to measure diameter.

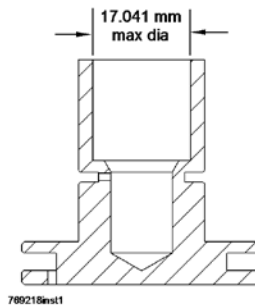

Figure 7-3 Balancing Piston

Copyright 2017© New York Air Brake. All rights reserved, including industrial property rights applications.
New York Air Brake retains any power of disposal, such as copying and transferring.



Maintenance Specification	
DB-10C	Doc.No.: NYR-481
	Revision: 02 9/18/17 - en

7.3 Springs

1. If not discarded and replaced, all springs must be inspected after cleaning.
2. Springs that show distortion, corrosive pitting, cracks, or have permanent set, must be rejected and replaced by springs known to be correct.
3. For proper spring identification, refer to Table 7-1.
4. There are 21 springs used throughout the service portion.
5. Spring (4), (Fig. 11-4) is required twice; all others once.
6. Table 7-1 is intended for identification only and should not be used for any other purpose. It does not represent specifications for these springs. Actual springs may vary due to small differences in dimensions.

Table 7-1 Spring Identification

Fig. No.	Ref. No.	Designation	Approx. Outside Dia. mm (inch)	Approx. Wire Dia. mm (inch)	Approx. Free Height mm (inch)	Approx. No. of Turns
11-1	7	Service Accelerated Release Valve Spring (Green)	19.3 (0.763)	1.5 (0.055)	26 (1.090)	5.5
11-1	17	Back Flow Check Valve Spring	16 (0.630)	0.8 (0.031)	22.1 (0.870)	10.5
11-1	19	QS Limiting Valve Spring (Red)	19.3 (0.760)	1.5 (0.059)	29.3 (1.153)	5.3
11-1	25	QS Limiting Check Valve Spring	10.3 (0.406)	0.8 (0.031)	14.6 (0.575)	8.5
11-1	30	Retaining Check Valve Spring	11.5 (0.453)	0.5 (0.020)	31.2 (1.228)	5.5
11-1	33	Emergency Release AR Reduction Valve Spring	17.8 (0.700)	1.8 (0.071)	28.3 (1.115)	5.0
11-1	34	Emergency Release AR Reduction Check Valve Spring	8.8 (0.347)	0.8 (0.031)	25 (0.990)	14.5
11-2	41	AR/BC Inlet Valve Spring	16.6 (0.654)	1.6 (0.063)	45.2 (1.780)	8.5
11-2	45	QS Inlet Valve Spring	28.25 (1.112)	2.25 (0.089)	80.85 (3.183)	8.5
11-2	53	Balancing Piston Spring	47.2 (1.858)	3.2 (0.126)	87 (3.425)	6.5
11-3	12	QS Valve Spring	11.8 (0.464)	0.8 (0.031)	15.9 (0.625)	6.5
11-3	14	Balancing Valve Spring	10.8 (0.425)	0.8 (0.031)	21.1 (0.831)	6.5

Copyright 2017© New York Air Brake. All rights reserved, including industrial property rights applications. New York Air Brake retains any power of disposal, such as copying and transferring.



Knorr-Bremse Group

Page 36 / 73



Maintenance Specification
DB-10C Doc.-No.: NYR-481
Revision: 02 9/18/17 - en

Fig. No.	Ref. No.	Designation	Approx. Outside Dia. mm (inch)	Approx. Wire Dia. mm (inch)	Approx. Free Height mm (inch)	Approx. No. of Turns
11-3	25	Balancing Check Valve Spring	10.5 (0.413)	1.0 (0.039)	22.3 (0.878)	8.0
11-3	28	ER Charging Valve Spring (Blue)	10.4 (0.409)	0.9 (0.036)	22.3 (0.877)	6.5
11-3	29	AR Charging Valve Spring	10.5 (0.413)	1 (0.039)	39.2 (1.543)	11.5
11-3	29A	Balancing Check Valve Spring	10.5 (0.413)	1 (0.039)	39.2 (1.543)	11.5
11-3	30	ER Charging Check Valve Spring	20.3 (0.799)	0.8 (0.031)	33.3 (1.311)	9.5
11-4	4	AR Exhaust (Qty.2) Valve Springs and ER Exhaust Valve Spring	12.6 (0.496)	1.1 (0.043)	29 (1.142)	6.5
11-4	13	Release Valve Portion Spring	13.9 (0.547)	1.4 (0.055)	30 (1.181)	8.5
11-4	20	Release Exhaust Check Valve Spring	10.4 (0.409)	0.8 (0.031)	15 (0.591)	5.5
11-4	22	Release Valve Handle Spring	24 (0.945)	3 (0.118)	41.5 (1.634)	6.5
11-4	26	Release Valve Exhaust Spring	10.4 (0.409)	1.4 (0.055)	33 (1.300)	11.5

7.4 Chokes

1. The size of the chokes in the valve portion is important for proper valve performance. Whenever a portion is disassembled, all chokes must be inspected and cleaned to ensure they are not restricted. When cleaning chokes, the orifice size and shape must not be changed.
2. For proper choke size identification see Table 7-1.
3. Threaded chokes generally can be removed or applied without damage to choke plug or to the thread in the tapped hole. If necessary to drill or tap, all drill chips must be thoroughly blown out of passages.
4. Passages must be checked for cleanliness and blown out if necessary, after chokes are removed. Chokes must then be returned to their proper location.
5. Actual choke diameters must meet the limits specified in Table 7-1.
6. Choke disassembly/assembly can only be done as a special operation. Order complete sub-assembly per parts catalog for replacement of the choke. For replacement of chokes contained in individual parts, order respective parts per parts catalog

Copyright 2017© New York Air Brake. All rights reserved, including industrial property rights applications. New York Air Brake retains any power of disposal, such as copying and transferring.



Knorr-Bremse Group

Page 37 | 73



Maintenance Specification
DB-10C Doc.-No.: NYR-481
Revision: 02 9/18/17 - en

Table 7-2 Choke Identification

Fig. No.	Choke No.	Ref. No.	Designation	Dia. min. / max. mm (inch)
15	C 3.1	26	QS Limiting Valve Charging Choke	0.900/0.960 (0.0354/0.0378)
15	C 4.1	36	Retaining Check Valve Choke	0.700/0.760 (0.0276/0.0299)
15	C 6.1	4	Release Valve Exhaust Control Choke	0.700/0.760 (0.0276/0.0299)
16	C 1.3	60	Stability Choke	0.200/0.225 (0.0079/0.0089)
16	C 1.6	60	Sensitivity Choke	1.300/1.360 (0.0512/0.0535)
16	C 1.8	66	BC Release Choke	2.420/2.460 (0.0945/0.0969)
17	C 1.4	18	Retarded Recharge Choke	1.400/1.460 (0.0551/0.0575)
17	C 1.5	32	ER Charging Check Valve Choke	0.700/0.760 (0.0276/0.0299)
17	C 1.7	26	Balancing Pressure Exhaust Choke	0.400/0.480 (0.0157/0.0189)
17	C 5.1	9	QS Pressure Exhaust Choke	1.000/1.060 (0.0394/0.0417)
18	C 6.2	18	Release Valve Charging Control Choke	0.500/0.530 (0.0197/0.0209)
18	C 6.3	*	Release Valve Reset Control Choke	0.600/0.630 (0.0236/0.0248)

NOTICE

*** NOTE**

This choke is part of a release valve subassembly. It is located either adjacent to the bushing, or it is integrated into the bushing that release valve piston rod (9) fits into. (See Figure 6-4)

7.5 Rubber Parts

1. All rubber parts must be replaced with new parts when reassembling the valve. All items can be identified for ordering purposes per the parts catalog.
2. New rubber parts that have been in storage for more than five years must not be used.
3. The storage area for rubber parts must be cool, dark, and free from dampness and mildew. Since most rubber goods are affected by ozone, they must not be stored near electrical equipment that may generate ozone.

Copyright 2017© New York Air Brake. All rights reserved, including industrial property rights applications.
New York Air Brake retains any power of disposal, such as copying and transferring.



Knorr-Bremse Group

Page 38 / 73



Maintenance Specification	
DB-10C	Doc.-No.: NYR-481
	Revision: 02 9/18/17 - en

7.6 Filters and Accessory Parts

All filters and accessory parts have to be replaced by new parts when reassembling the valves. All items are part of a separate Repair Kit, which has to be ordered per the parts catalog.

Copyright 2017© New York Air Brake. All rights reserved, including industrial property rights applications.
New York Air Brake retains any power of disposal, such as copying and transferring.





Maintenance Specification	
DB-10C	Doc.-No.: NYR-481
	Revision: 02 9/18/17 - en

8 LUBRICATING AND REASSEMBLY

8.1 Lubrication

1. All sliding surfaces and all parts with their respective grooves should be coated with a light film of Dow Corning 55 Silicone Grease. Remove excess grease by wiping.

NOTICE

NOTE

Coat O-Rings and K-Rings with only a light film of grease. Do not apply grease to check valves and diaphragms. Wipe face of new check valves to ensure a contaminant-free surface.

2. During re-assembly of valve portions, only use the Thin Wall Type Mandrel (Fig. 11-13) in order to prevent damage to specific O-Rings.
3. The supply of O-Rings kept on a mandrel must not exceed daily requirements to prevent permanent stretch. In addition, caution must be used to protect against contamination from dirt and foreign matter damaging O-Rings and lubricant.

NOTICE

NOTE

To prevent restriction of small orifices, do not apply grease to the threads of the main piston assembly.





Maintenance Specification	
DB-10C	Doc. No.: NYR-481
	Revision: 02 9/18/17 - en

8.2 Torque Requirements

When reassembling DB-10C Service Portions, cap screws and nuts must be tightened sufficiently to prevent gasket leakage, and yet not so tight as to cause distortion of covers and gaskets. For correct torque values for the Service Portion, refer to Table 8-1 below.

Recommended torque values for cap screws, nuts and threaded bushings are listed in the following tabulation:

Table 8-1 Torque Requirements

FIG. No.	PART NAME & ITEM No.	TORQUE LIMITS IN FOOT POUNDS (Nm)
11-1	Cover Cap Screw (2) & (3)	20 to 24 (28 to 32)
11-1	Threaded Bushing (11) & (19)	10 to 15 (14 to 20)
11-2	Cover Cap Screw (2) & (3)	20 to 24 (28 to 32)
11-2	Threaded Bushing (39) & (46)	10 to 15 (14 to 20)
11-2	Choke (59), (60), (62)	20 to 30 in-lb. (3 to 4)
11-3	Cover Cap Screw (42)	20 to 24 (28 to 32)
11-4	Cover Cap Screw (1)	20 to 24 (28 to 32)
11-4	Hex Nut (17)	5 to 7 (7 to 10)

Copyright 2017© New York Air Brake. All rights reserved, including industrial property rights applications.
 New York Air Brake retains any power of disposal, such as copying and transferring.



Knorr-Bremse Group

Page 41 / 73



Maintenance Specification	
DB-10C	Doc.No.: NYR-481
	Revision: 02 9/18/17 - en

8.3 Assembly of DB-10C Service Portion

8.3.1 DB-10C Service Portion Requirements for Assembly

1. Prior to assembly, make sure that all conditions as prescribed in Mandatory Component Modifications are satisfied.
2. Whenever possible, avoid using dissimilar metal covers or subassemblies.
3. Aluminum bodies **must** receive aluminum covers and subassemblies.
4. Aluminum covers or subassemblies may be used with cast iron bodies if cast iron covers or subassemblies are not available.
5. During assembly, all parts **MUST** fit together easily. Do not "force-fit" parts, as damage to the valve or malfunction may result.
6. Install Knorr K-Rings only in accordance with the instructions given in Fig. 6-1, pg. 29.
7. When inserting K-Ring equipped pistons into their piston cavities, make sure the K-Rings are properly centered on the pistons so as to preclude damage to the sealing surfaces during installation.
8. When placing the covers on the housings of the DB-10C Service Portion, be sure all rubber diaphragms and O-Rings are seated properly in their respective grooves so they are not pinched or damaged when the covers are applied.



CAUTION

IMPROPER OR INCORRECT INSTALLATION OF SPRINGS WILL RESULT IN VALVE MALFUNCTION.

9. Assure that all springs are seated properly, and the correct springs are being installed within the appropriate location.
10. Ensure that all threaded parts are hand tightened before applying a torque with a wrench to preclude cross threading. **For proper torque requirements see Section 8.2 (Table 8-1).**



NOTE

Choke orifices must remain free of obstructions.

Copyright 2017© New York Air Brake. All rights reserved, including industrial property rights applications.
New York Air Brake retains any power of disposal, such as copying and transferring.



Knorr-Bremse Group

Page 42 / 73



Maintenance Specification	
DB-10C	Doc.-No.: NYR-481
	Revision: 02 9/18/17 - en

NOTICE
NOTE
To hold the valve from moving during assembly, it may be beneficial to attach the valve to a suitable holding fixture.

8.3.2 Assembly of DB-10C Release Valve

(Refer to Figure 11-4)

CAUTION
CAUTION
Do not damage sealing surfaces
Do not damage the machined sealing surface on the opposite side of the housing.

NOTICE
NOTE
Prior to assembly, all O-Rings, K-Rings, bushing surfaces and their respective grooves or holes into which they are fitted, should be lubricated lightly with Dow Corning 55 Silicone Grease.

NOTICE
NOTE
Metal to metal surfaces need to be coated with a light film of grease.
Use K-Ring Positioning Tool (Fig. 11-12) and/or tweezers if necessary to assemble parts.
Bottom cover (30) surface should be facing up.
Before inserting all items, make sure the choke size (C6.3 in Figure 6-4) located in the plugged bushing (16) under the release valve piston (9) is free of obstructions.

NOTICE
NOTE
Exercise care to prevent the loss of valve parts.
Use the Thin Wall Type Mandrel (Fig. 11-13) to prevent damage to O-Rings (11 & 12) during assembly.

1. Install two new lightly greased O-Rings (11 & 12) and new lightly greased K-Ring (10) onto piston (9).
2. Insert piston (9) into housing (7).
3. Install new lightly greased O-Ring (15) onto bushing (16).

Copyright 2017© New York Air Brake. All rights reserved, including industrial property rights applications.
New York Air Brake retains any power of disposal, such as copying and transferring.

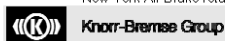



Maintenance Specification

DB-10C Doc.No.: NYR-481
Revision: 02 9/18/17 - en

4. Install spring (13), new check valve (14), bushing (16) and new nut (17) onto piston (9). Hold piston (9) in place with a properly fitting screwdriver, then torque nut (17) to 5-7 ft lbs. (7-10 Nm).
5. Rotate release valve so cover (2) face is up.



CAUTION

Do not damage the valve seat radius of bushing (19).

6. Place new O-Rings (3), new O-Ring (18) and new O-Ring (8) onto top cover (2) face of housing (7).
7. Install new lightly greased O-Ring (18) onto bushing (19).
8. Insert new check valve (21), spring (20) and bushing (19) into housing (7).
9. Insert two stems (6), two new check valves (5) and two springs (4) into housing (7).



NOTE

Portions manufactured before February 2017 had Items 36 (flat washer) and 37 (CID tag) installed with a cap screw (1) as shown in Figure 11-4 to provide a location on the housing for the CID label. The housing now has a machined area for the label.

10. Place cover (2) onto housing (7) and secure in place with cap screws (1). Torque screws (1) to 20-24 ft lbs. (28-32 Nm).
11. Rotate release valve so cover (30) face is up.
12. Install new lightly greased O-ring (3) onto housing (7).
13. Insert new vent flap (31) and new spacer ring (32) into cover (30).
14. Insert pop rivet (33) into spacer ring (32), vent flap (31) and cover (30) and secure in place.
15. Install new lightly greased O-ring (24) onto stem (25).
16. Install new spring (22), spring guide (23), stem (25), spring (26) and lifter (27) into release valve housing (7).
17. Install while holding release valve handle (28) and sleeve (29) in place in cover (30).
18. Place cover (30) onto housing (7) and securing in place with cap screws (1). Torque cap screws (1) to 20-24 ft lbs. (28-32 Nm)

Copyright 2017© New York Air Brake. All rights reserved, including industrial property rights applications.
New York Air Brake retains any power of disposal, such as copying and transferring.



Knorr-Bremse Group

Page 44 / 73



Maintenance Specification	
DB-10C	Doc.No.: NYR-481
	Revision: 02 9/18/17 - en

8.3.3 Assembly of DB-10C Filler Piece

(Refer to Figure 11-3) (Includes parts seen in dotted box at top of drawing)

OLD FILLER PIECE INSTRUCTIONS for P/N I85200/001D Cast Iron Service Portions with S/N A0-XXXXX through S/N D0-XXXXX that have NOT had "E0" modification performed.

NOTICE

NOTE

Use K-Ring Positioning Tool (Fig. 11-15), tweezers and suitable pliers only.

Refer to Fig. 8-1 for proper location of the auxiliary reservoir charging valve (18), the emergency reservoir charging valve (17) and the balancing valve (13).

1. Insert ER stem (17) and new retaining ring (20) into ER hole in cover assembly (1).
2. Install new AR sealing ring (19) into cover assembly (1) and insert stem (18) and new retaining ring (20) into AR hole in cover assembly (1).
3. Insert spring (14), washer (15), and new lightly greased K-Ring (16) onto stem (13) then insert stem (13) and new retaining ring (20) into balancing valve hole in cover assembly (1).
4. Replace remaining parts by following "New Filler Piece Instructions". Disregard steps that include stems (13, 17 and 18) w/associated parts and bushings (21 and 27) with O-Rings (2 and 22).

For P/N I85200/001D Cast Iron Service Portions with S/N A0-XXXXX through S/N C0-XXXXX: Spring (25) with yellow coloring and new filter (26) must be used in step 8.

NEW FILLER PIECE INSTRUCTIONS [for Aluminum Service Portions P/N 775868 and Cast Iron Service Portions P/N I85200/001D starting with S/N E0-XXXXX or that did have the "E0" modification performed]

(Refer to Figure 11-3)

1. Install new vent flap (45) and new spacer ring (46) onto cover assembly (43) using a new pop rivet (47).
2. Place cover assembly (43) side of cover (1) facing up.

Copyright 2017© New York Air Brake. All rights reserved, including industrial property rights applications.
New York Air Brake retains any power of disposal, such as copying and transferring.

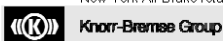



Maintenance Specification

DB-10C Doc.No.: NYR-481
Revision: 02 9/18/17 - en

3. Assemble new O-Rings (36 & 37) onto bushing (38). Insert bushing (38) into cover (1).
4. Assemble new K-Rings (40 & 42) onto piston (41). Insert piston (41), into bushing (38).

NOTICE

NOTE

If necessary, use Quick Service Valve Removal Tool (Fig. 11-5) to install pistons.

5. Place new O-ring (39) onto cover (1).
6. Place spring (14) and washer (15) onto stem (13) and then secure in place with new K-Ring (16). Place stem assembly (13 thru 16) into cover (1).
7. Place two new O-Rings (22) onto bushing (21). Place bushing (21) into cover (1), and place new check valve (23) into bushing (21).

NOTICE

NOTE

To aid in assembly, apply a dab of Dow Corning 55 Silicone Grease to radius end of spring seat (24), (this will help seat, spring, and filter stand upright).

8. Place new spring seat (24) into spring (25). Place new O-ring (2) on the spring side of the new filter (26), then place filter (26) on other end of spring (25). Place parts (24 thru 26) into cover (1).
9. Assemble new O-Ring (2) onto bushing (3). Insert bushing (3) into cover (1).
10. Assemble new K-Rings (4 & 6) and new O-Ring (7) onto piston (5). Insert piston (5) into bushing (3).
11. Assemble new O-Rings (8) onto bushing (9). Insert bushing (9) and new O-Ring (10) into cover (1).
12. Place new check valve (11) on top of bushing (9) (flat side down). Place spring (12) onto check valve (11).
13. Place white plastic stem (17) into cover (1). Assemble two new O-Rings (22) onto OD of bushing (27). Place bushing (27) into cover (1).
14. Place new check valve (23) and spring (28) into bushing (27). Place new O-Ring (2) into cover (1).
15. Place spring (30), new check valve (31), and bushing (32) into cover (1). Place new O-Ring (33) into cover (1).

Copyright 2017© New York Air Brake. All rights reserved, including industrial property rights applications.
New York Air Brake retains any power of disposal, such as copying and transferring.



Knorr-Bremse Group

Page 46 / 73



Maintenance Specification	
DB-10C	Doc.No.: NYR-481
	Revision: 02 9/18/17 - en

16. Place white plastic stem (18) into cover (1). Place new sealing ring (19) into ID of bushing (27) and new O-Rings (22) onto OD of bushing (27). Place bushing (27) into cover (1).
17. Place new check valve (23), new spring seat (24) and spring (29) into bushing (27). Place new O-Ring (2) into cover (1).
18. Assemble new O-Rings (34 & 35) into cover (1).

NOTICE	<p>NOTE</p> <p>It is very important to make sure that springs are not resting on rubber section of check valves (this will cause leakage) before installing cover assembly (43) to filler cover (1). It is also important to ensure that all protruding bore assemblies in filler cover (1) are vertical and line up squarely with adjoining cavities in cover assembly (43).</p> <p>It is recommended that three Guide Pins (Fig. 11-9) be used when installing cover assembly (43) to filler cover (1). Place cover (43) on filler cover (1) and secure with cap screws (44). Torque cap screws (44) to 20-24 ft-lbs (28-32 N-M).</p>
---------------	--

8.3.4 Assembly of DB-10C Housing Assembly

(Refer to Figure 11-2)

1. Place filler piece assembly (58), mounting surface side of housing (6) facing down.

CAUTION	<p>CAUTION</p> <p>DO NOT DAMAGE THE VALVE SEAT RADIUS OF BUSHING (41).</p>
----------------	---

2. Install new lightly greased K-Ring (42) and bushing (41) into housing (6).
3. Insert new O-Ring (40) onto housing (6) on top of valve seat bushing (41).
4. Install new O-Ring (38) onto brass style threaded bushing (37). (See section 7.2)
5. Insert new check valve (10) and spring (39) into housing (6).

Copyright 2017© New York Air Brake. All rights reserved, including industrial property rights applications.
New York Air Brake retains any power of disposal, such as copying and transferring.

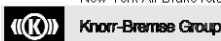



Maintenance Specification

DB-10C Doc.No.: NYR-481
Revision: 02 9/18/17 - en

WARNING

⚠ WARNING PARTS MAY BE INADVERTENTLY EXPELLED BY FORCE OF SPRING. WEAR EYE PROTECTION AND EXERCISE CARE DURING ASSEMBLY. FAILURE TO OBSERVE THESE SAFETY PRECAUTIONS CAN LEAD TO INJURY.

6. Place threaded bushing (37) into housing (6). Use a 1-13/16" socket wrench and torque bushing (37) to 10-15 ft lbs. (14-20 Nm).
7. With filler piece assembly (58) (bottom face) side of housing (6) facing up and back face of housing (6) facing forward, screw chokes (60 & 62) into housing (6). Torque chokes (60 & 62) to 20-30 in lbs. (3-4 Nm).
8. Install new stability choke assembly (59) into place with a suitable Allen wrench and torque to 20-30 in-lbs (3-4 Nm).

CAUTION

⚠ CAUTION DO NOT DAMAGE THE VALVE SEAT RADIUS OF VALVE STEM (45).

9. Install new O-Ring (35) onto stem (45) and new O-Ring (38) onto threaded bushing (46) using K-Ring Positioning Tool (Fig. 11-15).

WARNING

⚠ WARNING PARTS MAY BE INADVERTENTLY EXPELLED BY FORCE OF SPRING (43) IF SPRING GUIDE (44) IS NOT SECURELY LOCKED IN PLACE. SLOWLY REMOVE THE QUICK SERVICE INLET VALVE POSITIONING TOOL (FIG. 11-6) TO CHECK THAT SPRING GUIDE (44) IS SECURELY IN ITS LOCKED POSITION. FAILURE TO OBSERVE THESE SAFETY PRECAUTIONS CAN LEAD TO INJURY.

10. Insert new spring (43) and spring guide (44) into housing (6). Use Quick Service Inlet Valve Positioning Tool (Fig. 11-6) to compress spring guide (44) and new spring (43). Once compressed, lock spring guide (44) in place by rotating it 1/2 turn in either direction.

Copyright 2017© New York Air Brake. All rights reserved, including industrial property rights applications.
New York Air Brake retains any power of disposal, such as copying and transferring.

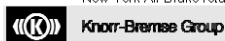



Maintenance Specification

DB-10C Doc.No.: NYR-481
Revision: 02 9/18/17 - en

11. Insert piston stem (45) and new check valve (10) (rubber side of check valve should be visible after installation) into housing (6).
12. Insert threaded bushing (46) into housing (6). Use a 1-13/16" socket wrench and torque bushing (46) to 10-15 ft lbs. (14-20 Nm).
13. Insert new O-Ring (61) and four new O-Rings (34) into their proper grooves in housing (6).

8.3.5 Assembly of Piston Subassembly (47-56)

1. Place new diaphragm (49) with bead facing up, plate (50), nut (51) and key (52) onto piston (48).

 WARNING	WARNING PARTS MAY BE INADVERTENTLY EXPELLED BY FORCE OF SPRING. WEAR EYE PROTECTION AND EXERCISE CARE DURING ASSEMBLY. FAILURE TO OBSERVE THESE SAFETY PRECAUTIONS CAN LEAD TO INJURY.
--	---

2. Place new spring (53), guide (54), guide ring (55) and new retaining ring (56) onto piston assembly (48).
3. To insert new retaining ring (56), push down spring guide (54) against the force of spring (53) by aid of the Retaining Clamp (Fig. 11-8) and a press.
4. Use the Retaining Ring Positioning Tool (Fig. 11-11) to push the new retaining ring (56) into its groove in the piston (48).
5. Ensure that the stem (47) of the piston (48) is still in place. See Figure 8-1.

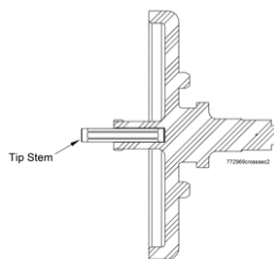

Figure 8-1 Piston Assembly

6. Insert piston subassembly (47-56) into housing (6).

Copyright 2017© New York Air Brake. All rights reserved, including industrial property rights applications.
New York Air Brake retains any power of disposal, such as copying and transferring.



Maintenance Specification	
DB-10C	Doc.No.: NYR-481
	Revision: 02 9/18/17 - en

7. Install new O-Ring (57) onto filler piece assembly (58) and attach filler piece assembly (58) onto housing (6) using cap screws (2). Torque cap screws (2) to 20-24 ft lbs. (28-32 Nm).

8.3.6 Assembly of DB-10C Portions

(Refer to Figure 11-1)

1. Insert choke (36) and new lightly greased O-Ring (35) into housing (6). Proceed to step #2 if not performing the "F0" modification or step #3 if performing the "F0" modification.

For all valve portions before S/N F0-XXXXX that are not having the "F0" modification performed:

- a. Install new lightly greased O-Ring (15) onto threaded bushing (13).
- b. Insert new check valve (18), spring (17), spring guide (16) and threaded bushing (13) into housing (6). Screw threaded bushing (13), using a 1-5/8" socket wrench, into housing (6). See Figure 8-3 for visual identification of threaded bushing (13). Tighten bushing (13) to 10-15 ft lbs. (14-20 Nm).

NOTICE

NOTE

Spacer ring (9) may be made out of different materials that require different assembly procedure step "c" or "d" listed below.

- c. If spacer ring (9) is a steel type, use Spacer Ring Assembly Tool (Fig. 11-11) and push spacer ring (9) carefully into housing (6). Proceed to step "e".

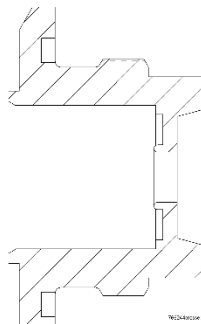

Figure 8-2 Bushing with valve seat (Item 13)

Copyright 2017© New York Air Brake. All rights reserved, including industrial property rights applications.
New York Air Brake retains any power of disposal, such as copying and transferring.



Maintenance Specification

DB-10C Doc.-No.: NYR-481
Revision: 02 9/18/17 - en

- d. If spacer ring (9) is a plastic type, it can be inserted without a tool. Proceed to step "e".
- e. Install new check valve (12), spring guide (10), spacer ring (9), new diaphragm (8) and new spring (7) into housing (6) on top of threaded bushing (13). Proceed to step # 4.

For all valve portions starting with S/N F0-XXXXX or that are having the "F0" modification performed (See section 7.2):

2. Install new lightly greased O-ring (15) onto threaded bushing (14). See Figure 8-2.

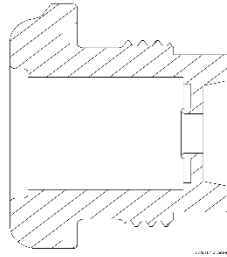

Figure 8-3 Threaded Bushing (item 14) starting at S/N F0-XXXXX

3. Insert new check valve (18), spring (17), spring guide (16) and threaded bushing (14) into housing (6). Screw threaded bushing (14), using a 1-5/8" socket wrench, into housing (6). Tighten bushing (14) to 10-15 ft lbs. (14-20 Nm). Install new check valve (12), spring guide (10), new diaphragm (8) and new spring (7) into housing (6) on top of threaded bushing (11).
4. Insert bushing (26), spring (27), new lightly greased O-Ring (24), two new check valves (23), spring (25), and threaded bushing (22) into housing (6). With a 3/4" socket wrench, torque threaded bushing (22) to 10-15 ft lbs. (14-20 Nm). Install new diaphragm (21), spring guide (20) and new spring (19) into housing (6) on top of threaded bushing (23).
5. For Cast Iron valve portions, P/N I85200/001D, before S/N C0-XXXXX that are not having the "C0" modification performed:
 - Insert new filter (32), retaining ring (31A), new check valve (31) and spring (30) into housing (6). Proceed to step # 7.

Copyright 2017© New York Air Brake. All rights reserved, including industrial property rights applications.
New York Air Brake retains any power of disposal, such as copying and transferring.



Maintenance Specification

DB-10C Doc.No.: NYR-481
Revision: 02 9/18/17 - en

6. For Cast Iron valve portions, P/N I85200/001D, starting with S/N C0-XXXXX or that are having the "C0" modification performed:
 - Insert new filter (32), new check valve (31) and spring (30) into housing (6). Proceed to step # 7.
7. Insert new check valve (26) and new spring (27) into housing (6).
8. Insert exhaust bushing (65) and O-Ring (5) into housing (6).
9. Insert new check valve (12), spring (34), spring guide (10), new diaphragm (21), spring guide (20) and spring (33) into housing (6).
10. Place new lightly greased O-Rings (29), (63), (64) and (5) into their respective grooves on the cover (28) face of housing (6). It is recommended that two alignment pins are used during installation of cover (28). [For Cast Iron cover (28), place new lightly greased O-Ring (66) into designated groove].
11. Place cover (28) onto housing (6) and secure in place with cap screws (2). Torque cap screws (2) to 20-24 ft lbs. (28-32 Nm).
12. Position housing (6) so that release valve mounting is face-up.
13. Insert choke (4) and seven new lightly greased O-Rings (5) into release valve housing (1).
14. Place release valve housing (1) onto DB10B housing (6) and secure together with cap screws (2 and 3). Tighten screws (2 & 3) to 20-24 ft lbs. (28-32 Nm).

8.3.7 Nameplate Identification for DB-10C

1. Check the nameplate of the DB-10C Service Portion. If the data stamped on it is illegible or the nameplate is damaged or missing, the nameplate must be replaced.
2. Replacement nameplates are available by contacting NYAB or a NYAB representative. Replacement nameplates will have an assigned serial number.
3. As an alternative method to step 2 above, a COT&S tag may be attached to DB-10 in place of the nameplate:
 - Warranty information will consist of a bolt-on tag and adhesive label.
 - Adhesive label shall include: repair location, part number, test date and warranty expiration date.
 - Serial prefix (engineering revision) shall be a two letter indicator stamped into the bolt-on tag or a two letter indicator printed on the adhesive tag.
 - No serialization is required

Copyright 2017© New York Air Brake. All rights reserved, including industrial property rights applications.
New York Air Brake retains any power of disposal, such as copying and transferring.



Knorr-Bremse Group

Page 52 / 73



Maintenance Specification	
DB-10C	Doc.No.: NYR-481
	Revision: 02 9/18/17 - en

9 TESTING

1. Cleaned and repaired Service Portions must pass prescribed tests on the A.A.R. standard test rack in accordance with NYAB test instructions.
2. After the DB-10C Service Portion has passed this Code of Tests and has been removed from the test rack, it must be stenciled and a shipping cover must be applied. The shipping cover must not be removed until the portion is ready to be installed on a car.
3. A suitable surface of the Service portion must be stenciled with letters at least ½" high in accordance with Figure 10-1.

10 MATERIAL HANDLING

1. When the Service portion is not attached to the pipe bracket, a special shipping cover and gasket must be fitted to the valve portion for protection against dirt and damage (see Fig. 10-2 and 10-3).
2. These covers and guards must be applied to the Valve Portions as soon as they have passed the Code of Tests on the test rack and must not be removed until the cleaned valve portion is ready to be applied to the rail vehicle. Even then, special precautions must be taken to avoid damaging the parts or getting dirt into the operating portions when applying them.
3. The shipping cover, shown in Fig. 10-3, pg. 56, can be used for all currently A.A.R. approved Service portions.
4. The release valve stem guards, shown in Fig. 10-3, pg. 56, are provided to protect the internal parts from damage.
5. These stem guards must be applied to the release valve stem and held in place by a 3/16" (Nominal Size ø 5 mm) cotter pin before transporting the valve portion.

Copyright 2017© New York Air Brake. All rights reserved, including industrial property rights applications.
New York Air Brake retains any power of disposal, such as copying and transferring.



Knorr-Bremse Group

Page 53 / 73



Maintenance Specification
 DB-10C Doc.-No.: NYR-481
 Revision: 02 9/18/17 - en

Example 1

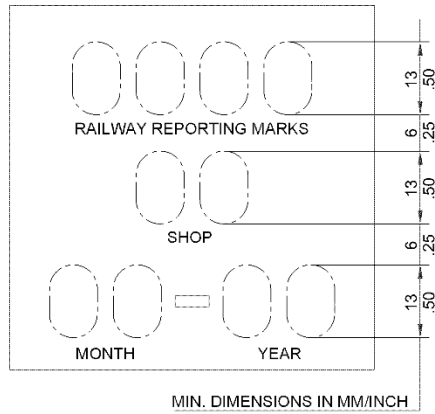

Example 2

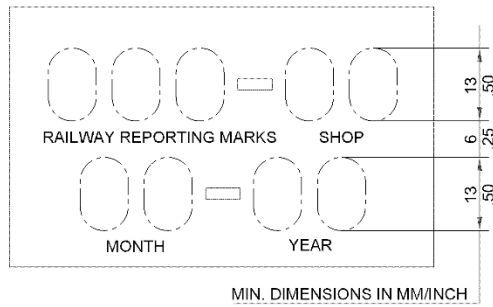

779868LOC5

Figure 10-1 Examples of Valve Portion Stenciling with Required Information

Copyright 2017© New York Air Brake. All rights reserved, including industrial property rights applications.
 New York Air Brake retains any power of disposal, such as copying and transferring.

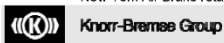



Maintenance Specification

DB-10C	Doc. No. NYR-481
	Revision: 02 9/18/17 - en

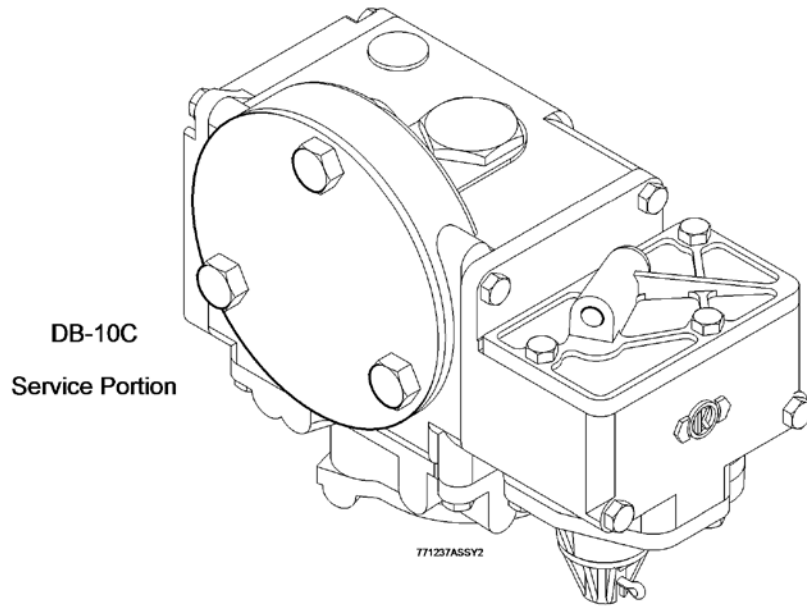

Figure 10-2 DB-10C Service Portion with Shipping Parts (Installed)

Copyright 2017© New York Air Brake. All rights reserved, including industrial property rights applications.
New York Air Brake retains any power of disposal, such as copying and transferring.



Knorr-Bremse Group



Maintenance Specification

DB-10C	Doc. No. NYR-481
	Revision: 02 9/18/17 - en

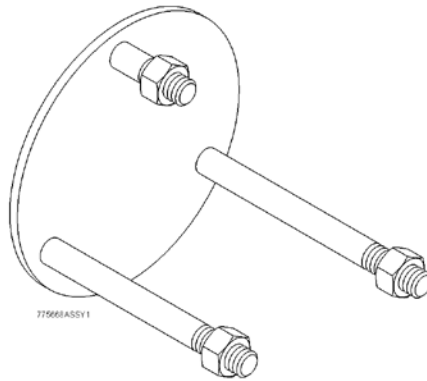

Service Portion

SHIPPING COVER

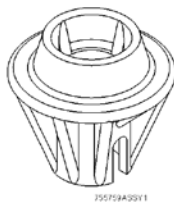

Standard

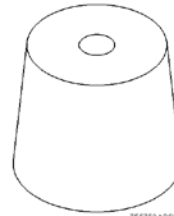

Alternate

RELEASE VALVE STEM GUARDS

Figure 10-3 Shipping Parts

Copyright 2017© New York Air Brake. All rights reserved, including industrial property rights applications.
New York Air Brake retains any power of disposal, such as copying and transferring.



Knorr-Bremse Group



Maintenance Specification
DB-10C Doc.-No.: NYR-481
Revision: 02 9/18/17 - en

11 SUPPORT INFORMATION

11.1 DB-10C Service Portion Parts

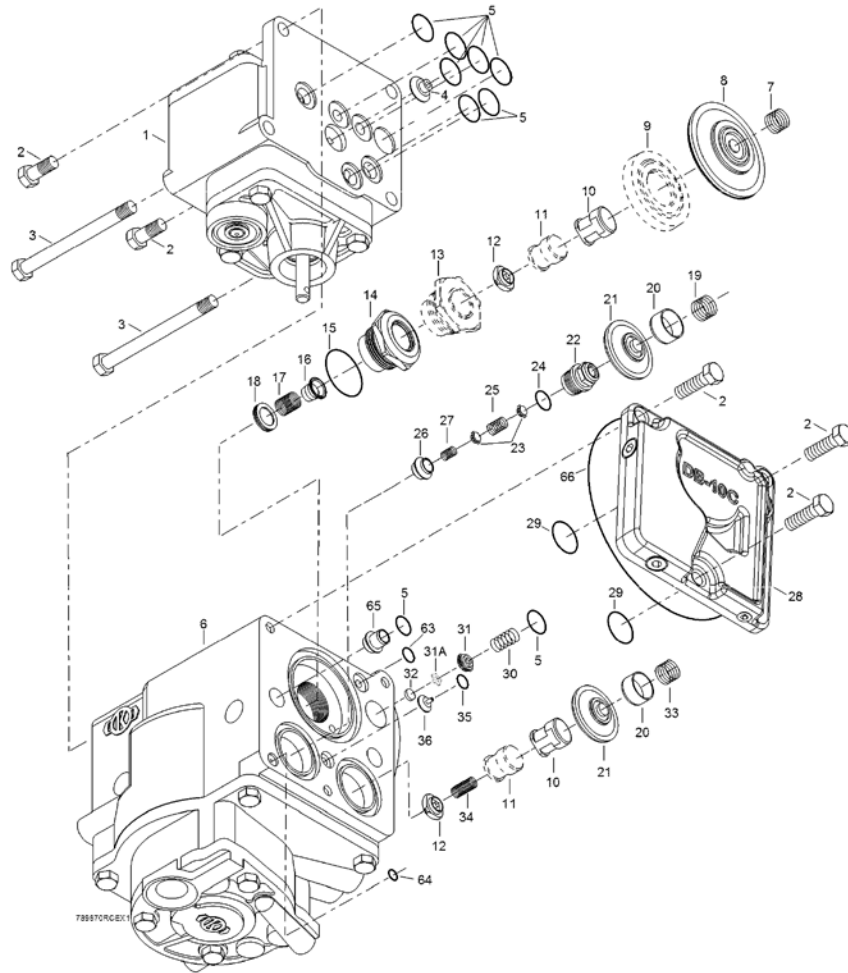
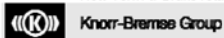

Figure 11-1 DB-10C Service Portion (Exploded View)

Copyright 2017© New York Air Brake. All rights reserved, including industrial property rights applications.
New York Air Brake retains any power of disposal, such as copying and transferring.





Maintenance Specification
 DB-10C Doc.No.: NYR-481
 Revision: 02 9/18/17 - en

KEY for FIGURE 11-1

Item No.	Description
1.	DB10 Release Valve Portion
2.	Hex Head Cap Screw
3.	Hex Head Cap Screw
4.	Release Valve Exhaust Control Choke
5.	O-Ring
6.	DB10B Housing Assembly
7.	Service Accelerated Release Valve Spring
8.	Service Accelerated Release Valve Diaphragm
9.	Spacer Ring (Part deleted starting with S/N F0-XXXXX)
10.	Spring Guide (Used on portions starting w/ S/N J0-XXXXX)
11.	Spring Guide (Used on portions before S/N J0-XXXXX)
12.	Check Valve
13.	Threaded Bushing (Used on portions before S/N F0-XXXXX)
14.	Threaded Bushing (Used on portions starting with S/N F0-XXXXX)
15.	O-Ring
16.	Service Accelerated Release Valve Spring Guide
17.	Back Flow Check Valve Spring
18.	Back Flow Check Valve
19.	Quick Service Limiting Valve Spring
20.	Quick Service Limiting Valve and Emergency Release AR Reduction Valve Spring Guide
21.	Quick Service Limiting Valve and Emergency Release AR Reduction Valve Diaphragm
22.	Threaded Bushing
23.	Check Valve
24.	O-Ring
25.	Quick Service Limiting Valve Spring
26.	Bushing w/Valve Seat and Quick Service Limiting Valve Charging Choke
27.	Spring

Copyright 2017© New York Air Brake. All rights reserved, including industrial property rights applications.
 New York Air Brake retains any power of disposal, such as copying and transferring.

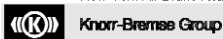



Maintenance Specification

DB-10C Doc.No.: NYR-481
 Revision: 02 9/18/17 - en

Item No.	Description
28.	Side Cover (Cast Iron cover requires Item 66)
29.	O-Ring
30.	Retaining Check Valve Spring
31.	Check Valve
31A.	Self-Locking Retaining Ring (Part deleted starting with S/N C0-XXXXX; remove and discard – do not replace)
32.	Filter
33.	Emergency Release AR Reduction Valve Spring
34.	Emergency Release AR Reduction Check Valve Spring
35.	O-Ring
36.	Retaining Check Valve Choke
63.	O-Ring
64.	O-Ring
65.	Exhaust Bushing
66.	O-Ring (used only with Cast Iron side cover)

Copyright 2017© New York Air Brake. All rights reserved, including industrial property rights applications.
 New York Air Brake retains any power of disposal, such as copying and transferring.



Knorr-Bremse Group

Page 59 / 73



Maintenance Specification

DB-10C	Doc.No.: NYR-481
	Revision: 02 9/18/17 - en

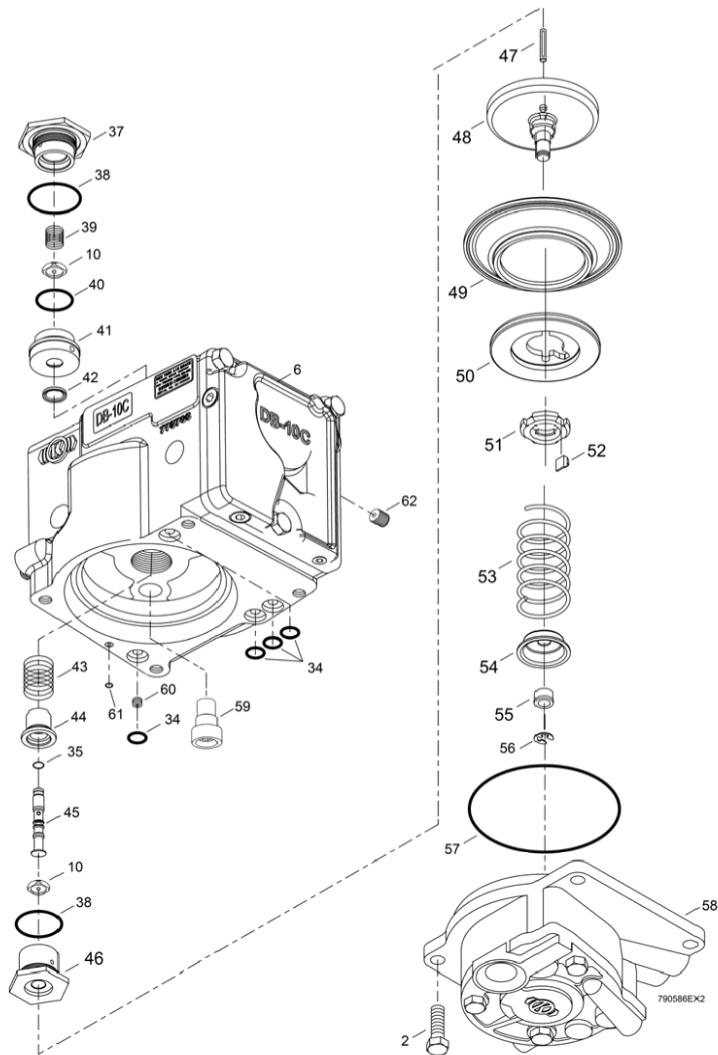

Figure 11-2 DB-10C Housing Assembly (Exploded View)

Copyright 2017© New York Air Brake. All rights reserved, including industrial property rights applications.
 New York Air Brake retains any power of disposal, such as copying and transferring.



Knorr-Bremse Group



Maintenance Specification
 DB-10C Doc.No.: NYR-481
 Revision: 02 9/18/17 - en

KEY for FIGURE 11-2

Item No.	Description
2.	Hex Head Cap Screw
6.	DB10B Housing Assembly
10.	Check Valve
37.	Bushing
38.	O-Ring
39.	Spring
40.	O-Ring
41.	Bushing w/Valve Seat
42.	K-Ring
43.	Quick Service Inlet Valve Spring
44.	Spring Guide
45.	Stem w/Valve Seat
46.	Bushing
47.	Stem
48.	Service Piston
49.	Service Main Diaphragm
50.	Piston Plate
51.	Service Main Hex Nut
52.	Key
53.	Compression Spring
54.	Service Main Piston Spring Guide
55.	Service Main Piston Guide Ring
56.	Retaining Washer
57.	O-Ring
58.	DB10B Filler Piece Assembly
59.	Weeper Choke Assembly
60.	Sensitivity Choke
61.	O-Ring
62.	BC-Release Choke

Copyright 2017© New York Air Brake. All rights reserved, including industrial property rights applications.
 New York Air Brake retains any power of disposal, such as copying and transferring.

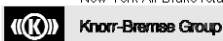



Maintenance Specification
DB-10C Doc.-No.: NYR-481
Revision: 02 9/18/17 - en

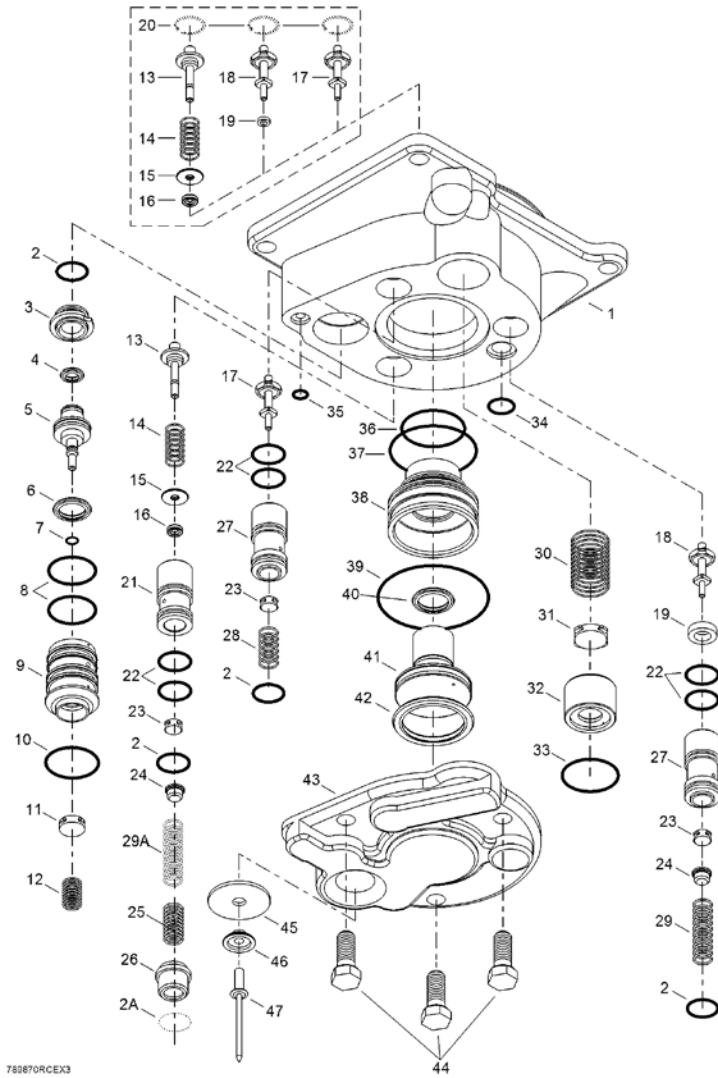

Figure 11-3 DB-10C Filler Piece Assembly (Exploded View)

Copyright 2017© New York Air Brake. All rights reserved, including industrial property rights applications.
New York Air Brake retains any power of disposal, such as copying and transferring.





Maintenance Specification
 DB-10C Doc.No.: NYR-481
 Revision: 02 9/18/17 - en

KEY for FIGURE 11-3

Item No.	Description
1	Cover
2	O-Ring
2A	O-Ring (Used on portions before S/N D0-XXXXX for P/N I85200/001D)
3	Bushing
4	K-Ring
5	Quick Service Valve Piston
6	K-Ring
7	O-Ring
8	O-Ring
9	Bushing w/Valve Seat and Quick Service Pressure Exhaust Choke
10	O-Ring
11	Check Valve
12	Quick Service Valve Spring
13	Balancing Stem
14	Balancing Valve Spring
15	Washer
16	K-Ring
17	ER Charging Stem
18	AR Charging Stem
19	AR-Charging Valve Sealing Ring
20	Retaining Ring (Used on portions before S/N E0-XXXXX)
21	Bushing (For P/N I85200/001D, used on portions starting with S/N E0-XXXXX); (For P/N 775868, used on portions starting with S/N A0-XXXXX)
22	O-Ring
23	Check Valve
24	Spring Seat [For P/N I85200/001D quantity changed from 1 to 2 starting with S/N E0-XXXXX]; (For P/N 775868, quantity is 2 for all configurations)

Copyright 2017© New York Air Brake. All rights reserved, including industrial property rights applications.
 New York Air Brake retains any power of disposal, such as copying and transferring.

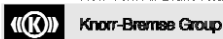



Maintenance Specification
 DB-10C Doc.No.: NYR-481
 Revision: 02 9/18/17 - en

Item No.	Description
25	Balancing Check Valve Spring (For P/N I85200/001D, used on portions starting with E0-XXXXX).
26	Filter (Replaces Bushing w/Exhaust Port for P/N I85200/001D, starting with S/N D0-XXXXX)
27	Bushing (For P/N I85200/001D, used on portions starting with S/N E0-XXXXX); (For P/N 775868, used on portions starting with S/N A0-XXXXX)
28	ER Charging Valve Spring
29	AR Charging Valve Spring
29A	Balancing Check Valve Spring (For P/N I85200/001D, Used on portions prior to D0-XXXXX)
30	ER Charging Check Valve Spring
31	ER Charging Check Valve
32	Bushing w/Valve Seat and ER Charging Check Valve Choke
33	O-Ring
34	O-Ring
35	O-Ring
36	O-Ring
37	O-Ring
38	Bushing
39	O-Ring
40	K-Ring
41	Balancing Piston
42	K-Ring
43	Cover Assembly
44	Hex Head Cap Screw
45	Vent Flap
46	Spacer Ring
47	Pop Rivet

Copyright 2017© New York Air Brake. All rights reserved, including industrial property rights applications.
 New York Air Brake retains any power of disposal, such as copying and transferring.

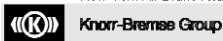



Maintenance Specification
DB-10C Doc.-No.: NYR-481
Revision: 02 9/18/17 - en

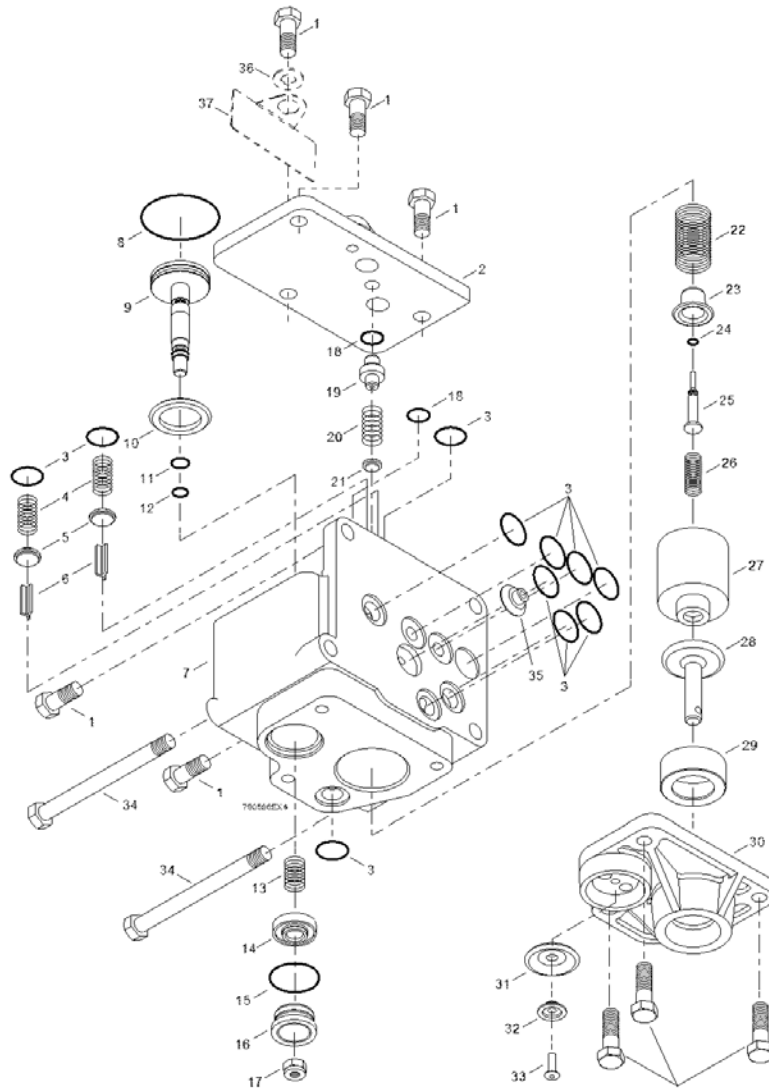
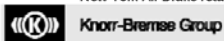

Figure 11-4 DB-10C Release Valve (Exploded View)

Copyright 2017© New York Air Brake. All rights reserved, including industrial property rights applications.
New York Air Brake retains any power of disposal, such as copying and transferring.





Maintenance Specification
 DB-10C Doc.No.: NYR-481
 Revision: 02 9/18/17 - en

KEY for FIGURE 11-4

Item No.	Description
1	Hex Head Cap Screw
2	Upper Cover Assembly
3	O-Ring
4	Exhaust Valve Spring
5	Exhaust AR/ER Check Valve
6	Exhaust Valve Stem
7	DB10A Housing Assembly
8	O-Ring
9	Piston Assembly
10	K-Ring
11	O-Ring
12	O-Ring
13	Release Valve Portion Spring
14	Release Valve Exhaust Check Valve
15	O-Ring
16	Bushing with Valve Seat
17	Hex Locknut
18	O-Ring
19	Bushing w/Valve Seat and Release Valve Charging Control Choke
20	Release Exhaust Check Valve Spring
21	Release Exhaust Check Valve
22	Release Valve Handle Spring
23	Spring Guide
24	O-Ring
25	Release Exhaust Valve Stem
26	Release Exhaust Valve Spring
27	Release Valve Lifter
28	Release Valve Handle
29	Sleeve

Copyright 2017© New York Air Brake. All rights reserved, including industrial property rights applications.
 New York Air Brake retains any power of disposal, such as copying and transferring.

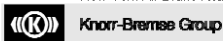



Maintenance Specification

DB-10C Doc.No.: NYR-481
Revision: 02 9/18/17 - en

Item No.	Description
30	DB10A Lower Cover
31	Vent Flap
32	Spacer Ring
33	Pop Rivet
34	Hex Head Cap Screw (same as Item 3 in Figure 11-1)
35	Choke (same as Item 4 in Figure 11-1)
36	Flat Washer
37	AAR CID Tag

Copyright 2017© New York Air Brake. All rights reserved, including industrial property rights applications.
New York Air Brake retains any power of disposal, such as copying and transferring.



Knorr-Bremse Group

Page 67 / 73



Maintenance Specification	
DB-10C	Doc. No.: NYR-481
	Revision: 02 9/18/17 - en

11.2 Special Tools - Drawings

(Refer to Figures 11-5 to 11-16)

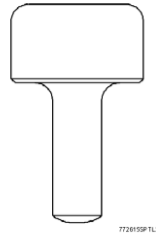

Figure 11-5 Quick Service Valve Removal Tool (P/N 772615)

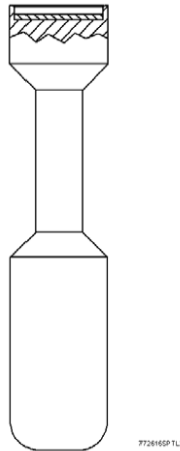

Figure 11-6 Quick Service Inlet Valve Positioning Tool (P/N 772616)

Copyright 2017© New York Air Brake. All rights reserved, including industrial property rights applications.
New York Air Brake retains any power of disposal, such as copying and transferring.



Knorr-Bremse Group

Page 68 / 73



Maintenance Specification	
DB-10C	Doc.-No.: NYR-481
	Revision: 02 9/18/17 - en

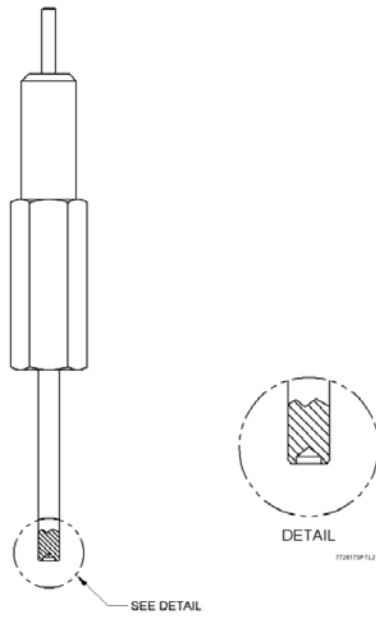

Figure 11-7 Special Hand Drive Pin (P/N 772617)

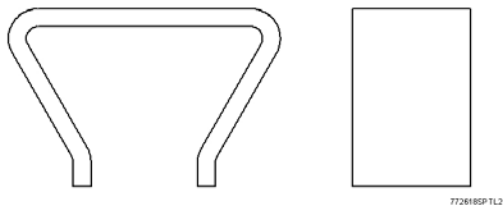

Figure 11-8 Retaining Clamp (P/N 772618)

Copyright 2017© New York Air Brake. All rights reserved, including industrial property rights applications.
New York Air Brake retains any power of disposal, such as copying and transferring.



Knorr-Bremse Group



Maintenance Specification	
DB-10C	Doc.No.: NYR-481
	Revision: 02 9/18/17 - en

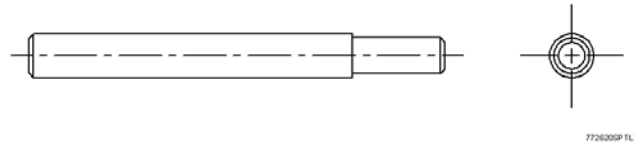

Figure 11-9 Guide Pin (P/N 772620)



Figure 11-10 Bushing Extractor (P/N 772624)

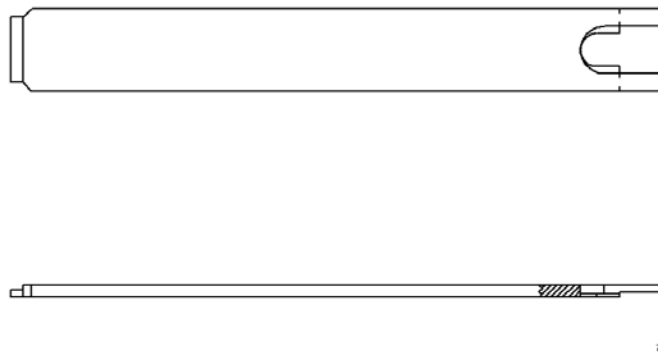

Figure 11-11 Retaining Ring Positioning Tool (P/N 772625)

Copyright 2017© New York Air Brake. All rights reserved, including industrial property rights applications.
New York Air Brake retains any power of disposal, such as copying and transferring.



Knorr-Bremse Group



Maintenance Specification	
DB-10C	Doc-No.: NYR-481
	Revision: 02 9/18/17 - en

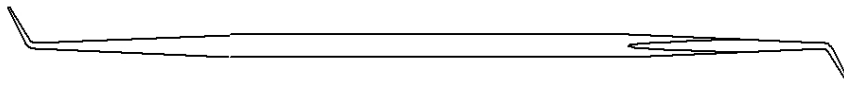
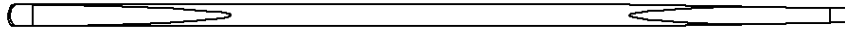

772626SP TL2

Figure 11-12 K-Ring Positioning Tool (P/N 772626)

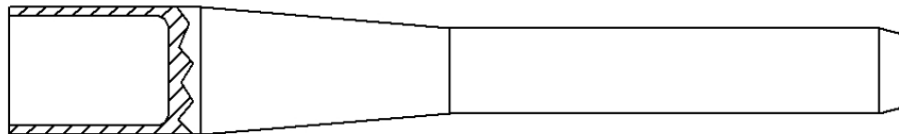

772628SPTL2

Figure 11-13 Thin Wall Type Mandrel (P/N 772628)

Copyright 2017© New York Air Brake. All rights reserved, including industrial property rights applications.
New York Air Brake retains any power of disposal, such as copying and transferring.



Knorr-Bremse Group

Page 71 / 73



Maintenance Specification
DB-10C Doc.-No.: NYR-481
Revision: 02 9/18/17 - en

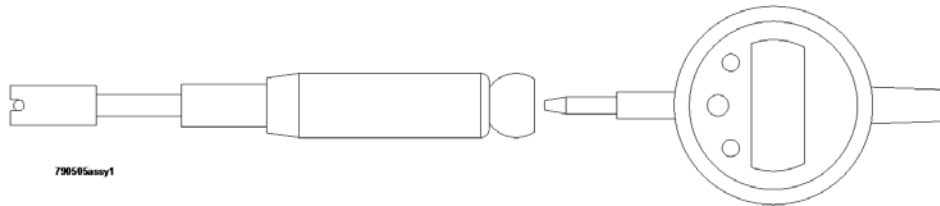

Figure 11-14 12mm Bore Gage (P/N 790505)

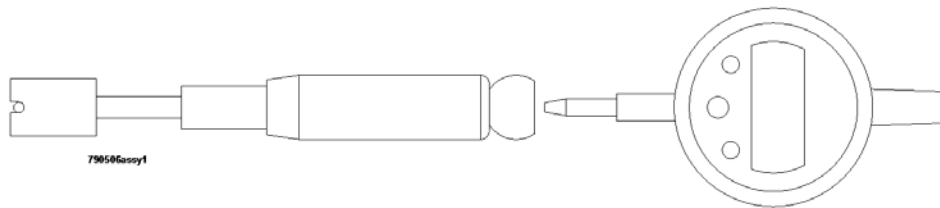

Figure 11-15 17mm Bore Gage (P/N 790506)

Copyright 2017© New York Air Brake. All rights reserved, including industrial property rights applications.
New York Air Brake retains any power of disposal, such as copying and transferring.





Maintenance Specification	
DB-10C	Doc.No.: NYR-481
	Revision: 02 9/18/17 - en

11.3 Abbreviations and Acronyms

AAR.....	ASSOCIATION of AMERICAN RAILROADS
ANSI.....	AMERICAN NATIONAL STANDARDS INSTITUTE
Approx.....	APPROXIMATELY
AR.....	AUXILIARY RESERVOIR
BC.....	BRAKE CYLINDER
CCD	CAR CONTROL DEVICE
CVM	CONTROL VALVE MODULE
DIA	DIAMETER
e.g.	For Example
ER	EMERGENCY RESERVOIR
ESD.....	ELECTROSTATIC DISCHARGE
FCM	FUNCTIONAL CONTROL MODULE
Fig.....	Figure
FT-LBS.....	FOOT POUNDS
IN.....	INCH
IN-LBS.....	INCH POUNDS
LED	LIGHT EMITTING DIODE
MAX.....	MAXIMUM
MIN	MINIMUM
MM	MILLIMETER
No.	NUMBER
Nm	NEWTON METER
NYAB	NEW YORK AIR BRAKE
PCB.....	PRINTED CIRCUIT BOARD
PMM.....	POWER MANAGEMENT MODULE
P/N	PART NUMBER
POV	PILOT OPERATED VALVE
PSI	POUNDS PER SQUARE INCH
PSM	PRESSURE SENSING MODULE
QS.....	QUICK SERVICE
S/N.....	SERIAL NUMBER

Copyright 2017© New York Air Brake. All rights reserved, including industrial property rights applications.
New York Air Brake retains any power of disposal, such as copying and transferring.

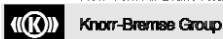

**C.3: Maintenance Specification, DB20 and DB20L Emergency Portions P/N
I85177/001D, I85177/001L, 775871, 775872, NYR-429, Rev 10 11-27-17-en**

Rail Vehicle Systems

.....
.....
NYR-429

Rev 10 11-27-17 - en
.....

.....
Maintenance Specification

DB20 and DB20L Emergency Portions
P/N I85177/001D, I85177/001L, 775871, 775872

NEW YORK AIR BRAKE 



Maintenance Specification	
DB20 and DB20L	Doc.No.: NYR-429
Emergency Portions	Revision: 10 11/27/17 - en

Contact Address

New York Air Brake
748 Starbuck Avenue
Watertown, NY 13601
USA
Phone: +1 315 786 5200
Fax: +1 315 786 5676
www.nyab.com

Copyright 2017© NYAB. All rights reserved, including industrial property rights applications.
NYAB retains any power of disposal, such as copying and transferring.



Knorr-Bremse Group



Maintenance Specification
DB20 and DB20L Doc-No: NYR-429
Emergency Portions Revision: 10 11/27/17 - en

Revision History

Rev	Date	Name	Para	Description of change
01	09/18/2000		All	Original Issue
02	10/12/2005			See highlighted areas
03	1/8/2013	J. Shippee	Figure 11-1; Section 7.2; Figure 11-2; Section 11.3; Section 6.3; Section 8.3.5; All	Add Items 75 and 76; Added J0 and K0 config. upgrades; Updated illustration; Added Abbreviation/Acronym List; Added steps to remove/discard O-Rings; Added specs for COT&S tag; Reformatted document
04	12/16/13	J. Shippee	Page 2; Section 4.2; Section 5; Section 6.3.3; Section 7.2; Section 8.1; Section 8.2; Section 8.3.3; Section 8.3.4; Section 11.	Added Confidentiality statement; Added gage; Removed brake cylinder lubricant; Reformatted section; Corrected item #s in step 1; Added gaging instructions; Removed items 4 & 5 (brake cylinder lubricant instructions); revised 1 st Note; Corrected references in Note; Loctite 242 was Loctite 222; added 'and piston (17)'; Removed 'and plug (13)' from step 1; corrected item #s in steps 1 & 2; Table 11-1-Corrected last four item #s; Added Gage Drawing.
05	1/30/14	J. Jennings	Pg. 53 Section 9	Added Test Code NYT-1698-S
06	5/5/14	J. Shippee	All Section 8.3.1	P/N I85177/001D was 769141, P/N I85177/001L was 769143. Updated guidelines on use of dissimilar metals during repair.
07	6/17/15	J. Shippee	Section 7.2 Figure 11-2 All	Updated for composite piston upgrade. Added Items 74, 75 and 76. Revised spring guidelines to 100% replacement.
08	11/10/15	J. Shippee	All	Reverted spring replacement guidelines back to Rev. 06.
09	9/12/17	L. Vaughn	7.2 (5a)	Added step to replace piston; Removed 'FO' configuration step.
10	11/27/17	J. Shippee	Sec. 6, 7 & 8	Added references to NYS-143 Vibration Upgrade (Inshot Piston Assembly)

The original document was issued in English language.

Copyright 2017© NYAB. All rights reserved, including industrial property rights applications.
NYAB retains any power of disposal, such as copying and transferring.



Knorr-Bremse Group

Page 3 / 71



Maintenance Specification
 DB20 and DB20L Doc-No: NYR-429
 Emergency Portions Revision: 10 11/27/17 - en

Table of Contents

1. GENERAL INFORMATION	7
1.1 Introduction	7
1.2 Technical Changes	7
1.3 Target Group for this Document	7
1.4 Referenced Documents	8
1.5 Danger, Warning, Caution, and Note (Notice) Messages	8
2. PRODUCT IDENTIFICATION	10
3. SAFETY AWARENESS	16
3.1 General Safety Awareness	16
4. TOOLS REQUIRED	17
4.1 Standard Tools	17
4.2 Special Tools	17
5. ADHESIVES, LUBRICANTS, SEALANTS, AND SOLVENTS	18
5.1 Lubricants	18
5.2 Sealants	18
6. DISASSEMBLY	19
6.1 Cleaning	19
6.2 General Requirements	19
6.3 Disassembly (DB20 and DB20L Emergency Portions)	20
7. CLEANING, INSPECTING, AND REPAIRING	31
7.1 Cleaning	31
7.2 Inspecting	32
7.3 Springs	36
7.4 Chokes	37
7.5 Rubber Parts	38
8. LUBRICATING AND REASSEMBLY	40
8.1 Lubrication	40
8.2 Torque Requirements – DB-20 and DB-20L Emerg. Portions	41
8.3 Assembly of DB20 and DB20L Emergency Portions	42

Copyright 2017© NYAB. All rights reserved, including industrial property rights applications.
 NYAB retains any power of disposal, such as copying and transferring.



Knorr-Bremse Group

Page 4 / 71



Maintenance Specification
DB20 and DB20L Doc-No: NYR-429
Emergency Portions Revision: 10 11/27/17 - en

9 TESTING	50
10 MATERIAL HANDLING	50
11 SUPPORT INFORMATION	54
11.1 DB20 and DB20L Emergency Portion Parts	54
11.2 Special Tools – Drawings	64
11.3 Abbreviations and Acronyms	71

Copyright 2017© NYAB. All rights reserved, including industrial property rights applications.
NYAB retains any power of disposal, such as copying and transferring.



Knorr-Bremse Group

Page 5 / 71



Maintenance Specification
 DB20 and DB20L Doc-No.: NYR-429
 Emergency Portions Revision: 10 11/27/17 - en

List of Figures

Figure 2-1 DB-60 Control Valve Operating Portions and Double-Sided Pipe Bracket 11
 Figure 2-2 DB-60L Control Valve Operating Portions and Double-Sided Pipe Bracket 12
 Figure 2-3 DB-60 Control Valve Operating Portions and Single-Sided Pipe Bracket..... 13
 Figure 2-4 Instructions for DB20 and DB20L Emergency Portion Identification 14
 Figure 6-1 Removal and Installation Instructions for KNORR K-Rings (outer lip seal)..... 28
 Figure 6-2 DB20 and DB20L Emergency Portion (Assembly View) 29
 Figure 6-3 DB20 and DB20L Emergency Portion (Assembly View) 30
 Figure 7-1 Valve Seat (Item # 9 in Figure 11-1)..... 36
 Figure 10-1 Examples of Valve Portion Stenciling with Required Information..... 51
 Figure 10-2 DB20 Emergency Portion with Shipping Cover Installed..... 52
 Figure 10-3 DB20 Emergency Portion Shipping Cover..... 53
 Figure 11-1 DB20 and DB20L Emergency Portion-Top and Side Cover Surfaces 54
 Figure 11-2 DB20 and DB20L Emergency Portion-Front Cover Surface 58
 Figure 11-3 DB20 and DB20L Emergency Portion - Side Cover Assembly 61
 Figure 11-4 Special Hand Drive Pin (P/N 772617) 64
 Figure 11-5 Guide Pin (P/N 772620)..... 65
 Figure 11-6 Pin-Type Fixture (Assembly) (P/N 772621) 65
 Figure 11-7 Pin-Type Fixture (Associated Parts) (P/N 773808) 66
 Figure 11-8 Retaining Ring Positioning Tool (P/N 772625) 67
 Figure 11-9 K-Ring Positioning Tool (P/N 772626)..... 67
 Figure 11-10 Guide Ring Assembly Tool (Assembly) (P/N 772627)..... 68
 Figure 11-11 Guide Ring Assembly Tool Body (P/N 773810) 68
 Figure 11-12 Guide Ring Assembly Tool Shaft and Bushing (P/N 773811 and 773812) 69
 Figure 11-13 Thin-Wall Type Mandrel (P/N 772628) 69
 Figure 11-14 6mm Bore Gage (P/N 790504)..... 70

List of Tables

Table 1-1 Referenced Documents 8
 Table 7-1 Choke Identification..... 38
 Table 8-1 Torque Requirements 41
 Table 11-1 Potential 100% Replacement Parts 63

Copyright 2017© NYAB. All rights reserved, including industrial property rights applications.
 NYAB retains any power of disposal, such as copying and transferring.



Knorr-Bremse Group



Maintenance Specification
DB20 and DB20L Doc-No: NYR-429
Emergency Portions Revision: 10 11/27/17 - en

1. GENERAL INFORMATION

1.1 Introduction

This description contains particulars specific to the DB20 and DB20L Emergency Portions P/N I85177/001D, I85177/001L, 775871, and 775872. This document defines the various procedures and information required to disassemble, clean, inspect, and reassemble the Emergency Portions.



DANGER

PLEASE READ THIS DOCUMENT CAREFULLY FROM START TO FINISH ENSURING THE SAFETY OF OPERATION AND TO AVOID PERSONAL INJURIES AND DAMAGE TO EQUIPMENT.

1.2 Technical Changes

NYAB reserves the right to change the equipment or this document at any time without giving special notice.

1.3 Target Group for this Document

This document is intended for use by trained service technicians who:

- have the skill, experience, safety awareness and professional ability:
 - to remove and install the equipment,
 - to inspect, maintain and debug the equipment,
- have read and understood this document from start to finish, and
- are familiar with the safety codes and accident prevention regulations for these activities.



NOTE

This document will be useful to other target groups as well, e.g. project engineers.
However, it does not claim to provide complete information for such target groups.

Copyright 2017© NYAB. All rights reserved, including industrial property rights applications.
NYAB retains any power of disposal, such as copying and transferring.



Knorr-Bremse Group

Page 7 / 71



Maintenance Specification
 DB20 and DB20L Doc.No.: NYR-429
 Emergency Portions Revision: 10 11/27/17 - en

1.4 Referenced Documents

Table 1-1 Referenced Documents

Doc. ID	Doc. No	Title
1	PC-769141	Parts Catalog (DB20 Cast Iron)
2	PC-769143	Parts Catalog (DB20L Cast Iron)
3	PC-775871	Parts Catalog (DB20 Aluminum)
4	PC-775872	Parts Catalog (DB20L Aluminum)
5	NYT-1200-C	Code of Tests, DB-60 and DB-60L Control Valve Portions
6	NYT-1698-S	Test Code, DB20 & DB20L Emergency Portions
7	IP-175	Repair Track Maintenance, DB-60 Type Freight Brake Equipment
8	769141	Assembly Drawing (DB20 Cast Iron)
9	769143	Assembly Drawing (DB20L Cast Iron)
10	775871	Assembly Drawing (DB20 Aluminum)
11	775872	Assembly Drawing (DB20L Aluminum)
12	775871-SP	Serial Prefix Log (DB20 Aluminum)
13	775872-SP	Serial Prefix Log (DB20L Aluminum)
14	769141-SP	Serial Prefix Log (DB20 Cast Iron)
15	769143-SP	Serial Prefix Log (DB20L Cast Iron)
16	NYS-143	Conversion of DB10 and DB20/DB20L (Aluminum) to include Vibration Upgrade
17	794399	DB20 Vibration Kit
18	794401	DB20L Vibration Kit

1.5 Danger, Warning, Caution, and Note (Notice) Messages

The  symbols indicate that important personal safety information follows. Carefully read and understand each safety related text message and apply the message to the operation and maintenance of the system as defined in the safety alert message.

Copyright 2017© NYAB. All rights reserved, including industrial property rights applications.
 NYAB retains any power of disposal, such as copying and transferring.



Knorr-Bremse Group

Page 8 / 71



Maintenance Specification
DB20 and DB20L Doc-No: NYR-429
Emergency Portions Revision: 10 11/27/17 - en

The following are definitions associated with the different safety alert message categories.

The words DANGER, WARNING, and CAUTION are used to identify levels of hazard seriousness for the safety of the personnel and the equipment.

The word DANGER is used to signify an immediate hazard and is used throughout this manual in the following manner:

	DANGER Indicates an imminently hazardous situation, which if not avoided, will result in death or serious injury. This word is to be limited to the most extreme situations.
--	--

The word WARNING is used to signify hazards or unsafe practices and is used throughout this manual in the following manner:

	WARNING Failure to comply with these instructions may lead to irreversible physical injuries which may have fatal consequences.
--	---

The word CAUTION just like the word WARNING is used to signify hazards or unsafe practice in addition to equipment damage and is used throughout this manual in the following manner:

	CAUTION Failure to comply with these instructions may lead to personal injuries and/or to damage to the unit or the environment.
--	--

The NOTE (NOTICE) messages are used throughout this manual in the following manner:

	NOTE Notes do not contain any messages relevant to safety. Notes contain useful hints and additional information used to highlight suggestions which will result in enhanced installation, reliability, or operation.
--	--

Safety messages/notes have a specific structure which is explained here for DANGER (This also applies to WARNINGS and CAUTIONS):

	DANGER Source of the danger Consequences of the danger Remedial measures
--	--

Copyright 2017© NYAB. All rights reserved, including industrial property rights applications.
NYAB retains any power of disposal, such as copying and transferring.



Maintenance Specification	
DB20 and DB20L	Doc-No: NYR-429
Emergency Portions	Revision: 10 11/27/17 - en

2 PRODUCT IDENTIFICATION

2.1 Serial Prefix Identification

The DB20 and 20L Emergency Portions have a nameplate that contains a serial number made up of Alpha and Numeric characters.

- The prefix characters of the serial number are an alpha/numeric combination located before the numeric characters. They identify the original manufacture revision level (ex: first rev. level starts with "A0", second rev. level is "B0", etc.).
- The numeric characters identify the valve production number (this number runs consecutively starting with 00001).
- The suffix characters (if present), are an alpha/numeric combination and are located after the numeric characters. They identify the revision level of modifications, performed after original manufacture (ex.: B0-00789-F0). This suffix is added by the facility that performs the modifications.

The nameplate on the DB20 and 20L Emergency Portions also contains a part number made up of numeric characters.

- I85177/001D and I85177/001L were made as either all cast iron or cast iron with aluminum covers before S/N F0-XXXXX. Starting with S/N F0-XXXXX they were made as all cast iron including the covers.
- 775871 and 775872 are made as all aluminum including the covers.

Figure 2-1 Shows a 'Front' and 'Rear' view of a DB-60 control valve with a conventional style pipe bracket. It consists of a DB10 (Service Portion), DB20 (Emergency Portion), and a DB30 pipe bracket. The rear view shows the port connections for the car piping.

Figure 2-2 Shows a 'Front' and 'Rear' view of a DB-60L control valve with a conventional style pipe bracket. It consists of a DB10 (Service Portion), DB20L (Emergency Portion), and a DB30L pipe bracket. The rear view shows the port connections for the car piping.

Figure 2-3 Shows a 'Front' and 'Rear' view of a DB-60 control valve with a single sided pipe bracket. It consists of a DB10 (Service Portion), DB20 (Emergency Portion), and a Single Sided DB30S pipe bracket. The rear view shows the port connections for the car piping. The DB-60SL version would contain a DB20L emergency portion in place of the DB20, and a DB30SL single sided pipe bracket in place of the DB30S single sided pipe bracket.

Figure 2-4 Shows a DB20 emergency portion and points out the differences between a DB20 and DB20L Emergency Portion. It also shows how to identify early version valves (those that do not have the number "1" cast into them) which must be modified to remove the spill over check valve (refer to Section 7.2).

Copyright 2017© NYAB. All rights reserved, including industrial property rights applications.
NYAB retains any power of disposal, such as copying and transferring.





Maintenance Specification
 DB20 and DB20L Doc.-No.: NYR-429
 Emergency Portions Revision: 10 11/27/17 - en

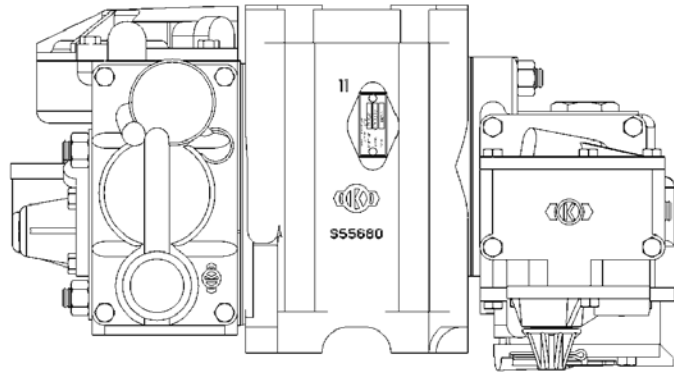

DB-20
Emergency Portion

DB-30
Pipe Bracket

DB-10
Service Portion

Front View

776105AS5Y1

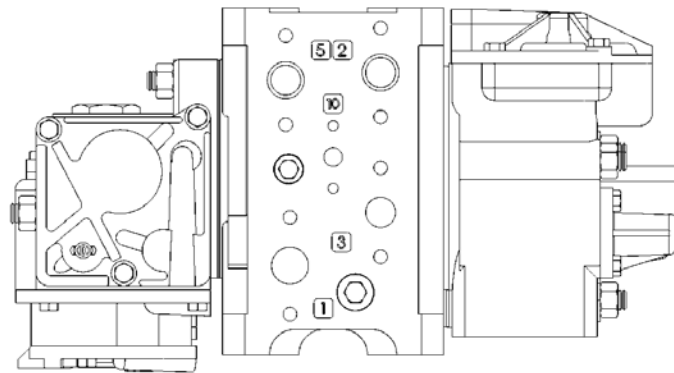

DB-10
Service Portion

DB-30
Pipe Bracket

DB-20
Emergency Portion

Rear View

776105AS5Y2

Figure 2-1 DB-60 Control Valve Operating Portions and Double-Sided Pipe Bracket

Copyright 2017© NYAB. All rights reserved, including industrial property rights applications.
 NYAB retains any power of disposal, such as copying and transferring.



Knorr-Bremse Group



Maintenance Specification
 DB20 and DB20L Doc.-No.: NYR-429
 Emergency Portions Revision: 10 11/27/17 - en

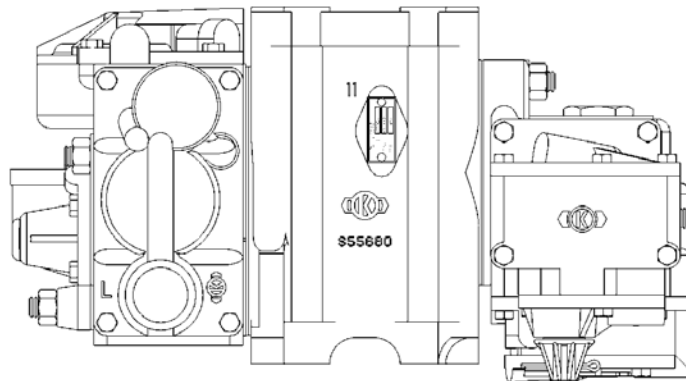

DB-20L Emergency Portion DB-30L Pipe Bracket DB-10 Service Portion

Front View

776106AS2Y1

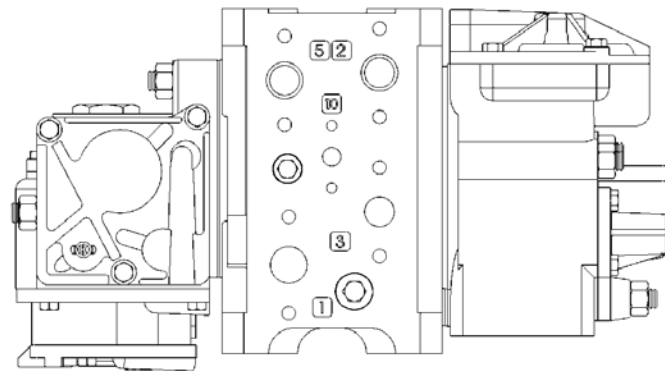

DB-10 Service Portion DB-30L Pipe Bracket DB-20L Emergency Portion

Rear View

776106AS2Y2

Figure 2-2 DB-60L Control Valve Operating Portions and Double-Sided Pipe Bracket

Copyright 2017© NYAB. All rights reserved, including industrial property rights applications.
 NYAB retains any power of disposal, such as copying and transferring.

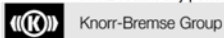



Maintenance Specification
 DB20 and DB20L Doc.-No.: NYR-429
 Emergency Portions Revision: 10 11/27/17 - en

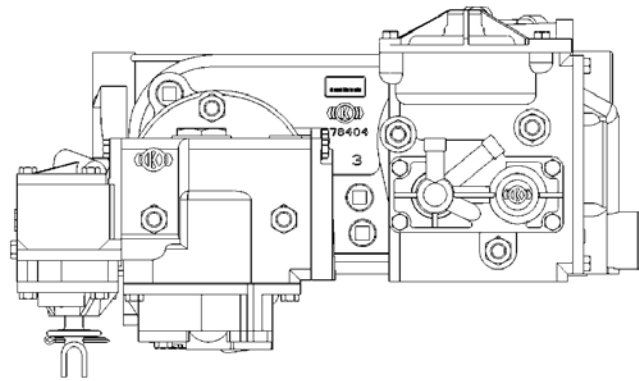

DB-10
Service Portion

DB-30S
Single Sided
Pipe Bracket

DB-20
Emergency Portion

Front View

773616ASV1

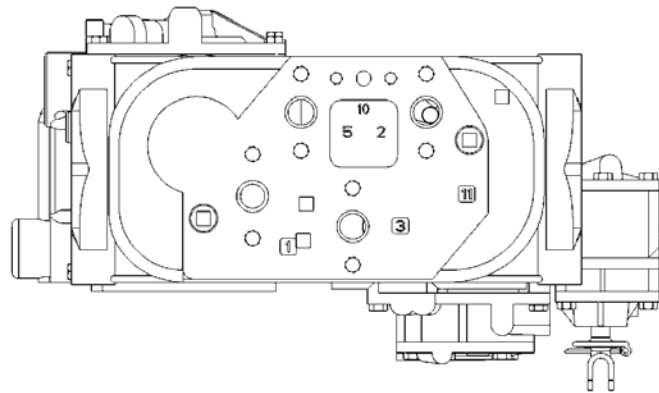

DB-20
Emergency Portion

DB-30S
Single Sided
Pipe Bracket

DB-10
Service Portion

Rear View

773616ASV2

Figure 2-3 DB-60 Control Valve Operating Portions and Single-Sided Pipe Bracket

Copyright 2017© NYAB. All rights reserved, including industrial property rights applications.
 NYAB retains any power of disposal, such as copying and transferring.



Knorr-Bremse Group

Page 13 / 71



Maintenance Specification
DB20 and DB20L Doc.-No.: NYR-429
Emergency Portions Revision: 10 11/27/17 - en

The numeral '1' identifies all
Emergency Portions without
a Spill Over Check Valve.

The letter 'N' on the top cover
has no significance.

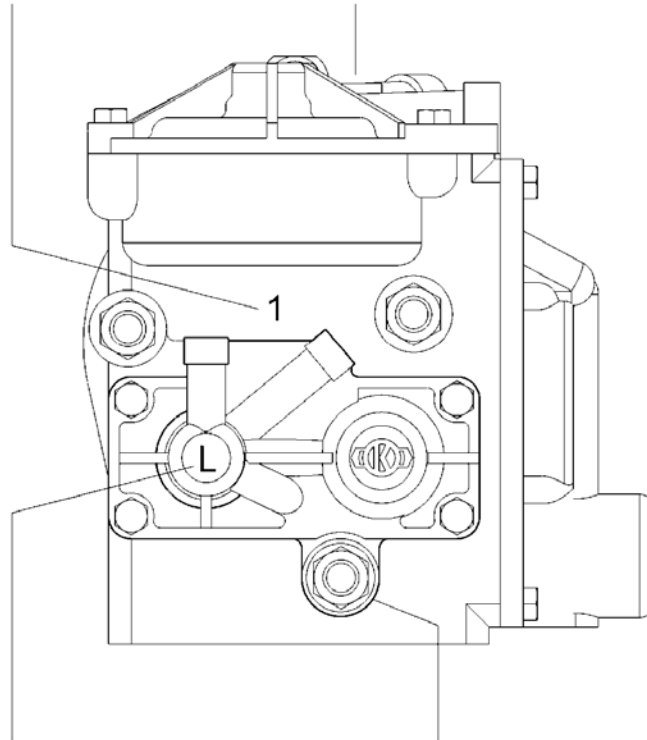

DB-20L Emergency Portions
are identified by the letter 'L'
on both the front and side covers.

DB-20L Front cover contains a
'boss' (extended projection) to
accommodate the longer
Emergency portion mounting stud.

769143LOC1

Figure 2-4 Instructions for DB20 and DB20L Emergency Portion Identification

Copyright 2017© NYAB. All rights reserved, including industrial property rights applications.
NYAB retains any power of disposal, such as copying and transferring.



Knorr-Bremse Group

Page 14 / 71



Maintenance Specification	
DB20 and DB20L	Doc-No: NYR-429
Emergency Portions	Revision: 10 11/27/17 - en

2.2 Product Structure

1. The DB20 or DB20L Emergency Portion consists of housing (29), and covers (2, 34 and 67) with their interior parts (Figures 6-2 and 6-3) and (Figures 11-1, 11-2 and 11-3).
2. The Main Housing Assembly (29) (Figure 11-1), contains the following sub-components: main piston system inshot valve, emergency accelerated release valve and the vent valve, which is also part of the valve combination high pressure vent valve (Figures 10-3 and 11-1). Housings without the numeral '1' (Figure 2-4) also contain a spill over check valve (Figure 6-2).
3. The top cover subassembly (2) (Figure 11-1) contains the accelerated application sensor valve (6) (Figure 11-1), which is also part of the main piston system (Figure 6-2).
4. The side cover subassembly (34) (Figure 11-1) contains the emergency accelerated release valve and the accelerated application valve (Figures 6-2 and 6-3).
5. The front cover subassembly (DB20) and (DB20L) (67) (Figure 11-2) contains the high pressure valve, which is also part of the valve combination high pressure vent valve (Figure 6-3).

Copyright 2017© NYAB. All rights reserved, including industrial property rights applications.
NYAB retains any power of disposal, such as copying and transferring.



Knorr-Bremse Group

Page 15 / 71



3 SAFETY AWARENESS

3.1 General Safety Awareness

1. Observe all rules and regulations where the equipment is being used. Whenever there is a conflict between the instructions in this manual and the instructions of the user, the rules and regulations of the user will govern.
2. De-pressurize air system before loosening connections or components. Before removing any component from its mountings, the train must be safely parked. To prevent personal injury, all main reservoir, brake supply reservoir, and brake cylinder air pressure on the affected vehicle must be vented.
3. "Bottled" up air under pressure (even though air supply is cut off) may cause gaskets and/or particles of dirt to become airborne and sound levels to increase when any component part is removed from the equipment arrangement. Personal eye and ear protection must be worn and care taken to avoid possible injury when performing any work on these component parts.
4. The use of an air jet, which must be less than 30 PSI, to blow parts clean or to blow them dry after being cleaned with a solvent, will cause particles of dirt and/or droplets of the cleaning solvent to be airborne. These particles and droplets may cause skin and /or eye irritation. Personal eye protection must be worn to protect the eyes from possible injury. When using an air jet, do not direct it toward another person.
5. If degreasing fluids are used for cleaning purposes, the current local safety regulations, as well as the safety precautionary statements of the manufacturer of the cleaning agent, must be adhered to. Otherwise, physical harm could result from the inhalation of toxic fumes. Make sure the area is well-ventilated when working with materials that produce harmful fumes.
6. Personal eye protection must be worn when doing any work to protect eyes from possible injury.
7. Where fasteners removed from the equipment are not satisfactory for reuse, care must be taken to select replacements that match the originals. Mismatched or incorrect fasteners can result in equipment damage or malfunction, or possible personal injury.
8. To ensure the correct functioning of each component, use only the manufacturer's genuine spare parts as replacements.
9. Follow all DANGERS, WARNINGS, CAUTIONS, and NOTES found throughout this specification. If you must use a work procedure or tool which is not recommended, you must first satisfy yourself that neither your safety, nor your fellow workers safety, nor that of the equipment will be jeopardized by the method selected.
10. Person(s) performing maintenance and/or operational tasks with the brake system and system components are required to have the appropriate job skill level, as governed by the user.





Maintenance Specification
DB20 and DB20L Doc-No: NYR-429
Emergency Portions Revision: 10 11/27/17 - en

4 TOOLS REQUIRED

Overhaul of the DB20 or DB20L Emergency Portion will be accomplished in a more efficient and safe manner through the use of the following standard and special tools.

4.1 Standard Tools

- Box end wrenches or square drive socket wrenches for hex cap screws with wrench openings of 9/16", 17/32", 3/4", 31/32", 1-5/8" and 1-13/16"
- Allen wrenches with 3/16" and 15/64" width across flats
- A flat blade screwdriver for slotted head screws with screwdriver point dimensions of 3/64" x 11/32"
- Offset snap ring pliers for internal retaining rings with 70°, 1/16" tip
- Offset pointed tweezers (7°) with overall length of approximately 5"
- A pin punch with 0.1" diameter maximum pin dimension
- A metal marking scribe with a straight end and a hooked end

4.2 Special Tools

- A flat blade screwdriver for slotted head screws with a modified screwdriver point
- Use a standard flat blade screwdriver with screwdriver point dimensions of 3/64" x 11/32" and reduce the width of the blade from 11/32" to 10/32" maximum by grinding.
- The following special tools are required. Drawings are shown in Section 11.2:
 - Special Hand Drive Pin Fig. 11-4 P/N 772617
 - Guide Pin (2 required) Fig. 11-5 P/N 772620
 - Pin-Type Fixture Fig. 11-6 and 11-7 P/N 772621
 - Retaining Ring Positioning Tool Fig. 11-8 P/N 772625
 - K-Ring Positioning Tool Fig. 11-9 P/N 772626
 - Guide Ring Assembly Tool Fig. 11-10, 11-11, and 11-12 P/N 772627
 - Thin Wall Type Mandrel Fig. 11-13 P/N 772628
 - 6mm Bore Gage Fig. 11-14 P/N 790504

❖ Special tools may be either fabricated by the user or purchased through the OEM.

Copyright 2017© NYAB. All rights reserved, including industrial property rights applications.
NYAB retains any power of disposal, such as copying and transferring.



Knorr-Bremse Group

Page 17 / 71



Maintenance Specification

DB20 and DB20L Doc-No: NYR-429
Emergency Portions Revision: 10 11/27/17 - en

5 ADHESIVES, LUBRICANTS, SEALANTS, AND SOLVENTS

The following lubricants and sealants / liquid fastening aids are used when assembling the DB20 Service Portion. Adhesives and solvents are not identified with in this document.

5.1 Lubricants

- Dow Corning 55 Silicone Grease

5.2 Sealants

- Loctite 222
- Loctite 242
- Loctite 680
- Loctite Locquic Primer T 7471
- Alodine solution (brush-on)
- Black oxide primer

Copyright 2017© NYAB. All rights reserved, including industrial property rights applications.
NYAB retains any power of disposal, such as copying and transferring.



Knorr-Bremse Group

Page 18 / 71





Maintenance Specification
DB20 and DB20L Doc-No: NYR-429
Emergency Portions Revision: 10 11/27/17 - en

6 DISASSEMBLY

6.1 Cleaning

1. All maintenance work starts with the initial external cleaning of the control valve portion with the shipping covers still in place (Refer to Fig. 10-2).

	WARNING
	<p>Solvents and solvent fumes can be harmful to health. When using solvents, be sure to:</p> <ul style="list-style-type: none">• wear eye, skin, and respiratory protection.• work in a well-ventilated area.• avoid repeated or prolonged contact.• keep solvent container closed.• keep solvent away from sparks, flames, and heat. <p>Failure to observe these safety pre-cautions can lead to injury or intoxication.</p>

	WARNING
	<p>Danger of personal injury exists. When using compressed air, be sure to:</p> <ul style="list-style-type: none">• Wear eye protection• Do not exceed 30 psig.

	CAUTION
	<p>Valve bodies should not be submerged in a solution.</p>

2. Once the valve body has been cleaned by an approved method, the shipping covers can be removed and disassembly may begin.
3. The DB20 or DB20L Emergency Portion must be completely disassembled and all parts inspected, cleaned, and lubricated at a suitable bench in a clean, well-lighted location in an A.A.R. approved air brake shop.

6.2 General Requirements

1. Use the tools specified in Section 4.

Copyright 2017© NYAB. All rights reserved, including industrial property rights applications.
NYAB retains any power of disposal, such as copying and transferring.

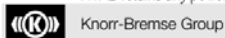



Maintenance Specification
DB20 and DB20L Doc-No: NYR-429
Emergency Portions Revision: 10 11/27/17 - en

2. It is recommended that suitable devices be made to hold the valve bodies in place during the disassembly/assembly process. In addition, it would be helpful if the valve body could be rotated horizontally by 360 degrees on this device with locking features every 90 degrees.
3. Remove and install KNORR K-Rings only in accordance with the instructions given in Fig. 6-1.
4. If necessary, use the K-Ring Positioning Tool (Fig. 11-9) and / or tweezers only, to remove and install springs, valve plates, K-Rings or O-Rings.
5. Prevent damage or abrasion to all parts of the valve, particularly machined surfaces during disassembly, cleaning and assembly.
6. The covers are used not only as sealing surfaces, but also to support various component parts. When removing/attaching covers and/or sub-components, exercise care to prevent the loss of springs, chokes, valve seats or rubber parts.
7. Some covers are recessed at the flange face. These covers cannot be knocked off laterally. If they do not loosen automatically after cap screw removal, they can be pried out by inserting a suitable flat blade screwdriver in the opposing, built-in recess.
8. The non-recessed covers should come off automatically by spring force once the cap screws have been removed. If not, they can be tapped off laterally using a soft-faced mallet.

NOTICE

NOTE

For location of choke numbers, refer to Figures 6-2 and 6-3. For location of drawing reference numbers, refer to Figures 11-1 through 11-3.

6.3 Disassembly (DB20 and DB20L Emergency Portions)

WARNING

WARNING

Compressed forces may inadvertently expel parts. Wear eye protection and exercise care during disassembly. Failure to observe these safety precautions can lead to injury.

Copyright 2017© NYAB. All rights reserved, including industrial property rights applications.
NYAB retains any power of disposal, such as copying and transferring.



Knorr-Bremse Group

Page 20 / 71



Maintenance Specification
DB20 and DB20L Doc-No: NYR-429
Emergency Portions Revision: 10 11/27/17 - en

NOTICE

NOTE

These instructions are to be performed after the DB20 or DB20L Emergency Portion is removed from the DB30 Pipe Bracket and applies to Emergency Portions that are at any configuration level. Distortion of bolts, nuts, etc. must be avoided by using tools especially adapted for this work (Refer to Section 4). Care must be taken to ensure that pistons, springs, chokes, rubber parts, etc. are protected from damage.

6.3.1 Top Cover Disassembly

(Refer to Figure 11-1)

CAUTION

CAUTION

Do not damage the sealing surfaces on cover assembly (2)

NOTICE

NOTE

To hold the valve from moving during disassembly, it may be beneficial to attach the valve to a suitable holding fixture. Adjust the valve so that "TOP COVER" surface is facing up.

1. With top cover assembly (2) facing up, remove cap screws (1). Lift off cover assembly (2). Remove and discard O-Ring (4) from cover (2). Use tweezers to remove, and then discard, filter (3).

WARNING

WARNING

Parts may be inadvertently expelled by force of spring. Wear eye protection and exercise care during disassembly. Failure to observe these safety precautions can lead to injury.

2. Loosen threaded bushing (9) with a 1-5/8" (41 mm) socket wrench. Thereafter, unscrew bushing (9) carefully by hand, so the force of the spring (5) is fully relieved before removing loose parts. Remove spring (5) and check valve (6) from bushing (9). Discard check valve (6).
3. Remove stem (10) with affixed O-Ring (11) and spring (12) (if present), from bushing (9). Discard O-Ring (11).

Copyright 2017© NYAB. All rights reserved, including industrial property rights applications. NYAB retains any power of disposal, such as copying and transferring.

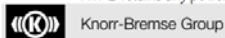



Maintenance Specification
DB20 and DB20L Doc-No: NYR-429
Emergency Portions Revision: 10 11/27/17 - en

4. Use K-Ring Positioning Tool (Fig. 11-9) to remove O-Rings (7 and 8) from bushing (9). Discard O-Rings (7 and 8).
5. Remove piston subassembly (13 through 20) from housing assembly (29).

 WARNING	WARNING Parts may be inadvertently expelled by force of spring. Wear eye protection and exercise care during disassembly. Failure to observe these safety precautions can lead to injury.
--	---

6. Use Special Hand Drive Pin (Fig. 11-4) (look for the drilled end) and push stem (19) backward to relieve the force of the spring (18) acting on the retaining ring (20). Remove retaining ring (20) with suitable pliers. Discard retaining ring (20).
7. Remove stem (19) and spring (18) from piston (17).
8. Rotate piston (17) and snap off plastic ring (13) with a screwdriver.
9. Use Pin Type Fixture (Fig. 11-6) to hold remaining piston subassembly (14-17) in place while unscrewing hex nut (14) with a 1-5/8" socket wrench.
10. Remove piston plate (15) and diaphragm (16). Discard diaphragm (16). Visually inspect piston (17) per guidelines in Section 7.2.

NOTICE	NOTE If parts of the piston subassembly remain fitted together by adhesive force after hex nut removal, for the purpose of separating them only, use a non-metallic tool and carefully strike against the piston plate.
---------------	---

11. With a 1-5/8" socket wrench, unscrew bushing (22) and remove carefully. Remove and discard two O-Rings (7) from bushing (22). Remove and discard two O-Rings (30) from housing assembly (29).

 WARNING	WARNING Parts may be inadvertently expelled by force of spring. Wear eye protection and exercise care during disassembly. Failure to observe these safety precautions can lead to injury.
--	---

Copyright 2017© NYAB. All rights reserved, including industrial property rights applications.
NYAB retains any power of disposal, such as copying and transferring.

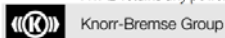



Maintenance Specification
DB20 and DB20L Doc-No: NYR-429
Emergency Portions Revision: 10 11/27/17 - en

	CAUTION Do not damage valve seat radius of bushing (27).
--	--

	NOTE Use Special Hand Drive Pin (Fig. 11-4) (look for the non-drilled end) to push out all interior parts of bushing (22).
--	--

12. Use a metal marking scriber to remove two guide rings (21). Puncture the shoulder of the guide rings (21) and move them out of their grooves; then remove with tweezers and discard guide rings (21).
13. Use K-Ring Positioning Tool (Fig. 11-9) and/or tweezers to remove check valve (23), valve guide (24), spring (25), bushing (27) with O-Ring (26), and strainer (28) from housing assembly (29). Discard check valve (23), O-Ring (26), and strainer (28).

6.3.2 Side Cover Surface Disassembly

(Refer to Figure 11-1)

1. With side cover assembly (34) facing up, remove cap screws (1). Lift off cover (34) carefully to prevent the loss of parts. Place side cover assembly (34) to one side.
2. Remove diaphragms (38 and 41). Use K-Ring Positioning Tool (Fig. 11-9) to remove spacer ring (37). Discard diaphragms (38 and 41).
3. Use K-Ring Positioning Tool (Fig. 11-9) and/or tweezers as necessary to remove spring (35), check valve (36), spring (39), spring guide (40), washer (42), spring (43), washer (44), spring (45), and strainer (46) from housing assembly (29). Discard check valve (36) and strainer (46).
4. Remove and discard two O-Rings (7) and two O-Rings (30) from housing assembly (29).

	WARNING Retaining ring (48) may be inadvertently expelled during disassembly. Wear eye protection and exercise care during removal. Failure to observe these safety precautions can lead to injury.
--	---

Copyright 2017© NYAB. All rights reserved, including industrial property rights applications.
NYAB retains any power of disposal, such as copying and transferring.

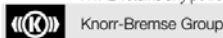



NOTICE

NOTE

Step 5 is not required on valve designs that do not contain filter (47) and locking retaining ring (48).

5. With a metal marking scriber (use the hooked end), carefully remove circular self-locking retaining ring (48). Push filter (47) with the metal marking scriber, to rotate filter (47) to approximately 90 degrees. Remove filter (47) with tweezers. Discard filter (47) and retaining ring (48).
6. Rotate housing (29) and use blade of Retaining Ring Positioning Tool (Fig. 11-8) to unscrew retaining nut w/filter (31) from back side of housing (29). Remove choke (32) and O-Ring (33) with tweezers and/or K-Ring Positioning Tool (Fig. 11-9). Discard retaining nut w/filter (31) and O-Ring (33).
7. Rotate housing (29) so vent flap (51) is facing up. Remove pop rivet (49) by drilling the head of the rivet with a 3/16" (ø 5 mm max.) drill. Remove and discard rivet (49), spacer ring (50), and vent flap (51).

CAUTION

CAUTION

Exercise care that chips do not remain in housing (29).

6.3.3 Side Cover Disassembly

(Refer to Figure 11-3)

1. Unscrew plug (13) with a suitable Allen wrench. With the now open plughole facing down, use a suitable Allen wrench to remove Choke C9.1 (12). Remove choke (12) carefully through the plughole to prevent damage to cover (1) or choke (12).
2. Valve portions with P/N I85177/001D or I85177/001L, before S/N D0-XXXXX, had a side cover (1) with pressed-in bushings. If the side cover with pressed-in bushings is damaged, replace entire cover with the new style side cover (with removable bushings and O-Rings). Discard spacer ring (37) (Figure 11-1).
3. For valve portions starting with S/N D0-XXXXX or XX-XXXXX-D0 (field repair modification suffix), remove bushings (2, 9 and 11) by blowing compressed air through the center hole of each bushing (bushing will unseat itself). Remove and discard O-Rings (3, 4 and 10) from bushings (2, 9 and 11).
4. Use blade of Retaining Ring Positioning tool (Fig. 11-8) to unscrew filter (5). Remove choke (6) and O-Ring (7) with tweezers and/or K-Ring Positioning Tool (Fig. 11-9). Rotate cover (1) to remove filter (8). Discard filter (5), O-Ring (7), and filter (8).





Maintenance Specification
DB20 and DB20L Doc-No: NYR-429
Emergency Portions Revision: 10 11/27/17 - en

6.3.4 Front Cover Surface Disassembly

(Refer to Figure 11-2)

 WARNING	WARNING Parts may be inadvertently expelled by force of spring. Wear eye protection and exercise care during disassembly. Failure to observe these safety precautions can lead to injury.
--	---

1. With front cover assembly (67) facing up, loosen cap screws (1). Remove cap screws (1), lift off cover assembly (67) and remove spring (71) from housing assembly (29).

For I85177/001D and I85177/001L pre-M0 serial numbers, as well as for 775871 and 775872 pre-N0 serial numbers, discard Inshot Piston Assembly (72). For 775871 and 775872 pre-N0 serial numbers, refer to NYS-143 for Conversion to 775871VR or 775872VR.

2. Extract piston (72) from cover (67) by lifting it by its stem. Remove K-Ring (73) (Up to S/N F0-XXXXX) and O-Ring (59) from piston (72). Remove bushing (55), two O-Rings (54), and three O-Rings (30) from housing (29). Discard K-Rings and O-Rings (30, 54, 59 and 73).
3. Unscrew and remove bushing (69) from cover (67). Use K-Ring Positioning Tool (Fig. 11-9) and/or tweezers as necessary to remove stem (70), O-Ring (11), O-Rings (26), check valve (23) and spring (68). Discard check valve (23) and O-Rings (11 and 26).

 CAUTION	CAUTION Do not damage the sealing surfaces.
--	---

 NOTICE	NOTE Housing assembly (29) contains either one bushing (64) <u>OR</u> a four-bushing (55A, 61-63) combination.
---	--

4. Rotate housing (29) so that vent flap surface is face down. Remove piston subassembly (8, 20, 52-66) by carefully pushing on lock nut (66) through the corresponding hole in the pipe bracket flange (face side) of housing (29) using a punch or a screwdriver. (See Figure 6-3 for hole proximity).
 - If piston subassembly (8, 20, 52-66) contains the four-bushing (55A, 61-63) combination, proceed to Step 5e.
 - If piston subassembly (8, 20, 52-66) contains one bushing (64), proceed to step 5f.

Copyright 2017© NYAB. All rights reserved, including industrial property rights applications.
NYAB retains any power of disposal, such as copying and transferring.

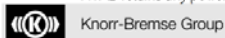





Maintenance Specification
DB20 and DB20L Doc-No: NYR-429
Emergency Portions Revision: 10 11/27/17 - en

5. For piston subassembly (8, 20, 52-66) that contains the four-bushing (55A, 61-63) combination:
 - a. Remove bushing (55A) and O-Ring (54). Discard O-Ring (54).

 WARNING	WARNING Parts may be inadvertently expelled by force of spring. Wear eye protection and exercise care during disassembly. Failure to observe these safety precautions can lead to injury.
--	---

- b. Separate piston subassembly (8, 20, 52-66) by first removing self-locking hex nut (66). To remove self-locking hex nut (66), insert a punch with 3/16" (ø 5 mm) maximum diameter, completely through the slots of bushing (63) and the hole of piston stem (57) to prevent rotating of assembly during disassembly. Remove and discard self-locking hex nut (66).
 - c. Compress piston subassembly to remove the punch and then slowly let the subassembly extend under the force of the spring (60).
 - d. Remove check valve (65) from bushing (63). Separate piston (57), spring (60), spacer ring (61) and bushing (62) from bushing (63).
 - e. Remove and discard two K-Rings (56 and 58) and O-Ring (59) from piston (57).
 - f. Remove and discard two O-Rings (8) from bushing (63).

 WARNING	WARNING Parts may be inadvertently expelled by force of spring. Wear eye protection and exercise care during disassembly. Failure to observe these safety precautions can lead to injury.
--	---

 CAUTION	CAUTION Do not damage the sealing surfaces.
--	---

- g. Use Special Hand Drive Pin (Fig. 11-4) (look for the drilled end) and push valve guide (52) backward to relieve the force of the spring (53) acting on the retaining ring (20). Remove retaining ring (20), valve guide (52), and spring (53) from piston (57). Discard retaining ring (20).

6. For piston subassembly (8, 20, 52-66) that contains one bushing (64):

Copyright 2017© NYAB. All rights reserved, including industrial property rights applications.
NYAB retains any power of disposal, such as copying and transferring.

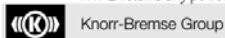



Maintenance Specification
DB20 and DB20L Doc-No: NYR-429
Emergency Portions Revision: 10 11/27/17 - en

WARNING

WARNING

Parts may be inadvertently expelled by force of spring. Wear eye protection and exercise care during disassembly. Failure to observe these safety precautions can lead to injury.

- a. Separate piston subassembly (8, 20, 52-66) by first removing self-locking hex nut (66). To remove self-locking hex nut (66) insert a punch with 3/16" (ø 5 mm) maximum diameter, completely through the slots of the bushing (64), and the hole of the piston step (57) to prevent rotating of the assembly during disassembly. Remove and discard self-locking hex nut (66).
- b. Compress piston subassembly to remove the punch and then slowly let the subassembly extend under the force of the spring (60).
- c. Remove check valve (65) from bushing (64) and piston assembly (20, 52, 53, 56- 59) from bushing (64). Discard check valve (65).
- d. Remove and discard two K-Rings (56 and 58) and O-Ring (59) from piston (57).
- e. Remove and discard two O-Rings (8) from bushing (64).

WARNING

WARNING

Parts may be inadvertently expelled by force of spring. Wear eye protection and exercise care during disassembly. Failure to observe these safety precautions can lead to injury.

CAUTION

CAUTION

Do not damage the sealing surfaces.

- f. Use Special Hand Drive Pin (Fig. 11-4) (look for the drilled end) and push valve guide (52) backward to relieve the force of spring (53) acting on the retaining ring (20). Remove retaining ring (20), valve guide (52), and spring (53) from piston (57). Discard retaining ring (20).

Copyright 2017© NYAB. All rights reserved, including industrial property rights applications.
NYAB retains any power of disposal, such as copying and transferring.



Knorr-Bremse Group

Page 27 / 71



Maintenance Specification
DB20 and DB20L Doc.-No.: NYR-429
Emergency Portions Revision: 10 11/27/17 - en



REMOVAL

Remove K-ring from groove with K-ring positioning tool and pull out completely by hand.

or:

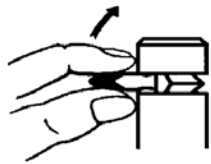

Stretch K-ring by squeezing and pushing toward one side using the thumb and forefinger. It will come out of the groove on the opposite side. Remove by hand.

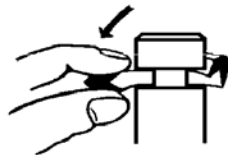

INSTALLATION

Pull slightly greased K-ring over shaft.

Expand K-ring to one side. Then manually slide it with the sealing lips ahead into the groove.

Repeat procedure until K-ring is completely inserted into the groove.

As a safety measure, move K-ring positioning tool all around between K-ring and groove wall.



CAUTION

Do not use pointed tools.
Do not damage the groove flanks.

KRING/ST1

Figure 6-1 Removal and Installation Instructions for KNORR K-Rings (outer lip seal)

Copyright 2017© NYAB. All rights reserved, including industrial property rights applications.
NYAB retains any power of disposal, such as copying and transferring.



Knorr-Bremse Group

Page 28 / 71



Maintenance Specification
 DB20 and DB20L Doc.-No.: NYR-429
 Emergency Portions Revision: 10 11/27/17 - en

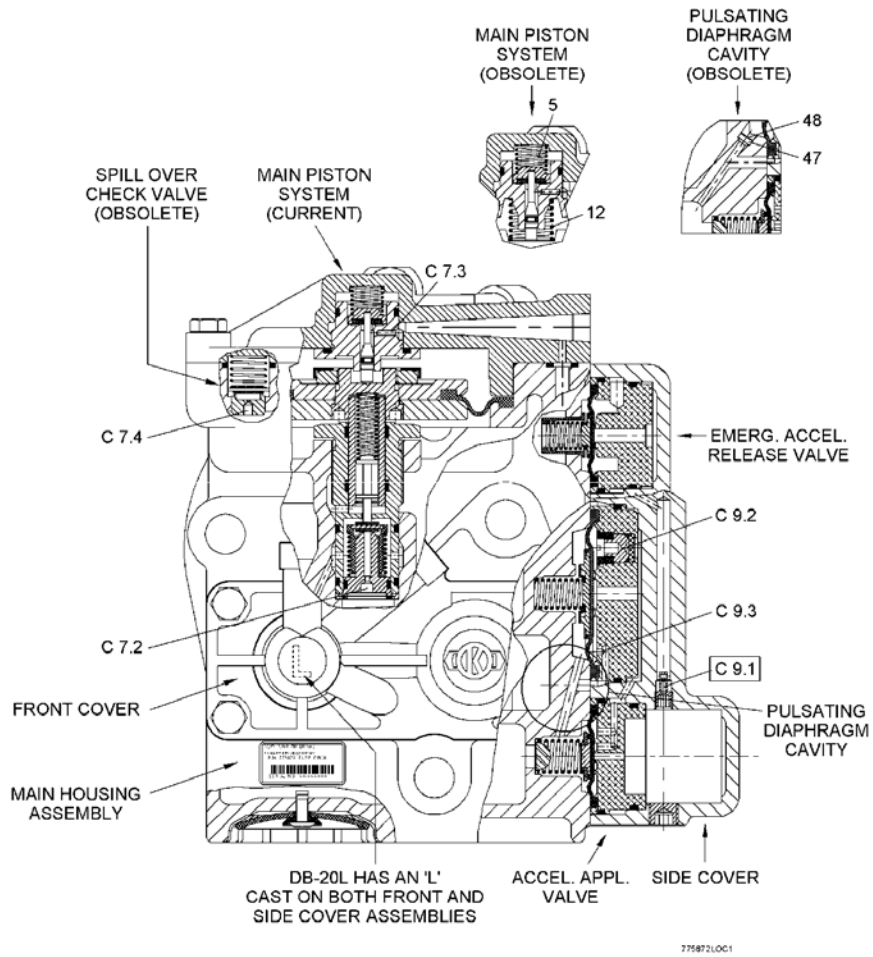
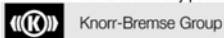

Figure 6-2 DB20 and DB20L Emergency Portion (Assembly View)

Copyright 2017© NYAB. All rights reserved, including industrial property rights applications.
 NYAB retains any power of disposal, such as copying and transferring.





Maintenance Specification
DB20 and DB20L Doc.-No.: NYR-429
Emergency Portions Revision: 10 11/27/17 - en

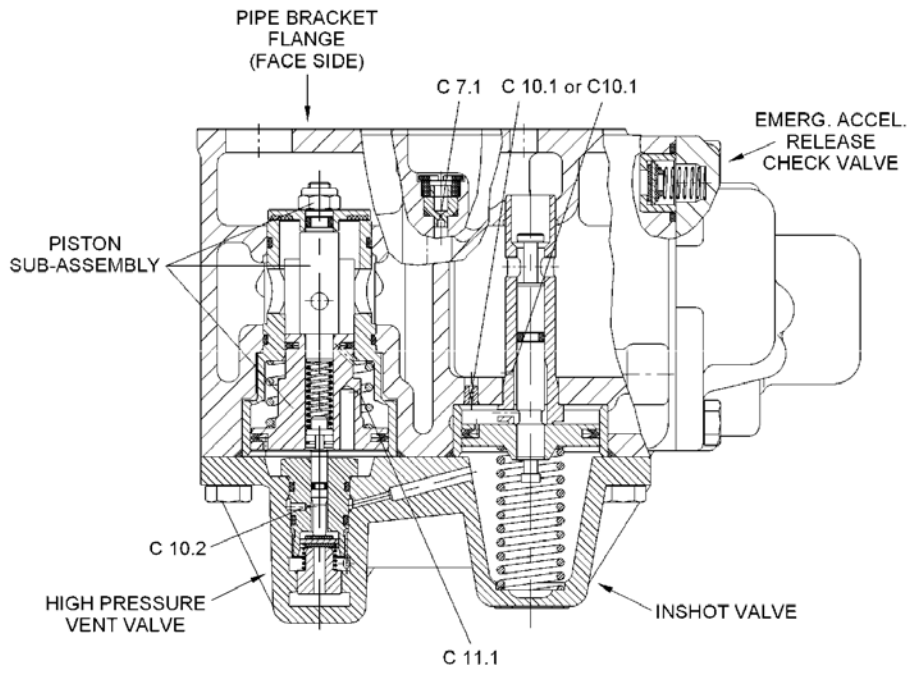

775872LOC2

Figure 6-3 DB20 and DB20L Emergency Portion (Assembly View)

Copyright 2017© NYAB. All rights reserved, including industrial property rights applications.
NYAB retains any power of disposal, such as copying and transferring.



Knorr-Bremse Group

Page 30 / 71



Maintenance Specification
DB20 and DB20L Doc-No: NYR-429
Emergency Portions Revision: 10 11/27/17 - en

7 CLEANING, INSPECTING, AND REPAIRING

7.1 Cleaning

	WARNING
	<p>Solvents and solvent fumes can be harmful to health. When using solvents, be sure to:</p> <ul style="list-style-type: none">• wear eye, skin, and respiratory protection.• work in a well-ventilated area.• avoid repeated or prolonged contact.• keep solvent container closed.• keep solvent away from sparks, flames, and heat. <p>Failure to observe these safety pre-cautions can lead to injury or intoxication.</p>

	CAUTION
	<p>Valve bodies should not be submerged in a solution.</p>

1. After complete disassembly, all parts, including the interior of the body, must be thoroughly cleaned by an approved method that will dissolve oil and grease without damage or abrasion to the parts.

	WARNING
	<p>Danger of personal injury exists. When using compressed air, be sure to:</p> <ul style="list-style-type: none">• Wear eye protection• Do not exceed 30 psig.

2. All parts, including the body, must be blown dry after cleaning.
3. Light surface corrosion on cast iron or aluminum parts must be removed by carefully cleaning with crocus cloth or emery paper. Corrosion protection that was removed and exposes bare metal must be re-applied to the affected area. For aluminum parts, apply a brush-on Alodine solution. For cast iron parts, apply a black oxide primer. Applications must be applied according to the manufacturer's specifications listed on the container.

Copyright 2017© NYAB. All rights reserved, including industrial property rights applications.
NYAB retains any power of disposal, such as copying and transferring.

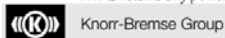



Maintenance Specification
DB20 and DB20L Doc-No: NYR-429
Emergency Portions Revision: 10 11/27/17 - en

7.2 Inspecting

1. Carefully inspect cleaned parts. If damaged (cracked, deformed or signs of rust or thread damage), replace component.
2. Visually inspect sealing, sliding and guide surfaces for scoring, scratches and excessive wear. Also examine valve seats for scoring, scratches and indentations.
3. Replace parts if scoring or scratches deeper than 0.2 mm are detected on sealing, sliding or guide surfaces, or if smaller defects cannot be fully removed during reconditioning.
4. Replace all parts that are cracked, broken, worn, damaged, or in such a condition as would result in unsatisfactory operation.
5. **MANDATORY COMPONENT MODIFICATIONS:**

NOTICE

NOTE

"Mandatory Component Modifications" MUST be made to all emergency portions that are still equipped with parts/part combinations listed in Section 7.2. If necessary, order new parts/part combinations per the parts catalog.

All of the following modifications **MUST** be done to the emergency portions. After completing these modifications, the nameplate must be stamped with the appropriate suffix after or below the existing serial number per the instructions in Section 8.

- a. **For Part Numbers I85177/001D, I85177/001L, 775871 and 775872**

NOTICE

NOTE

For I85177/001D pre-M0 configurations and 775871 pre-N0 configurations, the Inshot Piston Valve (Figure 11-2, Item 72) must be discarded and replaced with P/N 785862 in Vibration Upgrade Kit 794399.

NOTICE

NOTE

For I85177/001L pre-M0 configurations and 775872 pre-N0 configurations, the Inshot Piston Valve (Figure 11-2, Item 72) must be discarded and replaced with P/N 785862 in Vibration Upgrade Kit 794401.

Copyright 2017© NYAB. All rights reserved, including industrial property rights applications.
NYAB retains any power of disposal, such as copying and transferring.



Knorr-Bremse Group

Page 32 / 71



Maintenance Specification	
DB20 and DB20L	Doc.No.: NYR-429
Emergency Portions	Revision: 10 11/27/17 - en

E0 - Configuration

If Present: Copper Alloy Sensor Stem (10) (P/N 769313/B73405) (part deleted starting with S/N E0-XXXXX). (Refer to Figure 11-1)

Replace with: Plastic Sensor Stem (10) (P/N 777932). (Used on Emergency portions starting with S/N E0-XXXXX).

J0 – Configuration

If Present: Spring (5) (Refer to Fig. 11-1)

Replace with: New Spring (5) (Used on Emergency portions starting with S/N J0-XXXXX).

b. For Part Numbers 775871 and 775872 ONLY

G0 - Configuration

If Present: Bushing with choke (27) – has different dimensions. (Refer to Figure 11-1)

Replace with: New Bushing with choke (27).

c. For Part Numbers I85177/001D and I85177/001L ONLY

A0 - Configuration

If Present: O-Ring, Spring and Check Valve (Spillover Check Valve). (Refer to Figure 6-2 and Figure 11-1, bored hole Ref. No. 74)

Replace with: Plug (P/N 732432) and Pin (P/N 773777) (refer to the following procedure).

Procedure for Spillover Check Valve Bushing Removal and Plug Installation

- (1.) Drill out hole in spillover check valve bushing with a 1/4" drill.
- (2.) Tap hole with a 5/16 - 18 UNC tap.
- (3.) Install 5/16" x 18 UNC x 4" long screw. Turn screw in a clockwise direction until bushing is free from its seat in body.
- (4.) Remove and discard bushing. Vacuum or blow out hole.
- (5.) Apply Loctite Locquic Primer T 7471 to the new plug and to cavity of spillover check valve seat in body and the side port also.

Copyright 2017© NYAB. All rights reserved, including industrial property rights applications.
NYAB retains any power of disposal, such as copying and transferring.



Knorr-Bremse Group

Page 33 / 71



Maintenance Specification
DB20 and DB20L Doc-No: NYR-429
Emergency Portions Revision: 10 11/27/17 - en

- (6.) Place DB-20 emergency portion in a press.
- (7.) Apply Loctite 680 to the new plug (P/N 732432) and place new plug in the cavity for the check valve seat bushing.

NOTICE	NOTE Do not allow Loctite to puddle in the body; remove all excess. Failure to do this could contaminate the body when air is applied and could lead to welding of brass parts.
---------------	---

- (8.) Press the plug into the body.
- (9.) Apply Loctite 680 to the new pin (P/N 773777) and place new pin in the side port of cavity. Press the plug into the body.

B0 - Configuration

If Present: Springs (12) and (5) (both parts deleted starting with S/N B0-XXXXX). (Refer to Figure 11-1)

Replace with: New Spring (5) (colored green). (Used on Emergency portions starting with S/N B0-XXXXX).

C0 - Configuration

If Present: Remove and discard retaining ring (48) and filter (47) (both parts deleted starting with S/N C0-XXXXX). (Refer to Figure 11-1)

DO NOT REPLACE.

6. NON-MANDATORY COMPONENT MODIFICATIONS:

NOTICE	NOTE "Non-Mandatory Component Modifications" can be made to all emergency portions, depending on the damage or wear condition of the parts/part combinations listed in Section 7.2. If necessary, order new parts/part combinations per the parts catalog. If damage or excessive wear is present on the part/parts listed in the "If Damaged" category, perform the component modification(s) in the "Replace with" category.
---------------	--

Copyright 2017© NYAB. All rights reserved, including industrial property rights applications. NYAB retains any power of disposal, such as copying and transferring.

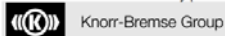



a. **For Part Numbers 775871 and 775872 ONLY**

K0 – Configuration

Composite parts used on service portions with S/N K0-XXXXX do not need to be replaced. They are now used on service portions starting with S/N N0-XXXXX.

b. **For Part Numbers I85177/001D and I85177/001L ONLY**

If Damaged: Threaded bushing (22), (without grooves inside for guide rings). (Refer to Figure 11-1)

Replace with: Threaded bushing (22), (with two grooves inside for guide rings) and guide rings (21) (two required).

C0 - Configuration

If Damaged: Bushing (55A), spacer ring (61), vent valve bushing (62), and bushing with valve seat (63). If any of these components is damaged or has excessive wear, all must be replaced with bushing (64) (Refer to Figure 11-2)

Replace with: Bushing (64), (used on portions starting with S/N C0-34000).

D0 – Configuration

If Damaged: Spacer ring (37) and side cover (34) (used on portions before S/N D0-XXXXX). (Refer to Figure 11-1)

Replace with: Spacer ring (37) is deleted. Its function is designed into new cover (34) (used on portions starting with S/N D0-XXXXX). New cover (34) must be used when deleting spacer ring (37).





Maintenance Specification
DB20 and DB20L Doc.-No.: NYR-429
Emergency Portions Revision: 10 11/27/17 - en

7. **GAUGING:**

Valve Seat (9) (Fig. 11-1) (page 57) – Maximum measurement of inside diameter is 6.027 mm. If greater than 6.027 mm, then component must be replaced. Use 6mm Bore Gage (Fig. 11-14) to measure dimension.

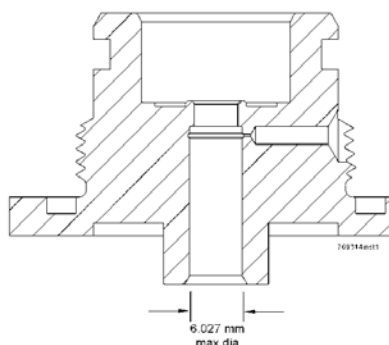

Figure 7-1 Valve Seat (Item # 9 in Figure 11-1)

7.3 **Springs**

NOTICE

NOTE

* New spring (5) (colored green) replaces springs (5 and 12) (Figure 11-1). See Figure 6-2 for "obsolete" and "current" spring locations.

◆ Both design springs (39) are valid and interchangeable. The new design spring (39) snap-fits onto diaphragm (38) to aid in assembly.

1. DB-20 and DB-20L Emergency Portions with P/N I85177/001D and I85177/001L, without the numeral '1' cast on the body (see Fig. 2-4, Page 14) contain a spill over check valve spring (Fig. 6-2) and have a total of 13 springs.
2. DB20 and DB-20L Emergency Portions with P/N I85177/001D and I85177/001L, S/N A0-XXXXX and have the numeral '1' cast on the body (see Fig. 2-4, Page 14) do not contain a spill over check valve spring (Fig. 6-2) and have a total of 12 springs.
3. DB-20 and DB-20L Emergency Portions with P/N I85177/001D and I85177/001L, S/N B0-XXXXX and have the numeral '1' cast on the body (see Fig. 2-4, Page 14), do not contain a spill over check valve spring (Fig. 6-2) or a compensating spring (12) (Fig. 11-1) and have a total of 11 springs.

Copyright 2017© NYAB. All rights reserved, including industrial property rights applications. NYAB retains any power of disposal, such as copying and transferring.

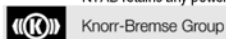



Maintenance Specification
DB20 and DB20L Doc-No: NYR-429
Emergency Portions Revision: 10 11/27/17 - en

NOTICE

NOTE

Emergency Portions without numeral '1' on the housing (see Fig. 2-4, Page 14) also contain a spill over check valve spring (Figure 6-2). Remove and discard spring, check valve, and O-Ring (see section 7.2 for mandatory modification instructions).

7.4 Chokes

1. The size of the chokes in the valve portion is important for proper valve performance. Whenever a portion is disassembled, all chokes must be inspected and cleaned to ensure they are not restricted. When cleaning chokes, the orifice size and shape must not be changed.
2. For proper choke size identification see Table 7-3.
3. Threaded chokes generally can be removed or applied without damage to choke plug or to the thread in the tapped hole. If necessary to drill or tap, all drill chips must be thoroughly blown out of passages.
4. Passages must be checked for cleanliness and blown out if necessary, after chokes are removed. Chokes must then be returned to their proper location.
5. Actual choke diameters must meet the limits specified in Table 7-3 for the DB-20 and DB-20L Emergency Portion.
6. There are 9 chokes used throughout the DB-20 and DB-20L Emergency Portion. All chokes are required once.

NOTICE

NOTE

Valve portions without the numeral '1' cast on the body (see Fig. 2-4, Page 14) contain a spill over check valve choke (C7.4) (Fig. 6-2) which is deleted upon overhaul (see Section 7.2 for modification instructions).

7. DB20 and DB20L Portions both contain eight of the same chokes. The BP-Pressure Discharging choke 9.1 (Fig. 6-2), also shown as choke (12) (Fig. 11-3), is a different size in the DB20 than in the DB20L.
8. Choke disassembly/assembly can only be done as a special operation. Order complete sub-assembly per parts catalog for replacement of the choke. For replacement of chokes contained in individual parts, order respective parts per parts catalog.

Copyright 2017© NYAB. All rights reserved, including industrial property rights applications.
NYAB retains any power of disposal, such as copying and transferring.



Knorr-Bremse Group

Page 37 / 71



Maintenance Specification
 DB20 and DB20L Doc-No: NYR-429
 Emergency Portions Revision: 10 11/27/17 - en

Table 7-1 Choke Identification

Fig. No.	Choke No.	Ref. No.	Description	Dia. min. / max. mm (inches)
11-1	C 7.3	9	Sensor Valve Choke	0.280/0.320 (0.0110/0.0126)
11-1	C 7.2	27	Emergency Sensitivity Choke	2.034/2.059 (0.0801/0.0811)
11-1	C7.1	32	QA – Chamber Charging Choke	0.500/0.530 (0.0197/0.0209)
*	C 9.3	*	Accelerated Application Choke	2.500/2.560 (0.0984/0.1008)
◆	C 10.1	◆	Inshot Valve Volume Choke	0.900/0.960 (0.0354/0.0378)
11-2	C10.2	69	Inshot Valve Control Choke	0.500/0.530 (0.0197/0.0209)
*	C 11.1	*	QA-Pressure Blow Down Choke	0.550/0.600 (0.0217/0.0236)
11-3	C 9.2	6	Accelerated Application Sensitivity Choke	0.200/0.230 (0.0256/0.0268)
11-3	C 9.1 (DB-20)	13	BP-Pressure Discharging Choke	0.650/0.680 (0.0256/0.0268)
11-3	C 9.1 (DB-20L)	13	BP-Pressure Discharging Choke	0.850/0.890 (0.0335/0.0350)

	<p>NOTE</p> <p>*These chokes are part of a subassembly (refer to Figures 6-2 and 6-3).</p> <p>◆This choke (C 10.1) is located in housing assembly (29). It is either adjacent to the bushing or it is integrated into the bushing that inshot valve piston assembly (72) stem fits into. (Refer to Figure 11-2)</p>
--	--

7.5 Rubber Parts

1. All rubber parts must be replaced with new parts when reassembling the valve. All items can be identified for ordering purposes per the parts catalog.
2. New rubber parts that have been in storage for more than five years must not be used.
3. The storage area for rubber parts must be cool, dark, and free from dampness and mildew. Since most rubber goods are affected by ozone, they must not be stored near electrical equipment that may generate ozone.
4. To determine shelf life, new rubber repair kits must be dated with the oldest date (half-year) of rubber components contained within the repair kit.

Copyright 2017© NYAB. All rights reserved, including industrial property rights applications. NYAB retains any power of disposal, such as copying and transferring.



Maintenance Specification
DB20 and DB20L Doc.No.: NYR-429
Emergency Portions Revision: 10 11/27/17 - en

7.6 Filters and Accessory Parts

All filters and accessory parts have to be replaced by new parts when reassembling the valves. All items are part of a separate Repair Kit, which has to be ordered per the parts catalog.

NOTICE

NOTE

DB20 and DB20L Emergency Portions with P/N I85177/001D and I85177/001L, and starting with S/N C0-XXXXX or XX-XXXXX-C0 do not contain filter (47) and retaining ring (48) (Figure 11-1). When rebuilding Emergency valve portions with a serial number prefix of "A0" or "B0", remove filter (47) and circular retaining ring (48) and do not reinstall.





Maintenance Specification
DB20 and DB20L Doc.No.: NYR-429
Emergency Portions Revision: 10 11/27/17 - en

8 LUBRICATING AND REASSEMBLY

8.1 Lubrication

1. All sliding surfaces and all parts with their respective grooves should be coated with a light film of Dow Corning 55 Silicone Grease. Remove excess grease by wiping.

NOTICE

NOTE

Coat O-Rings and K-Rings with only a light film of grease. Do not apply grease to check valves and diaphragms. Wipe face of new check valves to ensure a contaminant-free surface.

2. During re-assembly of valve portions, only use the Thin Wall Type Mandrel (Fig.11-13) in order to prevent damage to specific O-Rings.
3. The supply of O-Rings kept on a mandrel must not exceed daily requirements to prevent permanent stretch. In addition, caution must be used to protect against contamination from dirt and foreign matter damaging O-Rings and lubricant.

NOTICE

NOTE

To prevent restriction of small orifices, do not apply grease to the threads of the main piston assembly.

Copyright 2017© NYAB. All rights reserved, including industrial property rights applications.
NYAB retains any power of disposal, such as copying and transferring.



Knorr-Bremse Group

Page 40 / 71



Maintenance Specification
 DB20 and DB20L Doc.No.: NYR-429
 Emergency Portions Revision: 10 11/27/17 - en

8.2 Torque Requirements – DB-20 and DB-20L Emerg. Portions

When reassembling DB20 or DB20L Emergency Portion, cap screws and nuts must be tightened sufficiently to prevent gasket leakage, and yet not so tight as to cause distortion of covers and gaskets.

Recommended torque values for cap screws, nuts and threaded bushings are listed in the following tabulation:

Table 8-1 Torque Requirements

FIG. No.	PART NAME & ITEM No.	TORQUE LIMITS IN FOOT POUNDS (Nm)
11-1	Cover cap screw – (1)	20 to 24 (28 to 32)
11-1	Threaded bushing – (9 and 22)	10 to 15 (14 to 20)
11-1	Hex nut (Refer to Note) – (14)	35 to 39 (48 to 52)
11-2	Cover cap screw – (1)	20 to 24 (28 to 32)
11-2	Threaded bushing – (69)	10 to 15 (14 to 20)
11-2	Hex nut – (66)	5 to 7 (7 to 10)
11-2	Choke 9.1 (Refer to Note) – (12)	20 to 30 in-lbs (3 to 4)

NOTICE

NOTE

Prior to installing hex nut (14) (Fig. 11-1), apply Loctite 242 to inside threads [see also assembly procedure of the main piston sub-assembly (14-17), in Section 8.3.3].

Prior to installing Choke 9.1 (12) (Fig. 11-3) into side cover (1), apply a thin layer of Loctite 222 to outside threads (see also assembly procedure of side cover in Section 8.3.4).

Copyright 2017© NYAB. All rights reserved, including industrial property rights applications.
 NYAB retains any power of disposal, such as copying and transferring.



Knorr-Bremse Group

Page 41 / 71



Maintenance Specification
DB20 and DB20L Doc-No: NYR-429
Emergency Portions Revision: 10 11/27/17 - en

8.3 Assembly of DB20 and DB20L Emergency Portions

NOTICE

NOTE

Use only NYAB parts as identified in the Parts Catalog.

8.3.1 DB20 and DB20L Requirements for Assembly

1. Prior to assembly, make sure that all conditions as prescribed in Section 7 have been completed.
2. Whenever possible, avoid using dissimilar metal covers or subassemblies.
3. Aluminum bodies **must** receive aluminum covers and subassemblies.
4. Aluminum covers or subassemblies may be used with cast iron bodies if cast iron covers or subassemblies are not available.
5. During assembly, all parts **MUST** fit together easily. Do not "force-fit" parts, as damage to the valve or malfunction may result.
6. Install Knorr K-Rings only in accordance with the instructions given in Fig. 6-1, Page 28.
7. When inserting K-Ring equipped pistons into their piston cavities, make sure the K-Rings are properly centered on the pistons so as to preclude damage to the sealing surfaces during installation.
8. When placing the covers on the housings of the valve portion, be sure all rubber diaphragms and O-Rings are seated properly in their respective grooves so they are not pinched or damaged when the covers are applied.

CAUTION

CAUTION

Improper or incorrect installation of springs will result in valve malfunction.

9. Assure that all springs are seated properly, and the correct springs are being installed within the appropriate location.
10. Ensure that all threaded parts are hand tightened before applying a torque with a wrench to preclude cross threading. **For proper torque requirements see Section 8.2 (Table 8-1).**

NOTICE

NOTE

Choke orifices must remain free of obstructions.

Copyright 2017© NYAB. All rights reserved, including industrial property rights applications.
NYAB retains any power of disposal, such as copying and transferring.



Knorr-Bremse Group

Page 42 / 71



Maintenance Specification
DB20 and DB20L Doc-No: NYR-429
Emergency Portions Revision: 10 11/27/17 - en

8.3.2 Assembly of DB20 and DB20L Front Cover Surface

(Refer to Figure 11-2)

NOTICE

NOTE

To hold the valve from moving during assembly, it may be beneficial to attach the valve to a suitable holding fixture.

For proper installation of all parts, refer to Figures 6-2 and 6-3, and Figures 11-1 to 11-3 in Section 11.

NOTICE

NOTE

Position valve so that 'Front' cover (67) surface is facing up.

Before inserting all items, make sure that choke 10.1 is free of obstructions. Choke 10.1 may be located either adjacent to the bushing, or is in the bushing, that Inshot valve piston assembly (72) stem fits into. (Refer to Fig. 6-3)

1. Use thin wall type mandrel (Fig. 11-13) to insert new O-Ring (59) onto piston (57). Use K-Ring Positioning Tool (Fig. 11-9) to insert new K-Rings (56 & 58) onto piston (57).
2. Place spring (53) and valve guide (52) into piston (57). Use Special Hand Drive Pin (Fig. 11-4) (look for the drilled end) and push valve guide (52) backward so that new retaining ring (20) can be installed into piston (57).
3. If items 55A and 61 – 63 have been replaced by item 64 proceed to step 4; if not, proceed to step 7.
4. Insert spring (60) into bushing (64). Align and compress piston subassembly (20, 52, 53, 56-59) against the force of the spring (60).

WARNING

WARNING

Parts may be inadvertently expelled by force of spring. Wear eye protection and exercise care during disassembly. Failure to observe these safety precautions can lead to injury.

Copyright 2017© NYAB. All rights reserved, including industrial property rights applications.
NYAB retains any power of disposal, such as copying and transferring.



Knorr-Bremse Group

Page 43 / 71



NEW YORK AIR BRAKE

Maintenance Specification

DE20 and DE20L Doc-No: NYR-429
Emergency Portions Revision: 10 11/27/17 - en

5. Insert a punch with 3/16" dia. max. (\varnothing 5 mm max.) completely through the slots of bushing (64) and the hole of piston stem (57). Let the subassembly extend. Assemble new check valve (65) and new self-locking hex nut (66) to piston assembly stem (57). Torque nut (66) to 5-7 ft-lbs. (7-10 Nm) with a 17/32" socket wrench (torque wrench) while holding the piston subassembly with the punch to prevent rotation. Install two new O-rings (8) onto bushing (64).
6. With Front Cover (67) surface facing up, place entire piston assembly (8, 20, 52, 53, and 56 thru 66) into housing assembly (29). Proceed to step 10.
7. Install new O-Ring (8) onto bushing (62), and then assemble spacer ring (61), bushing (62) and bushing (63) together. Insert spring (60) into bushings (61-63). Align and compress the piston subassembly (20, 52, 53, 56-59) against the force of the spring (60).



WARNING

WARNING

Parts may be inadvertently expelled by force of spring. Wear eye protection and exercise care during disassembly. Failure to observe these safety precautions can lead to injury.

8. Insert a punch with 3/16" dia. max. (\varnothing 5 mm max.) completely through the slots of bushing (63) and the hole of piston stem (57). Let the subassembly extend. Assemble new check valve (65) and new self-locking hex nut (66) to piston assembly stem (57). Torque nut (66) to 5-7 ft-lbs. (7-10 Nm) with a 17/32" socket wrench (torque wrench) while holding the piston subassembly with the punch to prevent rotation. Install new O-Ring (8) onto bushing (63).
9. With Front Cover (67) surface facing up, place entire piston assembly (8, 20, 52, 53, and 56 thru 66) into housing assembly (29). Install bushing 55A over piston (57). Proceed to step 10.

NOTICE

NOTE

Piston Assembly (72) is part of Conversion covered in NYS-143 to include Vibration Upgrade.

10. Install new O-Rings (59) and (73) onto piston assembly (72). Insert piston assembly (72), spring (71), and bushing (55) into housing (29).
11. Place two new O-Rings (26) onto bushing (69) and one new O-Ring (11) onto stem (70). Place stem (70) into bushing (69).
12. Insert spring (68) and new check valve (23) into cover (67). Hand-tighten bushing (69) into cover (67). Torque bushing (69) to 10-15 ft-lbs. (14-20 Nm).

Copyright 2017© NYAB. All rights reserved, including industrial property rights applications.
NYAB retains any power of disposal, such as copying and transferring.



Knorr-Bremse Group

Page 44 / 71



Maintenance Specification	
DB20 and DB20L	Doc-No: NYR-429
Emergency Portions	Revision: 10 11/27/17 - en

13. Place two new O-Rings (54) and three new O-Rings (30) into housing (29). Secure cover (67) onto housing (29) using hex head cap screws (1). Tighten cap screws (1) to 20-24 ft-lbs. (28-32 Nm).

8.3.3 Assembly of DB20 and DB20L Top Cover Surface

(Refer to Figure 11-1)

NOTICE

NOTE

Attach valve to a suitable fixture so that 'Top' cover (2) surface is facing up.

1. Assemble main piston (17) subassembly by first placing piston (17) into Pin Type Fixture (Fig. 11-6 and 11-7) to hold in place during further assembly.

NOTICE

NOTE

Apply a thin layer of Loctite 242 to threads of special hex nut (14) and piston (17) prior to assembly.

2. Place new diaphragm (16), and piston plate (15) onto piston (17). Screw nut (14) onto piston (17). Tighten nut (14) to 35-39 ft-lbs. (48-52 Nm) with a 1-5/8" socket wrench (torque wrench). Push ring (13) firmly in place over nut (14).
3. Insert spring (18) and stem (19) into piston (17) and secure in place using new retaining ring (20).
4. If threaded bushing (22) without grooves inside, has been replaced by threaded bushing (22) with grooves, proceed to step 3. If not, proceed to step 4.
5. For threaded bushing (22) with grooves inside. Insert two new guide rings (21) into bushing (22) as follows:
6. Take a guide strap, form it to a circle and load Guide Ring Assembly Tool (Fig. 11-10, 11-11, and 11-12).
7. Insert the loaded Assembly Tool as far as possible into bushing (22), and then push the pin of the tool to unload the formed guide strap.
8. Remove the Assembly Tool and use tweezers to place one guide ring fully into its groove in bushing (22).
9. With the pin end in front, insert the Guide Ring Assembly Tool (Fig. 11-10, 11-11, and 11-12) again into bushing (22) as far as possible.

Copyright 2017© NYAB. All rights reserved, including industrial property rights applications.
NYAB retains any power of disposal, such as copying and transferring.



Knorr-Bremse Group

Page 45 / 71



Maintenance Specification
DB20 and DB20L Doc-No: NYR-429
Emergency Portions Revision: 10 11/27/17 - en

10. Turn the Assembly Tool forward and back to place the new guide ring (21) complete to its proper position.
11. Repeat the foregoing procedure to assemble the second guide ring (21).

NOTICE

NOTE

It is unnecessary to lubricate O-Ring (26). Bushing (27) must be replaced by new bushing (27) for P/N 775871 and P/N 775872 with a serial number of "G0-XXXXX".

12. Install two new O-Rings (7) onto bushing (22). Place new, dry O-Ring (26) onto bushing (27). Insert new check valve (23), valve guide (24), spring (25), and bushing (27) into threaded bushing (22).

WARNING

WARNING

Parts may be inadvertently expelled by force of spring. Wear eye protection and exercise care during disassembly. Failure to observe these safety precautions can lead to injury.

NOTICE

NOTE

Be careful not to damage the valve seat radius of bushing (27).

13. Place new strainer (28) into its groove in bushing (22) and then screw bushing sub-assembly (7, 21-28) carefully into housing (29).

NOTICE

NOTE

If the fitted sub-component (26-28) does not remain together in bushing (22) (ex: expelled by spring force), place each part (28, 27 with 26, 25, 24, and 23) individually into housing (29) with tweezers. Then screw bushing (22) carefully into housing (29).

Torque bushing (22) with a 1-5/8" socket wrench (torque wrench) to 10-15 ft-lbs. (14-20 Nm).

Copyright 2017© NYAB. All rights reserved, including industrial property rights applications.
NYAB retains any power of disposal, such as copying and transferring.



Knorr-Bremse Group

Page 46 / 71



14. Place piston sub-assembly (13-20) into housing (29). Place new O-Ring (11) onto stem (10). Place new O-Rings (7 & 8) onto bushing (9) and place stem (10) into bushing (9). Insert spring (5) and new check valve (6) into top cover (2). Hand-tighten bushing (9) into cover (2). Torque bushing (9) to 10-15 ft-lbs. (14-20 Nm).
15. Insert new filter (3) into cover (2) and place new O-Ring (4) onto cover (2). Insert two new O-Rings (30) and one new O-Ring (7) into housing (29). Make sure that the diaphragm (16) is seated properly in its groove and install top cover (2) to housing (29) using cap screws (1). Torque cap screws (1) to 20-24 ft-lbs. (28-32 Nm).

8.3.4 Assembly of DB20 and DB20L Side Cover Surface

(Refer to Figure 11-3)

NOTICE

NOTE

Make sure the hole in choke (12) and the hole in cover (1) are free of obstructions before replacing choke (12) and plug (13).

1. Apply a thin layer of Loctite 222 to threads of choke (12). With the plughole in cover (1) facing downward, screw choke (12) carefully into cover (1). Torque choke (12) to 20-30 in-lbs. (3-4 Nm).
2. Screw plug (13) into cover (1).
3. If side cover (1) has been replaced with bushings (2, 9, and 11) that have O-Rings, proceed to step 6. If not proceed to step 7.
4. For cover (1) with O-Rings on bushings (2, 9, and 11). Place new O-Rings (3 & 4) onto bushings (2 and 11) and new O-Ring (10) onto bushing (9). Insert bushings (2, 9, and 11) into cover (1).
5. Insert new filter (8), new O-Ring (7), and choke (6) into cover (1). Secure in place by screwing new retaining nut (5) firmly into cover (1).
6. For cover (1) without O-Rings on bushings (2, 9, and 11). Insert new filter (8), new O-Ring (7), and choke (6) into cover (1). Secure in place by screwing new retaining nut (5) firmly into cover (1). Proceed to step 7.

(Refer to Figure 11-1)

NOTICE

NOTE

Attach valve to a suitable fixture so that 'Side' cover (34) surface is facing up.





Maintenance Specification
DB20 and DB20L Doc-No: NYR-429
Emergency Portions Revision: 10 11/27/17 - en

7. Insert two new O-Rings (7) and two new O-Rings (30) into housing assembly (29). Insert new check valve (36) and spring (35) into housing (29).
8. Insert spring guide (40), spring (39), and new diaphragm (38) into housing (29).

NOTICE

NOTE

If unit is being overhauled using old style side cover (34) (used on portions before S/N-D0-XXXXX), spacer ring (37) must be installed. If new style side cover (34) (with O-Rings) is being used, DO NOT install spacer ring (37).

9. Insert spring (43), washer (42), and new diaphragm (41) into housing (29).
10. Insert new strainer (46), spring (45), washer (44), and new diaphragm (38) into housing (29).

NOTICE

NOTE

Diaphragms (38 & 41) must be seated properly in their grooves in cover subassembly (34) to prevent damage or malfunction of the parts. Proper assembly of the diaphragm and careful handling allows rotation of the cover without the loss of parts while diaphragms are facing downwards.

11. Insert two guide pins (Fig. 15) diagonally into two threaded holes in housing (29). Use those pins as guides to attach cover subassembly (34) to housing (29). Make sure that the diaphragms (38 & 41) are seated properly in their grooves and install side cover (34) to housing (29) using cap screws (1). Torque cap screws (1) to 20-24 ft-lbs. (28-32 Nm).
12. Rotate housing (29) and insert new O-Ring (33) and choke (32) into back side of housing (29). Secure in place by screwing new retaining nut w/filter (31) firmly into housing (29).
13. Rotate housing (29) and fasten new vent flap (51) and new spacer ring (50) to housing (29) using a new pop rivet (49) [3/16" dia. (ø 5 mm max.) and 11/16" (ø 18 mm max.) in length].

NOTICE

NOTE

Do not use a pop rivet with a head size larger than 15/32" dia. (ø 11.8 mm max.).

Copyright 2017© NYAB. All rights reserved, including industrial property rights applications.
NYAB retains any power of disposal, such as copying and transferring.

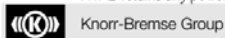



Maintenance Specification	
DB20 and DB20L	Doc-No: NYR-429
Emergency Portions	Revision: 10 11/27/17 - en

8.3.5 Nameplate Identification for DB20 and DB20L

1. After performing all of the mandatory modifications listed in Section 7.2 and assembly is completed, look on the nameplate of the DB20 Emergency Portion. If the data stamped on it is illegible or the nameplate is damaged or missing, the nameplate must be replaced.
2. Replacement nameplates are available by contacting NYAB or a NYAB representative. Replacement nameplates will have an assigned serial number with the current **mandatory** modification as a suffix.
3. If the DB20 Emergency Portion has been upgraded by performing any of the modifications from Section 7.2, it must be stamped with the applicable suffix after, or below, the existing serial number to identify that the **mandatory** valve modifications have been performed.
4. As an alternative method to steps 2 and 3 above, a COT&S tag may be attached to DB20 in place of the nameplate:
 - Warranty information will consist of a bolt-on tag and adhesive label.
 - Adhesive label shall include: repair location, part number, test date and warranty expiration date.
 - Serial prefix (engineering revision) shall be a two letter indicator stamped into the bolt-on tag or a two letter indicator printed on the adhesive tag.
 - No serialization is required
5. Since most repair facilities completely strip all internal components from the body and these do not stay linked to the body that they came out of, the non-mandatory modifications may or may not remain in a portion that was originally manufactured with them. By design, a portion is backward and forward compatible with respect to the non-mandatory modifications. Mandatory modifications are not backward compatible. It is necessary to know a portions status of mandatory modifications in order to ensure that the required repairs are correctly identified and performed. Therefore, the repaired portion shall be stamped with the most current **mandatory** modification.
 - a. For P/N I85177/001D and I85177/001L

Any mandatory modifications that occurred after the repaired portion's manufacture date must be performed on the repaired portion before it can have the configuration letter representing the latest mandatory modification as its suffix on the nameplate. For example, an older manufactured portion after repair might be stamped 'B0-XXXXX-L0'. Always consult with NYAB for the current mandatory modifications.
 - b. For P/N 775871 and 775872

Any mandatory modifications that occurred after the repaired portion's manufacture date must be performed on the repaired portion before it can have the configuration letter representing the latest mandatory modification as its suffix on the nameplate. For example, an older manufactured portion after repair

Copyright 2017© NYAB. All rights reserved, including industrial property rights applications.
NYAB retains any power of disposal, such as copying and transferring.



Knorr-Bremse Group

Page 49 / 71



Maintenance Specification	
DB20 and DB20L	Doc-No: NYR-429
Emergency Portions	Revision: 10 11/27/17 - en

might be stamped 'E0-XXXXX-P0'. Always consult with NYAB for the current mandatory modifications.

9 TESTING

1. Cleaned and repaired Emergency Portions must pass prescribed tests on the A.A.R. standard test rack in accordance with Test Instructions NYT-1200-C or on the ATR-1100 Test Rack in accordance with Test Instructions NYT-1698-S.
2. After the DB20 or DB20L Emergency Portion has passed this Code of Tests and has been removed from the test rack, it must be stenciled (see below) and a shipping cover (see Section 10.0) must be applied. The shipping cover must not be removed until the portion is ready to be installed on a car.
3. Control valve portions that have successfully passed testing must be identified and marked.
4. A suitable surface of each portion must be stenciled with letters at least ½" high in accordance with Fig. 10-1, page 51.

10 MATERIAL HANDLING

1. When the emergency portion is not attached to the pipe bracket, a special shipping cover must be fitted to the emergency portion for protection against dirt and damage (see Figures 10-2 and 10-3).
2. These covers and guards must be applied to the emergency portions as soon as they have passed the Code of Tests on the test rack and must not be removed until the cleaned valve portions are ready to be applied to the car. Even then, special precautions must be taken to avoid damaging the parts or getting dirt into the operating portions when applying them.
3. The shipping cover, shown in Fig. 10-3, can be used for all currently A.A.R. approved emergency valve portions.

Copyright 2017© NYAB. All rights reserved, including industrial property rights applications.
NYAB retains any power of disposal, such as copying and transferring.



Knorr-Bremse Group

Page 50 / 71



Maintenance Specification
 DB20 and DB20L Doc.-No.: NYR-429
 Emergency Portions Revision: 10 11/27/17 - en

Example 1

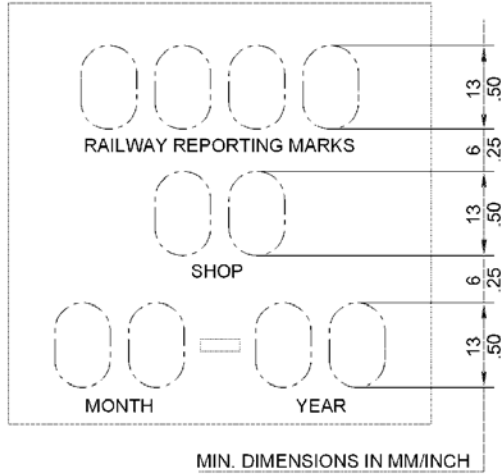

Example 2

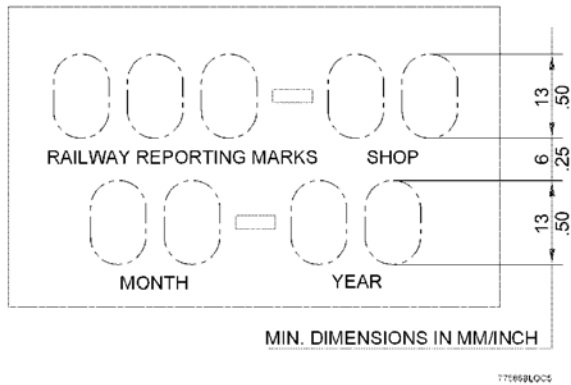
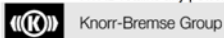

Figure 10-1 Examples of Valve Portion Stenciling with Required Information

Copyright 2017© NYAB. All rights reserved, including industrial property rights applications.
 NYAB retains any power of disposal, such as copying and transferring.





Maintenance Specification
DB20 and DB20L Doc.-No.: NYR-429
Emergency Portions Revision: 10 11/27/17 - en

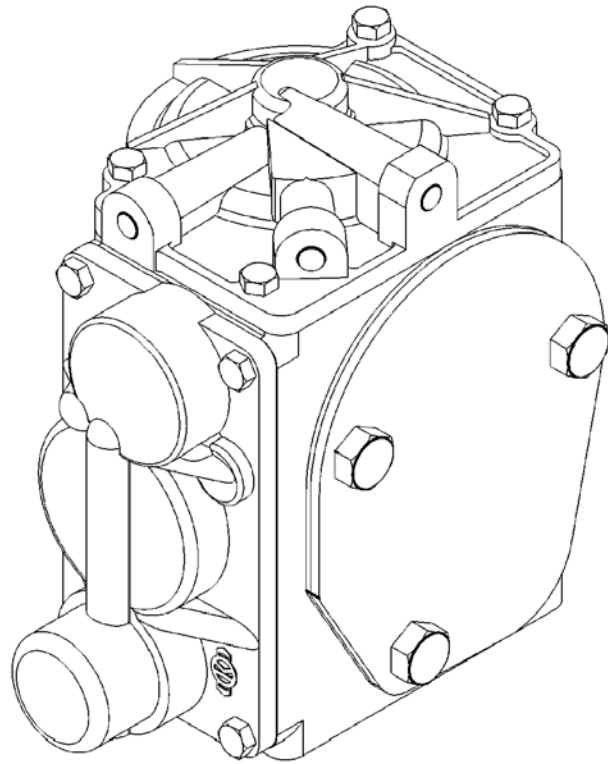

DB-20
Emergency Portion
771C48ASSY1

Figure 10-2 DB20 Emergency Portion with Shipping Cover Installed

Copyright 2017© NYAB. All rights reserved, including industrial property rights applications.
NYAB retains any power of disposal, such as copying and transferring.



Knorr-Bremse Group

Page 52 / 71



Maintenance Specification	
DB20 and DB20L	Doc-No: NYR-429
Emergency Portions	Revision: 10 11/27/17 - en

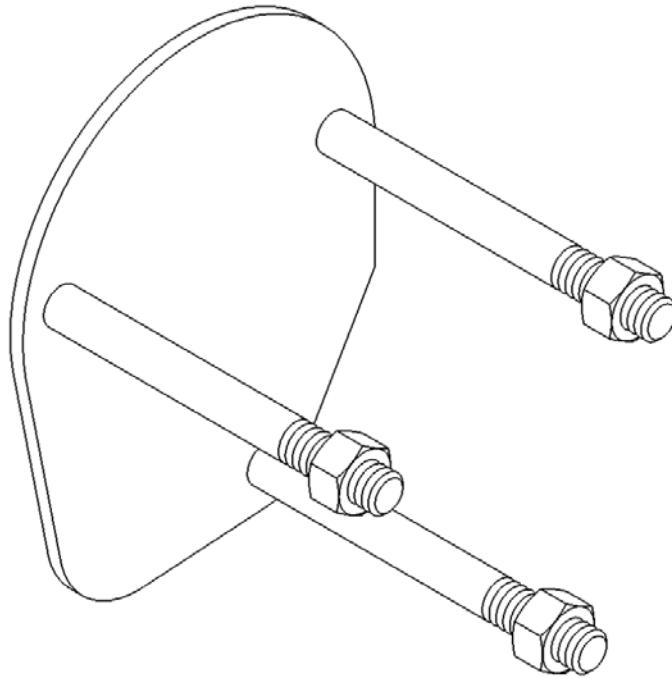

Emergency Portion

755670ASSY1

Figure 10-3 DB20 Emergency Portion Shipping Cover

Copyright 2017© NYAB. All rights reserved, including industrial property rights applications.
NYAB retains any power of disposal, such as copying and transferring.



Knorr-Bremse Group

Page 53 / 71



Maintenance Specification
DB20 and DB20L Doc.-No.: NYR-429
Emergency Portions Revision: 10 11/27/17 - en

11 SUPPORT INFORMATION

11.1 DB20 and DB20L Emergency Portion Parts

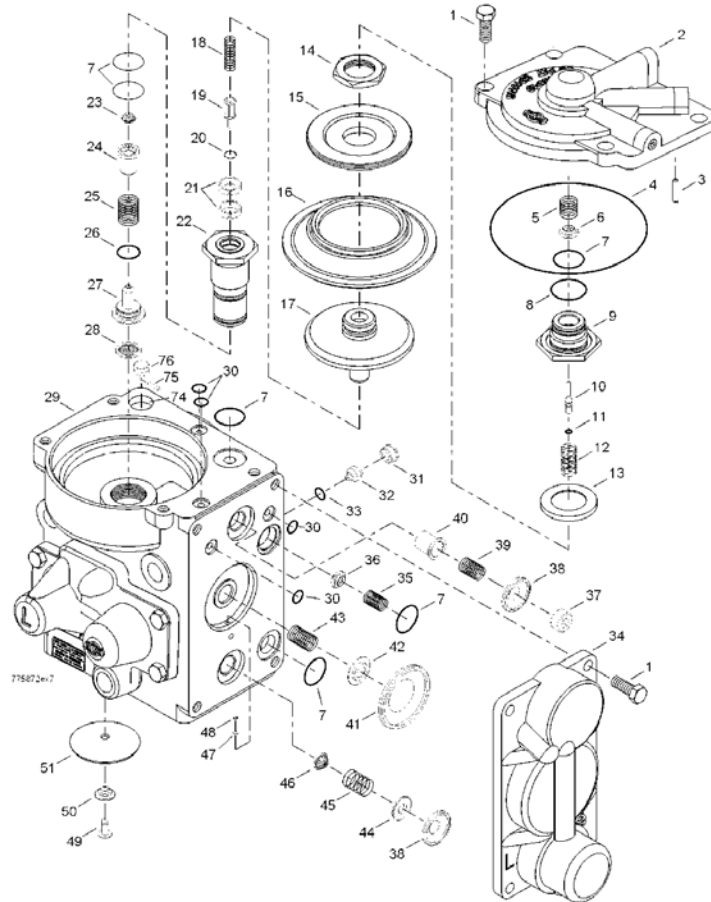
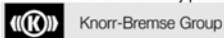

Figure 11-1 DB20 and DB20L Emergency Portion-Top and Side Cover Surfaces

Copyright 2017© NYAB. All rights reserved, including industrial property rights applications.
NYAB retains any power of disposal, such as copying and transferring.





Maintenance Specification
 DE20 and DE20L Doc.No.: NYR-429
 Emergency Portions Revision: 10 11/27/17 - en

KEY for FIGURE 11-1

Item No.	Description
1.	Cap Screw, Hex Head
2.	Top Cover Assembly
3.	Filter
4.	O-Ring
5.	Spring, Accelerated Application Sensor Valve
6.	Check Valve, Accelerated Application Sensor
7.	O-Ring
8.	O-Ring
9.	Bushing with Valve Seat and Sensor Valve Choke (C7.3)
10.	Stem, Sensor Valve (Copper alloy replaced with plastic starting with S/N E0-XXXXXX for all portions)
11.	O-Ring
*12.	Spring (Part deleted starting with S/N B0-XXXXX for P/N I85177/001D and I85177/001L)
13.	Ring
14.	Special Nut
15.	Piston Plate, Follower
16.	Diaphragm, Emergency Main Piston
17.	Piston, Emergency Main
18.	Spring, Lost Motion
19.	Stem, Lost Motion
20.	Retaining Ring
21.	Guide Ring
22.	Bushing, Threaded
23.	Check Valve, QA-Pressure Discharging Valve and High Pressure Valve
24.	Valve Guide

*When deleting spring (12), new spring (5), part number 785125, must be used.

Copyright 2017© NYAB. All rights reserved, including industrial property rights applications.
 NYAB retains any power of disposal, such as copying and transferring.



Knorr-Bremse Group

Page 55 / 71



Maintenance Specification
 DE20 and DE20L Doc-No: NYR-429
 Emergency Portions Revision: 10 11/27/17 - en

Item No.	Description
25.	Spring, QA-Pressure Discharging Valve
26.	O-Ring
27.	Bushing with Valve Seat and Emergency Sensitivity Choke (C7.2) (Replace on P/N 775871 and 775872 with S/N G0-XXXXXX)
28.	Strainer
29.	Housing Assembly
30.	O-Ring
31.	Retaining Nut w/Filter Screen
32.	Choke, QA-Chamber Charging
33.	O-Ring
34.	Side Cover Assembly
35.	Spring, Emergency Accelerated Release Check Valve
36.	Check Valve, Emergency Accelerated Release
37.	Spacer Ring (This part no longer available) (For P/N I85177/001D and I85177/001L S/N D0-XXXXX and above, part of Item 34)
38.	Diaphragm, Emergency Accelerated Release Valve and BP-Discharging Valve
39.	Spring, Emergency Accelerated Release Valve
40.	Spring Guide
41.	Diaphragm, Pulsating Valve
42.	Washer, Pulsating Valve
43.	Spring, Pulsating Valve
44.	Washer, BP-Discharging Valve
45.	Spring, BP-Discharging Valve
46.	Strainer
47.	Filter (Part deleted for P/N I85177/001D and I85177/001L starting with S/N C0-XXXXX) (Remove and discard – do not replace)

Copyright 2017© NYAB. All rights reserved, including industrial property rights applications.
 NYAB retains any power of disposal, such as copying and transferring.



Knorr-Bremse Group

Page 56 / 71



Maintenance Specification
 DB20 and DB20L Doc-No: NYR-429
 Emergency Portions Revision: 10 11/27/17 - en

Item No.	Description
48.	Retaining Ring (Part deleted for P/N I85177/001D and I85177/001L starting with S/N C0-XXXXX) (Remove and discard – do not replace)
49.	Pop Rivet
50.	Spacer Ring
51.	Vent Flap
74.	Spill Over Check Valve Bore (Bore Deleted for P/N I85177/001D & I85177/001L Starting with S/N B0-XXXXX)
75.	Steel Pin
76.	Brass Plug

NOTE

For P/N I85177/001D & I85177/001L, on valve portions without numeral '1' (see Fig. 2-4) the following parts are required in addition (See Section 7.2. "Mandatory Component Modifications"). Must replace 'spill over check valve'(bored hole - Item No. 74) with the following parts:

NOTICE

Qty.	Item No.	Name of Part	P/N
1	75	Steel Pin	773777
1	76	Brass Plug	732432

Copyright 2017© NYAB. All rights reserved, including industrial property rights applications.
 NYAB retains any power of disposal, such as copying and transferring.

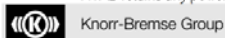



Maintenance Specification
DB20 and DB20L Doc.-No.: NYR-429
Emergency Portions Revision: 10 11/27/17 - en

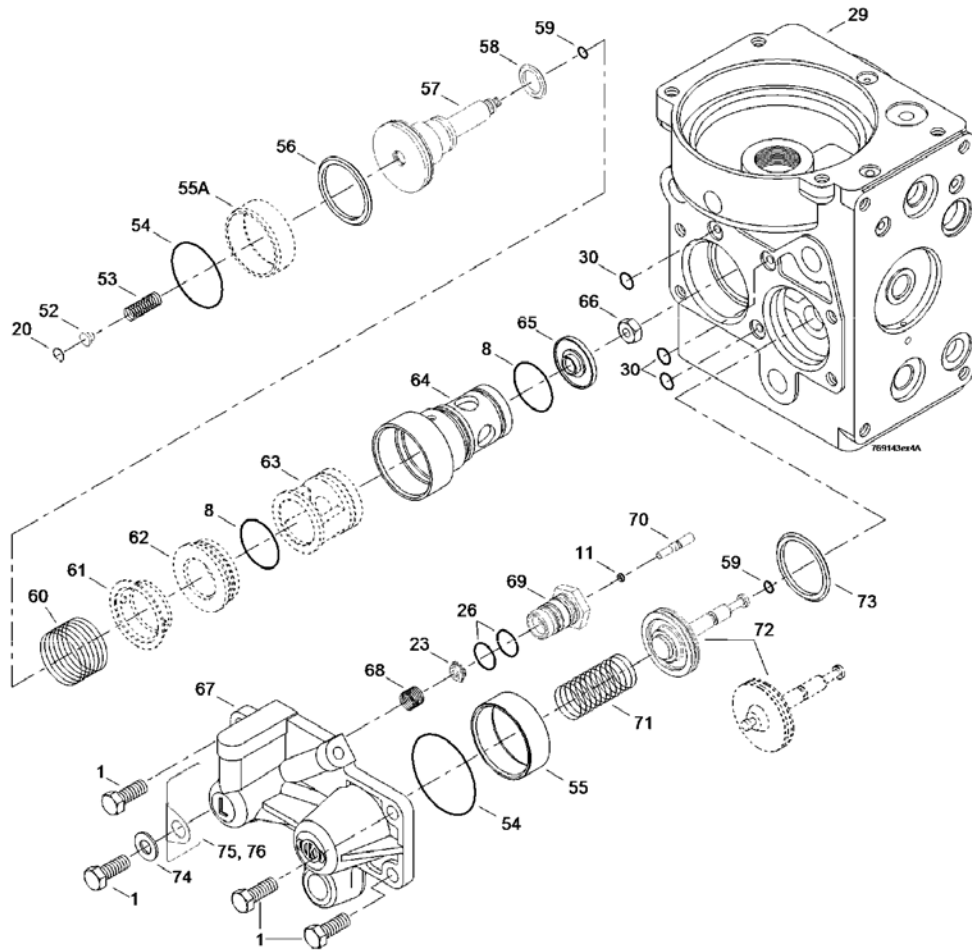

Figure 11-2 DB20 and DB20L Emergency Portion-Front Cover Surface

Copyright 2017© NYAB. All rights reserved, including industrial property rights applications.
NYAB retains any power of disposal, such as copying and transferring.



Knorr-Bremse Group

Page 58 / 71



Maintenance Specification
 DE20 and DE20L Doc.No.: NYR-429
 Emergency Portions Revision: 10 11/27/17 - en

KEY for FIGURE 11-2

Item No.	Description
1	Cap Screw, Hex Head
8	O-Ring
11	O-Ring
20	Retaining Ring
23	Check Valve, QA-Pressure Discharging Valve and High Pressure Valve
26	O-Ring
29	Housing Assembly
30	O-Ring
52	Valve Guide, Vent Valve
53	Spring, High Pressure Valve
54	O-Ring
55	Bushing, Vent Valve and Inshot Valve
55A	Bushing, Vent Valve and Inshot Valve (For P/N I85177/001D and I85177/001L S/N C0-34000 and above, part of item 64)
56	K-Ring
57	Piston Assembly, Vent Valve
58	K-Ring
59	O-Ring
60	Spring, Vent Valve Piston
61	Spacer Ring (This part no longer available) (For P/N I85177/001D and I85177/001L S/N C0-34000 and above, part of item 64)
62	Bushing, Vent Valve (This part no longer available) (For P/N I85177/001D and I85177/001L S/N C0-34000 and above, part of item 64)
63	Bushing with Valve Seat (This part no longer available) (For P/N I85177/001D and I85177/001L S/N C0-34000 and above, part of item 66)

Copyright 2017© NYAB. All rights reserved, including industrial property rights applications.
 NYAB retains any power of disposal, such as copying and transferring.



Knorr-Bremse Group

Page 59 / 71



Maintenance Specification
 DB20 and DB20L Doc-No: NYR-429
 Emergency Portions Revision: 10 11/27/17 - en

Item No.	Description
64	Bushing
65	Check Valve, Vent Valve Piston
66	Nut, Hex Lock
67	Front Cover Assembly
68	Spring, High Pressure Valve
69	Bushing, Threaded with Inshot Valve Control Choke (C10.2)
70	Stem, High Pressure Valve
71	Spring, Inshot Valve Piston
72	Piston Assembly, Inshot Valve (P/N 769356 with hole in piston, used on all portions before S/N F0-XXXXX) - to be replaced with - (P/N 778241 without hole in piston, used on portions with S/N F0-XXXXX to J0-XXXXX and L0-XXXXX to M0-XXXXX) or (P/N 785862, composite piston, used on portions starting with N0-XXXXX, as well as portions with K0-XXXXX)
73	K-Ring (used on all portions before S/N F0-XXXXX) - to be replaced with - O-Ring (used on all portions starting with S/N F0-XXXXX)
74	Flat Washer
75	CID Tag, AAR
76	CID Label, AAR

Copyright 2017© NYAB. All rights reserved, including industrial property rights applications.
 NYAB retains any power of disposal, such as copying and transferring.



Knorr-Bremse Group

Page 60 / 71



Maintenance Specification
DB20 and DB20L Doc.-No.: NYR-429
Emergency Portions Revision: 10 11/27/17 - en

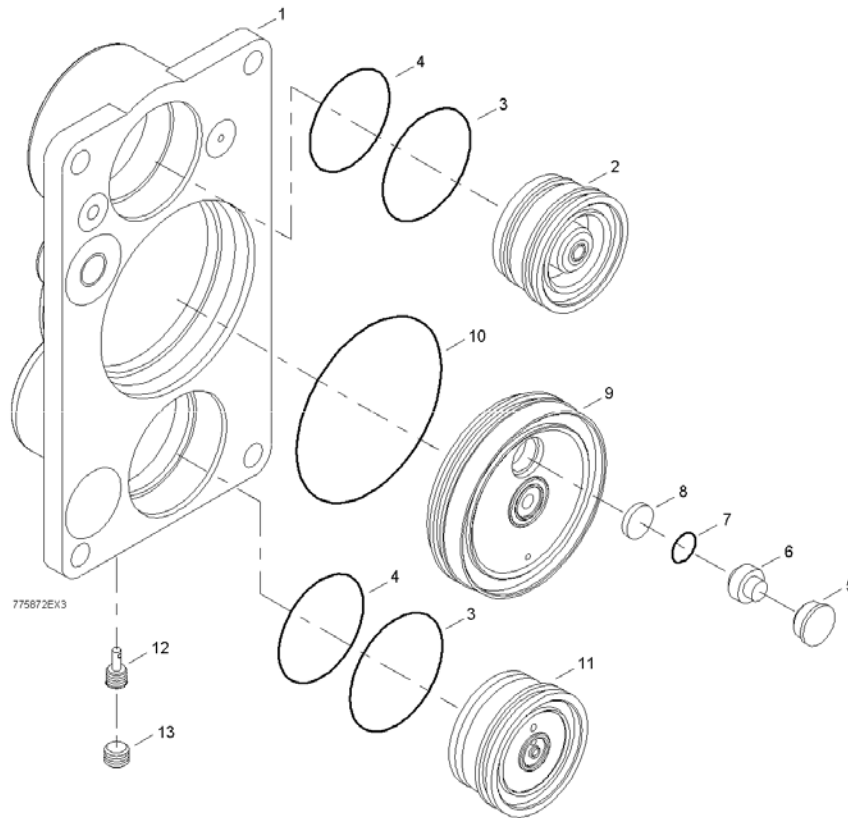
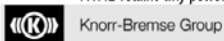

Figure 11-3 DB20 and DB20L Emergency Portion - Side Cover Assembly

Copyright 2017© NYAB. All rights reserved, including industrial property rights applications.
NYAB retains any power of disposal, such as copying and transferring.





Maintenance Specification
 DB20 and DB20L Doc-No: NYR-429
 Emergency Portions Revision: 10 11/27/17 - en

KEY for FIGURE 11-3

Item No.	Description
1	Cover
2	Bushing
3	O-Ring
4	O-Ring
5	Retaining Nut w/Filter Screen
6	Choke, Accelerated Application Sensitivity (C9.2)
7	O-Ring
8	Filter
9	Bushing
10	O-Ring
11	Bushing
12	Choke (C9.1) (DB-20 and DB-20L have different C9.1s) (See Section 7.4, Table 7-3 for correct Choke Identification)
13	Plug

NOTICE

NOTE

Side cover assemblies prior to D0-XXXXX (which do not include O-Rings 3, 4 and 10) are classified as a permanent assembly. If damaged, replace cover assembly with all new parts (1 thru 13) and make sure to discard spacer ring (37) because it was incorporated into bushing (2).

Copyright 2017© NYAB. All rights reserved, including industrial property rights applications.
 NYAB retains any power of disposal, such as copying and transferring.



Knorr-Bremse Group

Page 62 / 71



Maintenance Specification
 DB20 and DB20L Doc.No.: NYR-429
 Emergency Portions Revision: 10 11/27/17 - en

NOTICE NOTE
 Table 11-1 identifies additional parts that could potentially be replaced at a rate of 100% based on local disassembly/assembly practices.

Table 11-1 Potential 100% Replacement Parts

Fig. No.	Item No.	Description
11-1	10	Stem, Sensor Valve
11-1	13	Ring
11-1	19	Stem, Lost Motion
11-1	24	Valve Guide
11-1	40	Spring Guide
11-1	42	Washer, Pulsating Valve
11-2	69	Valve Guide
11-2	70	Stem, High Pressure Valve

Copyright 2017© NYAB. All rights reserved, including industrial property rights applications.
 NYAB retains any power of disposal, such as copying and transferring.





Maintenance Specification	
DB20 and DB20L	Doc.-No.: NYR-429
Emergency Portions	Revision: 10 11/27/17 - en

11.2 Special Tools – Drawings

(Refer to Figures 11-4 to 11-14)

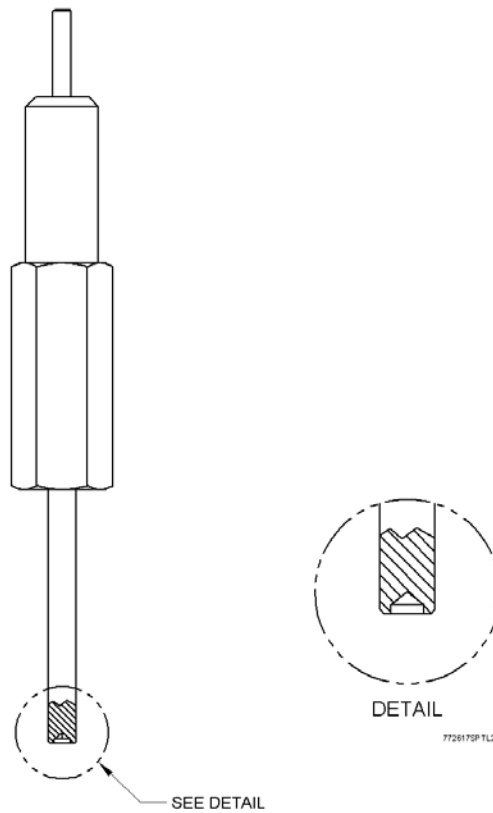

Figure 11-4 Special Hand Drive Pin (P/N 772617)

Copyright 2017© NYAB. All rights reserved, including industrial property rights applications.
NYAB retains any power of disposal, such as copying and transferring.



Knorr-Bremse Group

Page 64 / 71



Maintenance Specification
DB20 and DB20L Doc.-No.: NYR-429
Emergency Portions Revision: 10 11/27/17 - en

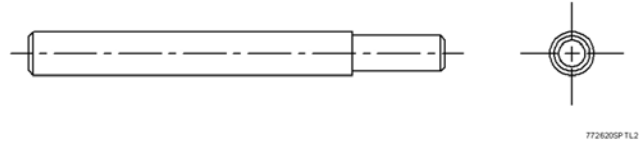

Figure 11-5 Guide Pin (P/N 772620)

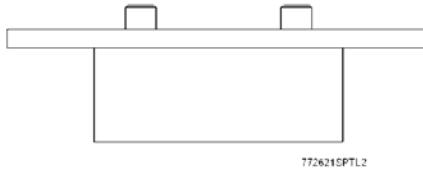

Figure 11-6 Pin-Type Fixture (Assembly) (P/N 772621)

Copyright 2017© NYAB. All rights reserved, including industrial property rights applications.
NYAB retains any power of disposal, such as copying and transferring.



Knorr-Bremse Group

Page 65 / 71



Maintenance Specification
DB20 and DB20L Doc.-No.: NYR-429
Emergency Portions Revision: 10 11/27/17 - en

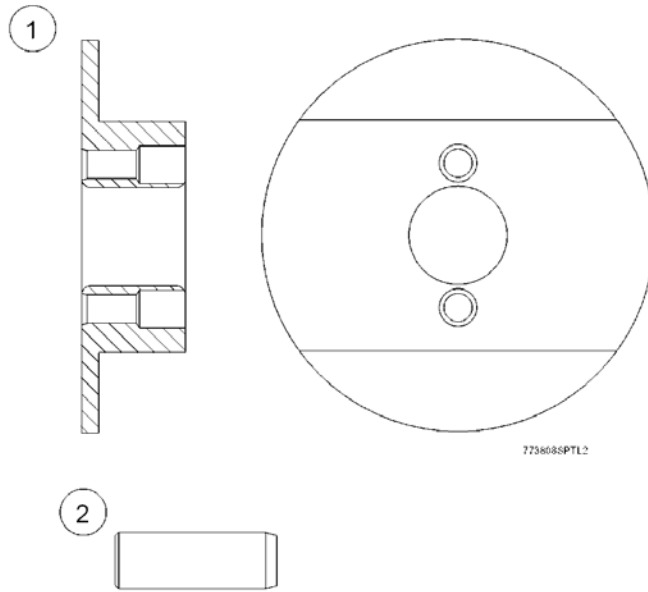

Figure 11-7 Pin-Type Fixture (Associated Parts) (P/N 773808)

Copyright 2017© NYAB. All rights reserved, including industrial property rights applications.
NYAB retains any power of disposal, such as copying and transferring.



Knorr-Bremse Group

Page 66 / 71



Maintenance Specification
DB20 and DB20L Doc.-No.: NYR-429
Emergency Portions Revision: 10 11/27/17 - en

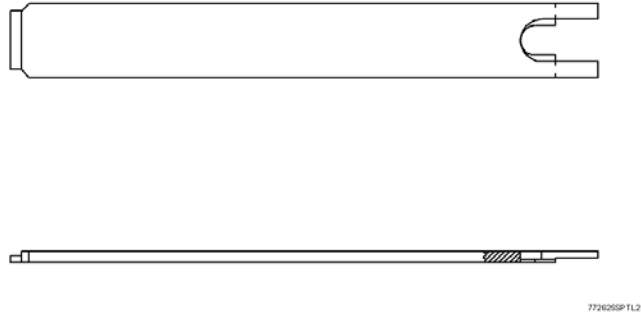

Figure 11-8 Retaining Ring Positioning Tool (P/N 772625)

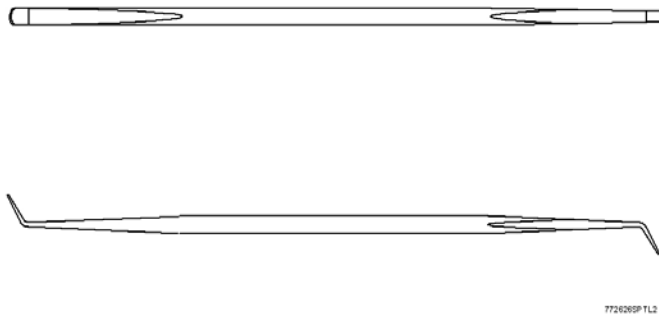

Figure 11-9 K-Ring Positioning Tool (P/N 772626)

Copyright 2017© NYAB. All rights reserved, including industrial property rights applications.
NYAB retains any power of disposal, such as copying and transferring.



Knorr-Bremse Group

Page 67 / 71



Maintenance Specification

DB20 and DB20L Doc.No.: NYR-429
Emergency Portions Revision: 10 11/27/17 - en

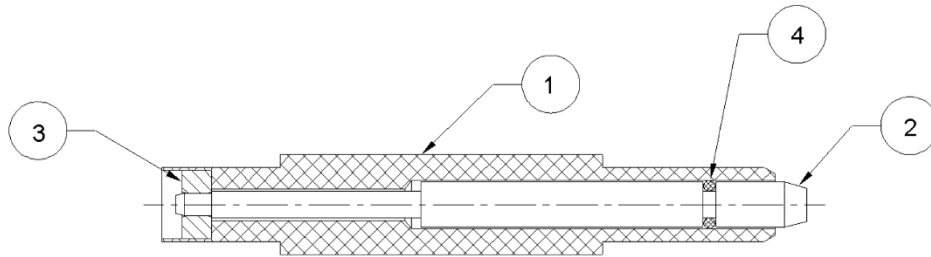

ASSEMBLY PROCEDURE:

1. ASSEMBLE PARTS 4 AND 2
2. ASSEMBLE PARTS 2 AND 1
3. PRESS PART 3 IN PLACE

772627SP 1L2

Figure 11-10 Guide Ring Assembly Tool (Assembly) (P/N 772627)

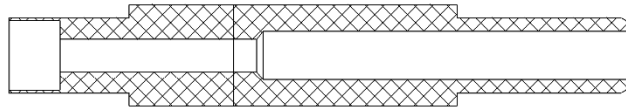

773810SPTL2

Figure 11-11 Guide Ring Assembly Tool Body (P/N 773810)

Copyright 2017© NYAB. All rights reserved, including industrial property rights applications.
NYAB retains any power of disposal, such as copying and transferring.



Knorr-Bremse Group

Page 68 / 71



Maintenance Specification

DB20 and DB20L Doc.-No.: NYR-429
Emergency Portions Revision: 10 11/27/17 - en



Figure 11-12 Guide Ring Assembly Tool Shaft and Bushing (P/N 773811 and 773812)

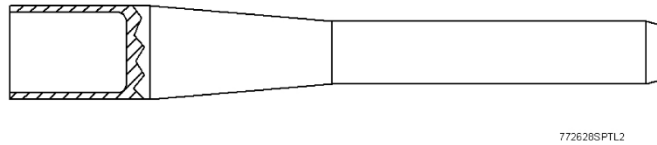

Figure 11-13 Thin-Wall Type Mandrel (P/N 772628)

Copyright 2017© NYAB. All rights reserved, including industrial property rights applications.
NYAB retains any power of disposal, such as copying and transferring.



Knorr-Bremse Group

Page 69 / 71



Maintenance Specification
DB20 and DB20L Doc.-No.: NYR-429
Emergency Portions Revision: 10 11/27/17 - en

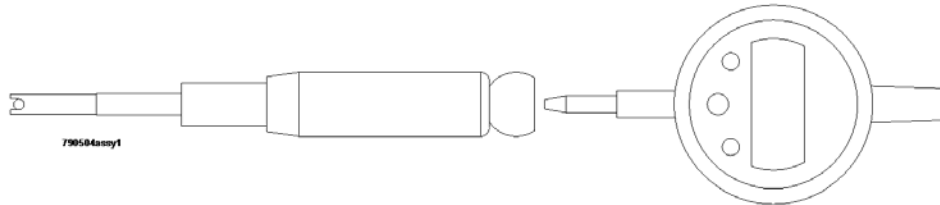

Figure 11-14 6mm Bore Gage (P/N 790504)

Copyright 2017© NYAB. All rights reserved, including industrial property rights applications.
NYAB retains any power of disposal, such as copying and transferring.



Knorr-Bremse Group

Page 70 | 71



Maintenance Specification
DB20 and DB20L Doc-No: NYR-429
Emergency Portions Revision: 10 11/27/17 - en

11.3 Abbreviations and Acronyms

AAR ASSOCIATION of AMERICAN RAILROADS
Approx..... APPROXIMATELY

BP..... BRAKE PIPE

COT&S..... CLEAN, OIL, TEST AND STENCIL
Dia..... DIAMETER

DB GERMAN FEDERAL RAILWAYS "DEUTSCHE BUNDESBAHN"

e.g..... FOR EXAMPLE

Fig FIGURE
FT-LBS..... FOOT-POUNDS

IN..... INCH
IN-LBS..... INCH-POUNDS

MAX..... MAXIMUM
MIN..... MINIMUM
MM MILLIMETER

No. NUMBER
Nm..... NEWTON-METER
NYAB..... NEW YORK AIR BRAKE

OEM..... ORIGINAL EQUIPMENT MANUFACTURING

P/N PART NUMBER
PSI..... POUNDS PER SQUARE INCH

QA..... QUALITY ASSURANCE

Ref..... REFERENCE

Copyright 2017© NYAB. All rights reserved, including industrial property rights applications.
NYAB retains any power of disposal, such as copying and transferring.



Knorr-Bremse Group

Page 71 / 71

**APPENDIX D: MERIDIAN RAIL INSTRUCTION GOVERNING INSPECTION,
MAINTENANCE AND RECLAMATION FOR AMTRAK SWING MOTION
TRUCKS, CIRCULAR NO. 5399-B, REV B**



**INSTRUCTIONS GOVERNING
INSPECTION, MAINTENANCE AND
RECLAMATION
FOR
AMTRAK
SWING MOTION TRUCKS**

CIRCULAR No. 5399-B

MERIDIAN RAIL
335 EISENHOWER LANE SOUTH
LOMBARD IL, 60148
TEL. (630) 792-2010
FAX (630) 792-1605

<u>Issue</u>	<u>Date Issued</u>
Original	February 7, 2000
Rev. A	December 15, 2000
Rev. B	April 12, 2002

**National Swing Motion Truck
 Instructions Governing Inspection
 Maintenance and Reclamation**

INTRODUCTION

The National Swing Motion Truck was designed to provide a long service life with minimum maintenance. The purpose of this circular is to advise how to prolong the service life by providing the proper maintenance and reclamation when it is required. Included in this circular are instructions on assembly and disassembly. The various parts comprising one truck are listed below and shown on page 7.

Amtrak Roadrailer Couplermate (Ass'y Drg. No's. 51617 or 53118)

6 x 11 Application

<u>Items Supplied by MeridianRail</u>	<u>Part No.</u>	<u>AAMPS Part No.</u>	<u>Qty. Per Truck</u>
Side Frame	48440-5or7	24-900-00136	2
Side Frame Column Wear Plate	50268	24-900-00330	4
Pedestal Rocker Seat	51606	24-900-00103	4
Rocker Seat Bearing	49538	24-900-00328	4
Rocker Seat	48444-1	24-900-00104	2
Bolster	48445-12		1
Bolster Wedge Pocket Wear Plate	51285-1		4
Vertical Ring Wear Liner	50033		1
Dead Lever Bracket	51290-1	24-900-00105	1
Transom	48447-4		1
Friction Wedge	51766	24-900-00005	4
Friction Wedge Spring Outer Coil	49427-1	24-900-00016	4
Friction Wedge Spring Inner Coil	49427-2	24-900-00015	4
Reverse Crown Adapter	50602	24-900-00001	4
Outer Coil Load Spring	51633	24-900-00002	8
Inner Coil Load Spring	51645	24-900-00003	8
Hold Down Spring Cup	51638	24-900-00131	8
Hold Down Spring	48450-1		8
 <u>Items Supplied by Truck Builder</u>			
1/4" Horizontal Wear Liner	50112-2		1
7/8" Auditorx Camrail Bolt & Nut	51712-1 & -2		4
Miner Side Bearings	TCC-50X		2
Bearing Retainer Assembly	51634-1,-2,-3	24-900-00004	4

5399-2

Amtrak Roadrailer Mark V (Ass'y Drg. No's. 51635 or 53124)

6 x 11 Application

<u>Items Supplied by MeridainRail</u>	<u>Part No.</u>	<u>AAMPS Part No.</u>	<u>Qty. Per Truck</u>
Side Frame	48440-5or7	24-900-00136	2
Side Frame Column Wear Plate	50268	24-900-00330	4
Pedestal Rocker Seat	51606	24-900-00103	4
Rocker Seat Bearing	49538	24-900-00328	4
Rocker Seat	48444-1	24-900-00104	2
Bolster	48445-12		1
Bolster Wedge Pocket Wear Plate	51285-1		4
Vertical Ring Wear Liner	50033		1
Dead Lever Bracket	51290-1	24-900-00105	1
Transom	48447-4		1
Friction Wedge	51766	24-900-00005	4
Friction Wedge Spring Outer Coil	49427-1	24-900-00016	4
Friction Wedge Spring Inner Coil	49427-2	24-900-00015	4
Reverse Crown Adapter	50602	24-900-00001	4
Inner Coil Load Spring	51636	24-900-00014	8
Hold Down Spring Cup	51638	24-900-00131	8
Hold Down Spring	51637	24-900-00130	8
 <u>Items Supplied by Truck Builder</u>			
Outer Coil Load Spring	D-7	24-900-00013	8
1/4" Horizontal Wear Liner	50112-2		1
7/8" Auditorx Camrail Bolt & Nut	51712-1 & -2		4
Miner Side Bearings	TCC-50X		2
Bearing Retainer Assembly	51634-1,-2,-3	24-900-00004	4

5399-3

**Amtrak 50 Ft. Express Box Cars
 Assembly No. 52623-2
 6 ½ x 12 Applications (1st Generation)**

<u>Items Supplied by MeridianRail</u>	<u>Part No.</u>	<u>AAMPS Part No.</u>	<u>Qty. Per Truck</u>
Side Frame	48677-5	24-900-00324	2
Side Frame Column Wear Plate	50268	24-900-00330	4
Pedestal Rocker Seat	51606	24-900-00103	4
Rocker Seat Bearing	49538	24-900-00328	4
Rocker Seat	52764-1	24-900-00412	2
Bolster	(1) 48680-15ASB		1
Bolster Wedge Pocket Wear Plate	51285-1		4
Vertical Ring Wear Liner	50033		1
Transom	52993	24-900-00193	1
Friction Wedge	48446	24-900-00331	4
Friction Wedge Spring Outer Coil	49427-1	24-900-00016	4
Friction Wedge Spring Inner Coil	49427-2	24-900-00015	4
Reverse Crown Adapter	51032	24-900-00332	4
Transom Bolt and Nut	51957-1 & -2		2
Damper Assembly	(2) 52871		2
<u>Items Supplied by Carbuilder</u>			
Load Spring Outer Coil	D-7	24-900-00013	10
Load Spring Inner Coil	D-7	24-900-00401	8
1/4"Horizontal Wear Liner	50112-2		1
Frame Key	43135		4
Stucki Resilient Side Bearings	656-CRH	24-900-00334	2

Notes:

- (1) When replacement of bolster is required part No. 48680-24 supercedes the 48680-15ASB.
- (2) For miscellaneous parts of the damper assembly see drg. No. 52871 or page 8 of this circular.

**Express Trak Refrigerated Car
 Assembly No. 53303
 6 ½ x 12 Applications**

<u>Items Supplied by MeridianRail</u>	<u>Part No.</u>	<u>AAMPS Part No.</u>	<u>Qty. Per Truck</u>
Side Frame	48677-5	24-900-00324	2
Side Frame Column Wear Plate	50268	24-900-00330	4
Pedestal Rocker Seat	51606	24-900-00103	4
Rocker Seat Bearing	49538	24-900-00328	4
Rocker Seat	52764-1	24-900-00412	2
Bolster	(1) 48680-25ASB		1
Bolster Wedge Pocket Wear Plate	51285-1		4
Vertical Ring Wear Liner	50033		1
Dead Lever Fulcrum Bracket	49448-1		1
Transom	52993	24-900-00193	1
Friction Wedge	48446	24-900-00331	4
Friction Wedge Spring Outer Coil	49427-1	24-900-00016	4
Friction Wedge Spring Inner Coil	49427-2	24-900-00015	4
Reverse Crown Adapter	51032	24-900-00332	4
Transom Bolt and Nut	51957-1 & -2		2
Damper Assembly	(2) 53304		2
<u>Items Supplied by Carbuilder</u>			
Load Spring Outer Coil	D-7	24-900-00013	10
Load Spring Inner Coil	D-7	24-900-00401	8
1/4"Horizontal Wear Liner	50112-2		1
Frame Key	43135		4
Stucki Resilient Side Bearings	656-CRH	24-900-00334	2

Notes:

- (1) When replacement of bolster is required part No. 48680-24 supercedes the 48680-25ASB.
- (2) For miscellaneous parts of the damper assembly see drg. No. 53304 or page 9 of this circular.

5399-5

**Amtrak 60 ft. 9 in. Express Box Cars
 Assembly drg. No. 53273-1
 6 ½ x 12 Express Car Application (2nd Generation)**

<u>Items Supplied by MeridianRail</u>	<u>Part No.</u>	<u>AAMPS Part No.</u>	<u>Qty. Per Truck</u>
Side Frame	48677-5	24-900-00324	2
Side Frame Column Wear Plate	50268	24-900-00330	4
Pedestal Rocker Seat	51606	24-900-00103	4
Rocker Seat Bearing	49538	24-900-00328	4
Rocker Seat	52764-1	24-900-00412	2
Bolster	48680-24		1
Bolster Wedge Pocket Wear Plate	51285-1		4
Vertical Ring Wear Liner	50033		1
Transom	52993	24-900-00193	1
Friction Wedge	48446	24-900-00331	4
Friction Wedge Spring Outer Coil	49427-1	24-900-00016	4
Friction Wedge Spring Inner Coil	49427-2	24-900-00015	4
Reverse Crown Adapter	51032	24-900-00332	4
Transom Bolt and Nut	51957-1 & -2		2
Damper Assembly	(1) 53272-1		2
<u>Items Supplied by Carbuilder</u>			
Load Spring Outer Coil	D-7	24-900-00013	10
Load Spring Inner Coil	D-7	24-900-00401	8
1/4"Horizontal Wear Liner	50112-2		1
Frame Key	43135		4
Stucki Resilient Side Bearings	656-CRH	24-900-00334	2

Note:

- (1) For miscellaneous parts of the damper assembly see drg. No. 53272-1 or page 10 of this circular.

NATIONAL SWING MOTION TRUCK EXPLODED VIEW OF ASSEMBLY

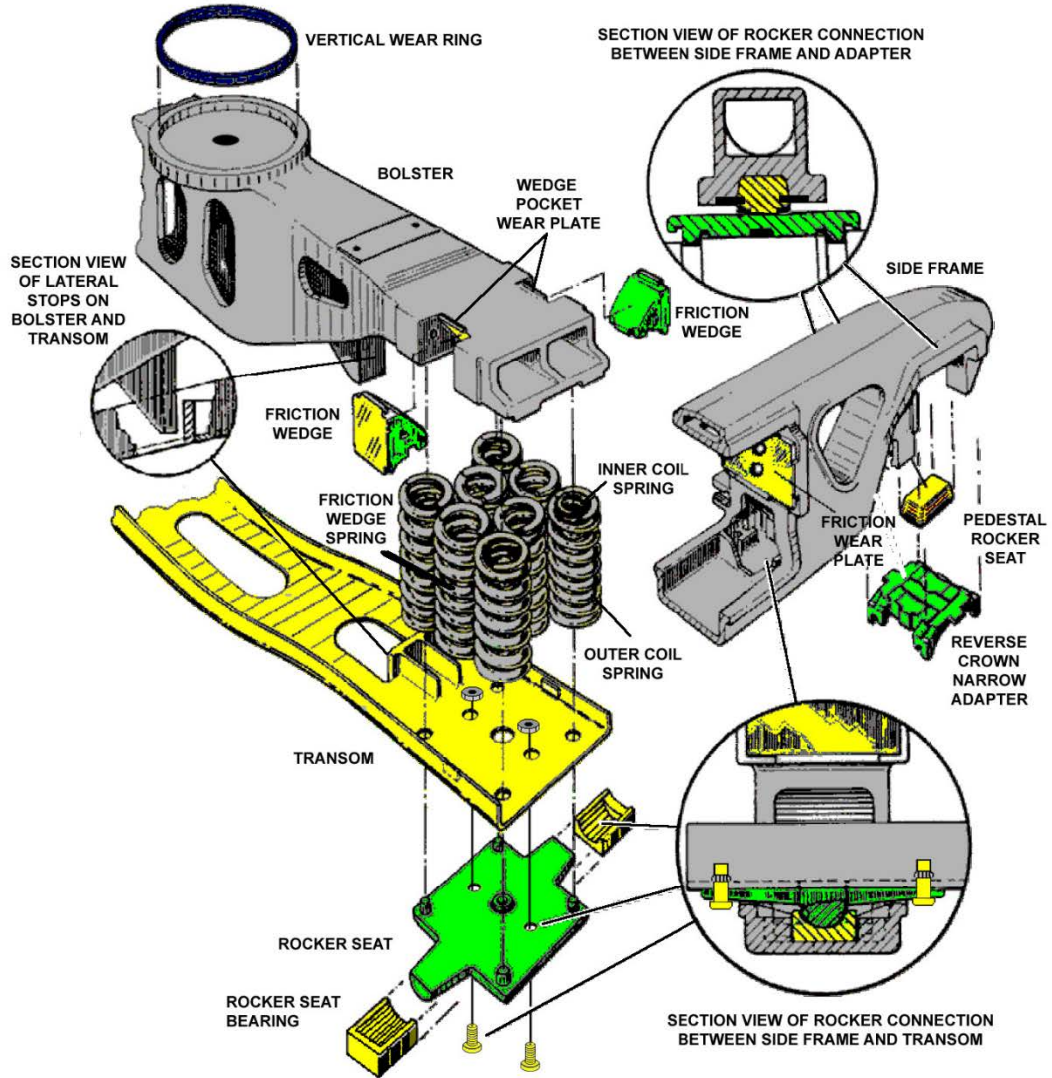

5399-7

**Express Box Car Damper Assembly No. 52871 (1st Generation)
 For Damper Assembly procedure see Circular No. 5298**

<u>Item</u>	<u>Description</u>	<u>Part No.</u>	<u>AAMPS Part No.</u>	<u>Qty. Per Truck</u>
(1)	Top Damper Bracket	52870	24-900-00399	4
(2)	Damper Lug	53037		4
(3)	Koni Vertical Damper	(1) 04A-1007-013	24-900-00402	2
(4)	Spacer	52874		4
(5)	Hex Head Bolt 1"-8UNC x 10" Long	52879-1		2
(6)	Hex Head Bolt 1"-8UNC x 7" Long	52879-2		2
(7)	Hex Head Bolt 1"-8UNC x 4" Long	52879-3		8
(8)	Hex C'sunk Screw 1"-8UNC X 4 1/2" Lg.	52879-4A		2
(9)	1" Washer	52879-5		10
(10)	1" Clipped Washer	52879-6		8
(11)	1" Hex Stop Nut (Grade 5)	52879-7		12
(12)	1" Heavy Hex Stop Nut (Grade 8)	51957-2		2
(13)	Safety Strap	53287-1		2
(14)	1" Hex Stop Nut Thin (Grade 2)	52879-10		4

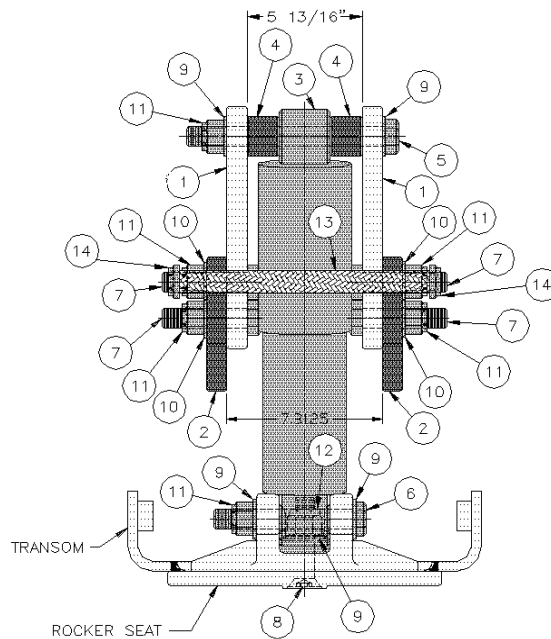

Note:

- (1) When replacement of Koni damper is required part No. 04A-1007-51 supercedes the 04A-1007-013. When one old design shock 04A-1007-013 needs replacement, then both shocks need to be changed to the 04A-1007-51 per each truck.

5399-8

Express Trak Refrigerated Damper Assembly No. 53304
For Damper Assembly procedure see Bulletin No. 540

<u>Item</u>	<u>Description</u>	<u>Part No.</u>	<u>AAMPS Part No.</u>	<u>Qty. Per Truck</u>
(1)	Top Damper Bracket	52870	24-900-00399	4
(2)	Damper Lug	53037		4
(3)	Koni Vertical Damper	04A-1007-051		2
(4)	Spacer	52874		4
(5)	Hex Head Bolt 1"-8UNC x 10" Long	52879-1		2
(6)	Clevis Pin	53245-1		2
(7)	¼" x 2" Cotter Pin	-----		2
(8)	Hex Head Bolt 1"-8UNC x 4" Long	52879-3		8
(9)	Hex C'sunk Screw 1"-8UNC X 4 ½" Lg.	52879-4A		2
(10)	1" Washer	52879-5		6
(11)	1" Clipped Washer	52879-6		8
(12)	1" Hex Stop Nut (Grade 5)	52879-7		10
(13)	1" Heavy Hex Stop Nut (Grade 8)	51957-2		2
(14)	Safety Strap	53287-1		2
(15)	1" Hex Stop Nut thin (Grade 2)	52879-10		4

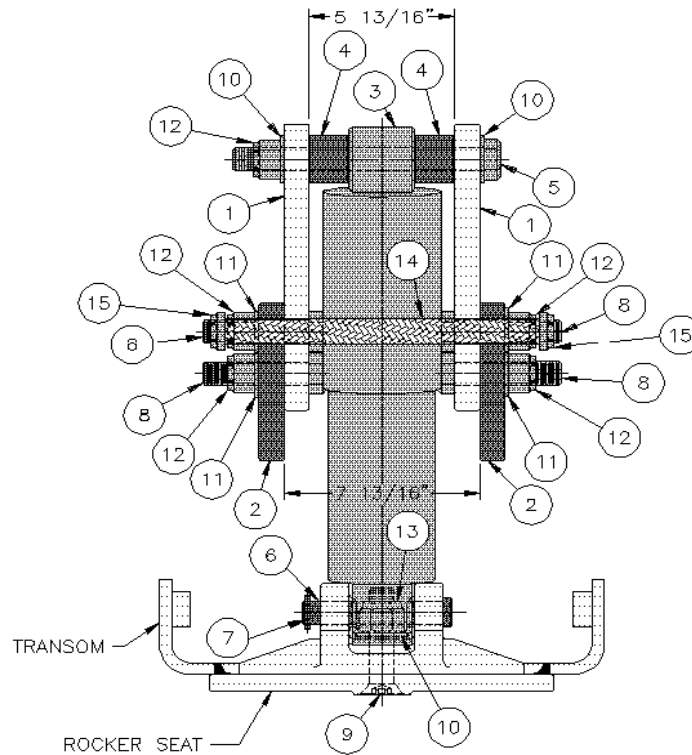

5399-9

Express Box Car Damper Assembly No. 53272-1 (2nd generation)
For Damper Assembly procedure see Bulletin No. 539-1

<u>Item</u>	<u>Description</u>	<u>Part No.</u>	<u>AAMPS Part No.</u>	<u>Qty. Per Truck</u>
(1)	Top Damper Bracket	53243		2
(2)	Koni Vertical Damper	04A-1645		2
(3)	3/4" Washer	47439-3		8
(4)	Hex Head Bolt 3/4"-16UNF X 3 1/2" Long	52879-8A		4
(5)	3/4" Hex Stop Nut (Grade 8)	52879-9		4
(6)	Hex Head Bolt 1"-8UNC x 4" Long	52879-3		8
(7)	Hex C'sunk Screw 1"-8UNC X 4 1/2" Lg.	52879-4A		2
(8)	1" Washer	52879-5		6
(9)	1" Clipped Washer	52879-6		8
(10)	1" Hex Stop Nut (Grade 5)	52879-7		10
(11)	1" Heavy Hex Stop Nut (Grade 8)	51957-2		2
(12)	Hex Head Bolt 1"-8UNC x 7" Long	52879-2		2
(13)	Safety Strap	53287-1		2
(14)	1" Hex Stop Nut thin (Grade 2)	52879-10		4

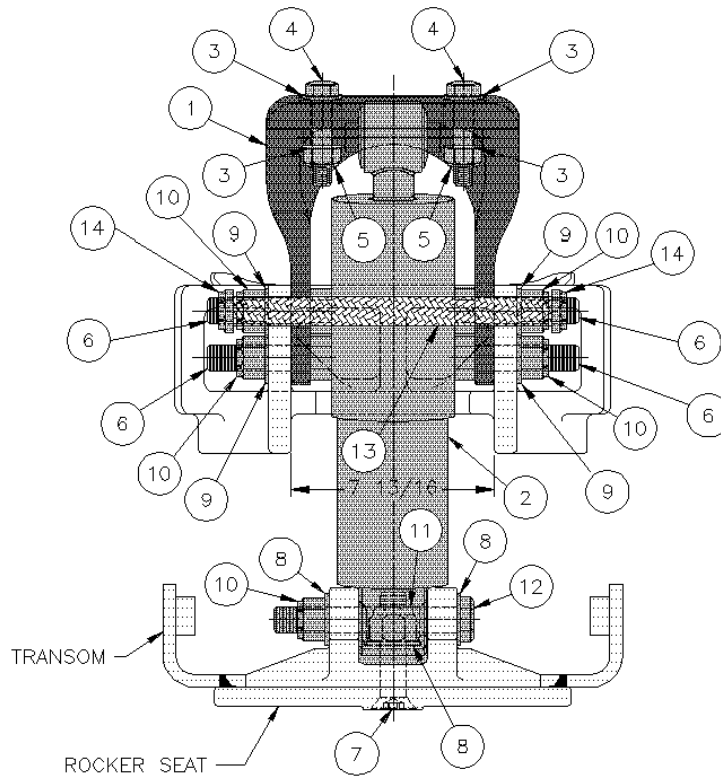

5399-10

INSPECTION & MAINTENANCE

Part 1

A. TRUCK INSPECTION PRIOR TO DETRUCKING FROM CAR

1. Damping Control Wear Indicator

Proper damping is essential in controlling truck performance. Application of Gage No. 51555 will determine if maintenance is required. As shown in Figure 1 when gage seats on both friction wedge shoulders and does not contact top surface of bolster end maintenance is required. When wedge shoulders are below gage when gage is resting on top surface of bolster end no maintenance of damping system is required.

Damping Control Wear Indicator

Gage No. 51555

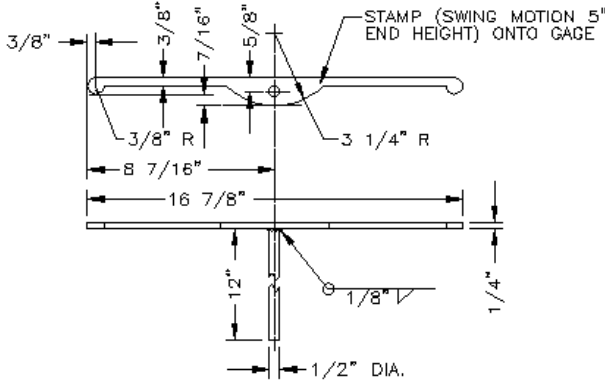

MATERIAL: COLD ROLLED STEEL

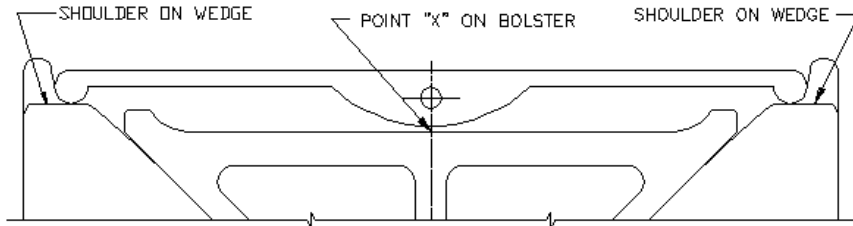

Fig. 1

Note: When gage seats on both friction wedge shoulders and does not contact bolster at point "X" repair is required.

5399-11

2. Friction Wedges

Friction wedges may be inspected for wear without disassembling the truck. Inspection of the wear limit notches on steel wedges at the top and bottom of the front face of friction surface will determine if wedge replacement is required, see Figure 2.

Friction wedges with composition liner material on front face of the wedges need to be replaced if liner material measures 1/8 in. or less in thickness.

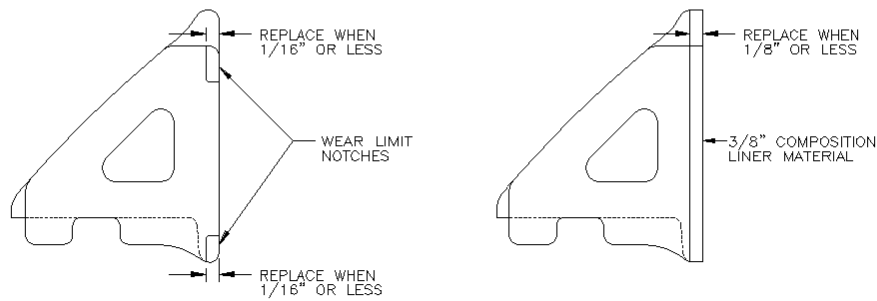

Fig. 2

**All Steel Wedge
 (Express Cars)**

**Composition Liner Wedge
 (Couplermate & Mark V)
 RoadRailer**

3. Side Frame Lateral Swing Capability

Another important design feature of swing motion truck is the ability of side frames to swing laterally.

- 3.a. Inspection of available clearance between underside of rocker seat and raised pads on side frame tension member is required. A 3/32 in. thick feeler must pass thru rocker seat and raised pad on tension member when side frames are in neutral position (side frames are to be perpendicular to top of track rails), see Figure 3. When 3/32 in. feeler does not pass thru maintenance is required. See Section C Paragraph 4.

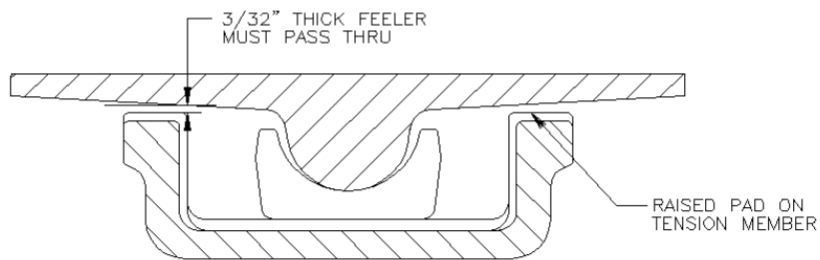

Fig. 3

5399-12

- 3.b. Inspection of the pedestal rocker seat is also required. However, this requires detrucking from car. Lift entire truck assembly at side frames from wheel and axle sets.

When inspecting pedestal rocker seat the crown surface will have developed a contact area. When this contact area width measures more than 2½ in. wide pedestal rocker seat needs to be replaced. On latest design pedestal rocker seat part no. 51606 a visual indication would be width of center portion, see Figure 4

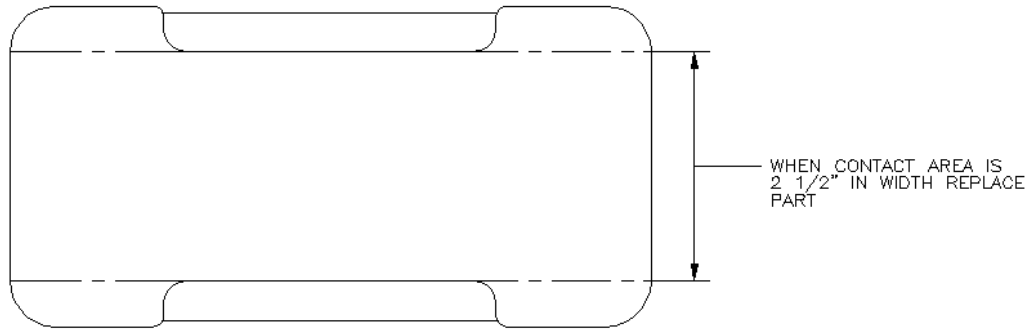

Fig. 4

4. National Reverse Crown Adapter

Inspection of adapters are to be in accordance with A.A.R. interchange rules as outlined in Rule 37. When replacement parts are required see bill of material on pages 2 thru 6 of this circular for proper MeridianRail part numbers.

B. Truck Disassembly

Truck disassembly is accomplished as described in the following steps. For further information see Product Bulletin No. AMTK-532 "Swing Motion Truck Parts and Assembly".

1. Remove vertical damper and top damper brackets.
2. Insert 5/8" diameter retainer pin in bolster end to hold friction wedges in place.
3. Raise bolster to top of frame and remove front load springs and friction wedge springs.
4. Remove friction wedges from bolster by pulling retaining pins and remove wedges.
5. Remove rear load springs.
6. Unbolt transom from rocker seat
7. Lift bolster and transom together until transom holes disengage from rocker seats. Remove side frame with their rocker seat assemblies, together from bolster and transom.
8. Remove rocker seats and rocker seat bearings from side frames.

5399-13

2. Friction Wedge Springs

Friction wedge springs should be inspected for breakage and permanent set whenever the wedge springs are removed. Broken wedge springs must be replaced. When truck load springs are being replaced for excessive corrosion or pitting per A.A.R. interchange rule 50, wedge springs should also be replaced. Wedge springs must be replaced if the load springs are being replaced for condemning height even if the wedge spring did not reach condemning height.

2.a. Condemning Limit for Permanent Set

Standard 6 x 11 & 6 1/2 x 12 Trucks	Nominal New Free Height	Condemning Free Height
Outer Wedge Spring 49427-1	11 5/16"	10 11/16"
Inner Wedge Spring 49427-2	10 13/16"	10 3/16"

3. Truck Load Springs

Truck load springs should be inspected for breakage and permanent set per A.A.R. interchange rule 50, when A.A.R. designation springs are being used.

When truck suspension is equipped with a dual rate system the hold down springs and hold down spring cups should be inspected for breakage and for excessive wear or deformation.

3.a. Condemning Limit for Permanent Set of Dual Rate Spring.

Standard 6 x 11 & 6 1/2 x 12 Trucks	Nominal New Free Height	Condemning Free Height
Outer Load Spring 51633	11 1/16"	10 9/16"
Inner Load Spring 51645	8 7/16"	8 1/16"
Hold Down Spring 48450-1	5 1/2"	5 1/4"
Inner Load Spring 51636	7 1/16"	6 13/16"
Hold Down Spring 51637	7 7/16"	7 3/16"

4. Rocker Seats and Rocker Seat Bearings

Field service inspection has shown a minimal amount of wear occurs between these parts, therefore, they should provide many years of maintenance free service.

The rocker seats and rocker seat bearings should be inspected for wear of the bearing surfaces which are indicated in Figure 6 and Figure 7.

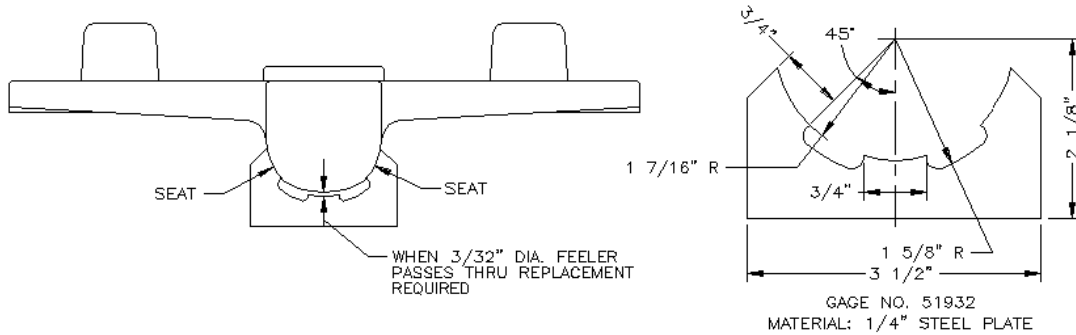

Fig. 6

Apply Gage No. 51932 to both trunions on rocker seats. When a 3/32" dia. feeler passes thru rocker seat and gage center leg, replacement of rocker seat is required.

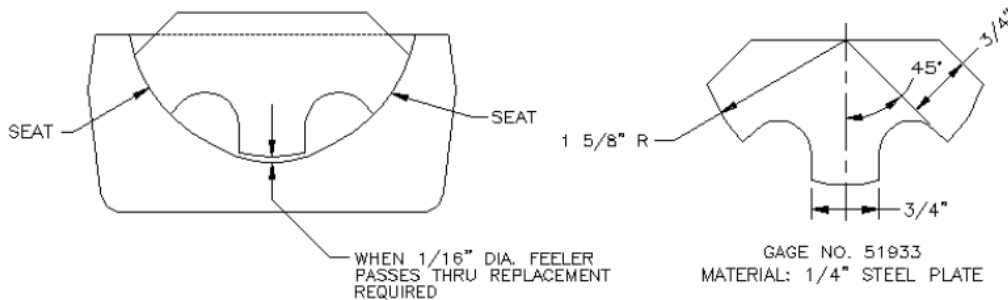

Fig. 7

Apply Gage No. 51933 to rocker seat bearings as shown in Figure 7. When a 1/16" dia. feeler passes thru rocker seat bearing and gage center leg, replacement of rocker seat bearings is required.

5399-16

5. Side Frame Columns

Inspection of the wear plates should include a visual examination of both the welds and the wear plates for cracks. Wear plates with cracks or which are 1/4 in. or less in thickness should be replaced. Inspection of wear plate retainer lugs is required when the distance between columns, as shown in Figure 8, reaches 17 1/2 in. or more, indicating 1/4 in. wear per side. These surfaces must be restored as outlined in Part II reclamation.

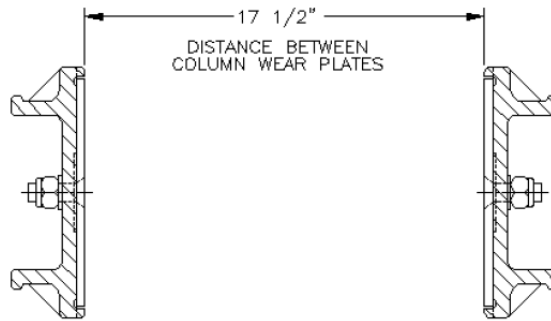

Fig. 8

6. Bolster End Sides

Field service inspections have shown a minimal amount of wear occurs across the bolster lands. Measure distance across the end of the bolster, both inboard and outboard of wedge pocket. When this distance measures 16 5/16 in. or less, as shown in Figure 9, indicating 1/4 in. wear per side, these surfaces must be restored as outlined in Part II reclamation.

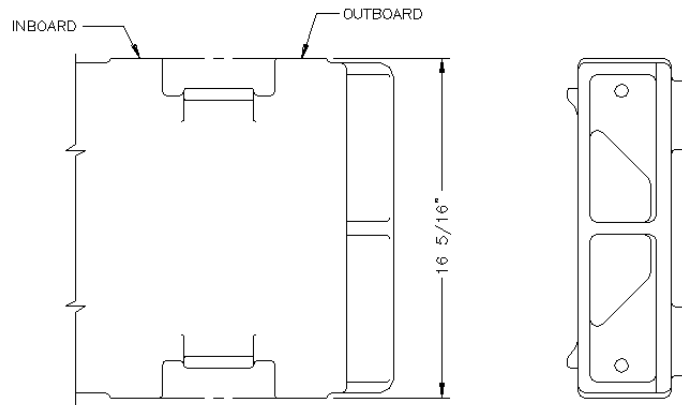

Fig. 9

5399-17

7. Bolster Wedge Pocket

The wedge pocket slope surface is designed for stainless steel wear plate application or an as cast surface. Gage No. 51436 is used for either design surfaces to determine the depth of wear.

Apply Gage No. 51436 to bolster spring seat with gage centered approximately between two scribed lines. When the depth of wear on the sloped surface, as shown in Figure 10 reaches 1/4 in. or more, these surfaces must be restored as outlined in Part II reclamation.

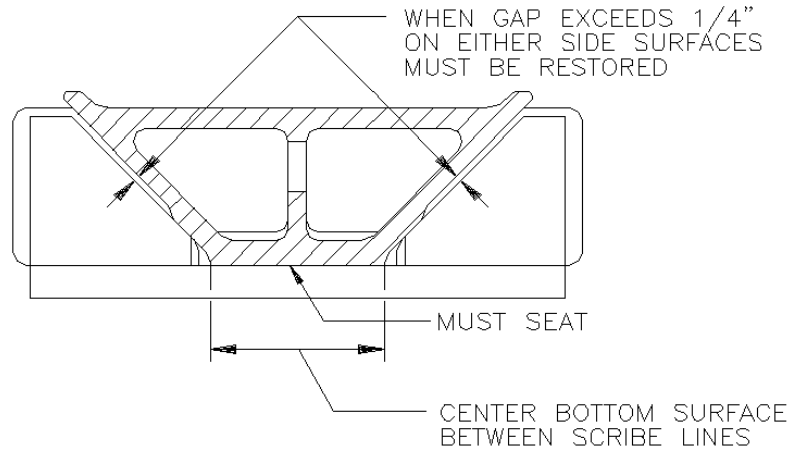
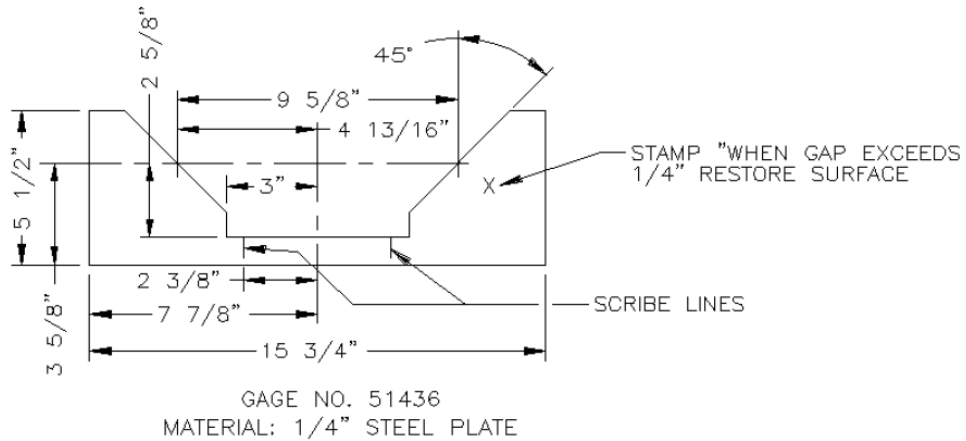

Fig. 10



5399-18

8. Transom

Although it is very unlikely, there is a slight possibility of damage as a result of hitting an obstruction on the track. The transom should be inspected for cracks or excessive deformation. If there is any crack transverse or longitudinal, The transom should be replaced. Excessively deformed transom should be replaced. Some transoms might have special spring retainers, rings or bosses on them. These should be visually inspected for cracked welds or loose parts. These parts may be rewelded as required.

9. Inspection of remaining wear areas of side frames and bolsters are to be in accordance with A.A.R. Spec. No. M-214.

PART II
RECLAMATION

Side frames and bolsters may, after many years of service, require a certain amount of reclamation. The main areas of wear to these parts are as follows:

- A. Pedestal roof rocker seats
- B. Cracked, missing or worn wear plates
- *C. Side frame columns
- *D. Side frame thrust lugs
- *E. Side frame pedestal legs
- *F. Bolster wedge pockets
- *G. Bolster end sides

*These areas may be reclaimed by building up worn surfaces to original drawing dimensions per A.A.R. spec. M-214. Welding operations referred to herein should be in accordance with A.A.R. spec. M-214 regarding weld repair of Grade B, Grade B+ or Grade C steel castings.

Description	Nominal Dimension	Tolerance
Side Frame Columns	17"	+1/8" – 1/16"
Side Frame Thrust Lug Width	3 1/2"	+ 1/16" – 3/32"
6 x 11 S.F. Thrust Lug Opening	7 1/4"	+3/32" – 1/32"
6 1/2 x 12 S.F. Thrust Lug Opening	7 3/4"	+3/32" – 1/32"
6 x 11 Pedestal Leg Opening	8 7/8"	+ 1/8" – 0"
6 1/2 x 12 Pedestal Leg Opening	10 1/8"	+1/8" – 0"
Bolster Wedge Pockets	9 1/2"	+ 1/8" – 0"
Bolster End Sides	16 13/16"	+ 1/16" – 1/16"

5399-20

A. Side Frame
 1. Pedestal Rocker Seat

Side frame must be placed upside down on compression side so that the pedestal rocker seat "flat side" can be placed into the pedestal jaw (must seat without rocking) and position for downhand welding. Place spacer part no. (See table) between the pedestal rocker seat and the side wall of the rocker seat pocket at the two weld locations. Use equal shim thickness up to 1/8" to each side of rocker seat to achieve 1/16" maximum lateral clearance of assembly. Place retainer plates no. 51606-1 in cavity adjacent to pedestal rocker seat pocket. Clamp retainer plates in place prior to welding, see Figure 11.

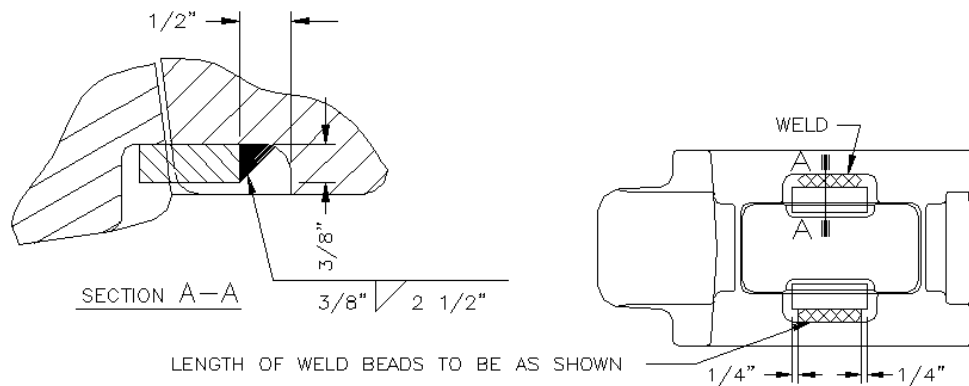
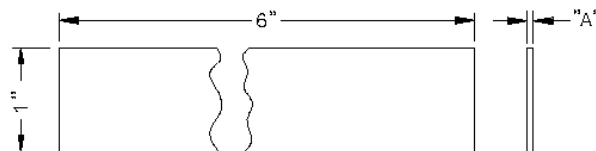

Fig. 11



SPACER
 PART NO. SEE TABLE
 MATERIAL: MILD STEEL

GAGE NO.	"A"
51606-3	1/32"
51606-4	1/16"
51606-5	3/32"
51606-6	1/8"

5399-21

2. Column Wear Plates

Secure friction wear plates to side frame columns before welding with approved fasteners which will produce a minimum clamping force of 28,000 lbs. Weld wear plate with 2 point weld locations as was supplied by OEM. Build up of retaining lugs by welding must not project beyond wear plate face. Remove any weld splatter from the wear plate surface and grind flush any projection beyond the wear plate surface. Apply gage No. 51934 to ensure proper column opening as shown in Figure 12. for entire column height.



Fig. 12

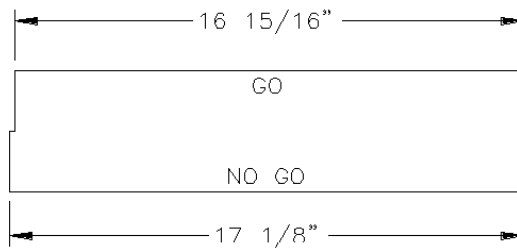

GAGE NO. 51934
MATERIAL: 1/4" STEEL PLATE

5399-22

B. Bolster

1. Wedge Pocket Wear Plate Application

Welding. Place wear plate with back surface of plate seated firmly in pocket and seating on retainer lug, secure with clamp prior to welding. Weld in 3 locations as shown in Figure 13 using welding rod ASTM E-308, 309, 310 or equivalent (stainless steel). Avoid over-heating due to slow arc travel.

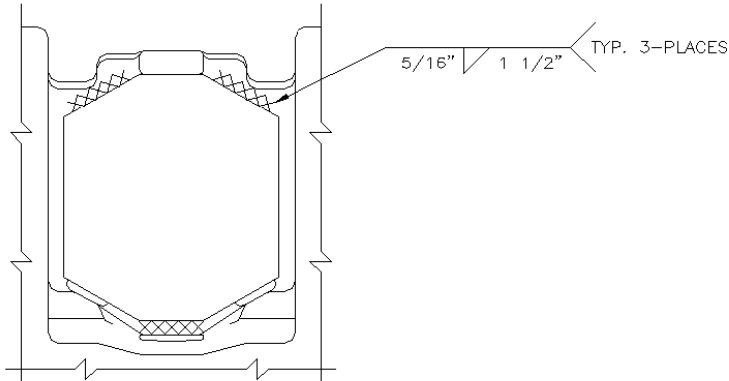

Fig. 13

2. Apply Gage No. 51436 to bolster spring seat with gage centered approximately between two scribed lines. Gage sloped surface may contact or 1/16" max. clearance on either side, see Figure 14.

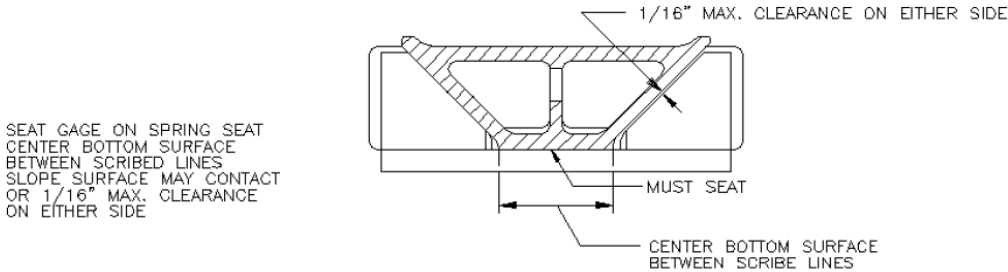

Fig. 14

5399-23

3. Bolster End Sides

These surfaces are to be restored following practices outlined in A.A.R. Spec. M-214. Apply Gage No. 48468-1 to ensure proper width of bolster end sides, see Figure 15.

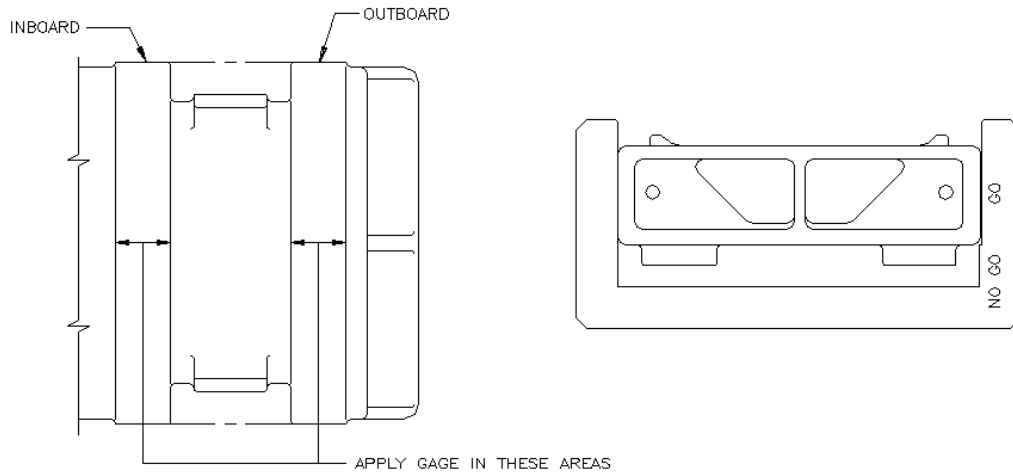
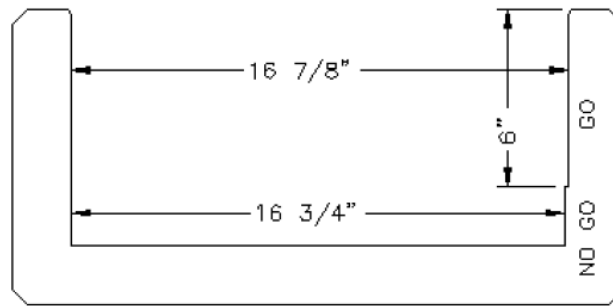

Fig. 15



GAGE NO. 48468-1
 MATERIAL: 1/4\" STEEL PLATE

- C. All other restoration of bolster and side frame such as, center plate bowl, thrust lugs, etc., are to be done in accordance with A.A.R. Spec. M-214.

5399-24

PART III
TRUCK ASSEMBLY

A. Side Frame

Place both rocker seat bearings into pockets in side frame. Rocker seat bearings must seat properly (rocker seat bearings should not rock). Place rocker seat into side frame and check for available clearance for rocker seat to rock. This can be done by tilting rocker seat until it contacts the raised pads on tension member. Apply Gage No. 49706 at raised pad areas to open side as shown in Figure 16. When the thin leg of gage enters opening and seats on side wall of frame, clearance is sufficient. When the thick leg of gage enters opening, the gage should not come in contact with side wall of frame. If gage does come in contact, clearance is excessive. Tilting of rocker seat should be done in both directions, inboard and outboard. Restoration of proper clearance can be achieved by addition of shims under the rocker seat bearings, see Figure 17 for dimension of shims.

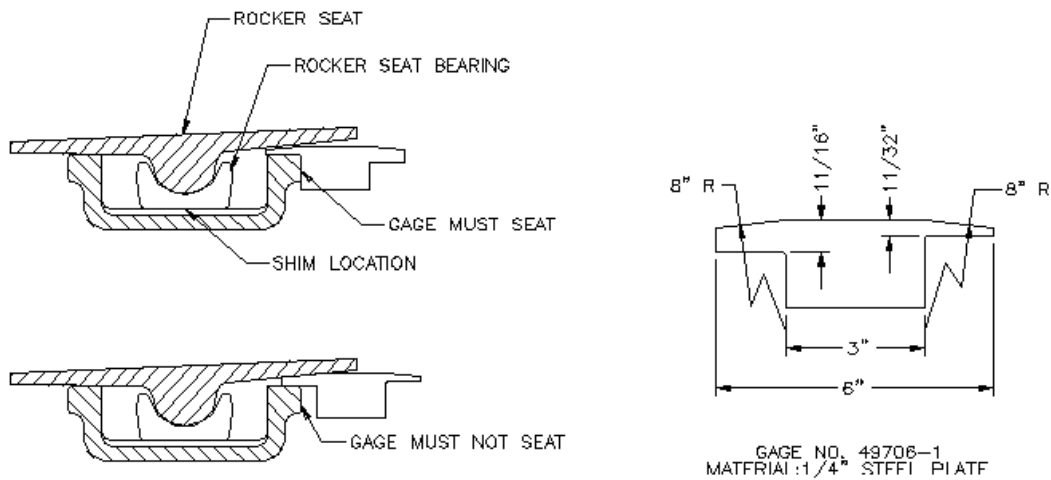

Fig. 16

5399-25

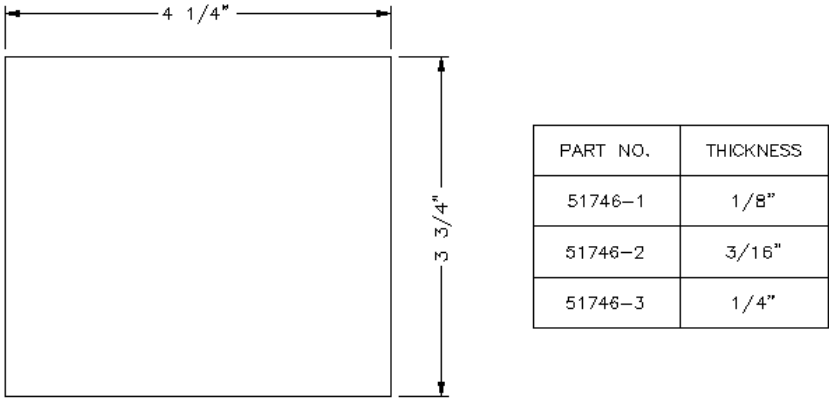

Fig. 17

B. Truck Assembly

1. Truck assembly is the reverse procedure of the truck disassembly described in the first part of this circular. Care must be taken to assure that all parts are put back into proper operating position. For further information see Product Bulletin No. AMTK-532 "Swing Motion Truck Parts and Assembly".
2. The load spring arrangements for 6 x 11 and 6 1/2 x 12 trucks are shown in Figure 18.

Note: Use standard unit wear plate in the side frame as shown in A.A.R. standard S-367 latest rev. **Do not** use self-centering wear plates.

**Amtrak Swing Motion
 Spring Group Arrangements**

Description	Outer Load Spring	Inner Load Spring	Hold Down Spring Cup	Hold Down Spring	Outer Wedge Spring	Inner Wedge Spring
RoadRailer Couplermate	Four 51633	Four 51645	Four 51638	Four 48450-1	Two 49427-1	Two 49427-2
RoadRailer Mark V	Four AAR D7 Outer	Four 51636	Four 51638	Four 51637	Two 49427-1	Two 49427-2
Express Boxcar	Five AAR D7 Outer	Four AAR D7 Inner			Two 49427-1	Two 49427-2

Spring Descriptions

Description	Height (In)	Outer Dia. (In)	Inner Dia. (In)	Wire Dia. (In)
AAR D7 Outer	10 13/16	5 1/2	3 5/8	15/16
AAR D7 Inner	10 3/4	3 1/2	2 1/4	5/8
48450-1	5 1/2	1.224	.870	.177
49427-1	11 5/16	4 7/8	3 1/4	13/16
49427-2	10 13/16	3 1/8	2	9/16
51633	11 1/16	5 1/2	4	3/4
51636	7 1/16	3 1/2	1 7/8	13/16
51637	7 7/16	1.224	.900	.162
51645	8 7/16	3 11/16	2 5/16	11/16

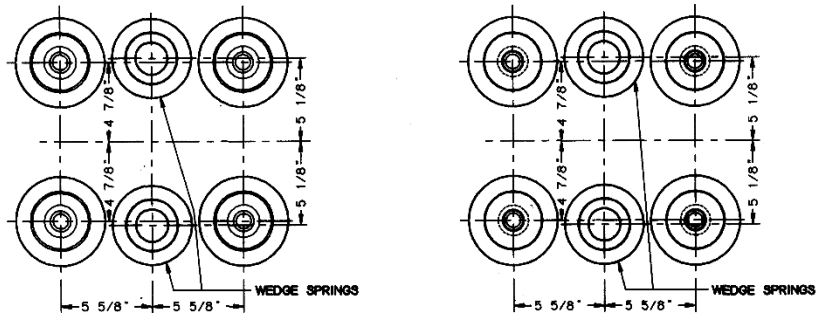

Roadrailer Couplermate

Fig. 18

Roadrailer Mark V

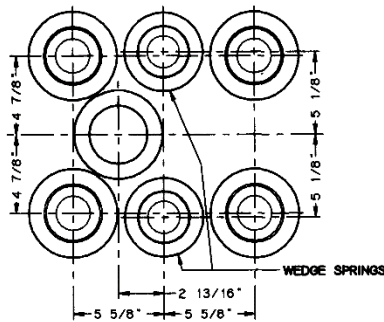

Express Cars

5399-27

Assembly of a dual rate spring application is shown in Figure 19.

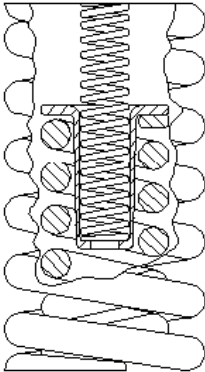

Fig. 19

List of gages used in this Circular

(For both 6 x 11 and 6 ½ x 12 trucks)

Gage No.	Description
51555	Damping control wear indicator
51932	Rocker Seat Trunion
51933	Rocker Seat Bearing
51436	Bolster Wedge Pocket slope surface
51934	Side Frame column opening
48468-1	Bolster end sides
49706-1	Rocker Seat clearance

Issue	Date	Description
A	Dec. 15, 2000	Pedestal rocker seat shimming procedure changed.
B	April 12, 2002	2 nd generation Express Box & Express Trak Refrigerator Cars Information added.