



**United States of America**

**Third National Report**

**for the**

**Joint Convention on the Safety of**

**Spent Fuel Management and on**

**the Safety of Radioactive Waste**

**Management**

United States Department of Energy

In Cooperation with the  
United States Nuclear Regulatory Commission  
United States Environmental Protection Agency  
United States Department of State

This page intentionally left blank

## ABSTRACT AND ACKNOWLEDGEMENT

The United States of America ratified the *Joint Convention on the Safety of Spent Fuel Management and on the Safety of Radioactive Waste Management* (Joint Convention) on April 9, 2003. The Joint Convention establishes an international peer review process among Contracting Parties and provides incentives for nations to take appropriate steps to bring their nuclear activities into compliance with general safety standards and practices. The United States participated in Review Meetings of the Contracting Parties to the Joint Convention in November 2003, and May 2006, in Vienna, Austria. This Third report, an update of the U.S. National Report prepared under the Joint Convention in October 2008, documents spent fuel and radioactive waste management safety in the United States under the terms of the Joint Convention. It was prepared by the U.S. Government for review by the Contracting Parties.

The United States is in compliance with the terms of the Joint Convention. An extensive U.S. legal and regulatory structure ensures the safety of spent fuel and radioactive waste management. The report describes radioactive waste management in the United States in both commercial and government sectors, and provides annexes with information on spent fuel and waste management facilities, inventories, and ongoing decommissioning projects. It also provides detailed information on spent fuel and radioactive waste management safety, as well as transboundary movements (imports/exports) and disused sealed sources, as required by the Joint Convention.

The U.S. Department of Energy acknowledges the support and cooperation of the U.S. Environmental Protection Agency, U.S. Nuclear Regulatory Commission, and U.S. Department of State in preparation of this report through the Joint Convention Interagency Executive Steering Committee and Working Group. The information in this report was extracted from publicly available information sources, including regulations and internet web sites of these agencies.

Copies of this report are available from:

United States Department of Energy  
Center for Environmental Management Information  
Office of Environmental Management  
1000 Independence Avenue, SW  
Washington, DC 20585

Mr. Douglas Tonkay  
United States Department of Energy  
Mailstop EM-12/Cloverleaf Building  
1000 Independence Avenue, SW  
Washington, DC 20585  
Email: [douglas.tonkay@em.doe.gov](mailto:douglas.tonkay@em.doe.gov)

## TABLE OF CONTENTS

A. INTRODUCTION.....	1
A.1 Purpose and Structure of this Report .....	1
A.2 Summary Results from the Previous Review .....	4
A.3 What's New Since Last Report.....	5
B. POLICIES AND PRACTICES.....	11
B.1 U.S. National Policy on Nuclear Activities .....	11
B.2 Government and Commercial Entities.....	12
B.2.1 Government Sector .....	12
B.2.2 Commercial Sector .....	13
B.2.3 Classification of Spent Fuel and Radioactive Waste.....	13
B.2.3.1 Spent Fuel.....	13
B.2.3.2 Radioactive Waste .....	13
B.2.3.3 Other Regulated Radioactive Materials .....	15
B.3 Spent Fuel Management Practices .....	16
B.3.1 Spent Fuel Storage.....	16
B.3.2 Spent Fuel Disposal .....	16
B.3.3 Waste Confidence Determination.....	17
B.3.4 Reprocessing in the United States .....	17
B.4 Radioactive Waste Management Practices.....	18
B.4.1 Low-Level Waste .....	18
B.4.2 Transuranic Waste .....	18
B.4.3 High-Level Waste .....	18
B.4.4 Uranium Recovery .....	19
B.4.5 Waste from Enrichment and Fuel Fabrication Facilities .....	19
B.4.6 Ocean Disposal .....	20
B.5 Decommissioning .....	21
C. SCOPE OF APPLICATION.....	23
C.1 Application to Reprocessing of Spent Fuel .....	23
C.2 Application to Naturally Occurring Radioactive Materials .....	23
C.3 Application to Defense Activities .....	23
C.4 Application to Radioactive Waste and Spent Fuel Management Facilities .....	24
D. INVENTORIES AND LISTS .....	25
D.1 Spent Fuel Management .....	25
D.1.1 Spent Fuel Storage.....	25
D.1.2 Spent Fuel Disposal .....	28
D.2 Radioactive Waste Management.....	30
D.2.1 Radioactive Waste Storage and Treatment .....	30
D.2.1.1 HLW Storage and Treatment.....	31
D.2.1.2 Greater-Than-Class C Low-Level Waste Management.....	32
D.2.1.3 LLW Storage and Treatment .....	33
D.2.2 Radioactive Waste Disposal.....	33
D.2.2.1 Transuranic Waste Disposal.....	34
D.2.2.2 Low-Level Waste (Near Surface) Disposal.....	35
D.2.2.3 Uranium Mill Tailings Disposal.....	37
D.2.2.3.1 UMTRCA Title I Mill Tailings Sites .....	37
D.2.2.3.2 UMTRCA Title II Licensed Uranium Recovery Facilities/Mill Tailings Sites .....	38
D.2.2.4 Mine Overburden Remediation .....	39
D.3 Nuclear Facility Decommissioning.....	40
D.3.1 DOE Sites with Decommissioning/Remediation Projects .....	41
D.3.2 Formerly Utilized Sites Remedial Action Program .....	42
D.3.3 Complex Materials Sites Decommissioning (NRC).....	43
D.3.3.1 Complex Decommissioning Sites Regulated by NRC Agreement States .....	43
D.3.3.2 Power and Non-Power Reactor Decommissioning .....	43
D.3.3.3 Other Non-Power Facility Decommissioning .....	44
D.3.4 EPA Site Remediation.....	44
E. LEGISLATIVE & REGULATORY SYSTEMS.....	45

E.1	Legislative System.....	45
E.2	Regulatory System .....	48
E.2.1	U.S. Nuclear Regulatory Commission.....	51
E.2.1.1	Uranium Recovery Regulation .....	53
E.2.1.2	HLW and Spent Fuel Regulation .....	54
E.2.1.3	LLW Regulation.....	55
E.2.1.4	Decommissioning Regulation .....	56
E.2.1.5	NRC's Integrated Materials Performance Evaluation Program .....	58
E.2.1.6	Advisory Committee on Nuclear Waste and Materials .....	59
E.2.2	U.S. Environmental Protection Agency .....	60
E.2.2.1	Waste Isolation Pilot Plant Oversight.....	60
E.2.2.2	EPA HLW and Spent Fuel Disposal Standards .....	61
E.2.2.3	Mixed Waste Regulation .....	62
E.2.2.4	Uranium Mining and Milling Air Emission Standards .....	62
E.2.2.5	Other EPA Radiation-Related Authorities .....	64
E.2.3	U.S. Department of Energy .....	64
E.2.4	Defense Nuclear Facilities Safety Board.....	67
E.2.5	Nuclear Waste Technical Review Board.....	67
E.2.6	National Council on Radiation Protection and Measurement.....	67
E.2.7	Regulatory Authorities of States.....	68
E.2.7.1	EPA Authorized States .....	68
E.2.7.2	NRC Agreement States .....	69
F.	GENERAL SAFETY PROVISIONS .....	71
F.1	Responsibilities of the License Holder (Article 21).....	71
F.1.1	Safety Responsibility of NRC and Agreement State License Holders .....	71
F.1.2	Integrated Safety Management at DOE .....	72
F.2	Human and Financial Resources (Article 22).....	73
F.2.1	Personnel Qualifications for NRC Licensees .....	74
F.2.2	DOE Qualification Requirements .....	74
F.2.3	Financial Surety.....	75
F.2.3.1	Commercial LLW Management Facilities.....	75
F.2.3.2	Spent Fuel and HLW Management Facilities.....	76
F.2.3.3	Uranium Recovery Waste Management Facilities .....	77
F.2.3.4	Complex Material Sites Decommissioning.....	78
F.3	Quality Assurance (Article 23).....	79
F.3.1	NRC Quality Assurance.....	80
F.3.2	DOE Quality Assurance.....	80
F.4	Operational Radiation Protection (Article 24).....	81
F.4.1	U.S. Environmental Protection Agency .....	81
F.4.2	NRC General Radiological Protection Limits.....	82
F.4.2.1	Occupational Dose Limits .....	82
F.4.2.2	Public Dose Limits.....	83
F.4.2.3	Radiological Criteria for License Termination (Decommissioning) .....	85
F.4.2.4	LLW Disposal Sites .....	85
F.4.2.5	Uranium Mill Tailings Disposal Sites .....	85
F.4.3	DOE Radiation Protection Regulations .....	86
F.4.4	Other Radiation Protection Regulations .....	88
F.5	Emergency Preparedness (Article 25) .....	88
F.5.1	Emergency Preparedness within NRC.....	88
F.5.1.1	Nuclear Facility Response Plans .....	88
F.5.1.2	NRC Response to an Emergency .....	89
F.5.1.3	NRC Emergency Response Exercises .....	90
F.5.1.4	Incident Investigation and Event Reporting .....	90
F.5.1.5	Emergency Preparedness at Radioactive Materials Facilities .....	91
F.5.2	Emergency Preparedness and Management within DOE.....	92
F.6	Decommissioning Practices (Article 26).....	93
F.6.1	NRC Decommissioning Approach.....	93
F.6.1.1	Nuclear Reactor Facilities .....	94

F.6.1.2	Materials Facilities and Activities .....	95
F.6.2	DOE Decommissioning Approach.....	96
F.7	General Safety Requirements (Articles 4 and 11).....	98
F.7.1	Criticality Control and Removal of Residual Heat .....	98
F.7.1.1	Criticality Control .....	98
F.7.1.2	Removal of Residual Heat .....	99
F.7.2	Waste Minimization .....	99
F.7.3	Interdependencies Among the Different Steps in Spent Fuel and Radioactive Waste Management Processes .....	101
F.7.4	National Laws/Regulations Providing Protection and Taking Into Account International Criteria and Standards .....	101
F.7.5	Biological, Chemical and Other Hazards.....	102
F.7.6	Avoidance of Undue Burden/Impacts on Future Generations.....	103
F.8	Existing Facilities (Articles 5 and 12).....	103
F.9	Siting Proposed Facilities (Articles 6 and 13).....	104
F.9.1	Environmental Assessment (NEPA Process).....	104
F.9.2	Site Selection.....	105
F.9.3	Public and Stakeholder Involvement .....	105
F.10	Design and Construction of Facilities (Articles 7 and 14) .....	107
F.11	Assessment of Safety of Facilities (Articles 8 and 15).....	108
F.12	Operation of Facilities (Articles 9 and 16) .....	108
F.12.1	NRC Inspection of Commercial Licensed Facilities and Activities .....	110
F.12.2	NRC Enforcement and Civil Penalties.....	110
F.12.3	Operation of DOE Facilities .....	112
G.	SAFETY OF SPENT FUEL MANAGEMENT .....	115
G.1	General Safety Requirements (Article 4).....	115
G.1.1	Interdependencies between Different Steps in the Spent Fuel Management Process .....	116
G.1.2	Avoidance of Undue Burden/Impacts on Future Generations.....	117
G.2	Existing Facilities (Article 5).....	117
G.3	Siting Proposed Facilities (Article 6).....	117
G.4	Design and Construction of Spent Fuel Management Facilities (Article 7).....	119
G.5	Assessment of Safety of Facilities (Article 8) .....	119
G.6	Operation of Facilities (Article 9) .....	120
G.7	Disposal of Spent Fuel (Article 10).....	121
H.	SAFETY OF RADIOACTIVE WASTE MANAGEMENT .....	123
H.1	Existing Commercial LLW Management Facilities and Past Practices (Article 12) .....	124
H.1.1	Currently-Licensed LLW Facilities .....	124
H.1.2	Past Practices and Formerly Licensed Facilities.....	126
H.1.3	Management Strategies for Low Activity Waste Sites.....	126
H.1.4	Controlling Disposition of Solid Materials .....	128
H.1.4.1	Surface Contaminated Radioactive Material Release.....	129
H.1.4.2	Volumetrically Contaminated Radioactive Material Release .....	129
H.2	DOE Waste Management Facilities .....	130
H.2.1	Past Practices (Article 12) .....	130
H.2.2	Siting Proposed Facilities (Article 13).....	131
H.2.3	Design and Construction (Article 14).....	131
H.2.4	Assessment of Safety of Facilities (Article 15) .....	131
H.2.5	Facilities Operation .....	135
H.2.6	Institutional Measures after Closure .....	135
H.3	Uranium Recovery Wastes .....	137
H.3.1	General Safety Requirements (Article 11).....	137
H.3.2	Existing Facilities/Past Practices (Article 12) .....	138
H.3.3	Uranium Recovery Radioactive Waste Management Facilities: Siting, Design and Construction (Articles 13 and 14).....	138
H.3.4	Uranium Recovery Radioactive Waste Management Facilities: Safety Assessment (Article 15) .....	139

H.3.5 Uranium Recovery Radioactive Waste Management Facilities: Institutional Measures after Closure (Article 17) .....	139
H.4 Monitoring Releases to the Environment .....	140
I. TRANSBOUNDARY MOVEMENT .....	143
I.1 Overview of U.S. Legal and Policy Framework Governing the Transboundary Movement of Radioactive Waste and Spent Fuel .....	143
I.1.1 Regulatory Issues and Considerations.....	143
I.1.2 Radioactive Waste.....	144
I.1.3 Incidental Radioactive Material.....	144
I.1.4 Spent Fuel .....	145
I.2 Regulatory Requirements for Export or Import of Radioactive Waste .....	145
I.2.1 Exports.....	145
I.2.2 Imports.....	146
I.3 Implementation Experience to Date .....	146
I.4 Security Programs .....	148
J. DISUSED SEALED SOURCES .....	149
J.1 General Safety for Sealed Sources .....	149
J.2 Reentry of Disused Sealed Sources from Abroad.....	150
J.3 Disposition of Sealed Sources.....	151
J.4 U.S. Radiological Threat Reduction Program .....	152
J.5 Illicit Trafficking and Nuclear Terrorism .....	152
K. PLANNED ACTIVITIES TO IMPROVE SAFETY .....	155
K.1 Spent Fuel and High-Level Waste Storage and Disposal .....	155
K.2 Commercial Low-Level Waste Disposal.....	155
K.3 Disused Sealed Sources and Greater-than-Class C LLW Disposal .....	156
K.4 Accelerated Return of Weapons-Usable Uranium from Other Countries to the United States and Russian Federation.....	156
K.5 Global Nuclear Energy Partnership .....	157
ANNEXES.....	159
Annex D-1 Spent Fuel Management Facilities .....	161
Annex D-2 Radioactive Waste Management Facilities.....	168
Annex D-3A Uranium Mill Tailings and Related Sites.....	176
Annex D-3B Expected New Uranium Recovery Facility Applications / Restarts / Expansions ..	183
Annex D-4 Pending and Ongoing DOE Decommissioning and Remediation Projects .....	185
Annex D-5 Formerly Utilized Sites Remedial Action Program Sites.....	186
Annex D-6 Decommissioning Of Complex Licensed Materials Sites .....	187
Annex D-7 NRC-Licensed Power and Demonstration Reactors Under Decommissioning .....	189
Annex E-1 NRC Guidance .....	190
Annex F-1 Qualification Requirements for NRC Staff and Procedures Related to Spent Fuel or Radioactive Waste Inspection.....	193
Annex F-2 Radiation Protection Guidance.....	194
Annex F-3 Emergency Event Categories.....	195
Annex F-4 NRC Participation in Emergency Exercises During 2005-2007 .....	195
Annex F-5 Requirements for Notifying NRC of Emergency and Non-Emergency Events .....	196
Annex F-6. Emergency Preparedness and Planning at Diverse Waste Management and Disposal Facilities .....	197
LIST OF ACRONYMS AND ABBREVIATIONS.....	200
ADDITIONAL REFERENCES.....	203



## List of Tables and Figures

Table A-1	Joint Convention Reporting Provisions .....	2
Table A-2	Key Sources of Information Available on the Internet .....	3
Table A-3	USA – Overview in Second Review Meeting Format .....	5
Table A-4	Challenges for the U.S. in the Safety of Spent Fuel and Radioactive Waste Management .....	9
Table B-1	U.S. Commercial Radioactive Waste Classification .....	14
Table B-2	DOE Radioactive Waste Classification for Disposal .....	15
Figure D-1	Typical Dry Cask Storage Systems .....	26
Figure D-2	Location of U.S. Spent Fuel and HLW Storage Installations .....	27
Table D-1	Spent Fuel Storage Facilities .....	28
Figure D-3	Conceptual View of Waste Package Emplacement for Disposal at Yucca Mountain .....	29
Table D-2	Radioactive Waste Storage and Treatment Facilities .....	30
Table D-3	Radioactive Waste Disposal Facilities .....	34
Table D-4	Low-Level Waste Received at Commercial Disposal Sites in 2007 .....	36
Table D-5	Summary of Decommissioning Activities in Progress .....	41
Table E-1	Key U.S. Laws Governing Radioactive Waste Management .....	46
Table E-2	Spent Fuel and Radioactive Waste Management Regulations .....	49
Table E-3	NRC Strategic Goals and Outcomes .....	51
Table F-1	Distribution of NRC FY 2009 Budget Request Full-Time Equivalents in Staff .....	73
Table F-2	NRC Staff for HLW, Spent Fuel, Decommissioning, LLW and Enforcement Activities .....	73
Figure F-1	Average Annual Values at Independent Spent Fuel Storage Facilities, 1982-2006 .....	84
Figure F-2	Estimated Off-Site Radiation Dose to the Public .....	87
Figure H-1	U.S. Low-Level Waste Compacts .....	125
Figure H-2	Conceptual Yucca Mountain Warning Monument .....	137
Table I-1	Completed Export/Import NRC Licensing Actions for January 2000 - August 2007 .....	147
Table I-2	Appendix P Licenses Issued January 2005 - August 2007 .....	147

This page intentionally left blank

## A. INTRODUCTION

This Third United States National Report updates the second National Report published in October 2005, under the terms of the *Joint Convention on the Safety of Spent Fuel Management and on the Safety of Radioactive Waste Management*<sup>1</sup> (Joint Convention). This report reflects developments in the United States through September 2008.

### A.1 Purpose and Structure of this Report

This report satisfies the requirements of the Joint Convention for reporting on the status of safety at spent fuel and radioactive waste management facilities within the United States of America. The United States ratified the Joint Convention on April 9, 2003. The Convention entered into force on July 10, 2003. The United States participated in the First Review Meeting held in Vienna, Austria, in November 2003 and the Second Review Meeting held in Vienna, Austria, in May 2006. The Joint Convention is an important part of a global effort to raise the level of nuclear safety at nuclear facilities in the aftermath of the 1986 accident at the Chernobyl nuclear power plant in the Ukraine, and other events. The Joint Convention provides incentives for nations<sup>2</sup> to bring their nuclear activities into compliance with internationally endorsed public health and safety standards or their equivalent. A copy of the Joint Convention is available electronically from the International Atomic Energy Agency (IAEA).<sup>3</sup>

The Joint Convention is structured similar to a companion Convention on Nuclear Safety (CNS), which entered into force for the United States on July 10, 1999. The Joint Convention provides a series of broad objectives for managing spent fuel and radioactive waste without prescribing specific or mandatory standards on contracting nations. The Joint Convention extends the review process in the CNS to spent fuel and radioactive waste management activities.<sup>4</sup> Each member nation having ratified the Joint Convention (Contracting Party) is obligated to prepare a National Report covering the scope of the Joint Convention and subject it to review by other Contracting Parties. The third review will culminate in a Meeting of the Contracting Parties in Vienna, Austria, in May 2009.

A.	Introduction
B.	Policies & Practices <ul style="list-style-type: none"><li>▪ Article 32, paragraph 1</li></ul>
C.	Scope of Application <ul style="list-style-type: none"><li>▪ Article 3.</li></ul>
D.	Inventories & Lists <ul style="list-style-type: none"><li>▪ Article 32, paragraph 2</li></ul>
E.	Legislative & Regulatory Systems <ul style="list-style-type: none"><li>▪ Article 18. Implementing Measures</li><li>▪ Article 19. Legislative &amp; Regulatory Framework</li><li>▪ Article 20. Regulatory Body</li></ul>
F.	General Safety Provisions <ul style="list-style-type: none"><li>▪ Article 21. Responsibility of License Holder</li><li>▪ Article 22. Human &amp; Financial Resources</li><li>▪ Article 23. Quality Assurance</li><li>▪ Article 24. Operational Radiation Protection</li><li>▪ Article 25. Emergency Preparedness</li><li>▪ Article 26. Decommissioning</li></ul>
G.	Safety of Spent Fuel Management <ul style="list-style-type: none"><li>▪ Article 4. General Safety Requirements</li><li>▪ Article 5. Existing Facilities</li><li>▪ Article 6. Siting of Proposed Facilities</li><li>▪ Article 7. Design &amp; Construction of Facilities</li><li>▪ Article 8. Facility Safety Assessment</li><li>▪ Article 9. Facility Operation</li><li>▪ Article 10. Spent Fuel Disposal</li></ul>
H.	Safety of Radioactive Waste Management <ul style="list-style-type: none"><li>▪ Article 11. General Safety Requirements</li><li>▪ Article 12. Existing Facilities &amp; Past Practices</li><li>▪ Article 13. Siting of Proposed Facilities</li><li>▪ Article 14. Design &amp; Construction of Facilities</li><li>▪ Article 15. Facility Safety Assessment</li><li>▪ Article 16. Facility Operation</li><li>▪ Article 17. Institutional Measures After Closure</li></ul>
I.	Transboundary Movement <ul style="list-style-type: none"><li>▪ Article 27.</li></ul>
J.	Disused Sealed Sources <ul style="list-style-type: none"><li>▪ Article 28.</li></ul>
K.	Planned Activities to Improve Safety
	Annexes

<sup>1</sup>International Atomic Energy Agency, *Joint Convention on the Safety of Spent Fuel Management and on the Safety of Radioactive Waste Management*, INFCIRC/516, December 24, 1997.

<sup>2</sup>Note the term "nation" is used here instead of "state" to avoid confusion with the "states" making up the United States.

<sup>3</sup>International Atomic Energy Agency, <http://www-ns.iaea.org/conventions/waste-jointconvention.htm>

<sup>4</sup>Disused sealed sources are also within the scope of the Joint Convention, as specified in the preamble of the Convention on Nuclear Safety.

This Department of Energy (DOE) report was prepared by a working group composed of staff from DOE and other agencies of the U.S. Government involved in international and domestic nuclear activities, including Department of State, U.S. Environmental Protection Agency (EPA), and Nuclear Regulatory Commission (NRC).

This report describes how the United States meets the objectives described in Article 1 of the Joint Convention:

1. *Achieve and maintain a high-level of safety worldwide in spent fuel and radioactive waste management through the enhancement of national measures and international cooperation, including where appropriate, safety-related technical cooperation;*
2. *Ensure there are effective defenses against potential hazards so individuals, society, and the environment are protected from the harmful effects of ionizing radiation, now and in the future to assure needs and aspirations of the present generation are met without compromising the ability of future generations to meet their needs and aspirations; and*
3. *Prevent accidents with radiological consequences, and mitigate such consequences should they occur during any stage of spent fuel or radioactive waste management.*

The report format and content follow revised guidelines, agreed to at the Second Review Meeting of Contracting Parties to the Joint Convention in May 2005, and published in July 2006.<sup>5</sup> Chapters and annexes (or appendices) in this report have the same titles as in these guidelines, facilitating review by other Contracting Parties. Table A-1 provides a cross-reference between the chapters in this report and the specific reporting provisions in the Joint Convention.

Table A-1 Joint Convention Reporting Provisions	
National Report Section	Joint Convention Section
A. Introduction	
B. Policies and Practices	Article 32, Paragraph 1
C. Scope of Application	Article 3
D. Inventories and Lists	Article 32, Paragraph 2
E. Legislative and Regulatory Systems	Article 18; Article 19; and Article 20
F. General Safety Provisions	Articles 21-26; Articles 4-9 ; Articles 11-16
G. Safety of Spent Fuel Management	Articles 4-10
H. Safety of Radioactive Waste Management	Articles 11-17
I. Transboundary Movement	Article 27
J. Disused Sealed Sources	Article 28
K. Planned Activities to Improve Safety	Multiple Articles
L. Annexes	Multiple Articles

<sup>5</sup>International Atomic Energy Agency, *Guidelines Regarding the Form and Structure of National Reports: Joint Convention on the Safety of Spent Fuel Management and on the Safety of Radioactive Waste Management, Vienna, Austria INFCIRC 604, Rev 1, July 19, 2006.*  
<http://www.iaea.org/Publications/Documents/Infcircs/2006/infcirc604r1.pdf>

Information in this report is derived from publicly available information sources. More detailed information can be found at the internet web sites listed in Table A-2. The internet references provided in this report were available to the public and accurate as of the publication date. These URLs may change over time or may no longer be active.

Table A-2 Key Sources of Information Available on the Internet	
<b>Code of Federal Regulations</b>	
Access to all regulations:	<a href="http://www.gpoaccess.gov/cfr/index.html">http://www.gpoaccess.gov/cfr/index.html</a>
Energy, Title 10: (Includes DOE and NRC regulations):	<a href="http://www.access.gpo.gov/cgi-bin/cfrassemble.cgi?title=200510">http://www.access.gpo.gov/cgi-bin/cfrassemble.cgi?title=200510</a>
Protection of the Environment, Title 40:	<a href="http://www.access.gpo.gov/cgi-bin/cfrassemble.cgi?title=200840">http://www.access.gpo.gov/cgi-bin/cfrassemble.cgi?title=200840</a>
<b>U.S. Department of Energy</b>	
Homepage:	<a href="http://www.energy.gov">http://www.energy.gov</a>
Office Health, Safety and Security:	<a href="http://hss.energy.gov">http://hss.energy.gov</a>
Office of Environmental Management:	<a href="http://www.em.doe.gov">http://www.em.doe.gov</a>
Office of Civilian Radioactive Waste Management:	<a href="http://www.ocrwm.doe.gov/">http://www.ocrwm.doe.gov/</a>
Office of Nuclear Energy/Global Nuclear Energy Partnership:	<a href="http://www.ne.doe.gov">http://www.ne.doe.gov</a>
Energy Information Administration:	<a href="http://www.eia.doe.gov/fuelnuclear.html">http://www.eia.doe.gov/fuelnuclear.html</a>
National Nuclear Security Administration:	<a href="http://www.nnsa.doe.gov">http://www.nnsa.doe.gov</a>
Orders and directives:	<a href="http://www.directives.doe.gov/">http://www.directives.doe.gov/</a>
Waste Isolation Pilot Plant:	<a href="http://www.wipp.ws/">http://www.wipp.ws/</a>
<b>U.S. Nuclear Regulatory Commission</b>	
Homepage:	<a href="http://www.nrc.gov/">http://www.nrc.gov/</a>
Regulations:	<a href="http://www.nrc.gov/reading-rm/doc-collections/cfr/">http://www.nrc.gov/reading-rm/doc-collections/cfr/</a>
Regulatory guides:	<a href="http://www.nrc.gov/reading-rm/doc-collections/reg-guides/">http://www.nrc.gov/reading-rm/doc-collections/reg-guides/</a>
Statutes and legislation:	<a href="http://www.nrc.gov/reading-rm/doc-collections/nuregs/staff/sr0980/">http://www.nrc.gov/reading-rm/doc-collections/nuregs/staff/sr0980/</a>
Advisory Committee on Nuclear Waste & Materials past reviews:	<a href="http://www.nrc.gov/reading-rm/doc-collections/acnw/">http://www.nrc.gov/reading-rm/doc-collections/acnw/</a>
Radioactive waste:	<a href="http://www.nrc.gov/waste.html">http://www.nrc.gov/waste.html</a>
Nuclear materials:	<a href="http://www.nrc.gov/materials.html">http://www.nrc.gov/materials.html</a>
Nuclear Decommissioning (Reactor and Materials):	<a href="http://www.nrc.gov/about-nrc/regulatory/decommissioning.html">http://www.nrc.gov/about-nrc/regulatory/decommissioning.html</a>
Sealed sources and Devices:	<a href="http://www.nrc.gov/materials/miau/sealed-source.html">http://www.nrc.gov/materials/miau/sealed-source.html</a>
Spent Fuel Storage:	<a href="http://www.nrc.gov/waste/spent-fuel-storage.html">http://www.nrc.gov/waste/spent-fuel-storage.html</a>
NARM Toolbox:	<a href="http://nrc-stp.ornl.gov/narmtoolbox.html">http://nrc-stp.ornl.gov/narmtoolbox.html</a>
High-Level-Waste Disposal:	<a href="http://www.nrc.gov/waste/hlw-disposal.html">http://www.nrc.gov/waste/hlw-disposal.html</a>
<b>U.S. Environmental Protection Agency</b>	
Homepage:	<a href="http://www.epa.gov/">http://www.epa.gov/</a>
Regulations:	<a href="http://www.epa.gov/epahome/cfr40.htm">http://www.epa.gov/epahome/cfr40.htm</a>
Major environmental laws:	<a href="http://www.epa.gov/epahome/laws.htm">http://www.epa.gov/epahome/laws.htm</a>
Office of Air and Radiation:	<a href="http://www.epa.gov/oar">http://www.epa.gov/oar</a>
Office of Solid Waste:	<a href="http://www.epa.gov/osw/">http://www.epa.gov/osw/</a>
Radiation Program:	<a href="http://www.epa.gov/radiation/">http://www.epa.gov/radiation/</a>
Waste Isolation Pilot Plant Oversight:	<a href="http://www.epa.gov/radiation/wipp/index.html">http://www.epa.gov/radiation/wipp/index.html</a>
Yucca Mountain Standards:	<a href="http://www.epa.gov/radiation/yucca/index.html">http://www.epa.gov/radiation/yucca/index.html</a>
<b>Other</b>	
U.S. Department of State, Bureau of Nonproliferation:	<a href="http://www.state.gov/tnp/">http://www.state.gov/tnp/</a>
U.S. Defense Nuclear Facilities Safety Board:	<a href="http://www.dnfsb.gov/">http://www.dnfsb.gov/</a>
National Academy of Sciences:	<a href="http://www4.nationalacademies.org/nas/nashome.nsf">http://www4.nationalacademies.org/nas/nashome.nsf</a>
National Council on Radiation Protection and Measurements:	<a href="http://www.ncrp.com/">http://www.ncrp.com/</a>
U.S. Nuclear Waste Technical Review Board (NWTRB):	<a href="http://www.nwtrb.gov/">http://www.nwtrb.gov/</a>

Table A-2 Key Sources of Information Available on the Internet
Conference of Radiation Control Directors, Inc.: <a href="http://www.crcpd.org/">http://www.crcpd.org/</a>
U.S. Customs and Border Protection: <a href="http://www.customs.ustreas.gov/">http://www.customs.ustreas.gov/</a>
Department of Homeland Security: <a href="http://www.dhs.gov">http://www.dhs.gov</a>
U.S Public Health Service: <a href="http://www.usphs.gov/">http://www.usphs.gov/</a>
U.S. Army Corps of Engineers Formerly Utilized Sites Remedial Action Program: <a href="http://hq.environmental.usace.army.mil/programs/fusrap/fusrap.html">http://hq.environmental.usace.army.mil/programs/fusrap/fusrap.html</a>
Interagency Steering Committee on Radiation Standards (ISCORS): <a href="http://www.iscors.org/">http://www.iscors.org/</a>

## A.2 Summary Results from the Previous Review

The *Guidelines Regarding the Form and Structure of a National Report* require National Reports to contain conclusions from the discussion of the Contracting Party's National Report at the previous Review Meeting. The discussions and conclusions from the Second Review Meeting, as well as the questions and comments from the other Contracting Parties, are reflected in this Third National Report.

The previous review noted that the U.S. experience with the Waste Isolation Pilot Plant (WIPP) repository for the disposal of defense-related transuranic (TRU) waste and the U.S. program of accepting U.S.-origin foreign research reactor spent fuel back to the United States constituted exemplary highlights of experience in implementing concrete actions to promote safety and security. The disused source recovery program was seen also as a concrete action to improve national and international safety. Other good practices included: early public and stakeholder involvement in the licensing process; using local meetings and internet access; integrating future use considerations in licensing decisions; and the strong commitment to active decommissioning and safe permanent disposal. The U.S. National Report was considered a good model for other Contracting Parties for structural elements to identify good practices and challenges. Challenges included the potential shortage of capacity for Low-Level Waste (LLW) disposal, no permanent solution for Greater-than-Class C (GTCC) LLW, lack of national standards for clearance, and regulatory uncertainties associated with prolonged compliance periods for geologic disposal.

The United States made the Global Nuclear Energy Partnership (GNEP) initiative a central theme in its participation in the Second Review Meeting of the Contracting Parties. This emphasis was well received by the participating delegations.

The Contracting Parties agreed, for the Third Review Meeting, National Reports should be more focused on practical implementing activities, and on issues raised during the Second Review Meeting. The National Reports should place greater emphasis on lessons learned and feedback experience from the implementation of concrete actions. These recommendations were in keeping with the concept of benefit from an increasing technical and practical content, and further enhanced openness and frankness.

Finally, the U.S. continues to believe the IAEA Safety Standards can provide valuable guidance as to the requirements, standards, and practices that a country can use to establish or enhance its national programs. As such, these standards represent a useful source of guidance, among others, to which a Contracting Party could refer, on a

voluntary basis, in preparing its National Report.<sup>6</sup> These standards, however, do not prescribe the only approach to establishing strong national programs and are not binding on any country, except to the extent an individual country, acting in accordance with its national processes, incorporates all or part of them into its national law or regulations. These standards should not be treated as supranational requirements or standards that a country must follow or justify why it does not follow.

### A.3 What's New Since Last Report

This updated report reflects many changes due to comments received on the previous version, and new developments since it was published.

To provide continuity from the Second Review Meeting, the rapporteur's matrix has been revised with citations to explanatory sections of the National Report. Table A-3 presents the revised overview of the U.S. program.

The U.S. program was complimented for its successes such as the U.S. policy for permanent geologic disposal, the orphan source recovery program, early involvement of affected parties and stakeholders to increase public understanding and confidence, the decommissioning process improvements and an outstanding 25-year safety record for transport of nuclear materials.

However, a number of challenges were identified; these are summarized with their respective progress in the 3 years since the Second Review Meeting in Table A-4.

Type of Liability	Long-term Management Policy	Funding of Liabilities	Current Practice / Facilities	Future Facilities
<b>Spent fuel</b>	Disposal in geological repository.  Acceptance of foreign research and test reactor fuel.  Development of future recycling (reprocessing) capability. (GNEP)  See B.3.3, E.2.1.2, F.7.6, G.1.1, G.5, G.7, K.1, K.5	Nuclear Waste Fund fee on electricity generated and sold is collected by utilities; subject to annual Congressional appropriation.  See F.2.3, F.2.3.2	On-site and away from reactors wet & dry interim storage (private & government property).  See B.3.1 B.3.3, D.1.1, D.2.1.1, D.2.2.1, F.2.3.2, F.12, Section G, Annex D-1.	Yucca Mountain Geological Repository  DOE Report to Congress by 2010 on need for a second repository.  See D.1.2, D.2.1, F.2.3.2 and Section G, G.3, G.5 and G.7, K.1, K5.
<b>Nuclear fuel cycle wastes (all LLW included in Non-Nuclear fuel cycle wastes for brevity)</b>	<b>HLW:</b> Disposal in geological repository.  <b>U&amp;Th tailings:</b> Near surface disposal.  See D.2.2.3, E.2.1.1, E.2.2.4, H.2.4, H.2.6,	<b>All:</b> Producer pays.  <b>U&amp;Th disposal sites:</b> Long Term Surveillance Fund  Financial assurance required by license.	<b>HLW:</b> Interim storage pending geologic disposal.  <b>U&amp;Th milling sites:</b> surface disposal locally.  See B.3.4, B.4.3, B.4.4,	<b>HLW:</b> Yucca Mountain Geological Repository.  <b>U&amp;Th milling sites:</b> higher prices of uranium may lead to over 20 license

<sup>6</sup> Summary Report. Second Review Meeting of the Contracting Parties 15 to 24 May 2006, Vienna, Austria. JC/RM.2/03/Rev.1. May 23, 2006.

<sup>7</sup> Refer to LIST OF ACCRONYMS AND ABBREVIATIONS at the end of the report.

Table A-3 USA – Overview<sup>7</sup> in Second Review Meeting Format

Type of Liability	Long-term Management Policy	Funding of Liabilities	Current Practice / Facilities	Future Facilities
	H.3.5	See F.2.3.3, H.3.5	D.2.1.1, D.2.2.3, F.4.2.5, H.3.2, H.3.3, Annexes D-2, D-3A, D-3B	applications in 3 years.  See B.4.4, D.2.1.1
<b>Non-Nuclear fuel cycle wastes</b>	<p><b>Defense HLW and TRU waste:</b> Disposal in geological repository.</p> <p><b>LLW:</b> near surface disposal.</p> <p>See D.2.1.3, D.2.2.2, D.2.2.3.1, D.2.2.3.2, D.3.2, E.2.1.3, E.2.2.1, F.2.3.3, H.1.2, H.2.6, H.3.2, H.3.5</p>	<p><b>All:</b> Producer pays</p> <p><b>Defense HLW and TRU waste:</b> public funds.</p> <p><b>LLW:</b> licensees required to demonstrate financial qualifications.</p> <p>See D.2.1.1, F.2.3.1</p>	<p><b>Defense HLW:</b> interim storage pending geologic disposal.</p> <p><b>Defense TRU waste:</b> disposal at WIPP.</p> <p><b>LLW:</b> 3 commercial sites.</p> <p>Interim storage of GTCC LLW.</p> <p>See B.4.2, B.4.5, D.2.1.2, D.2.1.3, D.2.2.1, D.2.2.3, E.2.1.3, F.4.2.4, H.1, Annex D-5</p>	<p><b>Defense HLW:</b> Yucca Mountain Geological Repository.</p> <p><b>LLW:</b> 1 pending site for Class A, B and C LLW disposal.</p> <p>GTCC LLW disposal alternatives study in progress.</p> <p>See K.2-K.3</p>
<b>Decommissioning liabilities</b>	<p><b>Nuclear power plants (NPPs):</b> D&amp;D to be completed within 60 years.</p> <p><b>Defense, milling and other sites:</b> Based on risk.</p> <p>See D.3, E.2.1.1, E.2.1.4, F.6, H.1.3, H.2.6</p>	<p><b>NPPs:</b> D&amp;D fund required by law</p> <p><b>Non-legacy Sites:</b> Producer pays</p> <p><b>Defense sites:</b> Public funds for defense liabilities</p> <p>See F.2.3.4, H.3.5</p>	<p>Large number of facilities undergoing decommissioning/ remediation.</p> <p>See B.5, D.3, E.2.1.4, F.4.2.3, F.6, F.7.2, H.1.4, Annexes D-4, D-6, D-7</p>	<p>Large number of facilities planned for decommissioning/ remediation.</p> <p>Annexes D-6 &amp; D-7.</p>
<b>Disused Sealed Sources</b>	<p>Disposal or recycle.</p> <p>See Section J</p>	<p>Licensee or governmental responsibility.</p> <p>See Section J</p>	<p>Disposal at government &amp; commercial disposal sites.</p> <p>Interim storage of GTCC sources.</p> <p>Off-site Source Recovery Project.</p> <p>See Section J, K.3</p>	<p>GTCC LLW disposal facility</p> <p>See B.2.3.2, D.2.1.2, K.3</p>

Progress made by the U.S. since the Second Review Meeting includes:

- DOE submitted a license application to the NRC on June 3, 2008, for authorization to begin construction of a proposed repository at Yucca Mountain, Nevada. On September 8, 2008, NRC formally docketed the Yucca Mountain license application. The decision to docket the application was based on the NRC staff's conclusion that the application was sufficiently complete for it to begin its full technical review. NRC is evaluating the application and, by law, is



required to issue a final decision approving or disapproving issuing a construction authorization not later than three years after submission of a complete license application. NRC may extend this deadline by not more than 12 months if certain reporting requirements are met. See Sections D.1.2, D.2.1, F.2.3.2 and G for additional details.

- EPA issued the final rule for Public Health and Environmental Radiation Protection Standards for Yucca Mountain in 40 CFR Part 197, on June 13, 2001. That rule established, among other things, a 0.15 mSv/a (15 mrem/yr) standard for the 10,000 year period after closure of the repository. In July 2004, a Federal Court vacated the 10,000-year compliance period as inconsistent with the recommendations of the National Academy of Sciences (NAS) to assess compliance at the time of peak risk (See Section E.2.1.2). In September 2008, EPA issued an amended rule that maintains the 0.15 mSv/a (15 mrem/yr) standard for the first 10,000 years and establishes a 1 mSv/a (100 mrem/yr) standard for the period after the initial 10,000 years out to one million years.
- GNEP announced by DOE just prior to the Second Review Meeting of the Contracting Parties in 2006, continues to be a key U.S. initiative promoting safety and energy security, both domestically and internationally. As October 1, 2008, 25 nations have signed the GNEP Statement of Principles. See Sections B.3.4 and K.5 for additional information.
- The U.S. has increased its investment in global initiatives to combat nuclear terrorism. Sections I.4, J.4 and J.5 describe the Megaports Initiative, U.S. Radiological Threat Reduction program, and measures taken against illicit trafficking of nuclear materials and nuclear terrorism. The U.S. continues to support eliminating the use of highly-enriched uranium (HEU) in civil applications and securing, returning, or recovering the nuclear material is an important part of the Global Threat Reduction Initiative (GTRI). This action will help to secure radiological sites around the world, providing assistance for return of Russian-origin HEU or spent fuel, accepting the return of US-origin HEU or spent fuel from around the world, and down-blending surplus U.S. HEU into low-enriched uranium for use in civilian nuclear reactors. See Section K.4 for additional information on GTRI.
- Industry and regulators in the U.S. are increasing efforts in new and expanded nuclear fuel cycle activities. Although nuclear power plant regulation is outside the scope of this report, from 2007 to 2010 NRC is expected to receive a total of 23 new reactor license applications, consisting of 34 new units. These numbers are as of August 5, 2008.<sup>8</sup> New enrichment plants are also planned or under construction. There is a large interest in reopening uranium mines and developing new, restarting, or expanding existing uranium recovery facilities resulting from increase in uranium prices. NRC received its first new license applications for uranium recovery facilities in 2007. These were the first such requests in nearly 20 years. See Sections B.4.4 and B.4.5 for additional information.

---

<sup>8</sup> See <http://www.nrc.gov/reactors/new-licensing/new-licensing-files/expected-new-rx-applications.pdf>

- DOE received approval from EPA and a modified hazardous waste facility permit from the State of New Mexico to dispose of remote-handled (RH) TRU waste at the Waste Isolation Pilot Plant (WIPP). WIPP began accepting defense-generated, remote-handled TRU waste at WIPP on January 22, 2007. DOE has now increased RH TRU shipments to WIPP to as many as four shipments per week. See Section D.2.2.1 for additional information.
- DOE began preparing an Environmental Impact Statement (EIS) in 2007, to dispose of GTCC LLW and other DOE GTCC-like waste. The Low-Level Radioactive Waste Policy Amendments Act of 1985 (LLRWPA) directs that GTCC waste resulting from NRC licensed activities must be disposed of in an NRC licensed facility. This EIS considers alternatives for disposal in a geologic repository, intermediate depth boreholes, and enhanced near-surface facilities. See Section D.2.1.2 for additional information.
- The Atlantic Compact restricted access in July 2008 to the commercial LLW disposal site in Barnwell, South Carolina by all waste generators except those generators within three states composing the Atlantic Compact (South Carolina, Connecticut, and New Jersey). See Sections D.2.2.2 and K.2 for additional information.
- NRC is examining whether the disposal of large quantities of depleted uranium (DU) from enrichment plants warrants amending current regulations. DU is either categorized as a “resource,” for variety of applications and uses, in which case it is a source (nuclear) material, or may be designated as a “waste” requiring disposal. See Section B.4.5 for additional details.
- NRC published regulations on November 8, 2006 (Federal Register, 71 FR 65685) to implement the National Source Tracking System (NSTS). The purpose is to enhance control of radioactive materials considered to be of the greatest concern from a safety and security standpoint. The NSTS involves other Federal and state agencies and international partners. All Category 1 and 2 (consistent with IAEA definition) sealed sources to which the regulations apply will be reported through the NSTS by January 2009. See Section J.2 for additional information.

<b>Table A-4 Challenges for the U.S. in the Safety of Spent Fuel and Radioactive Waste Management</b>	
<b>Challenges</b>	<b>Current Status</b>
The potential shortage of LLW disposal capacity requiring additional storage solutions.	A strategic assessment of the commercial LLW program resulted in a range of activities to improve the LLW regulatory framework, such as better guidance on extended storage, reconsideration of waste classification to include depleted uranium, and other alternatives for disposal. Furthermore, a license for LLW disposal (excluding GTCC LLW) is under review by the State of Texas.
The lack of a repository for Greater-than-Class-C LLW.	Preparation began in 2007 on an Environmental Impact Statement (EIS) to dispose of GTCC LLW and other DOE GTCC-like waste.
The lack of a national clearance standard and the impact to public confidence.	Although a national clearance standard would have regulatory benefits, it has been deferred because of higher priority tasks and limited resources. The current case-by-case decision process is fully protective of human health and safety.
The sustained funding required to build the repository will be well above current and historic levels.	Legislation has been proposed to facilitate the necessary funding for the construction and operation of the repository.

This page intentionally left blank

## B. POLICIES AND PRACTICES

This section summarizes the U.S. national policy for spent fuel and radioactive waste management, and related nuclear activities. The U.S. national policy is to provide safe disposal of spent fuel and radioactive waste to ensure long-term containment and isolation from the environment. The section also describes:

- The different roles and responsibilities of Federal government agencies and commercial or private sector entities in the use of nuclear energy in the United States;
- The classification of spent fuel and types of radioactive waste; and
- The practices for spent fuel and radioactive waste management, including background information.

### B.1 U.S. National Policy on Nuclear Activities

The Atomic Energy Act of 1946 created the Atomic Energy Commission (AEC) to encourage the use of nuclear power and regulate its safety. This made development of commercial nuclear power in the private sector possible. The U.S. Government has actively promoted the development of commercial nuclear power and ensured its safe use.

The Energy Reorganization Act of 1974 redistributed the functions performed by the AEC to two new agencies. The reorganization assigned promotional and regulatory duties of AEC for commercial activities to different agencies. The Act created the Nuclear Regulatory Commission (NRC) as an independent agency to regulate private sector and non-military governmental nuclear power, and Energy Research and Development Administration (ERDA) to promote energy and nuclear power development. NRC is an independent authority regulating the possession and use of nuclear materials as well as the siting, construction, and operation of nuclear facilities. ERDA was established to ensure development of all energy sources, increase efficiency and reliability of energy resource use. It was also responsible for AEC military and production activities, and general basic research activities.

NRC began regulatory operations on January 19, 1975. It performs its mission by issuing regulations, licensing commercial nuclear reactor construction and operation, licensing the possession of and use of nuclear materials and wastes, safeguarding nuclear materials and facilities from theft and radiological sabotage, inspecting nuclear facilities, and enforcing regulations. NRC regulates commercial nuclear fuel cycle materials and facilities, commercial sealed sources, including disused sealed sources. NRC is also responsible for licensing commercial nuclear waste management facilities, independent spent fuel management facilities, and the proposed Yucca Mountain

A.	Introduction
B.	<b>Policies &amp; Practices</b> <ul style="list-style-type: none"><li>▪ Article 32, paragraph 1</li></ul>
C.	Scope of Application <ul style="list-style-type: none"><li>▪ Article 3.</li></ul>
D.	Inventories & Lists <ul style="list-style-type: none"><li>▪ Article 32, paragraph 2</li></ul>
E.	Legislative & Regulatory Systems <ul style="list-style-type: none"><li>▪ Article 18. Implementing Measures</li><li>▪ Article 19. Legislative &amp; Regulatory Framework</li><li>▪ Article 20. Regulatory Body</li></ul>
F.	General Safety Provisions <ul style="list-style-type: none"><li>▪ Article 21. Responsibility of License Holder</li><li>▪ Article 22. Human &amp; Financial Resources</li><li>▪ Article 23. Quality Assurance</li><li>▪ Article 24. Operational Radiation Protection</li><li>▪ Article 25. Emergency Preparedness</li><li>▪ Article 26. Decommissioning</li></ul>
G.	Safety of Spent Fuel Management <ul style="list-style-type: none"><li>▪ Article 4. General Safety Requirements</li><li>▪ Article 5. Existing Facilities</li><li>▪ Article 6. Siting of Proposed Facilities</li><li>▪ Article 7. Design &amp; Construction of Facilities</li><li>▪ Article 8. Facility Safety Assessment</li><li>▪ Article 9. Facility Operation</li><li>▪ Article 10. Spent Fuel Disposal</li></ul>
H.	Safety of Radioactive Waste Management <ul style="list-style-type: none"><li>▪ Article 11. General Safety Requirements</li><li>▪ Article 12. Existing Facilities &amp; Past Practices</li><li>▪ Article 13. Siting of Proposed Facilities</li><li>▪ Article 14. Design &amp; Construction of Facilities</li><li>▪ Article 15. Facility Safety Assessment</li><li>▪ Article 16. Facility Operation</li><li>▪ Article 17. Institutional Measures After Closure</li></ul>
I.	Transboundary Movement <ul style="list-style-type: none"><li>▪ Article 27.</li></ul>
J.	Disused Sealed Sources <ul style="list-style-type: none"><li>▪ Article 28.</li></ul>
K.	Planned Activities to Improve Safety
	Annexes

repository for disposal of high-level waste (HLW) and spent fuel. NRC also oversees certain state programs where NRC has relinquished limited regulatory authority to the individual states.

The Department of Energy Organization Act (1977) brought a number of the Federal government's agencies and programs, including ERDA, into a single agency. DOE was given responsibility for, among other matters, nuclear energy, nuclear weapons programs, and new nuclear-related activities for environmental remediation of contaminated sites and surplus facilities. DOE has regulatory authority over its facilities and nuclear activities, and those operated or conducted on its behalf, except where NRC is specifically authorized by statute to regulate DOE activities, like the proposed Yucca Mountain repository, that must be licensed by NRC.

Presidential Directive created the Environmental Protection Agency (EPA) in 1970 to address a growing public demand in the United States for cleaner water, air, and land. EPA has responsibility to repair the damage already done to the environment and establish new criteria for a cleaner environment. EPA establishes generally applicable environmental standards to protect the environment from hazardous materials and certain radioactive materials. This and subsequent legislation gave EPA authority to establish standards for remediating active and inactive uranium mill tailing sites, environmental standards for the uranium fuel cycle, and environmental radiation protection standards for management and disposal of spent fuel, high-level waste (HLW), and transuranic (TRU) waste. EPA promulgates standards for and certifies compliance at the Waste Isolation Power Plant (WIPP) repository for disposal of defense-related TRU waste. EPA standards, under the Clean Air Act, limit airborne emissions of radionuclides from DOE sites managing defense-related spent fuel and radioactive waste. The regulatory roles of the U.S. agencies for nuclear activities are described in detail in Section E.

## **B.2 Government and Commercial Entities**

### **B.2.1 Government Sector**

The Department of Energy (DOE) is responsible for and performs most of the spent fuel and radioactive waste management activities for Government-owned and generated waste and materials, mostly located on Government-owned sites. These activities include managing spent fuel remaining from decades of defense reactor operations, which ceased in the early 1990s. DOE has safely stored the remaining defense spent fuel and spent fuel generated in a number of research and test reactors since then. DOE also provides safe storage for the core of the decommissioned Fort St. Vrain gas-cooled reactor and the core of the Three-Mile-Island Unit 2 reactor damaged in a 1979 accident.

DOE has a national system for managing government spent fuel and radioactive waste. This includes numerous storage facilities and processing facilities (treatment and conditioning). Operating disposal facilities for low-level waste (LLW) and WIPP for TRU waste are further described in Section D.2.2 of this report. DOE is pursuing licensing and construction of a geologic repository for spent fuel and HLW at Yucca Mountain, Nevada. The proposed geologic repository will provide permanent disposal of spent fuel and HLW from commercial and government facilities. More information on the proposed geologic repository is in Section D.1.2. Other waste management treatment and

disposal systems support cleanup and closure of facilities no longer serving a DOE mission. More information is in Section D on spent fuel and radioactive waste facilities in the government sector.

Decommissioning activities generate radioactive waste in both the commercial and government sectors. Decommissioning activities are described in Section D.3.

The United States also continues activities to remove and/or secure high-risk nuclear and radiological materials around the world. Part of this initiative is continuing the program of accepting U.S.-origin foreign research reactor spent fuel back into the United States for safe-keeping. More information is in Sections I.4, J.4, and K.5.

## **B.2.2 Commercial Sector**

Owners and operators of nuclear power plants and other types of facilities generating radioactive waste manage the spent fuel and radioactive waste generated by their facilities prior to disposal. U.S. Federal or state governments, however, will ultimately administer waste disposal sites. Government custody may occur at different stages of the waste management scheme depending on the type of radioactive waste and generating activity. The interdependencies between the steps in spent fuel and radioactive waste management are addressed in Section F.7.3. Section D provides additional information on commercial spent fuel and radioactive waste management.

## **B.2.3 Classification of Spent Fuel and Radioactive Waste**

Regulations addressing various aspects of the generation and control of radioactive wastes and other nuclear activities are in the United States Code of Federal Regulations (CFR), specifically Title 10 (Energy) and Title 40 (Protection of the Environment) of the CFR. They address the storage, treatment, possession, use and disposal of spent fuel and radioactive waste. Section E discusses various regulations. The U.S. classification system has two separate subsystems. One classification subsystem applies to commercial waste and is defined in NRC regulations. The other classification subsystem applies to DOE spent fuel and waste. The two systems are used for different purposes and different situations so conflicts do not occur.

### **B.2.3.1 Spent Fuel**

Spent fuel in the United States is fuel withdrawn from a nuclear reactor following irradiation, the constituent elements of which have not been chemically separated by reprocessing.

### **B.2.3.2 Radioactive Waste**

Radioactive wastes in the United States have many designations depending on their hazards and the circumstances and processes creating them. NRC regulates most, but not all, sources of radioactivity, including LLW and HLW disposal, and residues from the milling of uranium and thorium.<sup>9</sup> Uranium mill tailings, the final byproduct of uranium ore extraction, are considered radioactive wastes. Radioactivity can range from just above background to very high levels, such as parts from inside the reactor vessel in a nuclear

---

<sup>9</sup>Referred to in Section 11e.(2) of the Atomic Energy Act as byproduct material.

power plant. The day-to-day rubbish generated in medical laboratories and hospitals, contaminated by medical radioisotopes, is also designated radioactive waste.

NRC regulations in 10 CFR Part 61 classify LLW in the commercial sector as Class A, Class B, Class C and Greater-than-Class C (GTCC) LLW.<sup>10</sup> This classification is based on potential LLW hazards, and disposal and waste form requirements. Class A LLW contains lower concentrations of radioactive material than Class B LLW, which has lower concentrations than Class C LLW. Table B-1 provides the commercial waste classes.

Waste Class	Description
HLW	The highly radioactive material resulting from reprocessing of spent nuclear fuel, including liquid waste produced directly in reprocessing and any solid material derived from such liquid waste containing fission products in sufficient concentrations and other highly radioactive material NRC, consistent with existing law, determines by rule requires permanent isolation. <sup>11</sup>
Class A LLW	The physical form and characteristics must meet the minimum requirements at 10 CFR 61.56.
Class B LLW	Waste that must meet more rigorous requirements on waste form than class A waste to ensure stability.
Class C LLW	Waste that not only must meet more rigorous requirements on waste form than class B waste to ensure stability but also requires additional measures at the disposal facility to protect against inadvertent intrusion.
GTCC LLW	LLW not generally acceptable for near-surface disposal.
11e.(2) Byproduct Material	Tailings or wastes produced by the extraction or concentration of uranium or thorium from any ore processed primarily for its source material content, including discrete surface wastes resulting from uranium solution extraction processes. Underground ore bodies depleted by such solution extraction operations do not constitute "byproduct material" within this definition. <sup>12</sup>

Radioactive waste from DOE nuclear operations is classified as HLW, TRU waste, or LLW. Waste may also contain hazardous waste constituents. Waste with both radioactive and hazardous constituents in the United States is called "mixed" waste (mixed LLW or mixed TRU waste). TRU waste generally consists of protective clothing, tools, glassware, equipment, soils, and sludge contaminated with manmade radioisotopes beyond or "heavier" than uranium on the periodic table of the elements. These elements include plutonium, neptunium, americium, curium, and californium. TRU waste is produced during nuclear fuel research and development; and during nuclear weapons research, production, and cleanup. DOE manages spent fuel as a nuclear material and not as a waste. Generally, the source of HLW is reprocessed spent fuel. Table B-2 provides DOE waste classes. DOE uses the TRU waste class for long-lived, alpha emitting waste (see Table B-2 for complete definition).

<sup>10</sup> This classification system is based on protection of the inadvertent intruder.

<sup>11</sup> From the Nuclear Waste Policy Act, as amended.

<sup>12</sup> Title 10 CFR Part 40, *Domestic Licensing of Source Material (Section 40.4)*



Table B-2 DOE Radioactive Waste Classification for Disposal	
Waste Class	Description
HLW	High-level waste is the highly radioactive waste material resulting from the reprocessing of spent nuclear fuel, including liquid waste produced directly in reprocessing and any solid material derived from such liquid waste containing fission products in sufficient concentrations; and other highly radioactive material determined, consistent with existing law, to require permanent isolation. <sup>13</sup>
TRU	Radioactive waste containing more than 3,700 becquerels (100 nanocuries) of alpha-emitting transuranic isotopes per gram of waste, with half-lives greater than 20-years, except for: (1) HLW, (2) waste the Secretary of Energy has determined, with the concurrence of the Administrator of EPA, does not need the degree of isolation required by the 40 CFR Part 191 disposal regulations; or (3) waste NRC has approved for disposal on a case-by-case basis in accordance with 10 CFR Part 61. <sup>14</sup>
LLW	Radioactive waste <u>not</u> HLW, spent fuel, TRU waste, byproduct material (as defined in section 11(e).2 of the Atomic Energy Act of 1954, as amended), or naturally occurring radioactive material. <sup>15</sup>
11e.(2) Byproduct Material	The tailings or wastes produced by the extraction or concentration of uranium or thorium from any ore processed primarily for its source material content. <sup>16</sup>

### B.2.3.3 Other Regulated Radioactive Materials

NRC regulates other radioactive materials, but does not designate them as waste in the context of the Atomic Energy Act (AEA) of 1954, as amended. The definition of byproduct material was recently expanded by the Energy Policy Act of 2005 (EPA05) to include discrete sources of <sup>226</sup>Ra, other Naturally Occurring Radioactive Materials (NORM) of similar hazard, and Accelerator Produced Radioactive Material (ARM). EPA05 relates to “discrete” and not diffuse sources. The expanded definition includes material now defined as 11e.(3) and 11e.(4) byproduct material, which refers to the citation in the AEA.

EPA05 also allowed this newly defined material (not regulated as low-level radioactive waste) to be disposed of in either a licensed radioactive waste or a permitted non-radioactive waste disposal facility. NRC can relinquish its EPA05 authority to individual states<sup>17</sup> to regulate these radioactive materials.<sup>18</sup> Individual states usually regulate the radioactive materials not regulated by NRC.

The Office of Surface Mining of the U.S. Department of Interior and the individual states regulate uranium ore mining. If there are elevated levels of diffuse radium or other

<sup>13</sup> Nuclear Waste Policy Act of 1982 (NWPA), as amended; DOE Manual 435.1, *Radioactive Waste Management* ..

<sup>14</sup> Waste Isolation Pilot Plant Land Withdrawal Act of 1992 (WIPP LWA), as amended; DOE Manual 435.1, *Radioactive Waste Management*.

<sup>15</sup> DOE Manual 435.1, *Radioactive Waste Management* citing the Nuclear Waste Policy Act of 1982, as amended.

<sup>16</sup> DOE Manual 435.1, *Radioactive Waste Management* citing Atomic Energy Act of 1954, as amended.

<sup>17</sup> In this context, “states” within the United States of America are similar to provinces or departments indicating the next level of government below the Federal level.

<sup>18</sup> More information is available from NRC’s NARM Toolbox at <http://nrc-stp.ornl.gov/narmtoolbox.html>.

naturally occurring radioactive materials, then EPA and individual states have jurisdiction. Other extraction mining and refinement operations for metals, phosphates, etc. may concentrate naturally occurring radionuclides in these tailings materials. NRC specifically licenses some mineral extraction processes (not for nuclear content), because they incidentally result in the use, or concentration, of material above 0.05 percent by weight source material. Identified processors are required to obtain an NRC license.

### **B.3 Spent Fuel Management Practices**

This subsection provides information on spent fuel storage and disposal practices in the United States. Past reprocessing activities are also described.

#### **B.3.1 Spent Fuel Storage**

The United States produces spent fuel in commercial nuclear power plants, research reactors, and defense reactors. Currently 104 licensed nuclear power reactors provide about 20 percent of the electricity generated in this country. Information on U.S. nuclear power reactors is in NUREG-1650<sup>19</sup> Revision 2, *U.S. National Report for the Convention on Nuclear Safety*. All operating nuclear power reactors are storing spent fuel in NRC licensed on-site spent fuel pools (SFPs) and about half are also storing spent fuel in NRC-licensed, on-site independent spent fuel storage installations (ISFSIs). Most nuclear power plants that have been decommissioned or are undergoing decommissioning also have spent fuel stored on site pending disposal. Most permanently-shutdown commercial nuclear power reactors currently have or are planning to have their spent fuel stored at on-site ISFSIs. NRC amended its regulations in 1990 allowing licensees to store spent fuel in NRC-certified dry storage casks, at licensed power reactor sites. Section D.1.1 provides additional information on spent fuel storage. Spent fuel also is stored at several research reactor sites licensed by NRC.

Spent fuel from both domestic and foreign research reactors, in addition to limited quantities of commercial spent fuel, is stored at certain DOE sites. DOE continues to receive spent nuclear fuel from foreign and domestic research reactors. The program for receipt of foreign research reactor spent nuclear fuel is to be completed in 2019. No date has been set for completing receipt of spent nuclear fuel from domestic research reactors. DOE stores this spent fuel at its facilities at the Savannah River Site and the Idaho National Laboratory prior to further disposition. DOE also stores spent fuel from former defense production reactors.

#### **B.3.2 Spent Fuel Disposal**

The Nuclear Waste Policy Act (NWPA) of 1982 provides for siting, construction, and operation of deep geologic repositories for the disposal of spent fuel and HLW. NWPA also assigns responsibilities for the disposal of spent fuel and HLW to three Federal agencies:

- DOE for developing permanent disposal capability for spent fuel and HLW;
- EPA for developing generally applicable environmental protection standards; and

---

<sup>19</sup> Some NRC reports are issued as NUREGs.

- NRC for developing regulations to implement EPA standards, deciding whether or not to license construction, operation, decommissioning and closure of the repositories, and certifying packages used to transport spent fuel and HLW to the licensed repositories.

The NWPA, as amended in 1987 (NWPAA), directed DOE to characterize a site at Yucca Mountain, Nevada, for its potential use as a deep geologic repository. Section D.1.2 provides additional information on the proposed repository at Yucca Mountain.

### **B.3.3 Waste Confidence Determination**

NRC made a generic determination, referred to as the Waste Confidence Rule (10 CFR 51.23), that, if necessary, spent fuel generated in any reactor can be stored safely and without significant environmental impacts for at least 30 years beyond the licensed life for operation of that reactor. This 30-year period includes revised or renewed license, as well. This storage can be at a spent fuel storage basin or at an onsite or offsite ISFSI.

NRC further believes there is reasonable assurance that at least one mined geologic repository will be available within the first quarter of the twenty-first century, and sufficient repository capacity will be available within 30 years beyond the licensed life for operation of any reactor to dispose of commercial high-level waste and spent fuel originating in such reactor and generated up to that time.

### **B.3.4 Reprocessing in the United States**

Commercial reprocessing, where plutonium, uranium, or both are recovered from spent fuel to be used again in a reactor, was abandoned in the U.S. in the 1970s because of nuclear proliferation concerns. Several reprocessing ventures were considered in the 1960s and early 1970s. General Electric Company planned construction of a commercial reprocessing facility near Morris, Illinois, in the late 1960s, but only the storage facility was completed, and remains in operation today.

Nuclear Fuel Services operated a reprocessing facility at West Valley New York from 1966 to 1972. This facility processed 640 metric tons of heavy metal (MTHM) from government and commercial nuclear power plants, resulting in 2.3 million liters of liquid HLW. This was the only commercial reprocessing plant operated in the United States. The United States declared a moratorium on domestic spent fuel reprocessing in 1977. The moratorium was rescinded in 1981, but commercial reprocessing never resumed.

DOE announced the Global Nuclear Energy Partnership (GNEP) in 2006. The GNEP is part of an advanced energy initiative through which DOE is exploring alternatives to the current domestic nuclear fuel cycle, some of which involve separations and recycling of spent fuel.<sup>20</sup> See Section K.5 for additional information.

DOE ceased reprocessing of defense spent fuel at two sites and continues reprocessing operations at the Savannah River Site. HLW generated as result of these activities is treated on site and stored pending disposal in the proposed geologic repository.

---

<sup>20</sup> For the latest information see <http://www.gnep.energy.gov>

## **B.4 Radioactive Waste Management Practices**

Radioactive waste in the United States results from a number of activities. Each is discussed in the following sections of this report.

### **B.4.1 Low-Level Waste**

The United States has a comprehensive management system for most LLW. Commercial and government facilities exist for LLW processing, including treatment, conditioning, and disposal. Generators prepare LLW for shipment to licensed disposal facilities. Section D.2.2.2 provides additional information on facilities and inventories of LLW.

Commercial LLW disposal facilities are designed, constructed, and operated under licenses issued by either NRC or an Agreement State, based on NRC health and safety regulations governing waste disposal quantities, forms, and activity levels. See Sections E.2.7.2 and H.1.1 for additional information.

Class A, B and C LLW is disposed in near surface facilities i.e., a land disposal facility in which radioactive waste is disposed of in or within the upper 30 meters of the earth's surface.

GTCC LLW is stored until an adequate method of disposal is established in accordance with the Low Level Radioactive Waste Policy Amendments Act of 1985 (LLRWPA). GTCC LLW is discussed further in Section D.2.1.2 and Section D.2.2.2.

DOE operates disposal facilities for LLW generated by DOE. DOE also uses commercial LLW disposal sites in certain circumstances. These practices are in Section F and Section H.

### **B.4.2 Transuranic Waste**

Transuranic waste is a DOE waste type. See Section B.2.3.2 and Table B-2 for the definition of TRU waste. TRU waste is itself divided into two categories, contact-handled and remote-handled, based on its surface dose rate. Remote-handled TRU waste emits more radiation than contact-handled TRU waste and must be both handled and transported in shielded casks. Section D.2.2.1 provides information on TRU waste disposal.

### **B.4.3 High-Level Waste**

High level waste from commercial reprocessing activities was vitrified and is stored at the former reprocessing plant in West Valley, New York. Defense HLW is stored, managed and treated at three DOE sites. The proposed Yucca Mountain repository, if licensed, will be used for the disposal of HLW and spent fuel disposal. More information on HLW management is in Section D.2.1.1.

#### **B.4.4 Uranium Recovery**

Uranium recovery is the extraction or concentration of uranium from any ore processed primarily for its source material content.<sup>21</sup> This results in waste from uranium solution extraction processes. These wastes usually have relatively low concentrations of radioactive materials with long half-lives. There are three types of uranium recovery facilities in the United States: conventional mills, *in situ* leaching (ISL), and heap leach facilities. At conventional mills, radioactive waste materials are disposed of in impoundments usually located in the vicinity of the mill.

Radioactive waste materials at conventional mills, are disposed of in impoundments usually located in the mill vicinity. Radioactive waste generated at ISLs is ultimately disposed of at an impoundment located at a conventional mill or at a waste disposal facility. The quantity of radioactive waste generated at an ISL is usually relatively small (typically less than 1,000 cubic meters per year). Waste products are typically stored at the facility before being sent to a regulated disposal facility.

Uranium recovery facilities shut down or scaled back operations in the early 1980s, when the price of uranium fell. Many of the previously operating facilities were reclaimed or are in the process of remediating (decommissioning) waste resulting from extracting uranium. The price of uranium has increased significantly over the last three years. The increase in uranium prices, has prompted an interest in developing new uranium recovery facilities and expanding or restarting of existing facilities.

As of calendar year 2007, NRC received three applications to expand or re-start ISLs and three applications for new facilities. These represent the first applications for new uranium recovery facilities in approximately 20 years. It is anticipated that additional applications for uranium recovery facilities will be submitted in 2008 and 2009. See Annex D-3B for additional information. Further discussion of disposal practices is in Section D.2.2.3.

#### **B.4.5 Waste from Enrichment and Fuel Fabrication Facilities**

The product from uranium recovery facilities is processed to enrich the fissile content. Tailings containing depleted uranium are a byproduct of the enrichment process. Fuel manufacturing facilities fabricate nuclear fuel assemblies for light water reactors containing low enriched uranium. This activity includes receipt, possession, storage, and transfer of special nuclear material. Other licensed activities supporting fuel manufacturing include uranium storage, scrap recovery, waste disposal, and laboratory services. Radioactive waste from these processes, which varies in type and amount, is managed within the classes described in Table B-1, e.g., Class A LLW.

Depending on available quantities, long-term and short-term needs, and cost/benefit analysis of potential uses, DU could be a resource for variety of applications and uses, in which case it is considered source material. If DU is not a resource, NRC categorizes it as Class A LLW; however, NRC is examining whether the disposal of large quantities of DU from enrichment plants warrants amending the 10 CFR Part 61 waste classification tables.

---

<sup>21</sup>Similarly, thorium was also extracted or processed in the past.

Depleted uranium is currently possessed and stored by DOE and private corporations (e.g., U.S. Enrichment Corporation). DOE manages a large stock of DU at two gaseous diffusion enrichment plants. Facilities are being constructed at Paducah, Kentucky and Piketon, Ohio to convert depleted uranium hexafluoride to oxide. Depleted uranium from Oak Ridge, Tennessee, was shipped to the Portsmouth conversion facility. This depleted uranium continues to be managed as source material available for reuse. If a decision is made that this material has no potential use, it can be disposed in DOE or commercial low-level radioactive waste disposal facilities, provided the waste meets the disposal facility's waste acceptance requirements. Some DOE depleted uranium has been disposed as LLW at the Nevada Test Site.

DOE is planning to disposition its inventory of surplus weapons-usable plutonium to address nonproliferation goals with Russia, as well as facilitate closure of former weapons complex sites. A disposition path for some of the DOE surplus weapons-usable plutonium will involve fabricating the plutonium into mixed oxide (MOX) fuel for use in commercial reactors. The irradiated plutonium remaining in the spent fuel cannot be easily re-used for nuclear weapons. Spent MOX fuel would be disposed in a geologic repository. Other radioactive waste generated during fabrication will be disposed of in DOE facilities.

#### **B.4.6 Ocean Disposal**

The United States disposed of some LLW in the ocean in the 1950s and 1960s. This activity, while not specifically regulated, was an accepted method for managing low-level radioactive waste.<sup>22</sup> Authority for such disposals was derived later from the Marine Protection, Research, and Sanctuaries Act of 1972 (MPRSA), authorizing EPA to issue permits and promulgate regulations for disposing of materials into the territorial waters of the United States. Such disposal could not degrade or endanger human health, welfare, ecological systems, the marine environment, or the economy. It specifically prohibited ocean disposal of HLW. Any request for ocean disposal of LLW requires a permit approved by both houses of Congress.<sup>23</sup> EPA issued regulations specifying conditions for permitting ocean disposal of LLW on January 11, 1977.<sup>24</sup> However, no applications for such a permit have been submitted. Ocean disposal of U.S. LLW was discontinued in 1970.

The United States signed the London Convention in October 1993. This international agreement, which remains in force until 2018, places prohibitions on disposing of radioactive materials at sea. After that time, the sub-seabed disposal option can be revisited at 25-year intervals. The United States is a Contracting Party to the protocol developed in 1996 to amend the London Convention to ban ocean disposal of radioactive wastes and incineration at sea.

---

<sup>22</sup>Radiation Protection at EPA: The First 30 Years. EPA 402-B-00-001, August 2000 at URL: <http://www.epa.gov/radiation/docs/402-b-00-001.pdf>

<sup>23</sup>Marine Protection, Research, and Sanctuaries Act, 33 USC 1801 et seq., 1972.

<sup>24</sup>U.S. Environmental Protection Agency, *40 CFR 220, Ocean Dumping, Final Revision of Regulations and Criteria*, in the *Federal Register* 42 FR 2462, January 11, 1977.

## B.5 Decommissioning

Decommissioning is an activity generally taking place at the end of operation of commercial and governmental nuclear facilities. NRC and other governmental agencies' recommendations, and in some cases requirements, include provision for decommissioning planning in the pre-operational design and strategy. Waste from decommissioning is managed within the waste classes in Table B-1 and Table B-2. See Section F.6 for additional information.

NRC regulations (10 CFR 20.1406) specifically require applicants for licenses to describe how facility design and procedures will facilitate eventual decommissioning. Furthermore, NRC's decommissioning group is working closely with industry, NRC stakeholders, and members of the public to ensure lessons learned from decommissioning can be appropriately factored into the next generation of nuclear facilities (e.g., nuclear power plants, uranium mill facilities, etc.). NRC has published regulatory guidance in Regulatory Guide 4.21, *Minimization of Contamination and Radioactive Waste Generation: Life Cycle Planning*, June 2008 for implementing this requirement.<sup>25</sup>

---

<sup>25</sup> See: <http://www.nrc.gov/reading-rm/doc-collections/reg-guides/environmental-siting/active/> or from ADAMS accession number [ML080500187](#).

This page intentionally left blank



## C. SCOPE OF APPLICATION

This section covers the application of the Joint Convention in the United States (Article 3), the U.S. position on the application of the Joint Convention to reprocessing of spent fuel, naturally occurring radioactive material, and defense/ military programs. This section also provides a definition of what the United States considers spent fuel and waste management facilities under the provisions of the Joint Convention.

### C.1 Application to Reprocessing of Spent Fuel

The United States has no commercial reprocessing facilities. No declaration is, therefore, needed under Article 3.1. If a decision is made in the future to proceed with construction of a reprocessing facility, the United States will make a declaration under Article 3.1 then.

### C.2 Application to Naturally Occurring Radioactive Materials

The Joint Convention does not apply to naturally occurring radioactive materials (NORM) originating outside the nuclear fuel cycle, except when a disused sealed source containing naturally occurring radioactive material is declared as radioactive waste by the Contracting Party (Article 3.2). As discussed in Section B.2.3.3, certain discrete sources of radium, other NORM, and ARM are regulated as byproduct material, but not as radioactive waste within the context of the Joint Convention.

The United States complies with the Joint Convention by reporting on waste from the mining of uranium and thorium ores. It also considers technologically enhanced NORM (TENORM) materials in the same category as NORM for Joint Convention purposes. The United States does not consider diffuse sources of NORM generated outside the nuclear fuel cycle to be within the scope of the Joint Convention.

### C.3 Application to Defense Activities

The Joint Convention does not apply to the safety of spent fuel or waste within defense or military programs unless declared specifically (Article 3.3). The U.S. Government has determined the Joint Convention does not apply to spent fuel or waste managed within the military programs in the United States, but spent fuel and radioactive waste from military programs fall within the Joint Convention when transferred for permanent disposal in facilities operated by DOE.

United States military programs are primarily in the U.S. Department of Defense and the National Nuclear Security Administration (NNSA). The NNSA is a separately organized agency within DOE, overseeing the military application of nuclear energy; maintaining

A.	Introduction
B.	Policies & Practices <ul style="list-style-type: none"><li>Article 32, paragraph 1</li></ul>
C.	<b>Scope of Application</b> <ul style="list-style-type: none"><li>Article 3.</li></ul>
D.	Inventories & Lists <ul style="list-style-type: none"><li>Article 32, paragraph 2</li></ul>
E.	Legislative & Regulatory Systems <ul style="list-style-type: none"><li>Article 18. Implementing Measures</li><li>Article 19. Legislative &amp; Regulatory Framework</li><li>Article 20. Regulatory Body</li></ul>
F.	General Safety Provisions <ul style="list-style-type: none"><li>Article 21. Responsibility of License Holder</li><li>Article 22. Human &amp; Financial Resources</li><li>Article 23. Quality Assurance</li><li>Article 24. Operational Radiation Protection</li><li>Article 25. Emergency Preparedness</li><li>Article 26. Decommissioning</li></ul>
G.	Safety of Spent Fuel Management <ul style="list-style-type: none"><li>Article 4. General Safety Requirements</li><li>Article 5. Existing Facilities</li><li>Article 6. Siting of Proposed Facilities</li><li>Article 7. Design &amp; Construction of Facilities</li><li>Article 8. Facility Safety Assessment</li><li>Article 9. Facility Operation</li><li>Article 10. Spent Fuel Disposal</li></ul>
H.	Safety of Radioactive Waste Management <ul style="list-style-type: none"><li>Article 11. General Safety Requirements</li><li>Article 12. Existing Facilities &amp; Past Practices</li><li>Article 13. Siting of Proposed Facilities</li><li>Article 14. Design &amp; Construction of Facilities</li><li>Article 15. Facility Safety Assessment</li><li>Article 16. Facility Operation</li><li>Article 17. Institutional Measures After Closure</li></ul>
I.	Transboundary Movement <ul style="list-style-type: none"><li>Article 27.</li></ul>
J.	Disused Sealed Sources <ul style="list-style-type: none"><li>Article 28.</li></ul>
K.	Planned Activities to Improve Safety
	Annexes

and enhancing the safety, reliability, and performance of the U.S. nuclear weapons stockpile; and developing of naval propulsion plants for the U.S. Navy, among other functions.

The amount of spent fuel and radioactive waste from military programs is relatively small compared to the commercial nuclear power sector. Spent fuel and waste in military programs are managed, however, in accordance with the objectives stated in Article 1 of the Joint Convention.

The Joint Convention applies when waste and spent fuel are permanently transferred to an exclusively civilian program. The Joint Convention will apply to naval reactor spent fuel when accepted for disposal in the proposed geologic repository at Yucca Mountain, along with commercial spent fuel. The safety case for disposal of spent fuel and high-level waste (HLW) from Federal government programs is addressed in DOE's Yucca Mountain license application, since these will be co-disposed with commercial waste.

#### **C.4 Application to Radioactive Waste and Spent Fuel Management Facilities**

The Joint Convention defines radioactive waste management as all activities, including decommissioning, handling, pretreatment, treatment, conditioning, storage, and disposal excluding off-site transportation. The United States has both commercial and Government radioactive waste management facilities under the Joint Convention.

The Joint Convention defines storage as holding radioactive waste in a facility for containment, with the intention of retrieval. The United States does not consider facilities as radioactive waste storage facilities where, for a short period of time (less than a year), a waste generator collects radioactive waste for shipment or processing before sending it to a treatment or disposal facility. This excludes a large number of interim storage facilities at nuclear power plants, hospitals, universities, research facilities, industries, etc., where radioactive waste is generated and shipped to disposal sites. These facilities are subject to the regulations under licenses to possess nuclear materials. All such facilities, though not reported, subscribe to the same objectives of Article 1 of the Joint Convention.

The Joint Convention allows Contracting Parties to include the storage of spent fuel at reactor sites as spent fuel management facilities, since they generally provide storage longer than one year, with the ultimate disposal at a geologic repository.

Article 3 of the Joint Convention allows Contracting Parties to declare facilities undergoing decommissioning as radioactive waste management facilities. The United States has facilities in the decommissioning phase declared as waste management facilities by constructing on-site disposal facilities for some of the radioactive waste being generated during cleanup activities. This report further discusses ongoing decommissioning (including site remediation) activities in Section D.3 and F.6.

## D. INVENTORIES AND LISTS

This section covers U.S. obligations under Joint Convention Article 32, Paragraph 2, to report:

i. <i>a list of the spent fuel management facilities subject to this Convention, their location, main purpose, and essential features</i>	D.1
ii. <i>an inventory of spent fuel subject to this convention and being held in storage, and spent fuel disposed...a description of the material and...information on its mass and total activity</i>	
iii. <i>a list of the radioactive waste management facilities subject to this Convention, their location, main purpose and essential features</i>	D.2
iv. <i>an inventory of radioactive waste subject to this Convention and being held in storage at radioactive waste management and nuclear fuel cycle facilities; has been disposed of; or has resulted from past practices...and a description of the material and other appropriate information available, such as volume or mass, activity, and specific radionuclides</i>	
v. <i>a list of nuclear facilities being decommissioned and the status of decommissioning activities at those facilities</i>	D.3

Radioactive waste inventories reported in this section are classified according to the waste classification definitions described in Section B of this report.

### D.1 Spent Fuel Management

Most U.S. commercial spent fuel will remain at nuclear power plants until the proposed geologic repository at Yucca Mountain is operating. Some spent fuel is also being stored away from nuclear power plants. The Joint Convention also applies to the Department of Energy (DOE) Government spent fuel storage facilities, including those used to store foreign research reactor and U.S. research reactor spent fuel transferred to DOE. Radioactive waste management practices are discussed in Sections F and G.

#### D.1.1 Spent Fuel Storage

Dry storage systems were developed as the preferred alternative (versus new pool construction). Spent fuel is loaded in canisters with inert gas with either welded or bolted closures. Canisters are then placed in casks or vaults/bunkers. Some cask designs can be used for both storage and transportation.

Designers and manufacturers must comply with the quality assurance (QA) requirements in 10 CFR Part 72 Subpart G. The Nuclear Regulatory Commission (NRC) inspects designers, manufacturers, and licensees to verify quality assurance procedures comply with their approved QA plan, and fabrication and use is done according to their QA program.

- A. Introduction
- B. Policies & Practices
  - Article 32, paragraph 1
- C. Scope of Application
  - Article 3.
- D. Inventories & Lists**
  - Article 32, paragraph 2
- E. Legislative & Regulatory Systems
  - Article 18. Implementing Measures
  - Article 19. Legislative & Regulatory Framework
  - Article 20. Regulatory Body
- F. General Safety Provisions
  - Article 21. Responsibility of License Holder
  - Article 22. Human & Financial Resources
  - Article 23. Quality Assurance
  - Article 24. Operational Radiation Protection
  - Article 25. Emergency Preparedness
  - Article 26. Decommissioning
- G. Safety of Spent Fuel Management
  - Article 4. General Safety Requirements
  - Article 5. Existing Facilities
  - Article 6. Siting of Proposed Facilities
  - Article 7. Design & Construction of Facilities
  - Article 8. Facility Safety Assessment
  - Article 9. Facility Operation
  - Article 10. Spent Fuel Disposal
- H. Safety of Radioactive Waste Management
  - Article 11. General Safety Requirements
  - Article 12. Existing Facilities & Past Practices
  - Article 13. Siting of Proposed Facilities
  - Article 14. Design & Construction of Facilities
  - Article 15. Facility Safety Assessment
  - Article 16. Facility Operation
  - Article 17. Institutional Measures After Closure
- I. Transboundary Movement
  - Article 27.
- J. Disused Sealed Sources
  - Article 28.
- K. Planned Activities to Improve Safety
- Annexes

There are two primary canister-based dry cask storage systems for spent fuel. One spent fuel design involves placing canisters vertically or horizontally in a concrete vault radiation shield. The other design places canisters vertically on a concrete pad and uses both metal and concrete outer cylinders for radiation shielding. Figure D-1 shows typical dry cask storage systems.

*At some nuclear reactors across the country, spent fuel is kept on site, above ground, in systems basically similar to the one shown here.*

**1** Once the spent fuel has cooled, it is loaded into special canisters, each of which is designed to hold about two dozen assemblies. Water and air are removed. The canister is filled with inert gas, welded shut, and rigorously tested for leaks. It may then be placed in a "cask" for storage or transportation.

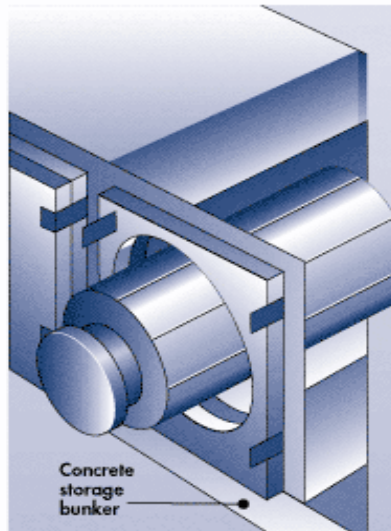
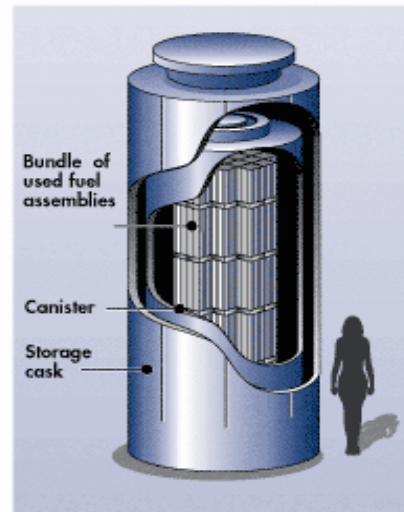

**2** The canisters can also be stored in above-ground concrete bunkers, each of which is about the size of a one-car garage. Eventually they may be transported elsewhere for storage.

Figure D-1 Typical Dry Cask Storage Systems

Table D-1 summarizes the types and numbers of U.S. spent fuel storage facilities and a complete list of spent fuel storage facilities is provided in Annex D-1. Figure D-2 shows the location of ISFSIs and other spent fuel storage facilities.

NRC regulations convey a general license to nuclear power reactor licensees to store spent fuel in dry storage systems approved by NRC at a site already licensed to operate a nuclear power reactor under 10 CFR Part 50. NRC has already approved a variety of dry storage systems potential licensees may consider. These systems have Certificates of

Compliance and are listed in NRC regulations (10 CFR 72.214). No applications or Safety Analysis Reports are required for a license to use these designs.

The U.S. commercial nuclear power industry had generated about 58,370 metric tons heavy metal (MTHM) of spent fuel as of the end of 2007. About 10,200 MTHM of this spent fuel were in dry cask storage at commercial nuclear power plant sites. About 2,440 MTHM of spent fuel is stored at government facilities. Table D-1 summarizes spent fuel storage inventories. Annex D-1 provides the most recent available detailed spent fuel inventories (as of 2007). These inventories are updated annually.

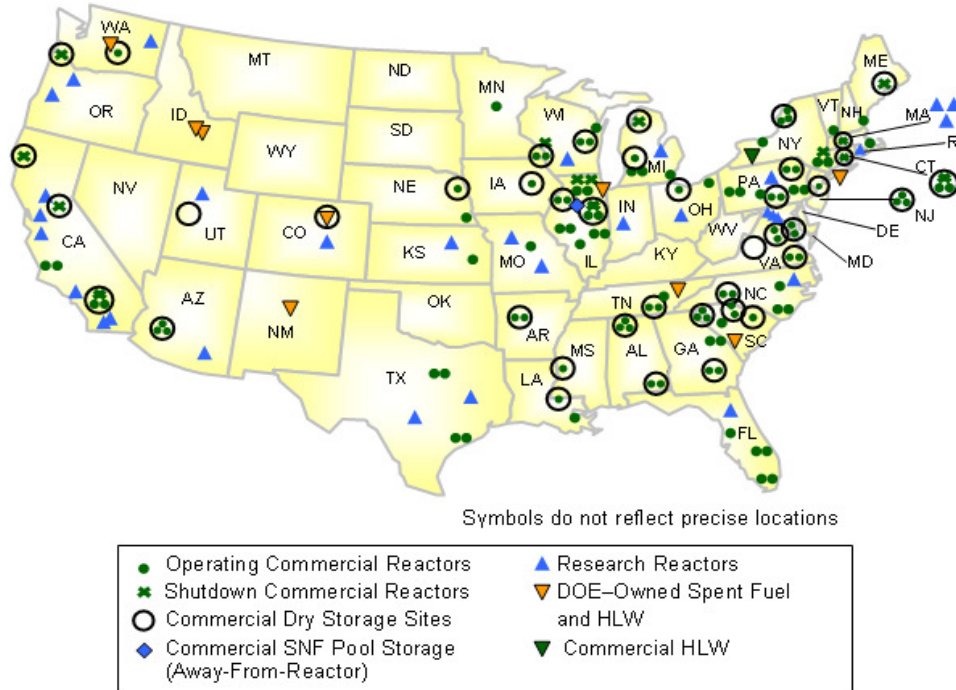

Figure D-2 Location of U.S. Spent Fuel and HLW Storage Installations

Nearly 20 percent of all commercial spent fuel assemblies were stored in dry casks at ISFSIs as of December 2007. This percentage is expected to increase as more commercial utility spent fuel pools reach capacity. Most reactors were not designed to store all the spent fuel generated during their operating lives, and contribute between 1,800 and 2,200 MTHM annually to the growing inventory. Projected spent fuel discharges (taking into account plant life extensions) could bring the total waste inventory to 130,000 MTHM by the year 2055.

Table D-1 Spent Fuel Storage Facilities			
Sector	Function	Number of Facilities <sup>26</sup>	Inventory (MTHM <sup>27</sup> )
Government	Pool Storage	7	38.5
	Dry Cask Storage <sup>28</sup>	5	2,400
	Research and Test Reactors	4	<1
Commercial	University Research Reactors	23	≈1
	Other Research and Test Reactors	5	<1
	At-Reactor Storage Pools	97	47,500 <sup>29</sup>
	Independent Spent Fuel Storage Facilities (Dry Cask) <sup>30</sup>	41	10,200
	Independent Spent Fuel Storage Facilities (Pool)	1	670

### D.1.2 Spent Fuel Disposal

The Nuclear Waste Policy Act of 1982 (NWPA) provides for the siting, construction, and operation of deep geologic repositories for disposal of spent fuel and high-level radioactive waste. Such repositories would be licensed by NRC. Congress passed the Nuclear Waste Policy Amendments Act in 1987, directing DOE to discontinue studying all other sites, and to study the site at Yucca Mountain, Nevada exclusively to determine its suitability as a potential repository.

The President signed a Congressional Joint Resolution on July 23, 2002, designating the Yucca Mountain site be developed as a geologic repository based on the results of more than 20 years of intensive science and engineering work. DOE submitted a license application to NRC on June 3, 2008, for authorization to construct a repository at Yucca Mountain. NRC docketed the license application on September 8, 2008, and issued a *Federal Register* notice on September 15, 2008, announcing the NRC Staff's conclusion that it is practicable for the NRC to adopt DOE's 2002 *Final Environmental Impact Statement for a Geologic Repository for the Disposal of Spent Nuclear Fuel and High-Level Radioactive Waste at Yucca Mountain, Nye County, Nevada*, and the 2008 supplements prepared by DOE, with additional supplementation.

NRC will evaluate the license application in accordance with the regulations developed pursuant to the NWPA and the Energy Policy Act of 1992 (EnPA), including 10 CFR Part 63 (Disposal of HLW in a Geologic Repository at Yucca Mountain, Nevada). DOE will be required, as part of the licensing process, to demonstrate the proposed repository meets regulatory radiation protection standards established by EPA pursuant to EnPA. EnPA required EPA to set site-specific standards to protect public health and safety from releases of radioactive material stored or disposed of in the repository at the

<sup>26</sup> In some instances multiple facilities at a given installation are counted as a single facility.

<sup>27</sup> Metric tons of heavy metal is the conventional measure of fuel mass in nuclear reactor fuel assemblies.

<sup>28</sup> Includes NRC-licensed Dry Cask Storage facility at Idaho National Laboratory.

<sup>29</sup> U.S. Department of Energy data as of Dec 31, 2007 for spent fuel in pools at commercial reactor sites.

<sup>30</sup> Includes government held licensed facilities for commercial fuel at Fort St. Vrain in Colorado and the BWXT fuel fabrication facility in Virginia.

Yucca Mountain site. EnPA requires NRC to incorporate EPA's final Yucca Mountain standards into 10 CFR Part 63. NRC's decision whether or not to issue the license will be based on the results of a comprehensive safety review and on a full and fair public hearing.

Yucca Mountain is located about 145 kilometers northwest of Las Vegas, Nevada, on unpopulated desert land owned by the Federal government. The long-term average precipitation is about 19 centimeters per year. Yucca Mountain itself is a ridge of tilted layers of volcanic rock, called tuff, deposited by a series of eruptions about 11 to 14 million years ago. Geological mapping of the surface and other studies show faults are present in the vicinity of Yucca Mountain. The host rock for the proposed repository is a welded tuff unit located about 300 meters below the surface and 300 meters above the water table.

DOE's Office of Civilian Radioactive Waste Management (OCRWM) announced on October 25, 2005, it would devise a plan to operate the Yucca Mountain repository primarily as a canister handling facility which would significantly reduce the potential for contamination. The design change means most spent fuel will be delivered to the repository in canisters designed for transport, aging, and disposal (TAD). TADs will be placed in waste packages for emplacement. The canisters and waste package designs will require integration, prototype development, licensing and testing in accordance with NRC standards. Certification of the TAD for transport and storage is the responsibility of NRC under 10 CFR Parts 71 and 72, respectively. Figure D-3 shows a conceptual view of the waste package for disposal.

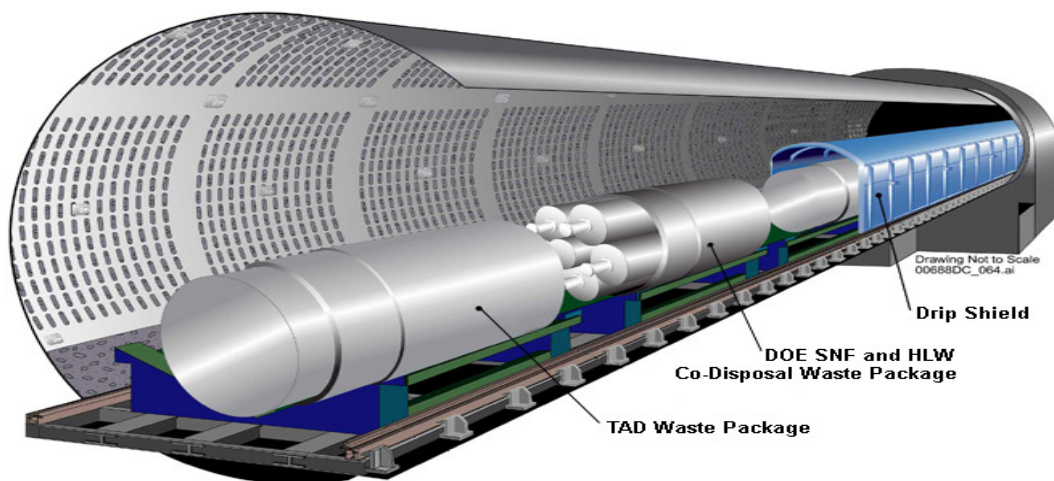

Figure D-3 Conceptual View of Waste Package Emplacement for Disposal at Yucca Mountain

NWPA limits emplacement of waste at the first geologic repository to 70,000 MTHM until a second repository is in operation. Spent fuel and HLW disposed at Yucca Mountain are expected to include about 63,000 MTHM of commercial spent fuel, and 7,000 MTHM from defense related activities (about 2,300 MTHM of DOE spent fuel, and the equivalent of about 4,700 MTHM of DOE HLW). Assuming all 104 currently operating reactors receive 20-year life extensions, it is projected that by completion of their life cycles, the total SNF and HLW inventory could be as much as 130,000 MTHM by 2055.

DOE evaluated a larger than 70,000 MTHM capacity repository in its Final Environmental Impact Statement (FEIS) of 2002 and its Supplemental Environmental Impact Statement (SEIS) for a Yucca Mountain Repository (issued in June 2008).

Design objectives of the repository are to: (1) protect the health and safety of both the workers and the public during the period of repository operations; (2) minimize the amount of radioactive material reaching the accessible environment; and (3) minimize life cycle costs. The repository's design will permit it to be kept open, with only routine maintenance for 100 years after the start of waste emplacement. This includes 50 years for receipt and emplacement operations and an additional 50-year period after receipt and emplacement. Keeping the repository open means the underground emplacement areas can be directly inspected and the waste packages readily removed, if necessary.

## D.2 Radioactive Waste Management

Section D.2.1 describes waste storage and treatment facilities and their associated inventories. Section D.2.2 describes disposal facilities in the United States.

### D.2.1 Radioactive Waste Storage and Treatment

Radioactive wastes are treated primarily to produce a structurally stable, final waste form and minimize the release of radioactive and hazardous components. The United States does not commonly make a distinction between the terms treatment and conditioning. Conditioning is defined in the international community as an operation producing a waste package suitable for handling, such as conversion of a liquid to a solid, enclosure of the waste in containers, or overpacking. Treatment is defined as operations intended to improve the safety and/or economy by changing the characteristics of the waste through volume reduction, removal of radionuclides, and change in composition. U.S. terminology covering both conditioning and treatment is generally referred to as treatment or processing. Treatment is used in this broader context in this report.

Table D-2 summarizes the U.S. radioactive waste treatment and storage facilities and the inventory in storage as of the end of 2007. Annex D-2 provides a list of facilities, their location, main purpose, and essential features. The following sections provide a brief description of the major types of radioactive waste management facilities.

Sector	Function	Waste/Material Type	Number <sup>32</sup>	Inventory
Government	Storage/Treatment	HLW	8	357,000 m <sup>3</sup>
		TRU	14	97,000 m <sup>3</sup>
		LLW <sup>33</sup>	20	43,000 m <sup>3</sup>
		11e.(2)	1	195,000 m <sup>3</sup>
Commercial	Treatment/Processing	LLW	44	Small volumes for collection
	Storage	11e.(2)	1	21,200 m <sup>3</sup>

<sup>32</sup>In some instances multiple facilities at a given installation are counted as a single facility.

<sup>33</sup>Includes Mixed LLW.



### D.2.1.1 HLW Storage and Treatment

Waste is stored at four sites where it was generated from reprocessing of spent fuel. All 2,270 cubic meters (600,000 gallons) of HLW generated from reprocessing at the former commercial reprocessing plant at West Valley, New York, between 1966 and 1972 was vitrified into 275 ten-foot tall stainless steel canisters of borosilicate glass, and is awaiting disposal in the proposed geologic repository.

HLW from reprocessing defense materials at the Savannah River Site consists of both insoluble solid chemicals and water soluble salts. The waste is stored in underground stainless steel tanks until treated. The insoluble solids settle and accumulate on the bottom of these tanks as “sludge.” Liquid above the sludge is concentrated by evaporation to reduce its volume. The concentrate left behind is a damp “salt cake.” About 378,000 cubic meters (100 million gallons) of high-level waste was concentrated by evaporation to a volume of about 140,000 cubic meters. The remaining sludge (containing most of the radioactivity), along with the radioactive cesium removed from the salt solution, was or is being transferred to the site’s Defense Waste Processing Facility (DWPF) for immobilization in borosilicate glass. The DWPF began processing HLW on March 12, 1996; and will continue operations until all HLW is processed. There were 2,056 canisters of vitrified HLW stored at Savannah River Site (as of August 2008) awaiting disposal in the proposed geologic repository. Each canister is 3 meters (10 feet) tall and 0.6 meters (2 feet) in diameter. It takes about 24 hours to fill one canister. A filled canister weighs about 2.3 metric tons (2.5 tons).

Reprocessing defense materials at the Hanford Site began in 1944, and ended nearly 50 years later resulting in 200,000 cubic meters (53 million gallons) of radioactive waste stored in 177 underground tanks. The waste consists of sludge, supernate, and salt cake. Some tanks are over 60 years old and have leaked waste into the soil. The waste must be removed and processed to a form suitable for disposal, and the tanks stabilized to protect the Columbia River. DOE plans to process the tank waste and dispose the high-level portion (vitrified HLW) at the proposed geologic repository. The interim stabilization of all single-shell tanks has been completed (all pumpable liquids removed), and remaining waste is being retrieved from these tanks in preparation for interim closure. Seven tanks have been fully emptied and stabilized. Design and construction of the Waste Treatment Plant, which includes a pretreatment facility, low-activity waste treatment facility,<sup>34</sup> high-level waste facility, and analytical laboratory is progressing with HLW vitrification scheduled to begin in 2019.

HLW from more than 50 years of defense spent fuel reprocessing at Idaho National Laboratory has been stored in tanks and treated for disposal. The tank farm contains 3,400 cubic meters (900,000 gallons) of waste (referred to as sodium-bearing waste). Four tanks have been closed to date. Much of the waste was previously treated and is now stored as dry granular calcine (4,400 cubic meters) in stainless steel bins. The remaining liquid HLW contains a high concentration of sodium, and will be treated by steam reforming by the end of 2012.

Residual waste in the tanks at Hanford, Idaho and Savannah River has been managed as HLW. DOE may determine certain quantities of this residual waste from reprocessing

---

<sup>34</sup> Facility will treat a separated fraction of the HLW with lower levels of radioactivity.

are not HLW if certain conditions are met.<sup>35</sup> DOE consults with NRC prior to making such determinations and depending on the location, follows the process set forth in section 3116 of the National Defense Authorization Act (NDAA) for Fiscal Year 2005 or the Waste Incidental to Reprocessing (WIR) provisions of DOE Manual 435.1-1, *Radioactive Waste Management*.

### **D.2.1.2 Greater-Than-Class C Low-Level Waste Management**

Greater-than-Class C (GTCC) waste is a form of low-level radioactive (LLW) waste containing long- and short-lived radionuclides with properties requiring a more robust disposal strategy<sup>36</sup> than for other classes of LLW. The authority to possess this type of radioactive material is included in NRC or Agreement State licenses. GTCC waste may generally be grouped into the following three types: sealed sources, activated metals, and other waste. Other GTCC waste includes contaminated equipment, trash, and scrap metal from miscellaneous industrial activities, such as manufacturing of sealed sources and laboratory research. Most GTCC waste is generated by decommissioning nuclear power plants, and excess or unwanted sealed sources. Typical radionuclides associated with GTCC waste are <sup>14</sup>C, <sup>59</sup>Ni, <sup>94</sup>Nb, <sup>99</sup>Tc, <sup>55</sup>Fe, <sup>90</sup>Sr, <sup>239</sup>Pu, and <sup>137</sup>Cs.

The GTCC LLW is being stored until an adequate disposal method is established in accordance with the Low-Level Radioactive Waste Policy Amendments Act of 1985 (LLRWPA). The current estimate for stored and projected GTCC LLW is 2,600 m<sup>3</sup>. This includes GTCC LLW from the decommissioning of commercial nuclear reactors.<sup>37</sup> In addition, there is approximately 2,500 m<sup>3</sup> of DOE LLW and transuranic (TRU) waste with characteristics similar to GTCC LLW and which also does not have an identified path to disposal. Most of this waste is TRU waste that may have originated from non-defense activities and, therefore, may not be authorized for disposal at the Waste Isolation Pilot Plant under current legislation. The construction of new commercial reactors and other proposed actions could generate additional quantities of GTCC LLW. The LLRWPA assigned the Federal government responsibility for disposal of GTCC LLW that results from NRC-licensed activities and directed that GTCC LLW be disposed in a NRC-licensed facility. There are no facilities currently licensed by NRC for the disposal of GTCC LLW. In addition, the Energy Policy Act of 2005 requires DOE to complete several actions related to the preparation of an EIS and Record of Decision for the disposal of GTCC LLW.

DOE is performing the National Environmental Policy Act analyses of potential GTCC LLW disposal alternatives, including developing of an EIS. DOE issued a Notice of Intent (NOI) on July 23, 2007, to prepare the GTCC EIS. DOE conducted a public scoping process from July 23 to September 21, 2007. Nine public scoping meetings were held, and comments on the proposed disposal alternatives, waste inventories, and other issues related to the scope of the GTCC EIS were received from the public and other stakeholders. DOE is preparing a Draft EIS considering comments received during the public scoping process. This EIS will consider alternatives for disposal in a

<sup>35</sup> The criteria in Section 3116 of the National Defense Authorization Act of 2005 are applicable to wastes in the states of South Carolina and Idaho only. The criteria for DOE wastes in other states are in DOE Manual 435.1-1, Chapter II, Section B.

<sup>36</sup> In the context of the National Report, "more robust" connotes a greater degree of isolation, durability, and performance than is associated with near surface disposal for other classes of low-level radioactive wastes. This could include intermediate level waste as defined by some nations.

<sup>37</sup> Additional information can be found at [www.gtccceis.anl.gov](http://www.gtccceis.anl.gov).

geologic repository, intermediate depth boreholes, and enhanced near-surface facilities. It will also address candidate locations in various States. The public will have the opportunity to comment on the draft EIS. DOE must issue a report to Congress describing the disposal alternatives under consideration and await action by Congress before DOE can issue a final decision on its preferred disposal alternative.

### **D.2.1.3 LLW Storage and Treatment**

Commercial generators of LLW waste in the United States must treat these wastes to remove free liquids, stabilize or destroy other hazardous components contained in the waste. Wastes are also often treated to reduce the final disposal volume through compaction and incineration. Private companies in the United States provide processing (e.g. packaging and treatment) and brokerage services to facilitate safe storage, transportation and, ultimately, disposal of LLW at one of three commercial disposal facilities. Some of these waste processor/brokers serve limited clientele. Others perform these services for a wider body of clients. Annex D-2 includes a number of these processors.

Many U.S. commercial generators of LLW could no longer dispose of their Class B and C low-level radioactive waste in July 2008, when the Barnwell LLW disposal facility in the state of South Carolina limited its service to three U.S. states.<sup>38</sup> In anticipation of this circumstance, the NRC is in the process of updating its guidance<sup>39</sup> related to extended interim storage of LLW. For materials and fuel cycle licensees, NRC is in the process of updating its guidance related to long-term storage of LLW. For materials and fuel cycle licensees, NRC has updated considerations for extended interim storage in the form of a Regulatory Issue Summary.<sup>40</sup> For nuclear power licensees, NRC is in the process of reviewing guidance prepared on behalf of the Nuclear Energy Institute (NEI), and, if appropriate, incorporating the NEI guidance into NRC guidance.

### **D.2.2 Radioactive Waste Disposal**

DOE plans to dispose of HLW along with spent fuel in the proposed geologic repository. See Section D.1.2 for additional information. The cumulative inventory of disposed radioactive waste as of September 30, 2007, is shown in Table D-3. Annex D-2 provides more detailed information on the quantities for each disposal facility.

---

<sup>38</sup> Referred to as the Atlantic LLW Compact.

<sup>39</sup> Information Notice No. 90-09: Extended Interim Storage of Low-Level Radioactive Waste by Fuel Cycle and Materials Licensees. February 1990.

<sup>40</sup> Regulatory Issue Summary 2008-12, May 9, 2008, *Considerations for Extended Interim Storage of Low-Level Radioactive Waste by Fuel Cycle and Materials Licensees*. (Available from the ADAMS - ML073330725)

Sector	Facility Type	Waste Type	Number	Inventory
Government/ Commercial	Geologic Repository (Yucca Mountain in licensing)	HLW (and Spent Fuel)	1	0
Government	Geologic Repository (WIPP)	TRU	1	56,000 m <sup>3</sup>
	Closed NTS Greater Confinement Disposal (boreholes)	TRU	1	200 m <sup>3</sup>
	Near Surface Disposal	LLW <sup>41</sup>	19	6,800,000 m <sup>3</sup>
Commercial	Operating Near Surface Disposal	LLW (Class A, B, C)	3	3,920,000 m <sup>3</sup>
		11e.(2)	1	1,230,000 m <sup>3</sup>
	Closed Near Surface Disposal	LLW	4	438,000 m <sup>3</sup>
Government/ Commercial	Title I UMTRCA Disposal	Residual Radioactive Material (tailings)	20	243,000,000 Metric Tons
Commercial	Title II UMTRCA Disposal	11e.(2)	41	
Government	Other Closed Disposal Cells (Weldon Spring Site and Monticello)	Residual Radioactive Material (tailings)	2	3,120,000 m <sup>3</sup>

### D.2.2.1 Transuranic Waste Disposal

WIPP is a geologic repository to dispose, safely and permanently, TRU radioactive waste left from the research and production of nuclear weapons. WIPP began operations on March 26, 1999, after more than 20 years of scientific study, public input, and regulatory review.

WIPP is located in southeastern New Mexico, about 80 kilometers from Carlsbad. The repository consists of disposal rooms mined 655 meters underground in a 600-meter thick salt formation. This formation has been stable for more than 200 million years. WIPP-bound TRU waste is currently stored at 14 locations nationwide. Approximately 56,000 cubic meters of TRU waste were disposed at WIPP as of August 2008.

In the Energy and Water Development Appropriations Act of 2004, Congress mandated that the Secretary of Energy submit a WIPP permit modification request limiting the characterization requirements for all TRU waste received for storage and disposal. The New Mexico Environment Department (NMED), in the resulting Permit, issued on October 16, 2006, incorporated Congressionally mandated changes for confirming Resource Conservation and Recovery Act-regulated (RCRA) constituents in TRU. Permit approval also resulted in: (1) allowance of RH-TRU disposal at WIPP; (2) a new waste analysis plan; (3) increased container storage areas; (4) increased capacity for disposal panels; (5) room-based volatile organic compound monitoring; (6) a new dispute resolution process; and (7) e-mail public notification requirements. WIPP began accepting defense-generated RH-TRU waste on January 22, 2007. A limit of 7,079

<sup>41</sup>Includes Mixed LLW.

cubic meters of RH-TRU waste can be disposed in WIPP. The disposal limit, as defined in the WIPP Land Withdrawal Act (WIPP LWA), is 175,600 cubic meters.

DOE initiated its first RH-TRU shipment on January 19, 2007. The first shipment arrived at WIPP on January 22, 2007. DOE has now increased RH-TRU shipments to WIPP to as many as four shipments per week. DOE is actively working to start RH-TRU shipments from additional sites.

WIPP has the capacity to accept all DOE defense contact-handled and RH-TRU waste in storage and projected future waste generation. WIPP is authorized only to receive TRU waste from defense-related activities. DOE is currently assessing disposal alternatives, including potential disposal at WIPP, for other TRU waste and GTCC LLW. This TRU waste is stored at five additional sites and accounts for approximately an additional 50,000 cubic meters. See Section D.2.1.2 for additional information. DOE will make a recommendation to the Congress, and must await feedback prior to making a decision.

#### **D.2.2.2 Low-Level Waste (Near Surface) Disposal**

There are currently three active, licensed commercial LLW disposal sites; however, none can accept GTCC LLW. A license application for a fourth facility is pending:

- EnergySolutions/Chem-Nuclear, formerly GTS-Duratek (Barnwell, South Carolina) - As of July 2008, access is limited to LLW generators within three states composing the Atlantic Compact (South Carolina, Connecticut, and New Jersey). Barnwell disposes of Class A, B and C LLW.
- U.S. Ecology (on DOE's Hanford Site near Richland, Washington) - restricted access to only the Northwest and Rocky Mountain Compacts. U.S. Ecology disposes of Class A, B and C LLW.
- EnergySolutions, formerly Envirocare of Utah (Clive, Utah) - accepts Class A LLW and mixed LLW for LLW generators not limited or bound by compact rules. See Section H.1 for additional information.
- A license application is under review by the State of Texas for a new commercial LLW disposal site at Waste Control Specialists near Andrews, Texas. The proposed site includes a facility to dispose of LLW for the Texas compact and a facility to dispose of Federal mixed LLW and LLW.
- Commercial LLW sites now closed are: Beatty, Nevada (closed 1993); Maxey Flats, Kentucky (closed 1977); Sheffield, Illinois (closed 1978), and West Valley, New York (closed 1975).

Table D-4 provides a breakdown of LLW commercially disposed in 2007, a representative year.<sup>42</sup> About 56 percent of the LLW commercially disposed in 2007 is from government sources, including Federal, state and local governments. No commercial LLW is disposed in DOE (government) facilities, but DOE does dispose of

---

<sup>42</sup> Source: Manifest Information Management System database, DOE December 2007, see <http://mims.apps.em.doe/mims.asp>

LLW at both government and commercial facilities, when economical. Industry, including waste brokers and processors, accounts for 22 percent of the volume of LLW disposed commercially. Nuclear power plant operations generate 20 percent of the volume of waste disposed commercially, and about 1.5 percent is from academic and medical sources.

Over 99 percent of the LLW volume disposed of at commercial sites was Class A LLW, most of which was disposed of at the Clive, Utah site, with the remaining volume split between the Barnwell, South Carolina, and U.S. Ecology, Richland, Washington, sites. All of Class B LLW and over 99 percent of Class C waste was disposed at the Barnwell site, with the remainder disposed at Richland.

Source	Class A	Class B	Class C	Total
Academic	1,565	0	1	1,566
Government (from DOE)	72,500	0	0	72,500
Government (non-DOE)	6,745	3	2	6,750
Industry	33,281	11	11	33,303
Medical	838	0	2	840
Utility	30,596	322	396	31,314
Government Mixed LLW (from DOE)	5,190	0	0	5,190
All Other	802	0	0	802
<b>Total</b>	<b>151,517</b>	<b>336</b>	<b>412</b>	<b>152,265</b>

DOE operates disposal facilities for LLW at: Hanford, Washington; Idaho National Laboratory, Idaho; Los Alamos National Laboratory (LANL), New Mexico; Nevada Test Site, Nevada; and Savannah River Site, South Carolina. DOE also operates LLW disposal facilities for waste from cleanup projects (generally large volumes with low concentrations) at Hanford, Idaho National Laboratory, and Oak Ridge, Tennessee.

There are also closed disposal facilities managed by DOE. The Greater Confinement Disposal Facility (boreholes) was used to dispose of certain TRU and other defense waste at the Nevada Test Site until 1989. There are closed burial grounds for LLW used decades ago for disposal of wastes resulting from defense activities, e.g., at Hanford, Oak Ridge, and Savannah River. Hydrofracture was once used at Oak Ridge, Tennessee, for disposal of waste in slate formations beneath the site.

In addition to the LLW facilities discussed above, U.S. waste generators also may use hazardous waste disposal facilities for waste with very low levels of radioactive constituents. These facilities are designed to isolate hazardous waste substances from the environment, but are also effective in isolating radioactive constituents and may offer cost and efficiency benefits. Some sites are used for disposal of naturally occurring radioactive materials, and therefore already have procedures and features for ensuring safety of disposal of low activity radioactive waste. Waste originating in the nuclear fuel cycle, if appropriate, is disposed in these facilities under specifically authorized limits, after a safety analysis is performed.

There are no current uniform selection criteria for authorizing disposal of LLW at hazardous waste sites; this is done on a waste-and site-specific basis. Information on LLW disposal at sites other than LLW sites can be found at: DOE Order 5400.5 for DOE owned or generated waste and 10 CFR 20.2002 for waste generated by NRC-licensed activities. In general the selection criteria for disposal of waste with very low levels of radioactive constituents are for specific wastes, which are often large quantities of very low levels of radioactivity (such as slightly contaminated soil) -on the order of 10  $\mu$ Sv per year. Information about hazardous waste disposal sites can be found at 40 CFR Parts 264-268. These requirements include engineered barriers (such as liners), and the waste itself must be treated to meet land disposal restrictions.

### **D.2.2.3 Uranium Mill Tailings Disposal**

Section B.4.4 describes uranium recovery in the United States. Waste forms are classified either as residual radioactive material or 11e.(2) byproduct material, depending on the status of the facility when the Uranium Mill Tailings Radiation Control Act (UMTRCA) was passed in 1978. UMTRCA Title I applies to facilities that were closed or abandoned prior to 1978. Waste material at these sites is referred to as residual radioactive material. Activities at Title I sites were largely focused on decommissioning and cleanup of residual radioactive material. UMTRCA Title II applies to sites licensed in or after 1978. The Atomic Energy Act of 1954 (AEA) identifies 11e.(2) byproduct material as "...the tailings or wastes produced by the extraction or concentration of uranium or thorium from any ore processed primarily for its source material content," and adds "...including discrete surface wastes resulting from uranium solution extraction processes." The range of activities at Title II sites includes siting, design, operation, and ultimately, reclamation of the site. The location of conventional mills can be selected to optimize features of the site. For example, the selection of a conventional mill site is not limited to proximity to any particular ore body or mine. It can be located in a remote area where the population density is relatively low to minimize exposure to the public. However, the site selection for siting an in situ leach (ISL) facilities is dependent on proximity to an ore body.

#### **D.2.2.3.1 UMTRCA Title I Mill Tailings Sites**

The Uranium Mill Tailings Radiation Control Act of 1978 required DOE to complete surface remediation and ground water cleanup at inactive uranium milling sites and contaminated vicinity properties where uranium was processed solely for sale to the Federal government and not licensed in 1978. Waste at these sites is referred to as residual radioactive material. Waste from some sites was combined, and are in now under long-term surveillance. Title I sites generally consist of a disposal cell, filled with residual radioactive material, and covered with an engineered barrier to protect public health and the environment. These piles range in size from 86,000 to 10.8 million metric tons. Annual site inspections are performed as part of the long-term surveillance program. All inactive sites are located in western states, except a site at Canonsburg, Pennsylvania, and an associated property at Burrell, Pennsylvania. The Cheney Disposal Cell containing the residual radioactive material removed from the former Grand Junction Climax site will remain active until 2023 to accept residual radioactive material from other sites.

DOE became a NRC licensee in 1993 under the general license provisions at 10 CFR 40.27. The covered Title I sites are listed in Annex D-3A.

### **D.2.2.3.2 UMRCA Title II Licensed Uranium Recovery Facilities/Mill Tailings Sites**

NRC requires licensees to meet regulations compatible with EPA standards in 40 CFR Part 192 for remediating uranium and thorium milling sites after processing operations have permanently ceased. This includes requirements for long-term stability of byproduct material disposal piles, radon emissions control, water quality protection and cleanup, and remediation of land and buildings.

Byproduct material generated at a Title II site is typically disposed of in a constructed impoundment designed to meet criteria in 10 CFR Part 40, Appendix A (or compatible state regulations). These criteria include requirements for siting and designing the impoundment, operation, maintenance, cover performance, and decommissioning. An important component of these criteria is financial surety for decommissioning, reclamation, and long-term surveillance. Criterion 2 in Appendix A of 10 CFR Part 40 requires byproduct material generated at ISL facilities be disposed of at a constructed impoundment at a conventional uranium mill. As a result, there are no permanent disposal options at the Title II ISL facilities.

There are 41 UMRCA Title II licensed facilities consisting of conventional uranium and thorium mills, ISL facilities, heap leach facilities, and one conversion facility. A total of 21 of these facilities are licensed by NRC, and are located in Nebraska, New Mexico, Oklahoma, South Dakota, Washington and Wyoming. The remaining sites are located in Agreement States. There are five Agreement States (Colorado, Illinois, Texas, Utah, and Washington) licensing AEA Section 11e.(2) byproduct material. Annex D-3A lists both – NRC and Agreement State – regulated uranium recovery facilities.

Two conventional mill site licenses<sup>43</sup> have been terminated in the past three years, and the reclaimed tailings areas transferred to DOE for long-term care under the general license provisions of 10 CFR 40.28. NRC is required to determine applicable standards and requirements have been met before termination of the licenses at sites located in Agreement States.

A separate 11e.(2) waste disposal facility, operated by EnergySolutions at Clive, Utah, was licensed as a commercial facility in November 1993 to receive and dispose of 11e.(2) byproduct material, including radioactive waste from conventional and other milling operations. This license is regulated by Utah under Agreement State authority. The site also has disposal cells licensed by Utah for disposal of low-level radioactive waste and mixed waste. The Energy-Solutions facility was never an active uranium recovery site. It is listed under the Radioactive Waste Management Facilities (Annex D-2).

Another disposal facility for byproduct material has been licensed at the Waste Control Specialists facility in Andrews County, Texas. This facility is currently storing DOE byproduct material from DOE's Fernald, Ohio site awaiting disposition. A license was issued on May 29, 2008. This facility is also listed under the Radioactive Waste Management Facilities (Annex D-2).

---

<sup>43</sup> The 2 mills were WNI Sherwood in the State of Washington and Shirley Basin in the State of Wyoming; refer to Annex D-3A for details.



#### D.2.2.4 Mine Overburden Remediation

The AEA does not identify uranium mining overburden as radioactive material to be controlled, and NRC and DOE do not regulate the disposition of conventional mining wastes as part of the nuclear fuel cycle. EPA, however, has authority, under a variety of legal statutes, for radiation protection from NORM and technologically enhanced NORM (TENORM), including their hazardous and toxic impacts. This authority is frequently extended to individual states, or Federal land management agencies, when regulating the environmental impacts under clean water and clean air legislation, as well as having a general authority to address any mining activity having detrimental effects on humans and habitats. Once uranium mining product is beneficiated or is brought into the milling circuit, including production from *in situ* leach operations, then NRC and its Agreement States regulate its possession, use, transport, etc.

Mine overburden is not classified as radioactive waste requiring restricted disposal, but an estimate of mine overburden is provided at the request of other Contracting Parties to the Joint Convention.<sup>44</sup> The uranium mining industry began in the 1940s to produce uranium for use in weapons, and later for nuclear fuel fabrication. Although there are about 4,000 mines with documented production, a database compiled by EPA with information from other Federal, state, and tribal agencies, includes 15,000 mine locations, mostly 14 western states.<sup>45</sup> Most of locations are found in Colorado, Utah, New Mexico, Arizona, and Wyoming, with about 75 percent of those on Federal and tribal lands. The majority of these sites were conventional (open pit and underground) mines. With the drop in market price of uranium beginning in the 1980s U.S. producers turned to *in situ* leaching operations as a principal means of extracting uranium from ore bodies. There were eleven uranium mines operating in 2006 according to DOE's Energy Information Administration.<sup>46</sup>

The number of operating mines of all kinds, however, may increase because of higher world uranium prices and decreasing supply in the United States.

Mining of uranium ores by surface and underground methods produces large amounts of radioactive waste material classified as NORM or TENORM, including overburden, unreclaimed sub economic ores (protore),<sup>47</sup> "barren" rock, and drill cuttings. The volume of waste produced by surface, open-pit mining is a factor of approximately 45 times greater than for underground mining, based on their respective averages. Thus, the amount of overburden generated from open-pit mines far exceeds underground mine overburden. The U.S. Geological Survey in an estimate for EPA, found the amount of waste rock generated by approximately 4,000 conventional mines in their data files ranged from one billion to nine billion metric tons of waste, with a likely estimate of three billion metric

---

<sup>44</sup> Unless otherwise noted, this information can be found at <http://www.epa.gov/radiation/tenorm/uranium.html>

<sup>45</sup> U.S. Environmental Protection Agency, *Uranium Location Database Compilation*, EPA 402-R-05-009, August 2006.

<sup>46</sup> U.S. Energy Information Administration, 2005. "Domestic Uranium Production Report" (2003-2004), U. S. Uranium Mine Production and Number of Mines and Sources, 2003-2004. <http://www.eia.doe.gov/cneaf/nuclear/dupr/umine.html>

<sup>47</sup> Protore is material containing uranium that cannot be produced at a profit under existing conditions but may become profitable with technological advances or price increases; mineralized material too low in concentration to constitute ore, but from which ore may be formed through secondary enrichment.

tons.<sup>48</sup> Given the larger number of mine locations identified by EPA, the amount of waste rock is likely to be higher.

Studies from mine reclamation assessments show material identified as “waste” or “overburden” varies widely in <sup>226</sup>Ra activity, but for most waste piles dominated by overburden material, measurements higher than 0.74 Bq/g (20 pCi/g) are unusual. Protore, on the other hand, can be considerably higher in <sup>226</sup>Ra activity, with most material in the range of 1.11–22.2 Bq/g (30–600 pCi/g). Radon measurements in some abandoned mines where mechanical ventilation has ceased are quite high, and pose risks for prolonged human exposure. Field measurements show average radon flux rates vary from about 0.07–2.22 Bq/m<sup>2</sup>s (2–60 pCi/m<sup>2</sup>s) for overburden materials, to greater than 7.4 Bq/m<sup>2</sup>s (a few hundred pCi/m<sup>2</sup>s) for low-grade ore materials. The broad range of radon flux rates is due in part to varying <sup>226</sup>Ra concentrations (the parent radionuclide) found in low-grade ores at times disposed of with overburden. Gamma exposure rates for overburden materials range from 20 µR/hr to 300 µR/hr (0.005 to 0.077 µC/kg-hr), with an average value of perhaps 50 µR/hr (0.013 µC/kg-hr), including background. Protore ranges from 80 to 1,250 µR/hr (0.021 to 0.323 µC/kg-hr), with an average value estimated at 350 µR/hr (0.090 µC/kg-hr).

Programs such as the Abandoned Mine Land Program and DOE Uranium Mill Tailings Remedial Action Project focused on restoration of legacy mining and milling sites during the last 50 years. Many individual states and tribes also have reclaimed mine sites. These programs were not limited to uranium, but included other conventional mining operations, such as coal and metals. There are no reliable estimates of the total number of abandoned uranium mines that have been reclaimed. Although most areas where uranium mining has occurred are remote and arid, a principal EPA concern is the recycling of uranium mine waste for other uses, including residential construction materials.

EPA issued a revised report examining the occurrence of uranium in its natural settings in the United States, its industrial uses, and the methods used over the last century to extract it from ore deposits. This report also explores the nature of solid and liquid wastes generated by extraction methods, and various reclamation and remediation methods to environmentally restore extraction sites. A second volume has been prepared to examine, in a general way, the potential radiogenic cancer risks from abandoned uranium mines, as well as their environmental and geographical issues.<sup>49</sup>

### **D.3 Nuclear Facility Decommissioning**

Table D-5 summarizes ongoing U.S. decommissioning activities within the Joint Convention. More information is provided in the following subsections corresponding to each of the entries in Table D-5.

---

<sup>48</sup> *Technologically Enhanced Naturally Occurring Radioactive Materials from Uranium Mining; Volume 1: Mining and Reclamation Background*; EPA 402-R-05-007; Revision June 2007. See <http://www.epa.gov/radiation/tenorm/pubs.html#402-r-05-007>

<sup>49</sup> *Technologically Enhanced Naturally Occurring Radioactive Materials from Uranium Mining; Volume 1: Mining and Reclamation Background*; EPA 402-R-05-007; June 2007. Volume 2, *Investigation of Potential Health, Geographic, and Environmental Issues of Abandoned Uranium Mines*, EPA 402-R-05-008, April 2008. Volumes 1 and 2 may be found at <http://www.epa.gov/radiation/tenorm/pubs.html#402-r-05-007>

Table D-5 Summary of Decommissioning Activities in Progress		
Sector	Type	Number
Government	DOE Nuclear/Radioactive Facilities for which Decommissioning is Ongoing or Pending	912
Government/Commercial	Formerly Utilized Sites Remedial Action Program Sites (FUSRAP)	32
	Decommissioning Materials Sites by NRC	14
	Decommissioning Material Sites in NRC Agreement States	48
Commercial	Nuclear Power Plants	14
	Other Non-Power Reactor Facilities	10
	Uranium Recovery Facilities	11

### D.3.1 DOE Sites with Decommissioning/Remediation Projects

The United States has a legacy of radioactive waste from past government activities spanning five decades. A total of 108 sites covering more than 800,000 hectares (two million acres) of land are used by the U.S. Government for nuclear research and development and nuclear weapons production activities. Most of the land at these sites is not contaminated. Within the boundaries of these sites are numerous radiological-controlled areas with thousands of individual facilities, encompassing 10,500 discrete contaminated locations (“release sites”). Over 6,500 of these release sites have been cleaned up. Full remediation is complete at 85 of 108 DOE sites, and 435 nuclear or radiological facilities are decommissioned.

The U.S. Government continues to safeguard its nuclear materials, dispose of waste, remediate extensive surface and ground water contamination, and deactivate and decommission thousands of excess contaminated facilities. The Fernald Environmental Management Project, Fernald, Ohio, a former defense uranium processing plant, was completed in 2006, including closure of an on-site waste disposal cell. Other sites completed since the last report are:

- Ashtabula, Ohio;
- Columbus Environmental Management Project – West Jefferson, Ohio; and
- Lawrence Berkeley Laboratory, California.

Completing cleanup of at least four more sites are scheduled before the Third Review Meeting. Annex D-4 shows a summary of the remaining nuclear/radioactive facility decommissioning projects, and a summary of remaining DOE remediation projects. Some of the large decommissioning projects now in progress are:

- Brookhaven Graphite Research Reactor;
- Plutonium Finishing Plant at the Hanford Site;
- Fast Flux Test Facility at the Hanford Site;
- East Tennessee Technology Park (formerly the Oak Ridge Gaseous Diffusion Plant); and
- Alpha-4 Building at Oak Ridge Y-12 Complex.

### D.3.2 Formerly Utilized Sites Remedial Action Program

Work was performed at sites throughout the United States during the 1940s, 1950s, and 1960s as part of the Nation's early atomic energy program. Some sites' activities can be traced back as far as World War II and the Manhattan Engineering District (MED). Other sites were involved in peacetime activities under the Atomic Energy Commission (AEC). Most sites contaminated during the early atomic energy program were cleaned up under the guidelines in effect at the time. Those cleanup guidelines were generally not as strict as today's, so trace amounts of radioactive materials remained at some of the sites. Contamination was then spread to other locations, either by demolition of buildings, intentional movement of materials, or by nature.

DOE established the Formerly Utilized Sites Remedial Action Program (FUSRAP) in 1974 to study these sites and take appropriate cleanup action. When contamination is suspected at a site, old records are reviewed and the site is surveyed. Additional cleanup is authorized under FUSRAP if contamination connected to a MED or AEC activity is found. The Congress also added some sites to FUSRAP with industrial contamination similar to MED or AEC activities. These FUSRAP sites are distinct from the formerly licensed facilities, which are addressed in Section H.1.2.

The Energy and Water Development Appropriations Act for Fiscal Year 1998, P.L. 105-62 (October 13, 1997) transferred responsibility for the administration and execution of FUSRAP from DOE to the U.S. Army Corps of Engineers (COE). The COE contract strategy concentrates on individual site-specific remediation contracts. The COE pursues more efficient remedial actions through the use of performance-based specifications, using fixed-price and cost-type contracts. Sites are returned to DOE for long-term stewardship when remediation is completed.

DOE established the Office of Legacy Management in 2003 to manage sites and activities where missions have been completed and sites closed. This Office has responsibility for all FUSRAP sites remediated by DOE and those transferred back to DOE by COE. Extensive FUSRAP-related information (including information on specific sites) is available on the Legacy Management web page <http://www.lm.doe.gov>. Legacy Management has also developed the Considered Sites Database (CSD)<sup>50</sup> to provide public information documenting site eligibility and characterization, remediation, verification, and certification for all FUSRAP sites.

The contaminants at FUSRAP sites are primarily low levels of uranium, thorium, and radium, with their associated decay products. Materials containing low levels of radioactive residues are excavated, packaged, and transported for disposal at licensed commercial disposal sites, or to hazardous waste landfills, as appropriate. Annex D-5 lists FUSRAP sites with ongoing remediation. In some cases, the FUSRAP sites are also considered as complex material decommissioning sites, and are listed in Annex D-6.

---

<sup>50</sup> CSD is available at <http://csd.gjo.doe.gov>

### **D.3.3 Complex Materials Sites Decommissioning (NRC)**

NRC has taken a comprehensive approach to its decommissioning program to achieve better effectiveness. See Section F.6.1 for additional information. NRC developed a Site Decommissioning Management Plan (SDMP) in 1990 for timely cleanup of 49 unusual and difficult sites, particularly those with high soil contamination or with old, contaminated buildings. NRC eliminated the SDMP designation in 1997, and now manages the SDMP sites as “complex sites” under its broader decommissioning program. This comprehensive decommissioning program uses a dose-based approach for regulating decommissioning activities, and includes routine decommissioning sites, formerly licensed sites, SDMP sites, non-routine/complex sites, fuel cycle sites, and test/research and power reactors. Remediating these sites is now managed more effectively as part of this larger program.

As of September 30, 2008, 14 complex decommissioning materials facilities are undergoing decommissioning under NRC jurisdiction. Annex D-6 provides a list of these 14 “complex sites” subject to decommissioning. Between October 2005 and October 2008, NRC terminated decommissioning status for nineteen “complex sites”: Sites terminated were: (1) Cabot Performance Materials, (2) Department of the Army-Ft. Belvoir, (3) Dow Chemical, (4) Eglin Air Force Base, (5) Heritage Minerals, (6) Kaiser Aluminum, (7) Kerr McGee Cushing, (8) Kirtland Air Force Base, (9) S.C. Holdings, (10) Royersford Wastewater Treatment Facility, (11) Pathfinder Atomic Plant, (12) Union Carbide Corporation, (13) Salmon River, (14) Westinghouse-Blairsville, (15) Westinghouse-Churchill, (16) Department of the Army-Ft. McClellan, (17) Engelhard Minerals, (18) Battelle Columbus Laboratories, and (19) Homer Laughlin. Some sites listed in previous reports in this annex have been transferred to State regulatory authorities. NRC is committed to terminating one site each year from the list of complex material sites under decommissioning.

More specific information on the decommissioning status of NRC regulated sites can be found at NRC’s website,<sup>51</sup> including specific status information for each complex site.

#### **D.3.3.1 Complex Decommissioning Sites Regulated by NRC Agreement States**

NRC can under the provisions of the AEA, relinquish regulatory authority to individual states including regulation of decommissioning material sites in those states. A recent example is the regulatory authority for decommissioning complex material sites in the Commonwealth of Pennsylvania. On March 31, 2008, Pennsylvania became an Agreement State, and NRC relinquished its authority over those complex facilities under decommissioning therein. See Section E.2.7.2 for additional information. Annex D-6 also lists those facilities undergoing decommissioning in the Agreement States.

#### **D.3.3.2 Power and Non-Power Reactor Decommissioning**

NRC has regulatory oversight responsibility for decommissioning 14 power reactors as of August 2008. NRC also provides oversight for decommissioning of 10 research and test reactors. Annex D-7 lists these reactors. Currently, 10 research and test reactors have been issued decommissioning orders or amendments by NRC, and one of these has submitted a decommissioning amendment request for approval of a

<sup>51</sup>See <http://www.nrc.gov/about-nrc/regulatory/decommissioning.html>

decommissioning plan, now undergoing staff review. Three research and test reactors are currently in “possession-only” status.

### **D.3.3.3 Other Non-Power Facility Decommissioning**

NRC provides project management and technical review for decommissioning and reclamation of facilities regulated in 10 CFR Part 40, Appendix A [under the Uranium Mill Tailings Radiation Control Act (UMTRCA) Title II]. These licensees include conventional uranium mills, heap leach facilities, and *in situ* leach (ISL) facilities. Annex-D3 shows these sites. Decommissioning activities at conventional uranium mills include mill demolition, groundwater cleanup, soil cleanup, and closure of tailings impoundment. Decommissioning activities at ISL facilities are focused on restoring groundwater quality to pre-operational conditions, soil cleanup, and building demolition.

NRC also provides licensing oversight and decommissioning project management for fuel cycle facilities, including conversion plants, enrichment plants, and fuel manufacturing plants. NRC continues to work closely with the states and EPA to regulate remediation of unused portions of fuel cycle facilities. The only fuel cycle facility undergoing partial decommissioning is the Nuclear Fuels Services (NFS) site in Erwin, Tennessee.

### **D.3.4 EPA Site Remediation**

EPA remediates radiologically contaminated sites using its Comprehensive Environmental Response, Compensation, and Liability Act (CERCLA) authority.<sup>52</sup> The purpose of CERCLA however, is not to address the routine shutdown and decommissioning of facilities. Rather, CERCLA provides a mechanism to address extensively contaminated facilities, inactive or abandoned sites. EPA typically, will evaluate a site’s potential hazard to public health and the environment at the request of government officials or communities. If the hazard is judged to be sufficiently high, the site may be placed on the National Priorities List (NPL). The CERCLA process heavily involves public participation in arriving at a Record of Decision (ROD), laying out the requirements and milestones for the cleanup. EPA’s cleanup guidelines for carcinogenic contaminants including some radionuclides, are aimed at achieving a level of remediation resulting in a lifetime risk to human health between  $10^{-4}$  and  $10^{-6}$ , with  $10^{-6}$  being the ideal. The actual cleanup levels and methods for any particular site depend on a number of criteria, including the future site use, permanence of the selected remedy, and the views of the local community. CERCLA embodies the “polluter pays” principle and gives EPA authority to identify potentially responsible parties who may have contributed to the contamination, negotiate the terms for conducting or contributing cleanup, and enforcing financial judgments. EPA may also conduct emergency removal actions at sites where the situation presents an imminent threat to human health or the environment, even if the site is not on the NPL. Since the passage of CERCLA in 1980, 54 radiologically contaminated sites have been placed on the NPL (out of 1,256 sites). Cleanup has been completed or the selected remedy implemented (e.g., construction of a groundwater treatment system that may operate over a number of years) at 33 of the radiologically contaminated sites. NPL sites have included uranium mines, DOE facilities (e.g., portions of the Fernald site mentioned in Section D.3.1), NRC licensees, and sites being addressed through FUSRAP.

---

<sup>52</sup>See <http://www.epa.gov/superfund>

## E. LEGISLATIVE & REGULATORY SYSTEMS

### E.1 Legislative System

The policy on regulatory control of radioactive waste management in the United States has evolved through a series of laws establishing Federal Government agencies responsible for the safety of radioactive materials as described in Section A. Federal legislation is enacted by Congress and signed into law by the President. U.S. Laws apply to all 50 states and its territories. Legislation on the safety of spent fuel and radioactive waste can be traced back for five decades. Table E-1 identifies key U.S. Laws governing radioactive waste management.

Congress enacted the Atomic Energy Act (AEA) of 1954, for the first time permitting the wide peaceful use of atomic energy. Three types of commercial nuclear materials are regulated:

- Special nuclear material - uranium-233 or uranium-235, enriched uranium, or plutonium;
- Source material - natural uranium or thorium, or depleted uranium not suitable for use as reactor fuel; and
- Byproduct material – See Section B.2.3.

The National Environmental Policy Act (NEPA), enacted in 1969, established a national policy for the environment and the Council on Environmental Quality. EPA was subsequently created in 1970 by Presidential Executive Order, and gave AEA authority for setting generally applicable standards for radioactivity in the environment outside the boundaries of AEC-owned or licensed facilities. A separate statute, the Waste Isolation Pilot Plant Land Withdrawal Act, as amended, provides EPA authority to periodically certify that WIPP meets EPA generally applicable standards.<sup>53</sup> EPA also has responsibility for regulating and enforcing the levels of radioactivity in air emissions and in drinking water under the Clean Air Act and the Safe Drinking Water Act.

Congress passed the Energy Reorganization Act in 1974, separating the AEC into NRC and Energy Research and Development Administration (ERDA), predecessor of DOE. Additional legislation further defined NRC and DOE roles and introduced a role for states through the Low-Level Radioactive Waste Policy Act of 1980 (LLRWPA), and the Low-Level Radioactive Waste Policy Amendments Act of 1985 (LLRWPA). This legislation assigned responsibility to the states, rather than the U.S. Government, to provide disposal capacity for commercial Class A, B and C LLW.

A.	Introduction
B.	Policies & Practices <ul style="list-style-type: none"><li>▪ Article 32, paragraph 1</li></ul>
C.	Scope of Application <ul style="list-style-type: none"><li>▪ Article 3.</li></ul>
D.	Inventories & Lists <ul style="list-style-type: none"><li>▪ Article 32, paragraph 2</li></ul>
E.	<b>Legislative &amp; Regulatory Systems</b> <ul style="list-style-type: none"><li>▪ Article 18. Implementing Measures</li><li>▪ Article 19. Legislative &amp; Regulatory Framework</li><li>▪ Article 20. Regulatory Body</li></ul>
F.	General Safety Provisions <ul style="list-style-type: none"><li>▪ Article 21. Responsibility of License Holder</li><li>▪ Article 22. Human &amp; Financial Resources</li><li>▪ Article 23. Quality Assurance</li><li>▪ Article 24. Operational Radiation Protection</li><li>▪ Article 25. Emergency Preparedness</li><li>▪ Article 26. Decommissioning</li></ul>
G.	Safety of Spent Fuel Management <ul style="list-style-type: none"><li>▪ Article 4. General Safety Requirements</li><li>▪ Article 5. Existing Facilities</li><li>▪ Article 6. Siting of Proposed Facilities</li><li>▪ Article 7. Design &amp; Construction of Facilities</li><li>▪ Article 8. Facility Safety Assessment</li><li>▪ Article 9. Facility Operation</li><li>▪ Article 10. Spent Fuel Disposal</li></ul>
H.	Safety of Radioactive Waste Management <ul style="list-style-type: none"><li>▪ Article 11. General Safety Requirements</li><li>▪ Article 12. Existing Facilities &amp; Past Practices</li><li>▪ Article 13. Siting of Proposed Facilities</li><li>▪ Article 14. Design &amp; Construction of Facilities</li><li>▪ Article 15. Facility Safety Assessment</li><li>▪ Article 16. Facility Operation</li><li>▪ Article 17. Institutional Measures After Closure</li></ul>
I.	Transboundary Movement <ul style="list-style-type: none"><li>▪ Article 27.</li></ul>
J.	Disused Sealed Sources <ul style="list-style-type: none"><li>▪ Article 28.</li></ul>
K.	Planned Activities to Improve Safety

<sup>53</sup> 40 CFR Part 191

Table E-1 Key U.S. Laws Governing Radioactive Waste Management

**Atomic Energy Act of 1954**, as amended, established the Atomic Energy Commission, the predecessor to NRC and DOE, with Federal responsibility to regulate the commercial use of nuclear materials including the regulation of civilian nuclear reactors. Under Reorganization Plan No. 3 of 1970, which created EPA, authority to establish generally applicable environmental standards was transferred to EPA along with authority to provide Federal guidance on radiation protection matters affecting public health.

**The Price-Anderson Act (1957)** was enacted to encourage development of the nuclear industry and ensure prompt and equitable compensation in the event of a nuclear incident. The Act provides a system of financial protection for persons who may be liable for and persons who may be injured by such an incident.

**National Environmental Policy Act (NEPA) of 1969**, as amended, requires Federal agencies to consider environmental values and factors in agency planning and decision-making. Full compliance with the letter and spirit of the NEPA, the U.S. national charter for protection of the environment, is an essential priority for EPA, Council on Environmental Quality, DOE and NRC.

**The Marine Protection, Research, and Sanctuaries Act (MPRSA) of 1972**, also known as the Ocean Dumping Act, prohibits the dumping of material into the ocean unreasonably degrading or endangering human health or the marine environment.

**Energy Reorganization Act of 1974**, as amended, abolished the AEC and established NRC and ERDA—the predecessor of DOE.

**Department of Energy Organization Act (1977)** brought together most of the Government's energy programs, as well as defense responsibilities that included the design, construction, and testing of nuclear weapons into the new Department of Energy. DOE was activated on October 1, 1977, assuming the responsibilities of the Federal Energy Administration, the Energy Research and Development Administration, the Federal Power Commission, and parts and programs of several other Federal agencies.

**Uranium Mill Tailings and Radiation Control Act (UMTRCA) of 1978**, as amended, vested EPA with overall responsibility for establishing health and environmental cleanup standards for uranium milling sites and contaminated vicinity properties, NRC with responsibility for licensing and regulating uranium production and related activities, including decommissioning, and DOE with responsibility for long-term monitoring of the decommissioned sites.

**Comprehensive Environmental Response, Compensation, and Liability Act of 1980 (CERCLA)** as amended, also known as Superfund, provided EPA with authority to address abandoned hazardous waste sites and outlined the process to be followed in identifying and remediating sites, including determination of cleanup values and pursuit of financial judgments against parties deemed to have contributed to the contamination. CERCLA includes radionuclides as a hazardous substance.

**Low-Level Radioactive Waste Policy Act of 1980 and the Low-Level Radioactive Waste Policy Amendments Act of 1985 (LLRWPA)** gave the states – rather than the Federal Government – responsibility to provide disposal capacity for commercial Class A, B and C LLW; authorized the formation of regional compacts (groups of states) for the safe disposal of such LLW; and allowed compacts to decide whether to exclude waste generated outside the compact. The Act also provided a system of milestones, incentives, and penalties to encourage states and regional compacts to be responsible for their own LLW.

**National Security and Military Applications of Nuclear Energy Authorization Act of 1980**  
Section 213 (a) of the Act authorizes WIPP “for the express purpose of providing a research and development facility to demonstrate the safe disposal of radioactive wastes resulting from defense activities and programs of the United States exempted from regulation by the U.S. Nuclear Regulatory Commission.”

**West Valley Demonstration Project Act of 1980** authorized DOE to conduct a technology demonstration project for solidifying HLW, disposing of waste created by the solidification, and decommissioning the facilities used in the process. The Act required DOE to enter into an agreement with the State of New York for carrying out the Project.



Table E-1 Key U.S. Laws Governing Radioactive Waste Management

**Nuclear Waste Policy Act of 1982 (NWSA) and the Nuclear Waste Policy Amendments Act of 1987 (NWPAA)** provide for the siting, construction, and operating of a deep geologic repository for disposing of spent fuel and HLW. Among other things, these laws established the framework for site approval by the President and Congress and for licensing by NRC of the construction, operation and closure of the repository at the site.

**Waste Isolation Pilot Plant Land Withdrawal Act (WIPP LWA) of 1992**, as amended, withdraws land from the public domain for operation of the WIPP. Defines operational limitations and the role of the U.S. Environmental Protection Agency and the U.S. Mine Safety and Health Administration. Exempts TRU mixed waste destined for disposal at WIPP from treatment requirements and land disposal prohibitions under the Solid Waste Disposal Act. The Act provides for EPA continuing oversight role at WIPP, including recertification that WIPP meets EPA standards.

**Energy Policy Act (EnPA) of 1992** mandated site-specific public health and safety standards and site specific licensing requirements for the proposed repository at Yucca Mountain, Nevada.

**Energy Policy Act of 2005 (EPAct05)** Sets forth an energy and development program and includes specific provisions addressing, among other things, disposal of GTCC LLW (including certain sealed sources), NORM, and accelerator-produced waste.

Congress amended NWSA (Table E-1) through the NWPAA in 1987 to:

- Direct DOE to study (characterize) only the Yucca Mountain site;
- Create a Nuclear Waste Technical Review Board (NWTRB) as an independent technical review body;
- Require a report to Congress between 2007 and 2010 on the need for a second repository; and
- Establish the role of NRC during the site characterization process.

The Energy Policy Act (EnPA) of 1992 mandated a new and different process for EPA to develop HLW disposal standards for a repository at Yucca Mountain. Congress directed the National Academy of Sciences (NAS) to evaluate the scientific basis for a Yucca Mountain standard, and provide EPA with recommendations on reasonable standards to protect public health and safety. The NAS is a private, nonprofit institution providing science, technology and health policy advice under a Congressional charter. The NAS established a Board on Radioactive Waste Management (now part of the new Nuclear and Radiation Studies Board) focusing on waste management and disposal. The EnPA directed EPA to promulgate new public health and safety standards based on and consistent with, the NAS findings and recommendations. EnPA directed NRC to modify its technical requirements to conform to the new EPA standards.

EPA issued the final rule for Public Health and Environmental Radiation Protection Standards for Yucca Mountain in 40 CFR Part 197, on June 13, 2001. That rule established, among other things, a 0.15 mSv/a (15 mrem/yr) standard for the 10,000 year period after closure of the repository. In July 2004, a Federal Court vacated the 10,000-year compliance period as inconsistent with the recommendations of the NAS to assess compliance at the time of peak risk (See Section E.2.1.2). On September 30, 2008, EPA issued an amended rule that maintains the 0.15 mSv/a (15 mrem/yr) standard for the first 10,000 years and establishes a 1 mSv/a (100 mrem/yr) standard for the period after the initial 10,000 years out to one million years.

Among other responsibilities, NRC's role is to regulate the construction, operation and closure of the repository at the Yucca mountain site. NRC finalized its licensing criteria

and published 10 CFR Part 63 on November 2, 2001, incorporating EPA's June 2001 standards, which were subsequently vacated by the D.C. Circuit. NRC will make corresponding changes as necessary to 10 CFR Part 63 to make its requirements consistent with EPA's amended standards. The licensing process includes an adjudicatory hearing, which results in a determination by NRC on whether to issue a license authorizing construction of a repository at the proposed Yucca Mountain site. Prior to DOE starting operations, NRC would need to issue a license amendment authorizing DOE to receive and possess waste at the repository.

DOE is responsible for the development of a geologic repository for the disposal of spent fuel and HLW (See Section D.1.2). The NWPA, as amended, established a process for the identification, characterization and approval of a site for a permanent geologic repository and for its licensing by NRC. In 2002, the Secretary of Energy concluded that the Yucca Mountain site was suitable for development as a repository. In accordance with the process defined in the NWPA, the Secretary formally recommended the Yucca Mountain site to the President on February 14, 2002. The President recommended the site to the Congress, and Congress subsequently passed a joint resolution that approved the site at Yucca Mountain, Nevada, for a repository. The site designation took effect when the President signed the repository siting joint resolution (Public Law No: 107-200) on July 23, 2002. On June 3, 2008, DOE submitted a license application to the NRC to construct the proposed repository at Yucca Mountain. On September 8, 2008, NRC formally docketed the Yucca Mountain license application, which triggered a three-year deadline, with a possible one-year extension, for NRC to decide whether or not to grant a construction authorization to DOE.

The NWPA requires DOE to report to the President and Congress after January 1, 2007, but not later than January 1, 2010, on the need for a second repository.

## **E.2 Regulatory System**

The regulatory system for spent fuel and radioactive waste management in the United States involves several agencies: NRC, regulating the commercial nuclear sector; EPA, establishing environmental standards; and DOE, regulating its government programs. Some NRC regulatory authority – excluding spent fuel, special nuclear material sufficient to form a critical mass, and HLW – can be relinquished to the 50 states of the United States (including territories, Puerto Rico, and the District of Columbia) under its Agreement State Program. This authority includes regulating commercial LLW disposal sites and uranium mill tailings sites, and regulatory authority over disposal of mill tailings. Some states also have regulatory authority delegated to them by EPA, such as for discharges from some industrial or mining practices. See Section E.2.7 for additional information.

The general regulations for the three Federal Agencies responsible for radioactive waste regulation are contained in Title 10 (for NRC and DOE) and Title 40 (for EPA) of the U.S. Code of Federal Regulations (CFR). U.S. Government regulations are developed through an open process, including the opportunity for public comment. New regulations are published in the *Federal Register*, in proposed or final forms. Specific regulations for

each Agency is in Table E-2. Copies of these regulations are available in print and electronically<sup>54</sup>.

DOE orders are internal directives which function similar to regulations for DOE and DOE contractor activities. Compliance with orders is mandatory for DOE and is enforced through contract provisions for DOE contractors.

The separation between EPA's standard-setting function and NRC's implementing function reflects a nearly 40-year-old Congressional policy of centralizing environmental standard setting in a single agency. When EPA was established, it was given environmental authorities scattered among several older agencies, including NRC's predecessor, the (AEC). There are advantages to having an agency both set and implement standards, and NRC does so in many subject areas, most especially reactor design and operation. Nonetheless, there are also advantages to having environmental standards set on a national basis by a single agency whose jurisdiction is wide enough to permit the agency to rank risks from many sources, including nuclear.

Table E-2 Spent Fuel and Radioactive Waste Management Regulations
<p><b><u>U.S. Nuclear Regulatory Commission</u></b></p> <ul style="list-style-type: none"> <li>• 10 CFR Part 20, <i>Standards for protection against radiation</i></li> <li>• 10 CFR Part 30, <i>Rules of general applicability to domestic licensing of byproduct material</i></li> <li>• 10 CFR Part 40, <i>Domestic Licensing of Source Material</i></li> <li>• 10 CFR Part 51, <i>Environmental protection regulations for domestic licensing and related regulatory functions</i></li> <li>• 10 CFR Part 60, <i>Disposal of High-Level Radioactive Wastes in Geologic Repositories</i></li> <li>• 10 CFR Part 61, <i>Licensing Requirements for Land Disposal of Radioactive Waste</i></li> <li>• 10 CFR Part 62, <i>Criteria and Procedures for Emergency Access to Non-Federal and Regional Low-Level Waste Disposal Facilities</i></li> <li>• 10 CFR Part 63, <i>Disposal of High-Level Radioactive Wastes in a Geologic Repository at Yucca Mountain, Nevada</i></li> <li>• 10 CFR Part 70, <i>Domestic Licensing of Special Nuclear Material</i></li> <li>• 10 CFR Part 71, <i>Packaging and Transportation of Radioactive Material</i></li> <li>• 10 CFR Part 72, <i>Licensing Requirements for the Independent Storage of Spent Nuclear Fuel and High-Level Radioactive Waste</i></li> <li>• 10 CFR Part 110, <i>Export and Import of Nuclear Equipment and Material</i></li> </ul> <p><b><u>U.S. Department of Energy</u></b></p> <ul style="list-style-type: none"> <li>• 10 CFR Part 765, <i>Reimbursement of Costs for Remedial Action at Active Uranium and Thorium Processing Sites</i></li> <li>• 10 CFR Part 766, <i>Uranium Enrichment Decontamination and Decommissioning Fund; Procedures for Special Assessment of Domestic Utilities</i></li> <li>• 10 CFR Part 820, <i>Procedural Rules for DOE Nuclear Facilities</i></li> <li>• 10 CFR Part 830, <i>Nuclear Safety Management</i></li> <li>• 10 CFR Part 835, <i>Occupational Radiation Protection</i></li> <li>• 10 CFR Part 960, <i>General Guidelines for the Recommendation for Sites for Nuclear Waste Repositories</i></li> </ul>

<sup>54</sup>Electronic versions of the Code of Federal Regulations are available on the Internet at: <http://www.gpoaccess.gov/cfr/index.html>

Table E-2 Spent Fuel and Radioactive Waste Management Regulations

- 10 CFR Part 963, *Yucca Mountain Site Suitability Guidelines*
- 10 CFR Part 1021, *National Environmental Policy Act Implementing Procedures*

Although not formal regulations, the following DOE orders are applicable to safety:

- Order 151.1B, *Comprehensive Emergency Management System*
- Order 231.1A, *Environment, Safety, and Health*
- Order 360.1B, *Federal Employee Training*
- Order 414.1C, *Quality Assurance*
- Order 420.1A, *Facility Safety*
- Guide 421.1-2; Guide 423.1-1; DOE Guide 424.1-1, *Implementation Guides for 10 CFR 830*
- Order 425.1C, *Startup and restart of Nuclear Facilities*
- Order 430.1B, *Real Property Asset Management*
- Order 433.1, *Maintenance Management Program*
- Order 435.1, *Radioactive Waste Management*
- Order 440.1A, *Worker Protection Management for DOE Federal and Contractor Employees*
- Order 470.2B, *Independent Oversight and Performance Assurance Program*
- Order 5400.5, *Radiation Protection of the Public and the Environment*
- Order 5480.19A, *Conduct of Operations Requirements for DOE Facilities*
- Order 5480.20A, *Personnel Selection, Qualification, and Training Requirements for DOE Nuclear Facilities*

**U.S. Environmental Protection Agency**

40 CFR Part 61, *National Emission Standards for Hazardous Air Pollutants*

- Subpart B, *Radon from Underground Uranium Mines*
- Subpart H, *Radionuclide Emissions, other than Radon, from DOE Facilities*
- Subpart I, *Radionuclide Emissions from Federal Facilities other than DOE or NRC Licensed Facilities*
- Subpart K, *Radionuclide Emissions from Elemental Phosphorus Plants*
- Subpart Q, *Radon from DOE Facilities*
- Subpart R, *Radon from Phosphogypsum Stacks*
- Subpart T, *Radon from Disposal of Mill Tailings*
- Subpart W, *Radon from Tailings at Operating Mills*

40 CFR Part 191, *Environmental Radiation Protection Standards for Management and Disposal of Spent Nuclear Fuel, High-Level and Transuranic Radioactive Wastes*

40 CFR Part 192, *Health and Environmental Protection Standards for Uranium and Thorium Mill Tailings*

40 CFR Part 194, *Criteria for the Certification and Re-Certification of the Waste Isolation Pilot Plant's (WIPP) Compliance with the 40 CFR Part 191 Disposal Regulations*

40 CFR Part 197, *Public Health and Environmental Radiation Protection Standards for Yucca Mountain, Nevada*

Other Title 40, Code of Federal Regulations relating to radiation protection include:

- Part 141, *National Primary Drinking Water Regulations*

Table E-2 Spent Fuel and Radioactive Waste Management Regulations
<ul style="list-style-type: none"> <li>• Part 147, <i>State Underground Injection Control Programs</i></li> <li>• Part 148, <i>Hazardous Waste Injection Restrictions</i></li> <li>• Part 195, <i>Radon Proficiency Programs</i></li> <li>• Parts 220 and 133, <i>Ocean Dumping</i></li> <li>• Part 300, <i>National Oil and Hazardous Substances Pollution Contingency Plan</i></li> <li>• Part 302, <i>Designation, Reportable Quantities, and Notification</i></li> <li>• Part 440, <i>Ore Mining and Dressing Point Source Category (Uranium, Radium, and Vanadium Ores subcategory)</i></li> </ul>

### E.2.1 U.S. Nuclear Regulatory Commission

NRC is an independent regulatory agency created from the AEC by Congress under the Energy Reorganization Act of 1974 to assure protection of the public health and safety and the environment, and to promote the common defense and security in the civilian use of byproduct, source, and special nuclear materials.

NRC regulates:

- Commercial nuclear power; non-power research, test, and training reactors;
- Fuel cycle facilities; medical, academic, and industrial uses of nuclear materials; and
- Transportation, storage, and disposal of nuclear materials and waste.

NRC regulates manufacture, production, transfer or delivery, receiving, acquisition, ownership, possession, and use of commercial radioactive materials, including the regulation of the associated radioactive waste. NRC regulates waste in three broad classification types as described in Section B: LLW, HLW (spent fuel is classified in the broader context of HLW in NRC regulations), and uranium mill tailings.

Table E-3 lists NRC’s strategic goals and corresponding outcomes to measure results for meeting those goals.

Table E-3 NRC Strategic Goals and Outcomes
<p>NRC’s strategic objective is to enable the use and management of radioactive materials and nuclear fuels for beneficial civilian purposes in a manner that protects public health and safety and the environment, promotes the security of our nation, and provides for excellence in regulatory actions that are open, effective, efficient, realistic, and timely.</p> <p>The strategic goals to meet this objective are:</p> <ul style="list-style-type: none"> <li>• <b>Safety</b> - Ensure adequate protection of public health and safety and the environment; and</li> <li>• <b>Security</b> - Ensure adequate protection in the secure use and management of radioactive materials.</li> </ul> <p>The organizational excellence objectives to support the strategic goals of safety and security are:</p> <ul style="list-style-type: none"> <li>• Openness;</li> <li>• Effectiveness;</li> <li>• Timeliness; and</li> <li>• Operational excellence.</li> </ul>

**Strategic Outcomes** which will serve as metrics for the success or failure in meeting these goals include:

- Prevent the occurrence of any nuclear reactor accidents;
- Prevent the occurrence of any inadvertent criticality events;
- Prevent the occurrence of any acute radiation exposures resulting in fatalities;
- Prevent the occurrence of any releases of radioactive materials that result in significant radiation exposures; and
- Prevent the occurrence of any releases of radioactive materials that cause significant adverse environmental impacts.

Reference: FY 2008-2013 Strategic Plan (NUREG-1614, Vol.4) URL: <http://www.nrc.gov/reading-rm/doc-collections/nuregs/staff/sr1614/v4/>

The following activities are key elements of NRC's regulatory program.

### Regulations and Guidance

- Rulemaking—developing and amending regulations licensees must meet to obtain or retain a license or certificate to use nuclear materials or operate a nuclear facility.
- Guidance Development—developing and revising guidance documents, such as regulatory guides, standard review plans, and the NRC Inspection Manual to guide NRC in implementing regulations and acceptable approaches for licensees to meet regulations. A listing of guidance issued by NRC is provided in
- Annex E-1.
- Generic Communications—sending applicants and licensees information about operational events at other nuclear facilities and/or requests for information from licensees related to operations.
- Standards Development—working with industry standards organizations to develop consensus standards for design, construction, and inspecting nuclear industry systems, equipment, and materials. These standards may be referenced in NRC regulations or guidance.

### Licensing, Decommissioning, and Certification

- Licensing - authorizing an applicant to use or transport nuclear materials, or to operate a nuclear facility (includes new licenses, renewals, amendments, and transfers).
- Decommissioning – removing nuclear facilities from service and reducing residual radioactivity to a level permitting licensing termination.
- Certification - authorizing an applicant to manufacture spent fuel casks and transportation packages for nuclear materials, the design of sealed sources and devices, and authorizing an applicant to operate a gaseous diffusion plant. Certification does not authorize the manufacture of sealed sources and devices. NRC approves the device or source design and issues separate licenses authorizing possession and distribution.

## Oversight

- Inspection - verifying a licensee's activities are properly conducted to ensure safe operations in accordance with NRC regulations and license requirements.
- Enforcement - issuing sanctions to licensees who violate NRC regulations and license conditions.
- Performance Assessment- determining appropriate agency action from reviews of licensee performance documented in inspection reports and performance indicators.
- Allegations- responding to and investigating reports of wrongdoing by NRC licensees, applicants for licenses, licensee's contractors or vendors, or their employees.
- Investigations - investigating wrongdoing by NRC licensees.

NRC conducts licensing and inspection activities for domestic nuclear fuel cycle facilities, uses of nuclear materials, transport of nuclear materials, management and disposal of LLW and HLW, and decontaminating and decommissioning facilities and sites. NRC is also responsible for establishing the technical bases for regulations, and provides information and technical bases for developing acceptance criteria for licensing reviews

An important aspect of NRC's regulatory program is inspection and enforcement. NRC has four regional offices (Region I in King of Prussia, Pennsylvania; Region II in Atlanta, Georgia; Region III in Lisle, Illinois; and Region IV in Arlington, Texas). These offices inspect licensed facilities in their regions, including nuclear waste facilities. NRC's Office of Federal and State Materials and Environmental Management Programs communicates with state and local governments, and tribes, and oversees the Agreement States Program. An Agreement State is a state signing an agreement with NRC allowing the state to regulate use of radioactive material compatible with NRC regulations. There are 35 Agreement States as of April 1, 2008.

### **E.2.1.1 Uranium Recovery Regulation**

NRC is responsible for planning and implementing regulatory programs under Uranium Mill Tailings Radiation Control Act (UMTRCA). Title I (of UMTRCA) involves managing, coordinating, and conducting safety and environmental reviews of remediation activities, and reviewing and concurring in documents for cleanup of abandoned uranium mill tailings sites.

UMTRCA asked EPA to issue generally applicable standards for controlling uranium mill tailings. EPA issued standards for both Title I and Title II sites in 1983. The Title I program established a joint Federal/state funded program for remedial action at abandoned mill tailings sites, with final Federal ownership under NRC license. NRC, under Title I, must evaluate DOE designs and agree DOE actions meet standards set by EPA. EPA issued final Title I UMTRCA groundwater standards in 1995. All surface remedial action was completed in fiscal year 1999. Reviews for the ground water remedial action program for all other Title I sites remain. NRC and DOE have a memorandum of understanding to clarify their roles and responsibilities, e.g., to minimize or eliminate duplication of effort between the two agencies.

UMTRCA Title II involves planning and directing activities for active, licensed uranium recovery facilities, including facility licensing and operation, and mill tailings management and decommissioning. Title II deals with NRC or Agreement States sites. NRC changed its regulations in November 1995 in 10 CFR Part 40, Appendix A, consistent with EPA Title II standards and meeting UMTRCA requirements. NRC has authority under Title II to control radiological and non-radiological hazards, and ensure NRC-licensed and Agreement State-licensed sites meet all standards and requirements during operations, and before termination of licenses. NRC reviews Title II license applicant's plans for operating, reclaiming, decommissioning, and groundwater corrective action; license applications and renewals; license conditions changes; and, annual surety updates. NRC also prepares environmental assessments for some licensing actions. Long-term care of reclaimed tailings sites (by a state or DOE) is licensed by NRC under general licenses at 10 CFR Part 40.27 (for Title I sites) and 40.28 (for Title II sites).

Specific NRC activities under the UMTRCA include:

- Overseeing and program direction for the uranium recovery program;
- Implementing policies and programs; and
- Reviewing uranium recovery licensing and inspection programs for technical adequacy and consistency.

NRC also provides technical assistance to Agreement States on uranium recovery issues and implements an active interface program including consultation with Federal agencies, states, tribes, and other entities to promote understanding of uranium programs and resolving concerns in a timely manner.

### **E.2.1.2 HLW and Spent Fuel Regulation**

Regulatory agency responsibility for disposal of HLW and spent fuel is described in the Nuclear Waste Policy Act and Energy Policy Act of 1992. NRC is the U.S. regulator for disposal of HLW, including:

- Implementing the applicable standards in 10 CFR Part 63 for the Yucca Mountain site;
- Conducting pre-licensing consultation;
- Certifying transportation packages;
- Hosting meetings at NRC Headquarters and in Nevada and other affected states;
- Implementing and maintaining the high-level waste Licensing Support Network; and
- Performing a comprehensive, independent safety review of DOE's license application and conducting a full and fair public hearing, to ensure an open, objective decision on whether or not to construct a proposed repository at Yucca Mountain.

EPA issued final standards for Yucca Mountain on June 13, 2001, codified at 40 CFR Part 197. NRC published conforming licensing regulations on November 21, 2001, codified at 10 CFR Part 63. These standards and regulations withstood multiple legal challenges, except EPA's regulation governing the time period after disposal for which compliance must be demonstrated. This provision was vacated in July 2004 by the



Court of Appeals for the D.C. Circuit. The Court ruled the compliance period was not consistent with recommendations of the NAS, as required by statute. EPA issued amended standards addressing the Court decision on September 30, 2008. NRC will amend 10 CFR Part 63 to be consistent with EPA's amended standards. See E.2.2.2 for EPA's HLW disposal standards.

NRC regulations contain risk-informed, performance-based criteria for both pre-closure operations and post-closure performance of the proposed geologic repository. EPA standards and NRC regulations are generally consistent with recommendations of the NAS and with national and international recommendations for radiation protection standards.

The NRC Licensing Support Network (LSN) is an internet web-portal that has been established to facilitate discovery process in preparation for the Yucca Mountain repository license application hearings. All parties to the license application hearings are required by NRC regulations to make their collection of documentary materials available on the LSN prior to the commencement of the licensing proceeding. The LSN provides a single place where the parties and potential parties to the licensing hearing can uniformly search for documents. In accordance with NRC regulations, DOE certified its LSN collection before the submittal of the Yucca Mountain license application and made publicly available more than 3.6 million documents relating to the Yucca Mountain licensing on the NRC Licensing Support Network. The LSN requirements are in 10 CFR Part 2, Subpart J.<sup>55</sup>

The NWPAA (Sec. 114) requires NRC issue a final decision approving or disapproving issuing a construction authorization not later than three years after the date of submitting a complete license application. NRC may extend this deadline by not more than 12 months if certain reporting requirements are met.

### **E.2.1.3 LLW Regulation**

Activities supporting NRC's strategic objectives<sup>56</sup> include:

- Assessing key issues affecting the safe management of civilian low-level waste disposal to ensure potential disruption in access to the three licensed disposal sites does not adversely affect licensees' ability to operate safely, and decommission their plants safely;
- Conducting periodic reviews of Agreement State programs to ensure they are adequate to protect health and safety are compatible with NRC's program, and ensure a sound and consistent regulatory framework;
- Working closely with the Agreement States to develop consistent, risk-informed processes to review event information and identify safety issues for materials licensees; and
- Implementing, reviewing and refining materials oversight.

States were in various stages of planning, siting and licensing LLW disposal facilities in the late 1980s and early 1990s in an attempt to meet the milestones of LLRW PAA. NRC

---

<sup>55</sup>The web site is located at: <http://www.lsnnet.gov> and is administered by the Atomic Safety and Licensing Board Panel of NRC.

<sup>56</sup> Extracted from NRC Strategic Plan, (NUREG 1614, Vol. 4) Final, February 2008.

developed a Standard Format and Content guide (NUREG-1199) and a Standard Review Plan (NUREG-1200), providing guidance on licensing LLW disposal facilities enabling NRC to meet its statutory requirements of reviewing a license application within 15 months of receipt, and to provide technical guidance to Agreement States. NRC published a final report, *A Performance Assessment Methodology for Low-Level Radioactive Waste Disposal Facilities: Recommendations of NRC's Performance Assessment Working Group* (NUREG-1573) in October 2002. NRC published<sup>57</sup> the results of the staff's strategic assessment of NRC's LLW regulatory program in October 2007. The results include a prioritized listing of ongoing and future staff actions and activities, along with associated schedules and resource estimates.

#### **E.2.1.4 Decommissioning Regulation**

Decommissioning involves safely removing a facility from service and reducing residual radioactivity to a level permitting the property to be released for unrestricted or restricted use. This action is taken by a licensee before NRC terminates its license. Non-licensed facilities may also be required to decontaminate and decommission the site to meet NRC release limits.

NRC staff developed a number of guidance documents for the Final Rule on Radiological Criteria for License Termination (rule published in July 1997) to help licensees prepare decommissioning documents and provide the staff with uniform criteria for reviewing licensee submittals (see list of decommissioning guidance documents in Annex E-1). The staff also consolidated and updated numerous decommissioning guidance documents in September 2003 into a three-volume guidance, NUREG-1757, *Consolidated Decommissioning Guidance*, which superseded previous material guidance for decommissioning materials sites. NRC's staff further updated the guidance in NUREG-1757 in September 2006. See Section F.6.1 for additional information.

NRC evaluated its licensing process for decommissioning sites and terminating NRC licenses in accordance with 10 CFR Part 20, Subpart E, as part of the Integrated Decommissioning Improvement Plan (IDIP). Its specific purposes included: describing a "continuous improvement" plan for decommissioning during FY 2004-2008; and integrating and tracking regulatory improvements from the License Termination Rule (LTR) analysis, program management improvements from the Decommissioning Program Evaluation, and other staff improvements. Issues considered include:

- Restricted use/institutional controls, including engineered barriers and long-term monitoring;
- On-site disposal;
- Realistic scenarios;
- Removal of material after license termination (relationship of LTR and control of disposition of solid material); and
- Other non-LTR analysis topics (e.g., ground water monitoring)

---

<sup>57</sup> Strategic Assessment of Low-Level Radioactive Waste Regulatory Program, available at <http://www.nrc.gov/reading-rm/doc-collections/commission/secys/2007/secy2007-0180/2007-0180scy.html>

The lessons learned from the IDIP initiative are being factored into the NRC's rulemaking on preventing future legacy sites (See Section F.2.3.4).

Power reactors are licensed to operate under 10 CFR Part 50. Independent spent fuel storage installations (ISFSIs) are licensed under 10 CFR Part 72. NRC can terminate a power reactor license after completing decommissioning if all spent fuel has been removed from the site or placed in an ISFSI under a specific license. NRC cannot terminate a power reactor license if the spent fuel is transferred to an on-site generally licensed ISFSI.

NRC does not issue a specific license for decommissioning a nuclear plant. However, as soon as fuel is permanently removed from the reactor vessel and NRC receives certification of its removal, amends the operating license so that the licensee may no longer operate the reactor or place fuel back into the reactor vessel. Licensees must then submit a Post-Shutdown Decommissioning Activity Report (PSDAR) no later than two years after permanent cessation of operations. The PSDAR defines allowable licensee activities until it submits a license termination plan. Information the licensee is required to include in this PSDAR is at 10 CFR 50.82. NRC does not review every decision licensees make in decommissioning the facility. The licensee may make changes -without prior NRC approval- in the facility and procedures described in the safety analysis report (SAR), or conduct tests or experiments not described in the SAR. These changes must be consistent with specific provisions at 10 CFR 50.59.

Each power reactor licensee must request termination of its license. The application must be accompanied or preceded by a license termination plan (LTP) for NRC approval. The LTP must include information such as identifying remaining dismantlement activities; site remediation planning; detailed plans for the final radiation survey; a description of the end use of the site; an updated cost estimate; and a supplement to the environmental report describing any new information or significant environmental change in with the licensee's proposed termination activities.

The decommissioning process for non-power reactor facilities can be initiated by any number of conditions. These include expiration of the license and cessation of operations in all or part of the site for 24 months. Major steps in the complex materials site decommissioning process include notification, submittal and review of the decommissioning plan (DP), implementation of the DP, and completion of decommissioning. Following approval of the DP, the licensee must complete decommissioning within 24 months or apply for an alternate schedule. NRC staff will inspect the licensee during decommissioning operations to ensure compliance with the DP. These inspections will normally include in-process and confirmatory radiological surveys.

In the final steps of decommissioning of material sites, licensees are required to perform a number of actions including certification of the disposition of all licensed material and performance of a radiation survey of the premises.<sup>58</sup>

---

<sup>58</sup> Specific details for unrestricted versus restricted release, schedules for notification and completion of decommissioning milestones, as well as alternatives in the compliance with regulatory requirements for decommissioning are discussed in greater detail at <http://www.nrc.gov/about-nrc/regulatory/decommissioning/process.html>.

NRC deferred the proposed “clearance” rulemaking, in June 2005, in part, because most large-scale decommissioning projects will not take place for some time. The current approach, despite this deferral, is considered to protect public health and safety. This and the greater urgency for other areas in the regulatory agenda for safety (e.g., recovery of orphaned sources) have also led to the decision to defer this rulemaking. NRC staff continues to address the release of solid materials using license conditions and existing regulatory guidance. Additional information on the release of material from regulatory control is in Section H.1.4.

### **E.2.1.5 NRC’s Integrated Materials Performance Evaluation Program**

NRC, in coordination with the Agreement States, developed and piloted a review process in 1994 for Agreement State and NRC Regional materials programs called the Integrated Materials Performance Evaluation Program (IMPEP). Common performance indicators were established to obtain comparable information on the performance of each program. NRC began full implementation of IMPEP in 1996 to ensure public health and safety are adequately protected from potential hazards of using radioactive materials, and Agreement State programs are compatible with NRC’s program.<sup>59</sup>

IMPEP employs a team of NRC and Agreement State staff to assess both Agreement State and NRC radioactive materials licensing and inspection programs. All reviews use the following common indicators in the assessment and place primary emphasis on performance:

- Technical Staffing and Training;
- Status of Materials Inspection Program;
- Technical Quality of Inspections;
- Technical Quality of Licensing Actions; and
- Technical Quality of Incident and Allegation Activities.

Additional areas are identified as non-common performance indicators (Compatibility Requirements, Sealed Source and Device Evaluation Program, Low Level Radioactive Waste Disposal Program, Uranium Recovery Program, Regional Fuel Cycle Inspection Program, and Site Decommissioning Management Plan) and may also be addressed in the assessment.

Both Agreement States and NRC Regional and Headquarters Offices are reviewed under this program. About 10-12 reviews are scheduled each year. Regions and Agreement States are routinely reviewed every four years, although the frequency may be decreased based on good performance. The final determination of adequacy of each NRC Regional program and both adequacy and compatibility of each Agreement State program, based on the review team’s report, is made by a Management Review Board (MRB), using the review team’s report as a basis for its determination. This Board is composed of NRC managers and an Agreement State program manager who serves as an Agreement State liaison to the MRB.

---

<sup>59</sup> The IMPEP program was selected in 2004 as among the top 50 programs for the “Innovations in American Government Awards,” sponsored by the Ash Institute for Democratic Governance and Innovation at Harvard University’s John F. Kennedy School of Government and administered in partnership with the Council for Excellence in Government.

The Organization of Agreement States is invited to nominate liaisons to participate in MRB meetings as a nonvoting participant. State representatives receive all relevant documents and engage in all MRB discussions except those potentially involving the Agreement State liaison's own state. Agreement States and Regional representatives are also invited to attend their individual MRB meetings to discuss IMPEP team findings with the MRB.

The range of possible findings for an Agreement State program are:

1. Adequate to protect public health and safety, and compatible/not compatible;
2. Adequate, but needs improvement and compatible/not compatible; and
3. Inadequate to protect public health and safety and compatible/not compatible.

NRC Offices are rated in the same manner, but without the additional compatibility finding. IMPEP good practices and lessons learned are made available to all regulatory programs. Additional information on the IMPEP program can be found at the IMPEP Toolbox.<sup>60</sup> Lessons learned reflect input and feedback from Agreement State officials and NRC regional staff.

#### **E.2.1.6 Advisory Committee on Nuclear Waste and Materials**

The Advisory Committee on Nuclear Waste was established in June 1988 to provide independent technical advice to NRC Commissioners on agency activities, programs, and key technical issues on NRC regulation, management, and safe disposal of radioactive waste. The Committee's recommendations are not binding, however. The committee's name was changed in April 2007, to the Advisory Committee on Nuclear Waste and Materials (ACNW&M) to reflect increased responsibilities in the nuclear materials area other than radioactive waste. Effective June 1, 2008, the ACNW&M merged into the Advisory Committee on Reactor Safeguards (ACRS). The Nuclear Regulatory Commission's decision to merge ACNW&M into ACRS was based on the changing workload and technical challenges facing the agency and the anticipated increased need for expertise in health physics, waste management, and earth sciences in the agency's licensing reviews for new reactors, the mixed-oxide nuclear fuel fabrication facility, and facilities related to the Global Nuclear Energy Partnership (GNEP). Moreover, the ACNW&M's role has concluded in recent years as the NRC's low-level waste and decommissioning programs matured. Also, the ACNW&M's activities in high-level waste have decreased as the DOE and the NRC have resolved most key technical issues in DOE's plans for a high-level waste repository; any remaining issues will be addressed in the license application. The expertise will continue as a new subcommittee of the ACRS.

In the past, the ACNW&M interacted with NRC, the ACRS, other Federal, state, and local agencies, tribes, the public, and other stakeholders to fulfill its responsibilities. The bases for the Committee's advice include the regulations for high-level waste disposal, LLW disposal, and other regulations and legislative mandates.<sup>61</sup> The ACNW&M

---

<sup>60</sup> Additional information on IMPEP may be found at <http://nrc-stp.ornl.gov/impeptools.html>

<sup>61</sup> See also report on LLW, NUREG-1853, History and Framework of Commercial Low-Level Radioactive Waste Management in the United States, ACNW&M White Paper at <http://www.nrc.gov/reading-rm/doc-collections/nuregs/staff/sr1853/sr1853.pdf>

examined and reported on areas of concern as requested by NRC Commissioners and may undertake studies and activities on its own initiative.

The ACNW&M was independent of NRC and reported directly to the Commissioners who appoint its members. Advisory committees are structured to provide a forum where experts representing many technical perspectives can provide independent advice for their decision making. Most advisory committee meetings are open to the public and anyone may request an opportunity to make an oral statement during the meeting.<sup>62</sup>

## **E.2.2 U.S. Environmental Protection Agency**

EPA has several radioactive waste regulatory functions. These areas are described in more detail below.

### **E.2.2.1 Waste Isolation Pilot Plant Oversight**

EPA issues radiation standards and certifies compliance of the WIPP disposal facility. The Waste Isolation Pilot Plant Land Withdrawal Act (WIPP LWA), as amended, required EPA to issue final regulations for disposal of spent fuel, HLW, and TRU waste. It also gave EPA authority to develop criteria implementing final WIPP radioactive waste disposal standards. EPA must also determine every five years whether or not the WIPP facility is in compliance with applicable standards. The WIPP LWA also requires EPA to determine whether WIPP complies with other Federal environmental and public health and safety regulations, such as the Clean Air Act and the Solid Waste Disposal Act.

EPA issued final amendments to its radioactive waste disposal standards for SNF, HLW, and TRU radioactive waste on December 20, 1993, initially promulgated in 1985 (40 CFR Part 191). The amendments addressed the individual and groundwater protection requirements of the original standards which had been remanded by the U.S. Court of Appeals. The other portions of the standards were not remanded. The final individual protection standards require disposal systems to limit the amount of radiation to which an individual can be exposed for 10,000 years, rather than for 1,000 years, as was required in the original standard. The final groundwater protection standards require disposal systems be designed so for 10,000 years after waste disposal, contamination in off-site underground sources of drinking water will not exceed the maximum contaminant level for radionuclides established by EPA under the Safe Drinking Water Act.

EPA issued final compliance criteria on February 9, 1996 (40 CFR Part 194) for certification and recertification of WIPP compliance with the final radioactive waste disposal standards (40 CFR Part 191). Containment requirements of Subpart C limit releases of radionuclides to specified levels for 10,000 years after the facility accepts its final waste for disposal, while assurance requirements involve additional measures intended to provide confidence in the long-term containment of radioactive waste. Subpart C also implements disposal standards requirements to protect individuals and ground water from exposure to radioactive contamination. Other Subparts deal with definitions, references, reporting requirements, content of certification and re-certification applications, and the process for public participation.

---

<sup>62</sup> The other information is available at <http://www.nrc.gov/about-nrc/regulatory/advisory/acnw.html>

DOE submitted a Compliance Certification Application (CCA) to EPA on October 29, 1996, to demonstrate WIPP complies with the criteria at 40 CFR Part 194. EPA then conducted a very open certification review process, involving multiple opportunities for written public comments and public hearings. EPA issued a Final Rulemaking Notice on the certification decision on May 18, 1998. WIPP received its first TRU waste shipment on March 26, 1999.

DOE submitted an application for recertification of WIPP in March 2004, which by statute is required every five years. EPA issued its decision to recertify DOE's compliance with the applicable standards on April 10, 2006.

The Office of Radiation and Indoor Air coordinates most EPA actions under the WIPP LWA. Other EPA offices also play important roles concerning WIPP. EPA's Region VI office, based in Dallas, Texas, is responsible for determining WIPP compliance with all applicable environmental laws and regulations other than the radioactive waste disposal standards. The Region VI office also coordinates with EPA's Office of Solid Waste on hazardous waste issues. Some TRU waste intended for disposal at the WIPP also contains hazardous components, subjecting it to the regulations developed under the Resource Conservation and Recovery Act of 1976 (RCRA), as amended.

EPA conducts inspections of both waste generators and WIPP operations. Separate inspections may be conducted for waste characterization activities, quality assurance, or WIPP site activities (procedural or technical). EPA conducted 19 WIPP-related inspections in calendar year 2007, and typically conducts 15-20 per year.

The State of New Mexico is authorized by EPA to carry out the base RCRA and mixed waste programs in lieu of equivalent Federal programs. The New Mexico Environment Department reviews permit applications for treatment, storage, and disposal facilities for hazardous waste, under Subtitle C of RCRA.

#### **E.2.2.2 EPA HLW and Spent Fuel Disposal Standards**

The Energy Policy Act of 1992 required EPA to develop radiation protection standards specifically for the Yucca Mountain site to protect the public and the environment from exposure to radioactive wastes disposed in the repository. Section E.1 addresses the EnPA and the relevant obligations on the EPA, DOE and NRC in greater detail.

EPA's standards in 40 CFR Part 197 (issued in 2001 and amended in 2008) established:

- **Individual-Protection Standard:** An all pathways dose limit of 0.15 mSv/a (15 mrem/yr) for residents living in the vicinity of Yucca Mountain up to 10,000 years after repository closure. An all pathways dose limit of 1 mSv/a (100 mrem/yr) to apply at the time of peak dose beyond 10,000 years and up to 1 million years after closure.
- **Human-Intrusion Standard:** Assessment of the consequences of an intruder drilling a borehole directly through a degraded waste package without recognition and releases transported to the groundwater. The same dose limits and time frames apply as for the individual-protection standards.

- **Ground-Water Protection Standard:** The same dose and concentration limits as EPA’s drinking water standards<sup>63</sup> applicable for up to 10,000 years after closure.

### **E.2.2.3 Mixed Waste Regulation**

A dual regulatory framework exists for mixed waste. EPA or authorized states regulate the hazardous waste component and NRC, NRC Agreement States, or DOE regulate the radioactive component. NRC and DOE regulate mixed waste radiation hazards using AEA authority. EPA regulates mixed waste chemical hazards under its RCRA authority. NRC is authorized by the AEA to issue licenses to commercial users of radioactive materials. RCRA gives EPA authority to control hazardous waste from “cradle-to-grave.” Waste handlers must comply with both AEA and RCRA statutes and regulations once a waste is found to be a mixed waste. The requirements of RCRA and AEA are generally consistent and compatible. The provisions in Section 1006(a) of RCRA allow the AEA to take precedence if provisions of requirements of the two acts are inconsistent.

Land Disposal Restriction regulations, under the 1984 Amendments to RCRA, prohibit disposal of most mixed waste until it meets specific treatment standards for hazardous constituents, which may be based on a concentration or a specific treatment technology. Most commercial mixed waste (generated and stored) can be treated to meet Land Disposal Restriction regulations with commercially available treatment technology. No treatment or disposal capacity is available for a small percentage of commercial mixed waste. Commercial mixed waste volumes are very small (approximately two percent) compared to the total volume of mixed waste being generated or stored by DOE.

DOE has developed Site Treatment Plans to handle its mixed wastes under the Federal Facilities Compliance Act, signed into law on October 6, 1992. These plans are being implemented by orders issued by EPA or the state regulatory authority.

EPA issued regulations in 2001, allowing mixed waste to be exempted from RCRA hazardous waste requirements, as long as it meets NRC or Agreement State requirements. These regulations may be found at 40 CFR Part 266, Subpart N, and apply to:

- Storage at the generator site or another site operating under the same license;
- Treatment in a tank or container at the generator site or another site operating under the same license;
- Transportation to a licensed treatment facility or low-level waste disposal facility; and
- Disposal at a licensed low-level waste disposal facility, as long as the waste meets RCRA treatment standards for hazardous constituents.

### **E.2.2.4 Uranium Mining and Milling Air Emission Standards**

EPA has established National Emission Standards for Hazardous Air Pollutants (NESHAPs) under the Clean Air Act for airborne radionuclide emissions from a variety of

---

<sup>63</sup> Title 40 CFR Part 141, National Primary Drinking Water Regulations.



industrial sources (40 CFR Part 61). Three particular standards relate to uranium mining or mill tailings.

Subpart B of 40 CFR Part 61 protects the public and the environment from the  $^{222}\text{Rn}$  emissions to the ambient air from underground uranium mines. It sets a limit on the emission of  $^{222}\text{Rn}$  ensuring no member of the public in any year receives an effective dose equivalent of more than 0.1 mSv/a (10 mrem/yr). Operating mine ventilation systems discharge large amounts of radon into the atmosphere. Radon in an unventilated mine is hazardous to miners. Ventilating to reduce radon exposure to the miners, however, increases exposure to the general population. Owners/operators of each mine must calculate the effective dose equivalent to any member of the public and report this information to EPA annually.

Subpart T of 40 CFR Part 61 protects people and the environment from  $^{222}\text{Rn}$  emissions from no longer operating uranium mill tailings piles. The  $^{222}\text{Rn}$  emission rate from a uranium mill tailings pile to the surrounding (ambient) air must not exceed 0.74 Bq/m<sup>2</sup>-s (20 pCi/m<sup>2</sup>-s). Subpart T does not apply to NRC's licensees because they are covered by NRC's regulatory system. Releases occur both during and following the processing of uranium ores and originate from residual radioactive material and the disposal of uranium mill tailings. DOE controls 24 abandoned uranium mill tailings piles. The original deadline for bringing uranium mill tailings piles into compliance with the standard was December 15, 1991. EPA establishes compliance agreements with owners or operators of uranium mill tailings piles not in compliance by then to assure they are disposed of as quickly as possible. Owner operators must conduct emissions tests on piles they have sealed to prevent the escape of the radon gas, and notify EPA of both what they have done and the results of the emissions tests.

Subpart W protects the public and the environment from the emission of  $^{222}\text{Rn}$  from active uranium mills and their tailings. The standard limits  $^{222}\text{Rn}$  emissions rate to 0.74 Bq/m<sup>2</sup>-s (20 pCi/m<sup>2</sup>-s) and requires new tailings impoundments meet one of the two following work practices:

1. There are a maximum of two impoundments in operation at any time (including existing impoundments) of no more than 0.16 km<sup>2</sup> (40 acres). Tailings management and disposal is by phased disposal; or
2. Tailings are immediately dewatered and disposed of with no more than 0.04 km<sup>2</sup> (10 acres) uncovered at any time. Operators must also follow applicable NRC requirements in 40 CFR 192.32.

Uranium milling produces large quantities of tailings since uranium ore generally contains less than one percent uranium. These tailings are collected in impoundments varying in size from 0.08 to 1.6 km<sup>2</sup> (20 to 400 acres). The tailings contain large amounts of radium, and therefore, they emit large quantities of radon. Owners or operators must test emissions and report to EPA annually.

### **E.2.2.5 Other EPA Radiation-Related Authorities**

EPA has regulatory responsibilities for a variety of other man-made and naturally-occurring radioactive wastes:

- Developing of general radiation protection guidance to the Federal government. Section F contains additional information about radiation protection;
- Limiting airborne emissions of radionuclides. Subpart H of EPA's NESHAPs standards limit the airborne emissions of radionuclides (other than radon) from DOE sites managing defense-related spent nuclear fuel and radioactive waste. A limit of 0.1 mSv (10 mrem) per year effective dose equivalent is applied to any member of the public in the vicinity of such sites. Emission monitoring is specified, and DOE sites are required to submit an annual compliance report to EPA. Subpart I applied similar requirements to NRC-licensed facilities but was rescinded when NRC established comparable requirements;
- Setting drinking water regulations, under the Safe Drinking Water Act, as amended, including standards for radionuclides in community water systems;
- Remediating of radiologically-contaminated sites listed on the CERCLA National Priorities List (NPL). See Section D.3.6. The NPL includes sites licensed by NRC or Agreement States, as well as DOE sites. EPA and NRC entered into a Memorandum of Understanding (MOU) in October 2002, to avoid future confusion regarding the potential for dual regulation at decommissioned sites. This MOU defines conditions where they would consult on the decommissioning of NRC-licensed facilities;<sup>64</sup>
- Coordinating with state radiation protection agencies to protect the environment, workers, and the public from naturally occurring radioactive materials exposed or concentrated by mining or processing; and
- Coordinating with DOE, NRC and states on orphaned sources, recycled materials, and controlling imports and exports to prevent radioactively-contaminated scrap from entering the United States<sup>65</sup> (See further discussions in Sections I and J.)

EPA is composed of a headquarters organization and 10 regional offices. Each EPA Regional Office is responsible for executing Agency's programs with states in its region. EPA also has 17 laboratories located across the nation.

### **E.2.3 U.S. Department of Energy**

DOE is responsible for regulating management of its radioactive waste and spent fuel, other than the disposal of HLW and spent fuel. DOE spent fuel and radioactive waste management activities designated under the Joint Convention receive independent oversight from DOE's Office of Health, Safety and Security (DOE-HSS).<sup>66</sup>

<sup>64</sup> See OSWER Directives 9295.8-06 and 9295.8-06a at

<http://www.epa.gov/superfund/health/contaminants/radiation/mou.htm>

<sup>65</sup> The U.S. Coast Guard and the U.S. Department of Homeland Security Customs and Border Protection have the lead in detecting and taking steps to prevent the illegal entry of such materials. They have the authority to take enforcement actions and, depending on the circumstances, may seize or have a shipment returned to the point of origination.

<sup>66</sup> The Offices of Environment, Safety and Health (DOE-EH) and Security and Safety Performance Assurance (DOE-OA) were dissolved and reconstituted into the Office of Health, Safety and Security in 2006.

DOE oversight functions performed by DOE-HSS include:

- Ensuring conformance of DOE activities with applicable laws and requirements for protecting the environment, and the safety and health of the public and the workers at DOE facilities;
- Conducting scientific and technical programs to enhance DOE ability to protect the health and safety of workers and the public;
- Developing effective, efficient, and state-of-the-art environmental, occupational safety and health, and medical policies and rules for operation of DOE facilities;
- Providing technical assistance to DOE programs to foster the identification and resolution of environment, safety, health, safeguards, and security issues; and
- Ensuring compliance with nuclear safety requirements.

DOE-HSS under DOE Manual 435.1-1, Chapter I, provides an independent overview of radioactive waste management and decommissioning programs to determine compliance with Department environment, safety and health requirements and applicable EPA and state regulations. DOE regulations in 10 CFR Parts 820 and 830 make DOE nuclear safety requirements subject to enforcement by all means, including civil and criminal penalties.

DOE-HSS develops, manages, and directs comprehensive programs providing effective health and safety policy to protect health and safety of workers, and for facility and systems operations safety. It also maintains a formal liaison role with external safety and health regulators, with internal DOE programs, and line elements and with contractor organizations on health and safety policy and regulatory issues. DOE-HSS develops and manages health and safety programs to improve department-wide safety performance.

DOE-HSS develops, coordinates, and promulgates DOE policy, orders, and standards for safety and health of workers, facilities, and working conditions. It establishes state-of-the-art programs, policies, and standards, assuring protection of DOE Federal and contractor personnel from occupational injury and illness, and safety of facility design and operations. It also ensures the adequacy of health and safety training for DOE and contractor employees.

DOE-HSS develops policies and guidance and implementing strategies for the specialized safety disciplines of nuclear safety, health physics, industrial hygiene, fire protection, electrical safety, high explosives, firearms safety, pressure safety, and chemical safety. It establishes DOE policy and guidance and evaluates risk assessment processes for worker safety. It serves as the primary DOE liaison with the Department of Labor Occupational Safety and Health Administration and NRC on health and safety regulation reviews and pending regulatory reform. It also maintains technical expertise on nuclear safety and occupational safety and health and provides DOE with consulting services to assist workers in understanding and implementing policies, standards, and guidance, in response to compliance and program requirement issues. It develops DOE directives and policies for radiation protection of the public and environment and guidance for environmental protection. These are promulgated as regulations or issued as DOE orders.

The DOE Office of the General Counsel has approval authority for DOE NEPA analyses. It coordinates with and assists in preparing adequate environmental impact statements for major DOE proposed actions. It develops written orders, policies, regulations, and guidance documents for environmental review requirements and implementation.

DOE-HSS performs independent technical reviews of facility nuclear safety authorization basis documents and the implementing process to ensure establishing and maintaining of an adequate safety margin, and control hazards from DOE activities during routine and abnormal conditions for all facility life cycles. It also performs facility reviews, walk-downs, and personnel interviews to ensure actual facility conditions (including operations, where appropriate) are consistent with the authorization basis.

DOE-HSS is responsible for investigations of potential violations of enforceable requirements, as well as nuclear safety concerns raised by workers at DOE facilities. It initiates and resolves enforcement actions where warranted in accordance with the process and procedures of 10 CFR Part 820.

The primary mechanism for enforcement is contractor self-identification and reporting of potential non-compliant activities as set forth in 10 CFR Part 820, Appendix A (Enforcement Rule and Policy). The incentive for contractor self-reporting lies in DOE Enforcement Policy, providing up to 100 percent mitigation of civil penalties when contractors promptly identify, report, and correct violations. The fundamental tenet of the enforcement policy is to focus on those violations causing regulatory concern because of their actual or potential safety significance. Analysis of existing nuclear safety related events information is used to develop safety significance threshold for evaluating potential violations for enforcement.

DOE's Office of Price-Anderson Enforcement maintains the internal self-regulatory program; investigates potential violations; and, where warranted, initiates enforcement action including recommending whether civil penalties should be imposed. Those actions are performed according to processes and procedures in 10 CFR Part 820. DOE enforces two substantive nuclear safety rules: 10 CFR Part 830 Subpart A, *Quality Assurance* and Subpart B, *Safety Basis Requirements*, and 10 CFR Part 835, *Occupational Radiation Protection*. Other requirements found at 10 CFR 820.11, *Information Requirements*, and 10 CFR Part 708, *DOE Contractor Employee Protection Program*, are also subject to DOE enforcement.

DOE ensures contractor accountability by conducting investigations and program reviews at selected sites. Two concerns have arisen: (1) issues are sometimes revealed by safety events preventable through effective performance assessment programs, and (2) corrective actions are sometimes not effective in preventing recurrence. DOE developed and maintains the Noncompliance Tracking System (NTS) database where contractors voluntarily report non-compliances. Because DOE enforcement policy provides substantial incentives for contractors to self-identify, report, and correct nuclear safety concerns, voluntary reports into the NTS may result in enforcement discretion. DOE may either forego or mitigate enforcement action. Some contractors have begun to move from "event-driven" to "assessment-driven" NTS reports, indicating a proactive approach to identifying issues and taking actions to address them.

DOE's Office of Independent Oversight within HSS performs independent inspections and assessments of DOE facilities, including the functional area of environmental compliance and safety and health. The authority to conduct independent oversight is formally established through DOE Order 470.2B, *Independent Oversight and Performance Assurance Program*. The requirements in DOE Order 470.2B detail the basis for independent oversight activities; conduct of appraisals; response to significant vulnerabilities; reporting of appraisal results; and the corrective action development, approval and closure (follow-up) process for all findings, issues, or concerns identified during appraisals. The changing mission of many DOE facilities, as well as the aging of those facilities, increases the importance of assessing HSS policies and programs, as well as implementing those programs, to evaluate their effectiveness in protecting workers, the public, and the environment. The Office of Independent Oversight also ensures identified deficiencies and other important issues are tracked and corrective actions are taken.

#### **E.2.4 Defense Nuclear Facilities Safety Board**

The Defense Nuclear Facilities Safety Board (DNFSB) is an independent Federal agency established by Congress in 1988. DNFSB's mandate under the Atomic Energy Act is to make nuclear safety recommendations concerning DOE defense nuclear facilities. DNFSB reviews and evaluates the content and implementation of DOE health and safety standards for design, construction, operation, and decommissioning of defense nuclear facilities. DNFSB must then recommend to the Secretary of Energy any specific measures, such as changes in content and implementation of those standards, DNFSB believes should be adopted to ensure the public health and safety are adequately protected. DNFSB also reviews the design of new defense nuclear facilities before construction begins, as well as modifications to older facilities, and is required to recommend changes to protect health and safety. Independent review and advisory responsibilities of the DNFSB continue throughout the full life cycle of facilities, including shutdown and decommissioning.

#### **E.2.5 Nuclear Waste Technical Review Board**

Congress created the U.S. Nuclear Waste Technical Review Board (NWTRB) in 1987 to independently review Yucca Mountain technical activities. The NWTRB authorized a board of 11 part-time members. The NAS recommends candidates, and the President makes the appointments. NWTRB is an independent Federal agency and reports its conclusions and recommendations to Congress and DOE at least two times a year.

#### **E.2.6 National Council on Radiation Protection and Measurement**

The National Council on Radiation Protection and Measurement (NCRP) is a private, Congressionally-chartered organization of radiation protection experts established in 1964. It has predecessor functions dating back to 1928, such as formulating and disseminating information, guidance, and recommendations on radiation protection and measurements, representing the consensus of leading scientific thinking. NCRP recommendations are important to radiation users, the public, and other state, national and international groups concerned with radiation matters. Individuals and industrial organizations employing radiation sources turn to these recommendations to be sure their equipment and practices embody the latest concepts in radiation protection. Non-governmental groups concerned with improving protection efforts and disseminating

information on radiation protection look to NCRP for guidance. Governmental organizations, including NRC, EPA, DOE, the U.S. Public Health Service, and state governments consider NCRP recommendations when formulating the scientific and policy basis of their radiation protection activities. NCRP also works closely with various international bodies concerned with radiation protection, such as ICRP.

## **E.2.7 Regulatory Authorities of States**

Provisions of law allow Federal agencies to delegate or relinquish certain regulatory responsibilities to the states having radioactive materials or nuclear facilities. More complex facilities such as nuclear power plants are regulated by Federal authorities. Regional arrangements allow closer coordination, such as using radioisotopes for medical uses. These arrangements are not necessarily mandatory, but where the state can demonstrate adequate competencies, the appropriate Federal agency can transfer regulatory authority.

### **E.2.7.1 EPA Authorized States**

EPA delegates authorities to states in two areas of radioactive waste management. NESHAPs regulations are based on the requirements of the Clean Air Act law, and the authority for delegating to states is described by law. A state must have emission limits at least as stringent as EPA's national standards. For a state to be delegated authority, it must develop state implementation plans (SIPs) explaining how the state will do its job. A SIP is a collection of the regulations a state will use in remediating polluted areas. The states must involve the public, through hearings and opportunities to comment, in developing each SIP. EPA must approve each SIP, and if a SIP is not acceptable, EPA can take over enforcing the Clean Air Act. EPA and the states inspect regulated facilities periodically, can fine violators, and have other enforcement authority. A state is not required to apply for all aspects of the NESHAPs program, and EPA can approve delegation of some requirements while denying others. Most states have not pursued delegation of radionuclide NESHAPs. The law also allows the public to sue the government to provide and enforce standards.

EPA's process for delegating RCRA hazardous waste requirements to states is similar. The state must have a program at least as stringent as EPA's, and the application for authorization must address specific areas of compatibility. The statutory basis for specific rules, however, may differ. Some "base" requirements must be adopted by states, while states may choose not to adopt other rules. The rule issued by EPA in 2001, and described in Section E.2.2.3, allowing mixed radioactive and hazardous waste generators to remain exempt from the hazardous waste requirements, for example, is not immediately effective in authorized states because it provides for a less stringent method of managing these wastes. Authorized states can choose to adopt all, part, or none of this rule (for example, states without disposal facilities will be unaffected by those provisions, but the provisions related to storage are more widely applicable). If the rule is adopted, however, EPA must authorize the state to implement it. As of September 30, 2007, 33 states had adopted all or part of the rule, and 15 had been authorized to implement it.

Only two states are not authorized for the “base” RCRA program, but some states have chosen to issue more stringent regulations in some areas (for example, states can declare certain wastes as hazardous even if EPA does not). Similarly, authorized states may approve disposal of certain types of radioactive material in a hazardous waste landfill. The program elements required to be addressed in a state’s application for authorization are described in 40 CFR 271.5. EPA approves a state’s application through rulemaking, including announcement in the Federal Register and incorporation into 40 CFR Part 272. Other than adoption of the “base” EPA program, there is no requirement for state programs to be compatible with each other. Information on areas where a state’s program differs from EPA requirements may be obtained from individual states.

### **E.2.7.2 NRC Agreement States**

The Atomic Energy Act of 1954 (AEA), as amended, provides a statutory basis for NRC to relinquish to the states portions of its authority to license and regulate byproduct materials (radioisotopes); source materials (uranium and thorium); and certain quantities of special nuclear materials. As of April 2008, 35 of the 50 states have entered into Agreements with NRC. Three states have filed intent to become Agreement States.

Agreement States are those states having entered into an effective regulatory discontinuance agreement with NRC under subsection 274b. of the AEA. The role of the Agreement States is to regulate most types of radioactive material in accordance with the compatibility requirements of the AEA. These types of radioactive materials include source material (uranium and thorium), reactor fission byproducts, byproduct materials as defined in Section 11.e of the AEA, and quantities of special nuclear materials (SNM) not sufficient to form a critical mass. NRC under its own internal practices, periodically reviews the performance of each Agreement State to assure compatibility with its regulatory standards. See Section E.2.1.5 on NRC’s Integrated Materials Performance Evaluation Program (IMPEP).

Agreement States issue radioactive material licenses, promulgate regulations, and enforce those regulations under the authority of each individual state’s laws. The Agreement States conduct their licensing and enforcement actions under direction of the governors in a manner compatible with the licensing and enforcement programs of NRC.

NRC assistance to states entering into agreements includes review of requests from states to become Agreement States, or amendments to existing agreements, meetings with states to discuss and resolve NRC review comments, and recommendations for NRC approval of proposed agreements. NRC also conducts training courses and workshops; evaluates technical licensing and inspection issues from Agreement States; evaluates state rule changes; participates in activities conducted by the Organization of Agreement States<sup>67</sup> and the Conference of Radiation Control Program Directors, Inc.; and provides early and substantive involvement of the states in NRC rulemaking and other regulatory efforts. NRC also coordinates with Agreement States on event reporting and information and responses to allegations reported to NRC involving Agreement States.

---

<sup>67</sup>See <http://www.agreementstates.org> for more information.

This page intentionally left blank



## F. GENERAL SAFETY PROVISIONS

Section F addresses general safety provisions in Articles 21-26 of the Joint Convention including:

- Responsibility of license holders;
- Human and financial resources;
- Quality assurance;
- Operational radiation protection;
- Emergency preparedness; and
- Decommissioning.

This section also addresses Articles 4-9 and Articles 11-16. The following provisions are common for both spent fuel and radioactive waste management:

- General safety requirements;
- Existing facilities;
- Siting of proposed facilities;
- Design and construction of facilities;
- Facility safety assessment; and
- Facility operation.

Sections G and H, address these same areas plus Articles 10 and 17 for Spent Fuel Disposal and Institutional Measures after Closure, and provide additional information specific to management of spent fuel or radioactive waste.

Section E presents the various regulations and directives, many of which are referenced in the following sections governing safety requirements in the U.S, including those for spent fuel management. Most of these regulations are available electronically on the internet (see Table A-2).

### F.1 Responsibilities of the License Holder (Article 21)

The Joint Convention specifies each Contracting Party must ensure the prime responsibility for safety rests with the licensee, and each licensee take the appropriate steps to meet its responsibility. The government has the responsibility if there is no licensee. NRC regulations ensure its licensees are responsible for safety. DOE's Integrated Safety Management Program described in Section F.7.2 fulfills responsibility for the U.S. Government spent fuel and radioactive waste management facilities.

#### F.1.1 Safety Responsibility of NRC and Agreement State License Holders

The licensee/operator is ultimately responsible for safe radioactive waste and spent fuel management. Commercial licensees or operators will eventually transfer control to Federal or state governmental agencies, which in turn will be responsible for the short- and long-term protection of the public and the environment.

A. Introduction
B. Policies & Practices <ul style="list-style-type: none"><li>▪ Article 32, paragraph 1</li></ul>
C. Scope of Application <ul style="list-style-type: none"><li>▪ Article 3.</li></ul>
D. Inventories & Lists <ul style="list-style-type: none"><li>▪ Article 32, paragraph 2</li></ul>
E. Legislative & Regulatory Systems <ul style="list-style-type: none"><li>▪ Article 18. Implementing Measures</li><li>▪ Article 19. Legislative &amp; Regulatory Framework</li><li>▪ Article 20. Regulatory Body</li></ul>
<b>F. General Safety Provisions</b> <ul style="list-style-type: none"><li>▪ Article 21. Responsibility of License Holder</li><li>▪ Article 22. Human &amp; Financial Resources</li><li>▪ Article 23. Quality Assurance</li><li>▪ Article 24. Operational Radiation Protection</li><li>▪ Article 25. Emergency Preparedness</li><li>▪ Article 26. Decommissioning</li></ul>
G. Safety of Spent Fuel Management <ul style="list-style-type: none"><li>▪ Article 4. General Safety Requirements</li><li>▪ Article 5. Existing Facilities</li><li>▪ Article 6. Siting of Proposed Facilities</li><li>▪ Article 7. Design &amp; Construction of Facilities</li><li>▪ Article 8. Facility Safety Assessment</li><li>▪ Article 9. Facility Operation</li><li>▪ Article 10. Spent Fuel Disposal</li></ul>
H. Safety of Radioactive Waste Management <ul style="list-style-type: none"><li>▪ Article 11. General Safety Requirements</li><li>▪ Article 12. Existing Facilities &amp; Past Practices</li><li>▪ Article 13. Siting of Proposed Facilities</li><li>▪ Article 14. Design &amp; Construction of Facilities</li><li>▪ Article 15. Facility Safety Assessment</li><li>▪ Article 16. Facility Operation</li><li>▪ Article 17. Institutional Measures After Closure</li></ul>
I. Transboundary Movement <ul style="list-style-type: none"><li>▪ Article 27.</li></ul>
J. Disused Sealed Sources <ul style="list-style-type: none"><li>▪ Article 28.</li></ul>
K. Planned Activities to Improve Safety
Annexes

The United States has, as noted in Section B.4.1, a comprehensive management system, including production, treatment, conditioning and disposal, for most LLW. Commercial LLW disposal facilities currently in operation today were designed, constructed, and operated under licenses issued by Agreement States, based upon NRC health and safety requirements. The United States relies primarily on a system of legal mechanisms such as licenses, orders, permits and compliance agreements for commercial licensees, who possess, process, handle, store, transport and dispose or release radioactive materials. Likewise when NRC Agreement States and EPA Authorized States regulate the possession, manufacturing, handling, transporting, and other related activities, the regulated commercial entities are usually bound by legal instruments and are subject to inspection and enforcement with respect to the regulated activities and facilities. The Agreement States also license most of the “processors” i.e., companies processing the waste for the waste producers in preparation for disposal. The Federal or state regulating authorities are normally not involved in the commercial relations between the waste producers, waste processors, or operators of the disposal sites. The Federal government also uses various other mechanisms to implement statutory responsibilities, including Memorandum of Understanding (MOU)s, compliance agreements with permit holders, and relinquishing authority to states. The MOU is often used in the context of overlapping authorities between two or more Federal agencies.

### **F.1.2 Integrated Safety Management at DOE**

DOE’s Integrated Safety Management System (ISMS) applies to all programs and activities within the agency, including spent fuel management. Integrated safety management is an overarching combination of all elements of environment, safety, and health into one system focused on accomplishing work safely. This is accomplished by formal processes building in rigorous safety discipline from definition and planning of work, through performance of work, and lessons learned/feedback. Additional information on the ISMS framework can be found in DOE Order 450.1 and associated guides.<sup>68</sup>

ISMS focuses on the responsibility of line management, and of all workers, to protect the environment, safety and health. DOE Policy 450.4 also states “as a complement to line management, DOE’s Health, Safety and Security (DOE-HSS) provides ...enforcement and independent oversight functions.” Regulatory procedures are published in 10 CFR Part 820, *Procedural Rules for DOE Nuclear Activities*. Independent oversight includes: (1) DOE-HSS, reporting directly to the Secretary of Energy, and providing an independent assessment of the effectiveness of policies and programs in environment, safety and health, emergency management, safeguards and security, including cyber security; (2) DOE’s Office of Price-Anderson Enforcement, implementing DOE’s statutory authority under Section 234A of the Atomic Energy Act (AEA) to apply sanctions to contractors for unsafe actions or conditions violating nuclear safety requirements for protecting workers and the public; and, (3) the Defense Nuclear Facilities Safety Board, providing recommendations on safety to the Secretary of Energy.

---

<sup>68</sup> See <http://www.hss.energy.gov/index.html>

## F.2 Human and Financial Resources (Article 22)

Both commercial (NRC-regulated) and government (DOE) sectors have requirements to ensure human and financial resources are sustained for spent fuel and radioactive waste management activities. Table F-1 provides information from NRC on human resources in terms of full-time equivalent staff dedicated to regulation in various programmatic areas. It should be noted that these are the resources requested in NRC's FY 2009 budget.

Budgeted Program	FTEs during FY 2009
Nuclear Reactor Safety	2937
Nuclear Materials and Waste Safety	748
High-Level Waste Repository	98
Inspector General	51

Source: Nuclear Regulatory Commission

Table F-2 provides a breakdown for radioactive waste, spent fuel and enforcement. The programmatic categories of nuclear materials and waste safety and HLW repository consist of 846 full time equivalent (FTE) staff. Approximately 40 percent of these FTEs are allocated to nuclear waste and spent fuel management.

Regulatory Program <sup>69</sup>	FTEs Requested for FY 2009
High-Level Waste	98
Spent Fuel Storage and Transportation (includes licensing and inspection)	104
Decommissioning and Low-Level Waste	139
Subtotal Nuclear Waste & Spent Fuel Management	341
	FTEs during CY 2006
Enforcement <sup>70</sup>	19

DOE field and program offices have primary regulatory functions at DOE through oversight of, and assuring compliance by, the management and operating contractors who manage and operate sites and facilities. Other DOE headquarters organizations provide an additional layer of independent oversight. DOE's accounting and budgetary structure is different from the Nuclear Regulatory Commission. Staffing for the specific DOE headquarters organization is as follows: The HSS Office of Independent Assessment has a staff of 28 individuals assigned specifically to environment, safety and health evaluations. The Office of Enforcement has a staff of nine at headquarters who are engaged in safety, health and Price-Anderson Enforcement. There are also Price-Anderson Coordinators in DOE Program Operations, Field and Area Offices. The Chief of Nuclear Safety in the Office of the Undersecretary has a staff of eight who provide regulatory oversight. In DOE-NNSA there are four staff members in the Office of the

<sup>69</sup> Source: <http://www.nrc.gov/reading-rm/doc-collections/nuregs/staff/sr1100/v23/sr1100.pdf>

<sup>70</sup> Source: <http://www.nrc.gov/reading-rm/doc-collections/enforcement/annual-rpts>. The NRC's Enforcement staffing level was for the calendar year of 2006.

Administrator and 10 under the Chief of Defense Nuclear Safety who provide regulatory oversight. In the Office of Environmental Management, the Chief Operations Officer reports directly to the Assistant Secretary for Environmental Management and is independent of all projects. In the Office of Safety Management, which reports directly to the Chief Operations Officer, there is a staff of nine individuals who provide oversight of operations.

The Defense Nuclear Facility Safety Board had 98 FTEs in 2008.

### **F.2.1 Personnel Qualifications for NRC Licensees**

NRC regulations require applicants and licensees to have qualified personnel. The requirements provide for an organizational structure of the applicant, both off site and on site, including a description of lines of authority and assignments of responsibilities, whether in the form of administrative directives, contract provisions, or otherwise. NRC also has qualification requirements for its personnel working on spent fuel and radioactive waste management regulatory activities. References for NRC qualification protocols are in Annex F-1.

NRC establishes qualifications for those operational employees responsible for safety and radiological health. These also include the radiation safety officer and health physics personnel. The technical qualifications include training and experience so the applicant and members of the applicant's staff are competent to engage in the proposed activities. The applicant must additionally establish a personnel training program and a plan to maintain an adequate complement of trained personnel to carry out licensed activities in a safe manner.

Operations of systems and components identified as important to safety must be performed only by trained and certified personnel or by personnel under the direct visual supervision of an individual with training and certification in such operation. Supervisory personnel directing operations important to safety must also be certified in such operations. For certain materials licenses, applicants must be qualified by training and experience to use the material for the purpose requested in such manner as to protect health and minimize danger to life and property.

The physical condition and the general health of personnel certified for radioactive waste and spent fuel management operations important to safety may not be such as might cause operational errors endangering the public health and safety. Any condition potentially causing impaired judgment or motor coordination must be considered in the selection of personnel for activities important to safety. These conditions need not categorically disqualify a person, as long as appropriate provisions are made to accommodate the conditions.

### **F.2.2 DOE Qualification Requirements**

DOE places requirements on contractors for training, proficiency testing, certification, and qualification of operating and supervisory personnel. DOE has training requirements for nuclear safety management in 10 CFR Part 830 and radiation worker protection in 10 CFR Part 835.

DOE directives impose additional training and qualification requirements for its activities. DOE implemented a plan requiring its managers to develop a staffing plan identifying critical technical capabilities and positions essential to safe operations at defense nuclear facilities as a result of a recommendation by the DNFSB in 1993. The staffing plan provides a basis for assessing staffing needs and filling technical vacancies.

DOE is committed to developing and maintaining a technically competent workforce to accomplish its missions in a safe and efficient manner through the Federal Technical Capability Program. DOE, through this program, strives to recruit and hire technically capable personnel, continuously develop the technical expertise of its existing workforce and, retain critical technical capabilities within DOE at all times. DOE is committed to continue making improvements in the capabilities of the Federal workforce and to fully use all of the tools at its disposal.

### **F.2.3 Financial Surety**

Licensees in the commercial sector must meet NRC requirements for financial surety. Spent fuel and radioactive waste management activities in the government sector (DOE facilities) have the financial assurance of the U.S. Government. Annual appropriations are made by the Congress. Special considerations are discussed below for the proposed Yucca Mountain repository, where disposal of both government and commercial spent fuel and high-level waste are proposed. For nuclear materials facilities and activities regulated in NRC Agreement States, commercial licensees must meet the Agreement State financial assurance provisions.

#### **F.2.3.1 Commercial LLW Management Facilities**

The financial information must be sufficient to demonstrate the financial qualifications of the applicant are adequate to carry out the activities for which the license is sought and meet other financial assurance requirements. Each applicant must show it either possesses the necessary funds or has reasonable assurance of obtaining the necessary funds, or a combination of the two, to cover the estimated costs of conducting all licensed activities over the planned operating life of the project, including costs of construction and disposal.

Waste processors are subject to NRC regulations at 10 CFR 20.1403 (or equivalent regulations in Agreement States). These regulations require sufficient financial assurance to enable an independent third party, including a governmental custodian of a site, to assume and carry out responsibilities for any necessary control and maintenance of the site where the license is terminated with restrictions on future site use. The financial assurance mechanism and amount are reviewed and approved by NRC before the license is terminated. No post-closure activities or institutional controls are needed for sites released after closure without restrictions on future site use.

The licensee's surety mechanism for commercial disposal facilities is reviewed annually by NRC to assure sufficient funds are available for completion of the closure plan, assuming the work has to be performed by an independent contractor. NRC regulations (10 CFR 61.62) require funding for disposal site closure and stabilization of commercial waste disposal sites. The applicant must provide assurance sufficient funds are available to carry out disposal site closure and stabilization, including: (1) decontamination or dismantlement of land disposal facility structures; and (2) closure

and stabilization of the disposal site so the need for ongoing active maintenance by the ultimate site owner is eliminated to the extent practicable and only minor custodial care, surveillance, and monitoring are required. The applicant's cost estimates must take into account total capital costs incurred if an independent contractor were hired to perform the closure and stabilization work.

NRC accepts financial sureties consolidated with earmarked financial or surety arrangements established to meet requirements of other Federal or state agencies and/or local governing bodies for such decontamination, closure and stabilization to avoid unnecessary duplication and expense. NRC accepts this arrangement only if it is adequate to satisfy these requirements and the portion of the surety, covering the closure of the disposal site, is clearly identified and committed for use for these activities.

The amount of surety changes with the predicted cost of future closure and stabilization. Factors affecting closure and stabilization cost estimates include: inflation, increases in the amount of disturbed land, changes in engineering plans, closure and stabilization already accomplished, and other conditions affecting costs. This yields a surety sufficient at all times to cover the costs of closure of the disposal units expected to be used before the next license renewal. The term of the surety mechanism is open-ended unless it can be demonstrated another arrangement would provide an equivalent level of assurance.

Financial surety arrangements generally acceptable to NRC include: surety bonds, cash deposits, certificates of deposit, deposits of government securities, escrow accounts, irrevocable letters or lines of credit, trust funds, and combinations of the above or other arrangements approved by NRC. Self-insurance, or any arrangement constituting pledging the assets of the licensee, does not satisfy the surety requirement for private sector applicants since this provides no additional assurance other than through license requirements.

Further financial assurances for institutional controls are found at 10 CFR 61.63. The state has responsibility for review and acceptance of financial sureties in Agreement States.

### **F.2.3.2 Spent Fuel and HLW Management Facilities**

The Nuclear Waste Policy Act of 1982 (NWPAA) requires utility customers receiving benefits of electricity generated by nuclear power to pay all costs associated with development of a geologic repository to dispose of spent fuel and high-level wastes. These consumers currently pay a fee of \$0.001 per kilowatt-hour of nuclear power generated and sold. It is collected by utilities and deposited into the Nuclear Waste Fund (NWF). Utility fees and NWF investment income together amount to approximately \$1.7 billion per annum. Since the Fund's inception in 1983 through June 30, 2008, it has accumulated over \$27.7 billion and expended approximately \$7.1 billion, leaving a net balance of approximately \$20.6 billion. Congress makes an annual appropriation from the NWF, plus a separate annual appropriation to cover disposal costs for defense spent fuel HLW and other government-owned wastes to be disposed of in the repository such as research reactor fuels. Financial and technical assistance funds from the NWF are also provided to the State of Nevada and local counties affected by the Yucca Mountain site (nine in Nevada and one in California), conducting oversight and monitoring activities as required by Nuclear Waste Policy Amendments Act of 1987 (NWPAA). A

certified public accounting firm conducts an independent audit of the NWF annually and DOE submits the audit report to the Congress.

As required by Section 302(a)(4) of the NWPA, the Secretary of Energy is responsible for reviewing the amount of fees paid by the nuclear utilities, and determining whether sufficient funds are being collected. As part of this process, DOE conducts a formal analysis of the costs: *Total System Life Cycle Cost of the Civilian Radioactive Waste Management Program*. An adequacy assessment of the fees to cover the costs associated with the disposal of commercial spent fuel is also conducted. If the Secretary determines there are insufficient or excess revenues, the Secretary is required to propose an adjustment to Congress.

On August 5, 2008, DOE released a revised estimate of the total system life cycle cost for a repository at Yucca Mountain, Nevada. The 2007 total system life cycle cost estimate includes the cost to research, construct and operate Yucca Mountain during a period of 150 years, from the beginning of the program in 1983 through closure and decommissioning in 2133. The new cost estimate of \$79.3 billion, when updated to 2007 dollars comes to \$96.2 billion, a 38 percent increase from the last published estimate in 2001 of \$57.5 billion. This updated estimate takes into account a substantial increase in the amount of waste to be shipped and stored at the repository and more than \$16 billion for inflation. DOE is not proposing a change in the fee paid by nuclear utilities for the disposal of commercial spent nuclear fuel at this time.

Financial assurance for the storage of spent fuel is required under provisions at 10 CFR 72.22 for specifically licensed non-DOE ISFSIs to ensure funds are available to store spent fuel in ISFSIs and for future decommissioning of nuclear reactor facilities. ISFSI general licensees are covered by the financial assurance requirements in 10 CFR Part 50 for a reactor licensee. Financial mechanisms used include surety/insurance or other guarantee method, external sinking funds, government statement of intent, or contractual obligations on the part of the firm's customers.

### **F.2.3.3 Uranium Recovery Waste Management Facilities**

Financial surety arrangements must be established by each mill operator prior to the start of operations to assure sufficient funds will be available to carry out the decontamination and decommissioning of the mill and site and for the reclamation of any tailings or waste disposal areas in the event the licensee is unable to do so. This process is similar for both conventional mills and ISLs; the main difference is that ISLs have no permanent waste disposal areas. As a result, the long-term surveillance charge and transfer of the site to an agency of the U.S. Government does not apply at ISLs.

The amount of funds to be guaranteed by such surety arrangements must account for costs of an independent contractor for performing the work and must be based on NRC-approved cost estimates which address:

- Decontamination and decommissioning of buildings and the site; and
- Reclamation of tailings and/or waste areas in accordance with technical criteria in Section I of Appendix A to 10 CFR Part 40.

The surety must also cover payment of the charge for long-term surveillance and control at conventional mill sites. The licensee's surety is reviewed annually by NRC to

recognize any increases or decreases resulting from inflation, changes in engineering plans, activities performed, and any other conditions affecting costs.

This process yields a surety at least sufficient at all times to cover the costs of decommissioning and reclamation of the areas expected to be disturbed before the next license renewal. Financial surety arrangements generally acceptable to NRC are surety bonds, cash deposits, certificates of deposits, deposits of government securities, irrevocable letters or lines of credit, and combinations of the above or other arrangements approved by NRC.

A minimum charge of \$250,000 (indexed to 1978 U.S. dollars) to cover the costs of long-term surveillance is paid by each mill operator to the General Treasury of the United States or to an appropriate state agency prior to the termination of a uranium or thorium mill license.

A variance in funding requirements may be specified by NRC if site surveillance or control requirements at a particular site are determined, on the basis of a site-specific evaluation, to be significantly greater than annual site inspections.<sup>71</sup> Eventual ownership of the uranium mill disposal site will be to either DOE or an appropriate state agency for perpetuity.

#### **F.2.3.4 Complex Material Sites Decommissioning**

Many of the existing NRC regulated decommissioning sites are complex and difficult to decommission for a variety of financial, technical, or programmatic reasons. These sites can be thought of as NRC “legacy” sites; those sites where past financial or operational events have created the problems needing cleanup solution, and ultimately complete decommissioning and license termination. NRC evaluated the lessons from these existing legacy sites and is conducting a rulemaking to change its current financial assurance and licensee operational requirements to minimize or prevent future legacy sites.<sup>72</sup>

NRC experience applying the financial assurance regulations has resulted in many lessons for improving the regulations and reducing the risks to decommissioning financial assurance. NRC evaluated options for each of these funding risks and made recommendations for both existing and future material licensees. New recommendations from this process include using a risk-informed approach to identify high risk operational indicators (e.g., spills, ground water contamination, and facility modification) and requiring updates to decommissioning cost estimates and financial assurance coverage.

The cost to decommission these facilities ranges broadly, from a few thousand up to the hundred million dollar range. For licensees whose decommissioning costs are less than \$113,000, the NRC does not require setting aside funds for decommissioning. The primary factor affecting the cost of decommissioning is the amount of radioactive

---

<sup>71</sup> Conducted by the government agency responsible for long-term care of the disposal site to confirm its integrity and to determine the need, if any, for maintenance and/or monitoring, e.g., if fencing is necessary.

<sup>72</sup> Lessons learned from NRC’s experiences in decommissioning can accessed at <http://www.nrc.gov/about-nrc/regulatory/decommissioning/lessons-learned.html>



material the licensee is authorized to possess under its license. Other important factors include the physical form of the material (whether it is sealed or not) and the extent of contamination at the facility.

The majority of licensees have possession limits low enough that they may provide financial assurance according to a schedule. Licensees that are authorized to possess relatively large amounts of radioactive material must perform a site-specific cost estimate based on conditions at the facility to arrive at the necessary amount of financial assurance, and they must submit a decommissioning funding plan (DFP) to describe how they will fund the decommissioning costs. The DFP must be updated every 3 years. Licensees must provide financial assurance for decommissioning costs before they begin operations that could result in contamination that needs to be cleaned up.

NRC regulations at 10 CFR 20.1406, *Minimization of Contamination*, specifically require that new applications describe how design and operations will minimize contamination and facilitate eventual decommissioning. To help prevent future legacy sites, NRC published a Commission Paper,<sup>73</sup> which describes a two-faceted approach focusing on financial assurance and monitoring. NRC has been working on this rulemaking and expects to publish it in calendar year 2009.<sup>74</sup> Waste minimization is more fully discussed in F.7.2.

Additional details on financial assurance in decommissioning material sites can be found in Consolidated NMSS Decommissioning Guidance, Financial Assurance, Recordkeeping, and Timeliness (NUREG-1757, Vol. 3).<sup>75</sup>

### **F.3 Quality Assurance (Article 23)**

The following subsections provide a summary of quality assurance (QA) requirements prescribed by NRC and DOE for spent fuel and waste management activities. QA requirements apply to licensees, licensed subcontractors, DOE contractors and subcontractors, and to suppliers.

For commercial licensees, NRC generally inspects the facilities and activities irrespective of organizational affiliation. NRC holds the organization specified in the license as the responsible party for enforcement purposes. Similarly, DOE holds its prime contractors responsible for all subcontractors in addition to direct enforcement authority over subcontractors under the Price-Anderson Act.<sup>76</sup>

NRC has a program of announced and unannounced periodic inspections to provide confidence the licensee is maintaining safety and radiation protection criteria in its daily operations. NRC holds the organization specified in the license as the responsible party for enforcement purposes. See Annex F-1 for procedures related to spent fuel and radioactive waste inspections.

---

<sup>73</sup> SECY-07-0177, "Proposed Rule: Decommissioning Planning (10 CFR Parts 20, 30, 40, 50, 70 and 72: RIN: 3150-AH45)," dated October 3, 2007

<sup>74</sup> On January 22, 2008 (73 FR 3812), NRC published for public comment a proposed rule on Decommissioning Planning. The public comment period has been extended to May 8, 2008.

<sup>75</sup> See <http://www.nrc.gov/reading-rm/doc-collections/nuregs/staff/sr1757/v3/index.html>.

<sup>76</sup> For further information on this subject, refer to the U.S. Atomic Energy Act, Sections 234a and 170d.

### F.3.1 NRC Quality Assurance

Specific technical information needed for adequate demonstration of the performance objectives and the applicable technical requirements for a LLW disposal operation, includes a description of the quality assurance program, tailored to LLW disposal, developed and applied by the applicant for the determination of natural disposal site characteristics and for quality assurance during the design, construction, operation, and closure of the land disposal facility and the receipt, handling, and emplacement of waste. [10 CFR 61.12(j)] Guidance to applicants on how to meet the QA regulatory requirements in Part 61 is also provided in NUREG-1293, Revision 1, *QA Guidance for Low-level Waste Disposal Facilities*.

The scope of NRC's QA Program for HLW or spent fuel disposal in a geological repository (other than Yucca Mountain) is described in 10 CFR Part 60; specifically Subpart G.<sup>77</sup> The QA program for storage of spent fuel in an ISFSI is described in 10 CFR Part 72. NRC Regulatory Guide 7.10 describes QA programs for packaging for both transport and storage of radioactive material.<sup>78</sup> An additional useful document is NUREG/CR-6314, *Quality Assurance Inspections for Shipping and Storage Containers*.<sup>79</sup>

The QA requirements for the Yucca Mountain project are in 10 CFR Part 63. Section 2.5.1 of NRC's Yucca Mountain Review Plan (NUREG-1804) defines information to be evaluated to determine compliance of DOE's quality assurance program with NRC regulations in 10 CFR Part 63 during review of DOE's License Application for the proposed repository at Yucca Mountain. NRC observes audits conducted by DOE's Office of Quality Assurance. NRC documents its observations of DOE audits and transmits its observations to DOE.<sup>80</sup>

Quality assurance is addressed as part of the license requirements for uranium recovery operations. Areas where quality assurance is particularly important include: disposal cell performance; monitoring, injection, and recovery well construction; and final cover system construction. Typically, technical specifications are developed to provide requirements for materials and construction techniques. A quality assurance, testing, and inspection program including supervision by a qualified engineer or scientist, is established to assure the specifications are met.

The QA requirements for packaging and transportation of licensed radioactive material are provided in Subpart H of 10 CFR Part 71.

### F.3.2 DOE Quality Assurance

Most DOE activities are subject to quality assurance (QA) requirements found in DOE orders and guidance. DOE QA requirements are specified at 10 CFR 830.120. DOE programs must implement the QA criteria to achieve adequate protection of the workers,

---

<sup>77</sup> See <http://www.nrc.gov/reading-rm/doc-collections/cfr/part060> Similar provisions for the QA program found in 10 CFR Part 72 and 10 CFR Part 63 can also be accessed at <http://www.nrc.gov>

<sup>78</sup> Quality Assurance guidance for Part 71 is provided in the Regulatory Guide 7.10, "Establishing Quality Assurance Programs for Packaging Used in Transport of Radioactive Material" Revision Number 2.

<sup>79</sup> See <http://www.nrc.gov/reading-rm/doc-collections/nuregs/contract/cr6314/cr6314.pdf>

<sup>80</sup> See <http://www.nrc.gov/waste/hlw-disposal/quality-audits.html>

the public, and the environment, taking into account the work to be performed and its hazards. They must develop their QA programs by applying ten QA criteria using a graded approach. The ten QA criteria fall within three areas: management, performance, and assessment. The management criteria are QA program, personnel training and qualification, quality improvement, documents and records. The performance criteria are work processes, design, procurement and inspection, and acceptance testing. The assessment criteria are management assessment and independent assessment. The QA program plan must describe how the criteria are satisfied and how the graded approach is applied. DOE performs internal audits and assesses whether its contractors have satisfactorily implemented the DOE quality assurance program.

DOE organizations may impose additional quality requirements or specific standards, as needed, for certain types or work. Some DOE work is subject to regulation by QA requirements from NRC, including the Yucca Mountain repository, NRC-licensed spent fuel storage facilities, and NRC-certified transportation packages.

#### **F.4 Operational Radiation Protection (Article 24)**

The following sections describe radiation protection responsibilities at EPA, NRC, and DOE. The U.S. Government also has access to leading experts in radiation protection through institutions such as the National Academy of Sciences (NAS)/National Research Council and the NCRP (See Section E.2.6). The NAS is a private, nonprofit institution providing science, technology and health policy advice under a Congressional charter. The NAS established a Board on Radioactive Waste Management (now part of the new Nuclear and Radiation Studies Board) focusing on waste management and disposal.

##### **F.4.1 U.S. Environmental Protection Agency**

EPA is responsible for issuing guidance to Federal agencies on radiation protection matters. EPA provides emergency response training and analytical support to state and local and tribal governments and works closely with other national and international radiation protection organizations to further our scientific understanding of radiation risks.

Primary radiation protection regulations for spent fuel management include 40 CFR Part 190, *Environmental Radiation Protection Standards for Nuclear Power Operations*, and 40 CFR Part 191, *Environmental Radiation Protection Standards for Management and Disposal of Spent Nuclear Fuel, High-level and Transuranic Radioactive Wastes*.

Another radiation protection regulation related to 40 CFR Part 191, pertaining to radioactive waste (not spent fuel) management at DOE's Waste Isolation Pilot Plant geologic repository, is found in 40 CFR Part 194, *Criteria for the Certification and Re-certification of the Waste Isolation Pilot Plant's Compliance with 40 CFR Part 191 Disposal Regulations*. See Section E.2.2.1 for additional information.

The *Public Health and Environmental Radiation Protection Standards for Yucca Mountain, Nevada*,<sup>81</sup> promulgated in 40 CFR Part 197 by EPA, became effective on July 13, 2001. EPA was directed to develop these standards by law in Section 801 of the

---

<sup>81</sup>EPA Yucca Mountain Standards, <http://www.epa.gov/radiation/yucca/index.html>

Energy Policy Act of 1992 (EnPA). The EnPA also required EPA to contract with the NAS to conduct a study and provide findings and recommendations on reasonable standards for protection of the public health and safety. The National Academy of Sciences released its report, *Technical Bases for Yucca Mountain Standards*, on August 1, 1995. This report was used by EPA in its development of the Part 197 standards. EPA amended the standards in September 2008 to address provisions that were determined by court ruling not to be consistent with the NAS recommendation regarding the compliance period. See Section E.2.2.2 for additional information.

Federal guidance is a set of guidelines developed by EPA, for use by Federal and state agencies responsible for protecting the public from the harmful effects of radiation. Guidance documents produced by EPA are available on the internet.<sup>82</sup> Some key radiation protection guidance documents are listed in Annex F-2.

#### **F.4.2 NRC General Radiological Protection Limits**

The provisions for general safety for workers and protection of the public during the operational phase of commercial radioactive waste management facilities are addressed in NRC regulations contained in 10 CFR Part 20, *Standards for Protection Against Radiation*. 10 CFR Part 20 includes agency requirements for:

- Dose limits for radiation workers and members of the public;
- Monitoring and labeling radioactive materials;
- Posting radiation areas; and
- Reporting the theft or loss of radioactive material

The provisions in 10 CFR Part 20 also include:

- Penalties for not complying with NRC regulations; and
- Tables of individual radionuclide exposure limits.

NRC regulates commercial nuclear power generation as well as medical, academic, and industrial uses of radioactive material. NRC has published additional regulations addressing reactors, medical uses of isotopes, large irradiators and other commercial uses of radioactive material, in addition to the radiation protection requirements contained in 10 CFR Part 20. NRC is developing regulations and procedures to address its new EPAAct05 responsibilities. NRC promulgates safety regulations expressed in annual total effective dose equivalents (TEDE), as well as air and liquid effluent release concentrations.

##### **F.4.2.1 Occupational Dose Limits**

Operations are conducted so the occupational dose to individual adults complies with an annual limit, which is the more limiting of: (1) The TEDE being equal to 0.05 Sv (5 rems); or (2) The sum of the deep-dose equivalent and the committed dose equivalent to any individual organ or tissue other than the lens of the eye being equal to 0.5 Sv (50 rems). Annual occupational dose limits are established at 10 CFR 20.1201 for adults and §20.1207 for minors.

---

<sup>82</sup>EPA Radiation Protection Program, <http://www.epa.gov/radiation/federal/index.html>

There are other specific conditions, such as for planned special exposures and specific organ limits, as well as considerations for a soluble uranium chemical toxicity intake limit of 10 milligrams in a week. NRC's limit of 10 mg/week for soluble uranium is contained at 10 CFR 20.1201(e), and is based on the onset of heavy metal poisoning to the kidney. This limit is further addressed in footnote 3 of Appendix B to Part 20. Dose limits for a fetus are contained at 10 CFR 20.1208 and are applicable only for a "declared pregnant woman," which is defined at 10 CFR 20.1003. The dose to an embryo/fetus as a result of occupational exposure should be as low as reasonably achievable (ALARA) and should not exceed 5 mSv (0.5 rem) during the entire gestation period. Figure F-1 provides historical TEDEs for ISFSIs over a 20 year period.<sup>83</sup>

NRC maintains the Radiation Exposure Information and Reporting System (REIRS) for Radiation Workers, which provides the latest available information on radiation exposure to the workforce at certain NRC licensed facilities. It also contains information concerning the recording and reporting requirements of NRC licensees. This information and other details on occupational exposure are available on the internet and updated annually.<sup>84</sup>

#### **F.4.2.2 Public Dose Limits**

Operations must be conducted so the TEDE to individual members of the public from the licensed operation does not exceed 1 mSv (100 mrem) in a year for release to unrestricted areas and protection of the public. This dose limit is exclusive of the contributions from background radiation, any medical administration to individuals, and other contributions not attributable to the licensed operation. However, ALARA considerations can result in dose constraints on the order of 0.10 to 0.25 mSv (10 to 25 mrem).

There are provisions where an individual member of the public may be exposed to higher levels. The dose limits in 10 CFR Part 20 include consideration of both internal and external doses. Specific reporting requirements are contained in Subpart M of Part 20.

The dose levels associated with disposal of radioactive wastes and for the release of facilities used for licensed activities are also contained in Part 20 (e.g., 20.1402, 20.1403, and Subpart K), and include requirements for surveys and measurements for residual radioactivity. Solid materials can be released for unrestricted use if the survey or measurement does not detect residual radioactivity from the licensed operations, or if it does detect residual radioactivity, the amount is below a level considered to be protective of the public health and safety and the environment.

Subpart B of 10 CFR Part 20 provides NRC's regulatory requirements for Radiation Protection Programs, and includes the requirements for licensees to establish programs for ALARA. These requirements specifically address the release of radioactive effluents to the environment.

---

<sup>83</sup>This document is published as: NUREG-0713, *Occupational Radiation Exposure at Commercial Nuclear Power Reactors and Other Facilities* 2006, Vol. 28, U.S. Nuclear Regulatory Commission, November 2007, available at <http://www.reirs.com/nureg2006/nureg2006.pdf>

<sup>84</sup> NRC's Radiation Exposure Information and Reporting System (REIRS) for Radiation Workers is accessible at <http://www.reirs.com>.

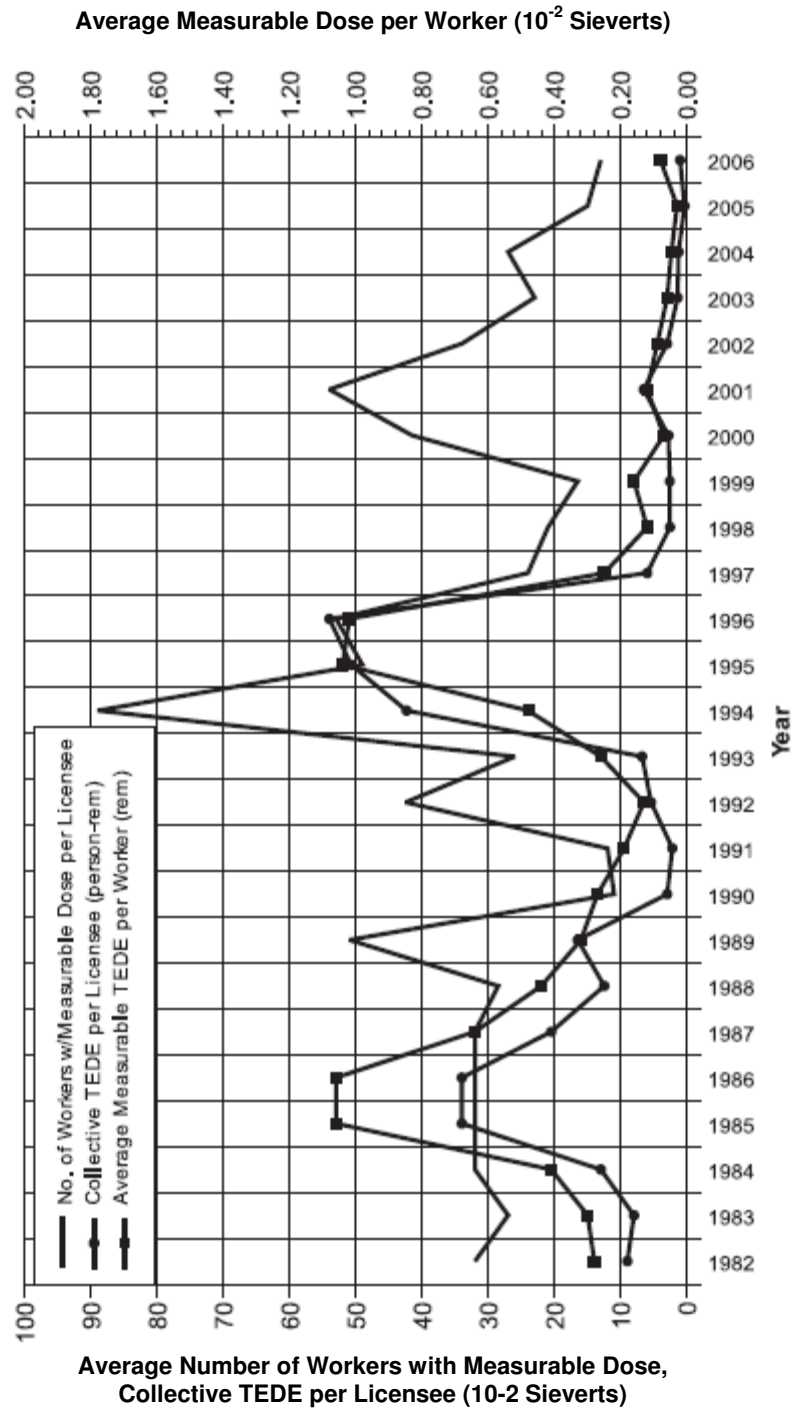

Figure F-1 Average Annual Values at Independent Spent Fuel Storage Facilities, 1982-2006

#### **F.4.2.3 Radiological Criteria for License Termination (Decommissioning)**

For protection of the public, dose-based requirements for licensees seeking license termination are found in 10 CFR 20, Subpart E. These regulations establish two final states for licensee termination: unrestricted use and restricted use. In addition to the specific limits for each state, NRC requires licensees to maintain ALARA doses. This means the licensee must make every reasonable effort to reduce the dose as far below the specified limits as is practical, taking into account the state of technology and economics (see 10 CFR 20.1003). For the case of unrestricted release, residual radioactivity distinguishable from background shall not result in a calculated dose from all pathways to the average member of the critical group exceeding 0.25 mSv/a (25 mrem/yr). This includes contribution from groundwater sources of drinking water. The basic requirement for license termination under restricted conditions is that the licensee provides institutional controls that limit the calculated dose to 0.25 mSv/a (25 mrem/yr). Further, the licensee must reduce residual radioactivity so that if these controls fail, the calculated dose would not exceed 1 mSv/a (100 mrem/yr). Additional considerations apply in the case of restricted release, and there are provisions for use of alternative criteria; additional details are available from NRC's website.<sup>85</sup>

#### **F.4.2.4 LLW Disposal Sites**

Protection of the general population from releases of radioactivity from a LLW disposal facility is also dose-based. The concentrations of radioactive material to the general environment in ground water, surface water, air, soil, plants, or animals must not result in an annual dose exceeding an equivalent of 0.25 mSv/a (25 mrem/yr) to the whole body, 0.75 mSv/a (75 mrem/yr) to the thyroid, and 0.25 mSv/a (25 mrem/yr) to any other organ of any member of the public. NRC policy is to apply the 25/75/25 mrem dose constraint as a TEDE of 25 mrem. Reasonable efforts should be made to maintain releases of radioactivity in effluents to the general environment ALARA.

#### **F.4.2.5 Uranium Mill Tailings Disposal Sites**

Reclaimed uranium mills are required to meet a radon release constraint in 10 CFR Part 40, Appendix A in addition to the annual dose limits described in the previous section. There is a radon (<sup>222</sup>Rn from uranium byproduct materials and <sup>220</sup>Rn from thorium byproduct materials) flux limit for a stabilized mill tailings disposal site of 0.7 Bq/m<sup>2</sup>-s (20 pCi/ m<sup>2</sup>-s). The 0.7 Bq/m<sup>2</sup>-s radon release from uranium mill tailings was based on the cost-effectiveness of control for a thick earthen cover design, taking into consideration individual and population doses. There are also groundwater concentration limits for radionuclides and certain hazardous constituents. A design must provide reasonable assurance of control of radiological hazards to be effective for 1,000 years, to the extent reasonably achievable, and, in any case, for at least 200 years. This design must also inhibit misuse of tailings, stabilize the tailings against erosion and contamination of land and water, minimize gamma radiation exposure, and avoid ground water contamination.

---

<sup>85</sup> See <http://www.nrc.gov/reading-rm/doc-collections/cfr/part020/full-text.html#part020-1404>

### F.4.3 DOE Radiation Protection Regulations

DOE requires radiation protection for workers and the public in its regulations and directives. 10 CFR Part 835 governs radiation protection of workers at DOE facilities and activities not licensed by NRC. DOE regulations in 10 CFR Part 835 are similar to NRC regulations in 10 CFR Part 20, but there are some differences resulting from the types of radiological activities regulated by DOE and NRC, respectively.

DOE occupational radiation protection requirements emphasize contamination control and internal dose monitoring because DOE operates facilities involved in weapons production. 10 CFR Part 835 specifies warning signs specifically for contamination areas, contains a table of surface contamination values, and requires the use of bioassay data instead of air sampling data for internal dose estimation in most cases. Further directives are found in DOE Order 5400.5, *Radiation Protection of the Public and the Environment*.

There is no time limit on the applicability of DOE's radiation protection criteria. DOE considers whether risks may eventually be low enough so continued protection would not be needed. DOE, or successor agencies, may be required in some cases, to maintain control because of the nature of the hazard and statutory requirements.

Compliance with these regulations is generally determined by inspectors using survey equipment to measure radionuclide airborne or liquid concentrations within and at control boundaries. These concentrations are determined to be representative of TEDEs or of effective doses corresponding to individuals exposed to such concentrations.

Safety assessment computer models are used to forecast exposures, prior to operating a nuclear facility, including spent fuel storage and radioactive waste disposal on a predictive basis. The concentrations and doses predicted by modeling a range of potential scenarios are then compared to dose and concentration limits in the applicable Federal regulations and DOE orders and manuals. Such assessments support a risk-informed operational, closure and post-closure monitoring strategy in order to provide an effective measure of performance.

DOE estimates radiation doses to the public around its many sites through extensive continuous radiological monitoring and surveillance programs as part of its commitment to communities where its facilities are located. The offsite individual doses remain well below DOE and EPA NESHAPs compliance limits. The estimated annual collective dose to the public from all DOE activities continues to decrease because of cleanup, stabilization, and closure of contaminated sites. Background radiation dose to the population in a large metropolitan area would be more than 20,000 person-Sv (two million person-rem) annually, from natural and man-made sources to put the estimated DOE-wide annual collective dose in perspective. Figure F-2 shows the historical trend.

DOE keeps radiation exposures to workers ALARA (as low as is reasonably achievable) within the constraints imposed by work, equipment, and technical conditions. The ALARA concept is accomplished through work planning considering a worker's time in the area, distance from the work, and required shielding. Workers are monitored for radiological skin contamination, exposures, and uptakes. Administrative control levels are established to manage exposures to workers so no one exceeds these levels without



prior approval. The annual limit for a worker is 50 mSv (5 rem). No individuals exceeded the 50 mSv (5 rem) annual limit in 2004 to 2006. Only 14 percent (12,953 out of 91,280) of DOE workers monitored for radiation dose received a measurable dose in 2006. In 2006, the average annual measurable dose to a worker was 0.63 mSv (63 mrem), and the collective dose was 8.13 person-Sv (813 person-rem). This represents the third straight year of significant decline; over 40 percent reduction from 2003. The decrease is due primarily to decreases in work performed directly involving radioactive materials. Several facilities completed cleanup operations and no longer contribute to worker exposure. One of the most important reasons for dose reduction was the Rocky Flats closure. All cleanup operations at Rocky Flats were completed in 2005, and therefore do not contribute to DOE collective dose in 2006.

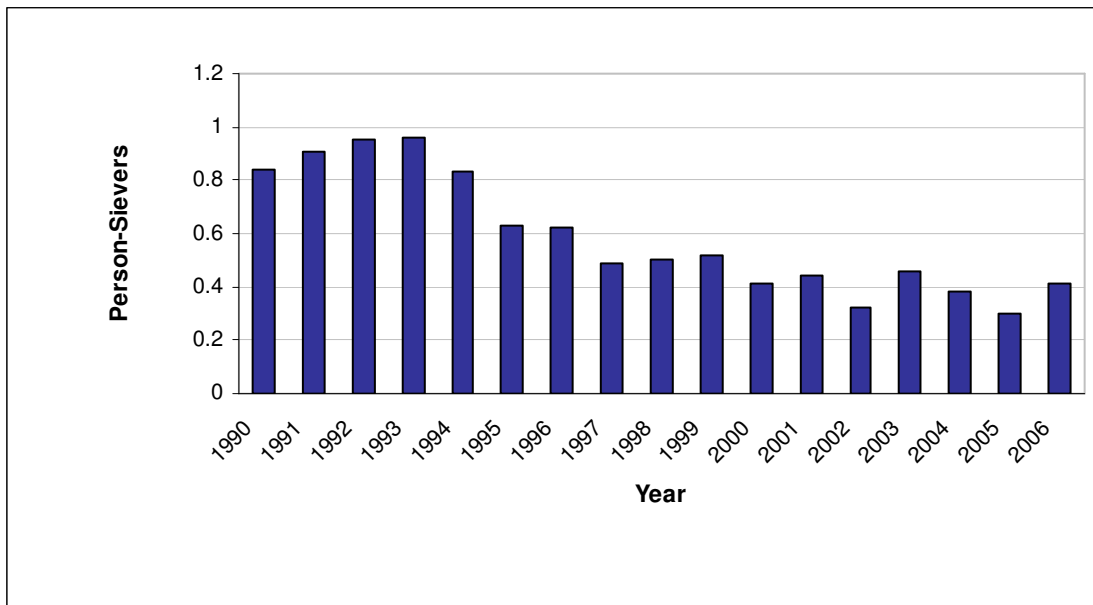

Figure F-2 Estimated Off-Site Radiation Dose to the Public

The average American receives approximately 3 mSv (300 mrem/yr) from natural sources of radiation and 360 mrem/yr including man-made sources to place DOE dose in perspective.<sup>86</sup> The majority of those workers with a measurable dose in 2003 (13,865 out of 17,484) received less than 1 mSv (100 mrem) total effective dose equivalent. Thousands of people work in radiation areas every day without receiving significant radiation exposure, which may be attributable to the effectiveness of ALARA controls.

<sup>86</sup> Source: *Ionizing Radiation Exposure of the Population of the United States*, National Council on Radiation Protection and Measurements Report No. 93, 1987. NCRP is currently re-evaluating background radiation exposures, so these figures are subject to change. Preliminary findings discussed at the 2007 NCRP Annual meeting indicate that average annual individual medical exposures will increase by roughly a factor of 6 (from about 0.5 mSv to 3.2 mSv per year), primarily resulting from the increased use of imaging techniques.

#### **F.4.4 Other Radiation Protection Regulations**

EPA has the prime role in setting U.S. radiation protection standards that are implemented by NRC, DOE and other Federal agencies:

- The Occupational Health & Safety Administration of the Department of Labor (DOL) has regulations dealing with worker protection from ionizing radiation found in 29 CFR; and
- The Mine Safety and Health Administration of the DOL has safety and health regulations related to underground mining in 30 CFR Part 57, subparts 4037 to 5047.

Limits for air and water discharges from spent fuel/radioactive waste facilities are established through rulemaking by the responsible agency. EPA has issued rules for spent nuclear fuel, high-level radioactive waste, TRU waste, commercial nuclear fuel cycle and uranium/thorium mill tailings facilities. See EPA's responsibilities throughout Section E.

NRC implements these rules and has established rules for commercially generated low-level radioactive waste facilities except for TRU waste. DOE regulates air and water discharges from its radioactive waste facilities through its internal orders, while airborne emissions from DOE facilities are regulated by EPA.

Many states have comprehensive radiation control programs. These programs, for example, may regulate the use of diagnostic and therapeutic x-ray equipment and certain radioactive materials or conduct environmental monitoring.

#### **F.5 Emergency Preparedness (Article 25)**

Article 25 specifies spent fuel and radioactive waste management facilities must have appropriate on-site and, if necessary, off-site emergency plans, and should be tested at an appropriate frequency. Additionally, Article 25 requires each Contracting Party to prepare and test emergency plans on its territory in the event of a radiological emergency at a spent fuel or radioactive waste management facility in the vicinity of its territory. The following subsections describe the extensive emergency preparedness and emergency management programs in place at NRC-licensed and DOE facilities.

##### **F.5.1 Emergency Preparedness within NRC**

###### **F.5.1.1 Nuclear Facility Response Plans**

NRC regulations require comprehensive emergency plans be prepared and periodically exercised to assure actions are taken to notify and protect citizens in the vicinity of a nuclear facility during an emergency. Although nuclear power plants, as well as fuel fabrication and uranium conversion and enrichment facilities, have active components potentially requiring immediate protective response to mitigate the effects of an accident, radioactive waste disposal systems are passive. For radioactive waste management and spent fuel management at a nuclear power plant or other significant nuclear fuel cycle facility, the emergency preparedness program is modified by license condition

upon the facility's entry into the decommissioning phase. The revised provisions for emergency preparedness and response will be modified commensurate with the hazard of the materials remaining within the former controlled areas.

NRC Regulatory Guide 3.67<sup>87</sup> provides information on the classification of emergencies as either "alerts" or "general site emergencies" for general materials facilities. Categories of emergencies are identified in Annex F-3. DOE also has published classification guidance in DOE G151.1-1, *Categorization and Classification of Operational Emergencies*.<sup>88</sup>

NRC reevaluated the emergency preparedness for nuclear fuel cycle facilities after a large, toxic release of uranium hexafluoride (UF<sub>6</sub>) at the Sequoyah Fuels Corporation conversion facility in 1986. Significant potential accidents at uranium conversion, fuel fabrication, and enrichment facilities include UF<sub>6</sub> releases, fires, and criticality accidents; the latter being an unintended, self-sustaining nuclear chain reaction. In addition to UF<sub>6</sub> releases, there may be releases of other chemicals produced by, or used in fuel processing. These may include hydrofluoric acid, nitric acid, and other hazardous chemicals.

Although the severity and extent of hazards associated with spent fuel or radioactive waste management facilities are different than those associated with a nuclear power plant, many of the elements for emergency response are still applicable. The same is true for an incident involving sealed sources, disused or otherwise.

NRC does not have plans to change the emergency classification system for commercial nuclear power plants. NRC does not directly require a "General Emergency" category for non-reactor Fuel Cycle Facilities and other materials facilities. The Emergency Planning and Community Right-to-Know Act (EPCRA), requires off-site "general emergency" planning for facilities possessing hazardous chemicals (including toxic uranium) on-site. NRC simply requires certification that these requirements have been met. It should also be noted "General Emergency" planning (for off-site areas) is much broader in scope, detail, complexity and politics than "Site Area" emergency planning.

#### **F.5.1.2 NRC Response to an Emergency**

NRC activates its incident response program at its Headquarters Operations Center and one of its four Regional Incident Response Centers (Region I in King of Prussia, Pennsylvania; Region II in Atlanta, Georgia; Region III, in Lisle, Illinois; and Region IV in Arlington, Texas) in response to an event at an NRC-licensed facility potentially threatening public health and safety, or the environment. NRC's highest priority is to provide expert consultation, support, and assistance to state and local public safety officials responding to the event. Teams of specialists are assembled at the Headquarters Operations Center and Regional Incident Response Center to obtain and evaluate event information and to assess the potential impact of the event on public health and safety and the environment once NRC's incident response program is activated. Scientists and engineers analyze the event and evaluate possible recovery strategies. Other experts evaluate the effectiveness of protective actions recommended by the licensee and implemented by state and local officials to minimize the impact on

---

<sup>87</sup> See <http://www.nrc.gov/reading-rm/doc-collections/reg-guides/fuels-materials/active/03-067/index.html>

<sup>88</sup> See <http://www.directives.doe.gov/>.

public health and safety and the environment. Communications with the news media, state, other Federal agencies, the Congress, and the White House are coordinated through the Headquarters Operations Center.

NRC's role, as well as the roles of other Federal agencies in the coordinated emergency response to a nuclear accident, is described in the Nuclear/Radiological Incident Annex of the National Response Plan.<sup>89</sup> NRC will immediately dispatch a team of experts from the Regional Office to the site if event conditions warrant.

### **F.5.1.3 NRC Emergency Response Exercises**

NRC Headquarters and Regional staff members typically participate in several emergency response exercises each year for materials facilities. This is in addition to participation in four full scale emergency exercises for nuclear power plants, as well as participation in several multi-agency exercises. Annex F-4 provides a list of the exercises in which NRC participated in 2005–2007. Annexes F-3 through F-6 discuss in more detail the emergency measures, requirements and additional references addressing emergency response.

### **F.5.1.4 Incident Investigation and Event Reporting**

Incident investigation is a formal process conducted to help prevent accidents. NRC's Incident Investigation program provides a formal, structured, and appropriately measured NRC investigative response to significant operational events based on their safety significance. This process includes gathering and analyzing information; determining findings and conclusions, including the causes of a significant operational event; and publishing the investigation results for NRC, industry, and public review.

The types of NRC incident investigations include:

- Establishing an Incident Investigation Team, by NRC Executive Director for Operations, for events of potentially major safety significance;
- Establishing an Augmented Inspection Team, by senior NRC management, for events of lesser safety significance; and
- Establishing a Special Inspection Team, reporting directly to the appropriate regional administrator, that focuses on a specific issue at all or a group of facilities.

NRC's Incident Investigation program, outlined in Management Directive 8.3, *NRC Incident Investigation Program*, ensures the investigation of significant events is performed in a timely, objective, systematic, technically sound, and independent way by NRC staff associated with the licensing and inspection of the affected facility. Factual information about the event and probable cause(s) must also be documented.

A senior NRC manager reporting directly to NRC Executive Director for Operations leads the Incident Investigation Team. The team is technically and administratively supported by the Office of Nuclear Security & Incident Response.

---

<sup>89</sup> See [http://www.dhs.gov/interweb/assetlibrary/NRP\\_FullText.pdf](http://www.dhs.gov/interweb/assetlibrary/NRP_FullText.pdf) for more detail.

Annex F-5 provides a list of investigation reports for non-reactor incidents and the requirements under which such reports are made. Annex F-5 also provides links to additional Information on response to incidents.

#### **F.5.1.5 Emergency Preparedness at Radioactive Materials Facilities**

NRC regulations in 10 CFR Part 30, *Rules of General Applicability to Domestic Licensing of Byproduct Material*; 10 CFR Part 40, *Domestic Licensing of Source Material*; and 10 CFR Part 70, *Domestic Licensing of Special Nuclear Material*, require some fuel cycle and materials licensees to prepare emergency plans. These emergency plans are required to comply with the requirements of 10 CFR 30.32(i)(3), 10 CFR 40.31(j)(3), or 10 CFR 70.22(i)(3). Generally, the types of information to be submitted in these emergency plans include: facility description, types of accidents, classification and notification of accidents, detection of accidents, mitigation of consequences, assessment of releases, responsibilities, notification and coordination, information to be communicated, training, safe shutdown, exercises, and hazardous chemicals.

NRC performed a regulatory analysis on emergency preparedness for nuclear fuel cycle facilities and other radioactive material licensees in 1988.<sup>90</sup> The analysis addressed uranium mining and milling, UF<sub>6</sub> conversion plants, enrichment plants, fuel fabrication, spent fuel storage, new fuel storage, reprocessing and research. In terms of byproduct material facilities such as radiopharmaceutical operations, sealed source manufacturing, depleted uranium production and waste warehousing and burial were considered. The study concluded accidents at these types of facilities pose a very small risk to the public. Serious accidents are infrequent and would generally involve relatively small radiation doses to a few people located in limited areas. The costs for extraordinary precautions were not justified.

The most potentially hazardous accident, by a large margin, was determined to be the sudden rupture of a heated multi-ton cylinder of UF<sub>6</sub>. The most critical injury would be from the chemical toxicity; the accompanying radiation doses would not be significant. Prevention would be the best strategy, because – in most instances – actions taken 30 minutes after accident detection would be mostly ineffective. The most effective approach to emergency response would be a simple approach consisting of:

- Identification of accidents where protective actions should be taken off site;
- Listing the licensee's responsibilities for each type of accident, including notification of local authorities (e.g., fire and police); and
- Providing sample messages for local authorities including protective action recommendations.

Specific thematic information on emergency preparedness and planning for specific waste management facility types is summarized in Annex F-6 for geologic, near surface, uranium mills, and decommissioning.

---

<sup>90</sup>The findings for this analysis were published in NUREG-1140, *A Regulatory Analysis on Emergency Preparedness for Fuel Cycle and Other Radioactive Material Licensees*.

## **F.5.2 Emergency Preparedness and Management within DOE**

DOE has implemented an emergency management system for all its sites and facilities. DOE Order 151.1, *Comprehensive Emergency Management System*, describes DOE's emergency management system, by establishing policy; assigning roles and responsibilities; and providing the framework for development, coordination, control, and direction. This order establishes requirements for emergency planning, preparedness, response, recovery, and readiness assurance activities and describes the approach for effectively integrating these activities under a comprehensive, all-emergency concept. DOE facilities, sites, or activities and organization offices are required to develop emergency management programs as elements of DOE's comprehensive emergency management system. The pieces of the system are integrated to ensure DOE is prepared to respond promptly, efficiently, and effectively to any emergency involving DOE, including events at spent fuel and radioactive waste management facilities, to protect workers, the public, the environment, and national security.

DOE's Emergency Management Guide (DOE Guide 151.1-1) provides an acceptable approach for implementing the requirements and expectations of Order 151.1. DOE Order 151.1 discusses 14 emergency management programmatic elements of a comprehensive system of emergency management, for example, hazards survey and hazards assessment, emergency response organization, notifications and communications, emergency public information, and exercises. The Emergency Management Guide discusses each of these elements in detail.

DOE's approach to emergency management is composed of a three-tiered management structure consisting of facilities and sites, DOE field organization offices, and DOE headquarters. The facility or site level manages the tactical response to the emergency by directing actions necessary to resolve the problem, protect the workers, the public and the environment and return the facility to a safe condition. DOE's field organization office oversees the facility response and provides assistance and guidance to the facility management. The Headquarters organization provides strategic direction to the response, provides assistance and guidance to the field organization, evaluates impacts to the larger DOE complex, and coordinates with other Federal governmental agencies and branches and the national media.

Because there is a wide variety of hazards considered, the emergency management program for a facility must be commensurate with the hazards present at a facility or site. This is often referred to as a tailored or graded approach. Each facility is required to have an operational emergency base program. The objective of the base program is to achieve an effective integration of emergency planning and preparedness requirements into an emergency management program providing capabilities for all-emergency response, through communication, coordination, and an efficient and effective use of resources. A hazards assessment is required for each facility or site where hazardous materials are present in quantities exceeding specified thresholds. The hazards assessment results determine whether an operational emergency hazardous materials program is required on top of the foundation of the base program.

Requirements in DOE Order 151.1 specify an operational emergency be declared when events or conditions at a DOE facility or site require response outside the immediate/affected facility, site, or area of the event. This is the process of categorizing an event or condition as an operational emergency. Such events or conditions cause, or

have the potential to cause: serious health and safety impacts to workers or the public, serious detrimental effects on the environment, direct harm to people or the environment as a result of degradation of security or safeguards conditions, or loss of control over hazardous materials.

Operational emergency events or conditions involving loss of control over hazardous materials (including radioactive materials) are classified based on the severity of potential consequences at a specific distance from the source of the release. Classes include alert, site area emergency, or general emergency, in order of increasing severity. This classification scheme facilitates early decision-making particularly with respect to response activities, off-site notifications, and protective actions, by making decisions during planning rather than during actual response.

DOE's emergency management programs are subject to periodic independent assessments by DOE Office of Emergency Management Oversight. This Office conducts regular independent assessments of DOE emergency management policies and programs at DOE sites having significant hazards and follow-up reviews to ensure corrective actions are effective. The Office also conducts complex-wide studies of issues and generic weaknesses in emergency management programs.

Programs are evaluated against the requirements and guidance found in various documents, including DOE Order 151.1, the associated emergency management guide, and appraisal process protocols. The inspectors develop lines of inquiry using these guidance documents applicable to their assigned program element to guide field activities. Another reference providing information for evaluating DOE emergency management programs is DOE Order 470.2, *Independent Oversight and Performance Assurance Program*. DOE Order 470.2 describes the basis and purpose of oversight activities and specifies requirements for reviewing and commenting on appraisal reports and developing corrective action plans.

## **F.6 Decommissioning Practices (Article 26)**

Both NRC and DOE have active decommissioning programs as discussed in Section D.3. Their approaches are discussed in the following subsections.

### **F.6.1 NRC Decommissioning Approach**

NRC regulates the decontamination and decommissioning of nuclear facilities with the ultimate goal of license termination. NRC regulations assign responsibility for decommissioning licensed and unlicensed facilities to the licensee or other responsible parties. NRC evaluates the licensee's or responsible party's proposed decommissioning plan, including the licensee's justification for using a particular remediation methodology, to determine if it is appropriate for the specific decommissioning project. The decommissioning process consists of a series of integrated activities, beginning with the facility in transition from "active" to "decommissioning" status and concluding with the termination of the license and release of the site. Decommissioning may be relatively simple and straightforward or complex.

### F.6.1.1 Nuclear Reactor Facilities

When a power reactor licensee has decided to permanently cease operations, the licensee must, within 30 days, submit written certification to NRC. Prior to, or within two years after permanent cessation of operations, the licensee must submit a post-shutdown decommissioning activities report (PSDAR) to NRC. Licensees shall not perform any major decommissioning activities until 90 days after NRC receives the PSDAR, and until certifications of permanent cessation of operations and permanent removal of fuel from the reactor vessel have been submitted to NRC. Licensees may undertake non-major decommissioning activities upon permanent cessation of operations. The PSDAR is then made available to the public and a public meeting held near the plant. The report provides a description of the licensee's planned decommissioning activities, a schedule of significant milestones, and an estimate of the expected costs, and documentation of considered environmental impacts. NUREG-1700, Revision 1, *Standard Review Plan for Evaluating Nuclear Power Reactor License Termination Plans* describes the information requirements for a License Termination Plan.

A License Termination Plan is submitted at least two years before license termination and addresses detailed plans for meeting final site residual radioactivity criteria, site characterization and remediation plans, estimates of remaining costs, and any new information. Before approval of the plan, an opportunity for a hearing is published and a public meeting is held near the facility.

Reactor licensees may choose one of the following methods for decommissioning their plants:

- DECON (immediate dismantlement), soon after the nuclear facility closes, equipment, structures, and portions of the facility containing radioactive contaminants are removed or decontaminated to a level permitting release (consistent with 10 CFR Part 20, Subpart E) of the property and termination of NRC license; and
- SAFSTOR, a nuclear facility is maintained and monitored in a condition allowing the radioactivity to decay, and is later dismantled.

The choice of decommissioning method (SAFSTOR vs. DECON) is left entirely to the licensee. Either method is legally acceptable. NRC, however, requires the licensee to re-evaluate its decision if its chosen decommissioning method (1) could not be completed as described; (2) could not be completed within 60 years of the permanent cessation of plant operations; (3) included activities endangering the health and safety of the public by being outside of NRC's health and safety regulations; or (4) would result in a significant impact to the environment.

Licensees are not restricted to solely a SAFSTOR or DECON approach. Licensees can combine the SAFSTOR and DECON options. Licensees can use a short storage period for planning purposes, then remove the large components (such as steam generators, pressurizer, and reactor vessel internals), place the facility in storage for 30 years, and then finish the decontamination and dismantlement process. Current regulations require decommissioning be completed within 60 years. Additional time will be considered only when necessary to protect public health and safety.



Spent fuel could remain stored in the spent fuel pool or in dry cask storage facilities until a geologic repository is built and operating. The regulations also require the ISFSI be designed for decommissioning. Provisions must be made to facilitate decontamination of structures and equipment, minimize the quantity of radioactive wastes and contaminated equipment, and facilitate the removal of radioactive wastes and contaminated materials when the ISFSI is permanently decommissioned.

Decommissioning is also accounted for in NRC's design criteria for construction of a geologic repository for high level waste. NRC regulations at 10 CFR 60.132(e) require the surface facilities in the geologic repository operations area be designed to facilitate decontamination or dismantlement. DOE is required to submit plans for Yucca Mountain repository permanent closure, as well as plans for decontaminating, decommissioning, and dismantling surface facilities, as part of its Safety Analysis Report supporting the license application [10 CFR 63.21(c)(22)(vi)].

### **F.6.1.2 Materials Facilities and Activities**

Material facilities decommissioning activities include maintaining regulatory oversight of complex decommissioning sites; conducting inspections; interacting with the affected public; undertaking financial assurance reviews; and coordinating with other partner Federal agencies.

Any of the following conditions can initiate the decommissioning process:

- The license expires;
- The licensee has decided to permanently cease principal activities at the entire site or in any separate building or outdoor area;
- No principal activities have been conducted for a period of 24 months; or
- No principal activities have been conducted for a period of 24 months in any separate building or outdoor area.

Several major steps make up the decommissioning process: notification, submittal and review of the DP, implementation of the DP, and completion of decommissioning. Within 60 days of the occurrence of any of the triggering conditions, the licensee or other responsible party is required to notify NRC of such occurrence and either begin decommissioning or, if required, submit a DP within 12 months of notification and begin decommissioning after approval of the plan. Alternative schedules are authorized under the regulations, with NRC approval. A DP must be submitted if required by license condition or if the procedures and activities necessary to decommission have not been previously approved by NRC and the procedures could increase potential health and safety impacts on workers or the public.

In the case that the licensee or other responsible party proposes restricted release, the review of the DP will be conducted in two phases. The first phase of the review will focus on the financial assurance (FA) and institutional control (IC) provisions of the DP. The review of the remainder of the DP will be initiated only after the staff is satisfied that the licensee's proposed IC & FA provisions will comply with the requirements of the License Termination Rule (LTR) (Part 20, Subpart E).

The staff's review is guided by NUREG-1757, *Consolidated Decommissioning Guidance*, where NRC has consolidated its decommissioning guidance for materials sites into a more risk-informed and performance-based document. This consolidation was performed to incorporate over 80 decommissioning guidance documents into NUREG-1757, published in 3 volumes. These volumes address: (1) Decommissioning Process for Materials Licensees, (2) Characterization, Survey, and Determination of Radiological Criteria; and (3) Financial Assurance, Recordkeeping, and Timeliness. This NUREG report provides NRC staff and nuclear material licensees with a single reference guidance document. The staff periodically updates NUREG-1757, so that it reflects current NRC decommissioning policy. In September 2006, the staff issued updates Volumes 1 and 2 of NUREG-1757. The new and revised decommissioning guidance addresses some issues with implementation of the License Termination Rule. NRC is working on a rulemaking to prevent future legacy sites, and plans to update Volume 3 of NUREG-1757, addressing financial assurance, recordkeeping, and decommissioning timeliness.

After NRC approval of the DP, the licensee must complete decommissioning in accordance with the approved DP within 24 months or apply for an alternate schedule. NRC staff will inspect the facility during decommissioning operations to ensure compliance with the DP. These inspections will normally include in-process and confirmatory radiological surveys. As the final step in decommissioning, the licensee is required to take certain steps: (1) certify the proper disposition of all licensed material (including accumulated wastes); (2) conduct a radiation survey of the premises where licensed activities were carried out and submit a Final Status Survey Report (FSSR) of the results (unless the licensee demonstrates in some other manner that the premises are suitable for release in accordance with the LTR); (3) justify that a reasonable effort has been made to eliminate residual radioactive contamination -if present; and (4) demonstrate that the premises are suitable for release in accordance with the LTR.

Low level waste from decommissioning is disposed at a licensed LLW disposal facility after components and materials are dismantled and decontaminated. Other waste with sufficiently low concentrations of radionuclides e.g., building rubble, can be disposed of by alternate methods. See Section H.1.4.

## **F.6.2 DOE Decommissioning Approach**

DOE's management approach to disposing of excess DOE facilities is described in DOE Order 413.3A, *Program and Project Management for the Acquisition of Capital Assets*, with the technical approaches described in Order 430.1B, *Real Property Asset Management*. DOE requires all new facilities with an estimated capital cost in excess of \$5 million be evaluated on a "life cycle" basis, explicitly including decommissioning. DOE has amassed considerable experience in decommissioning. The phases generally involved in excess facility disposition encompass transition, deactivation, surveillance and maintenance, and decommissioning. It is important to note that based on facility/project specific conditions and external factors such as fiscal and schedule considerations, these "phases" are conducted separately or combined in various configurations to optimize the work.

Period 1. Operations. Operations are characterized by an operating or shut down facility under the control of a program other than the program responsible for decommissioning.

It is declared excess and a candidate for transfer once the program establishes there is no further need for the facility.

Period 2. Transition. Transition occurs between operations and disposition in a facility lifecycle. Transition begins once a facility has been declared or forecast to be excess to current and future needs. Transition includes placing the facility in stable and known conditions, identifying hazards and characterizing the facility conditions, eliminating or mitigating hazards and conducting stabilization, and transferring programmatic and financial responsibilities from the operating program to the disposition program. System and infrastructure stabilization activities are initiated prior to the end of facility operations in preparation for disposition. Materials requiring special handling (e.g., classified equipment or nuclear materials) are removed at shutdown where possible. During transition, a determination is made as to whether the facility will be either deactivated for reuse, deactivated in preparation for eventual decommissioning (decontamination and/or dismantling), or decommissioned immediately. The organization responsible for follow-on activities must be involved in this determination. An operational campaign may be required to establish stabilized conditions for some facilities before proceeding to final shutdown. Examples include: (1) a run to process a large quantity of highly radioactive or chemically reactive liquids for cleaning a process system, and (2) removal of nuclear fuel so an area can be made accessible. The use of personnel with operational knowledge and experience is essential during transition.

Period 3. Deactivation. Surveillance and maintenance continues during this period to assure public, environment, and worker safety. As deactivation proceeds, unneeded systems within the facility are terminated, additional hazard reduction may be conducted, and the surveillance and maintenance burden decreases commensurate with achieved risk reduction, resulting in a stable, low risk condition, which is economically and technically practical to maintain for an extended period. Updates of safety documentation to reduce a nuclear facility's hazard classification are of value to post-deactivation surveillance and maintenance. Activities during this period include, for example, disposal of remaining hazardous chemicals, isolation of systems and equipment, and removal of valuable excess equipment. Appropriate characterization and documentation are conducted for remaining contamination and waste, and for other sensitive materials unable to be removed (chemical, hazardous, radioactive, fissile, nuclear fuel, special nuclear, and other accountable materials). This is to support safety updates, specifying deactivation end points, and planning post-deactivation surveillance and maintenance.

Period 4. Post-Deactivation Surveillance and Maintenance. The facility is in a safe storage mode, with ongoing, low levels of surveillance and maintenance. The facility is generally unoccupied and locked except for periodic inspections. If the period between completion of deactivation and beginning of decommissioning becomes extended, an occasional need for refurbishment or repair may be needed; for example, roof repairs, exhaust fan replacement, surveillance instrumentation maintenance, etc. Radioactive and hazardous materials may remain in the facility and are subject to ongoing regulatory oversight.

Period 5. Decommissioning. Decommissioning and ultimate disposition, including options for entombment (*in situ* decommissioning) of a facility will be scheduled in accordance with an overall national priority based on resources.

Most DOE facilities are not licensed by NRC, but all activities by or on behalf of DOE, including decommissioning, are subject to DOE orders and regulations, independent recommendations, and enforcement (Section E.2.3). Decommissioning projects are managed similar to construction projects, requiring multiple critical management decisions during the process leading up to approval to start decommissioning operations. In addition to approval of all the design and procurement activities, other activities feeding into the final decision process include development of decommissioning plans, safety documentation, and environmental assessments, and coordination with local and state governments. Independent reviews of project baseline activities also occur prior to a final decision. DOE decommissioning activities have the financial assurance of the U.S. government.

The regulatory process for decommissioning varies depending upon the specific activity. Additional information on waste management from cleanup of past practice sites is in Section H.2.1.

## **F.7 General Safety Requirements (Articles 4 and 11)**

The United States is fully compliant with the General Safety Requirements found in Article 4 and 11. General safety requirements addressed in the subsections below were called out specifically in the report preparation guidance.<sup>91</sup>

### **F.7.1 Criticality Control and Removal of Residual Heat**

#### **F.7.1.1 Criticality Control**

The American Nuclear Society Standards Subcommittee 8 (ANS-8), *Operations with Fissionable Materials Outside Reactors* has developed national standards for the prevention and mitigation of criticality accidents during handling, processing, storing, and transporting special nuclear materials at fuels and material facilities. These national standards have been approved by the American Nuclear Society Committee N16 on Nuclear Criticality Safety and by the American National Standards Institute (ANSI). ANSI/ANS-8 nuclear criticality safety standards provide guidance and criteria on good practices for nuclear criticality safety generally acceptable to NRC for the prevention and mitigation of nuclear criticality accidents.

The licensing criteria for the disposal of spent fuel and HLW in the proposed geologic repository at Yucca Mountain are set forth in 10 CFR Part 63. There are no formal regulatory guidance documents or industry standards specific to criticality in a permanent HLW repository.

Criticality is one of the processes or events considered in the operational or pre-closure phase and the post-closure phase for the Yucca Mountain repository (in 10 CFR Part 63). During operation, DOE is required to have methods in place to prevent and control a criticality event. An analysis of the effectiveness of the safety systems to limit potential exposures is required at 10 CFR 63.112. The potential for criticality during the post closure period is evaluated as part of the process for developing the total system

---

<sup>91</sup>International Atomic Energy Agency, Guidelines Regarding the Form and Structure of National Reports: *Joint Convention on the Safety of Spent Fuel Management and on the Safety of Radioactive Waste Management* (INFCIRC/604), Vienna, Austria, December 13, 2002.

performance assessment (TSPA), consistent with the requirements of 10 CFR 63.112 applicable to all features, events, and processes applicable to long term performance. If the probability of a criticality event is sufficiently likely (i.e., is greater than the regulatory probability limit of one chance in 10,000 in 10,000 years), DOE must consider the consequences when the event occurs.

Evaluation of the probability and consequences (if necessary) of in-package criticality involves considering whether conditions inside the waste package (WP) could influence the occurrence of criticality and how in-package criticality could affect WP and engineered barrier subsystem performance. External criticality scenarios were also considered in the development of the TSPA.

Criteria for criticality for the independent storage of spent fuel, HLW, and GTCC waste are defined in NRC regulations in 10 CFR Part 72, *Licensing Requirements for the Independent Storage of Spent Nuclear Fuel, High-level Radioactive Waste, and Reactor-related Greater Than Class C Waste*, Subpart F, *Criteria for Nuclear Criticality Safety*. This addresses design for criticality safety, methods of criticality control, and criticality monitoring.

#### **F.7.1.2 Removal of Residual Heat**

Storage systems (for both HLW and spent fuel) are required to have reliable passive heat removal capability. NRC regulations and DOE orders require the decay heat removal system storage systems be capable of reliable operation so the temperatures of materials used for systems, structures, and components (SSCs) important to safety, e.g., fuel assembly cladding material, and solidified high-level waste packages, remain within the allowable limits under normal, off-normal, and accident conditions. Additionally, wet and dry fuel assembly transfer systems must also have adequate decay heat removal under normal, off-normal, and accident conditions.

Decay heat removal systems may be passive (natural convection and thermal radiation) for dry storage or may include active cooling systems (motors, pumps, heat exchangers, valve actuators, and switchgear) for wet or dry storage. The design must function within the original design basis thermal limits under normal, off-normal, and accident conditions. Technical specifications for heat removal capability for a storage system are proposed by the applicant or may result from the review and evaluation of submittals relating to those areas.

#### **F.7.2 Waste Minimization**

Waste minimization programs in the United States are mandated by law, regulations, and the President's Executive Order.<sup>92</sup> The Pollution Prevention Act of 1990, 42 U.S.C. § 13101 and 13102, focused industry, government, and public attention on reducing the amount of pollution through cost-effective changes in production, operation, and raw materials use.<sup>93</sup> Opportunities for source reduction are often not realized because existing regulations and the industrial resources required for compliance focus mainly on treatment and disposal. Source reduction, however, is fundamentally different and more desirable than waste management or pollution control.

---

<sup>92</sup> See <http://www.nepa.gov/nepa/regs/eos/eo13148.html>

<sup>93</sup> See <http://www.epa.gov/lawsregs/ppa.html>

EPA's Waste Minimization Program seeks to reduce or eliminate waste in manufacturing by promoting the concept of sustainability.<sup>94</sup> EPA works with industry, government agencies, and communities to voluntarily find ways to help them reduce the amount of waste they generate, particularly if the wastes contain one or more waste minimization priority chemicals.

Federal agencies, such as DOE, are subject to Executive orders mandating waste minimization and pollution prevention programs, particularly Executive Order 12780, *Federal Agency Recycling and the Council on Federal Recycling and Procurement Policy*, and Executive Order 12856, *Federal Compliance with Right-to-Know Laws and Pollution Prevention Requirements*. DOE has programs within the Office of Health, Safety and Security designed to reduce environmental releases and reduce the amount of waste eventually requiring treatment, storage, and disposal at DOE sites. Such activities include site-wide coordination, planning, reporting, employee awareness, assessments, incentives, cost-savings initiatives, recycling, and affirmative procurement programs.<sup>95</sup>

NRC has regulations (10 CFR 20.1406) requiring applicants for licenses to "...describe in the application how facility design and procedures for operation will minimize, to the extent practicable, contamination of the facility and the environment, facilitate eventual decommissioning, and minimize, to the extent practicable, the generation of radioactive waste." Even before the promulgation of this regulation, NRC had established waste minimization as a policy (46 FR 51100, October 16, 1981). The cost of disposal of radioactive waste in the United States provides a strong incentive to waste generators to practice waste minimization. On a case-specific basis, NRC licensees are encouraged to manage their activities to limit the amount of radioactive waste they produce; those activities would be reviewed in any license application to ensure waste minimization and volume reduction practices are included. NRC has requested organizations to provide information on volume reduction techniques and to share the information with licensees. Techniques include avoiding the spread of radioactive contamination, surveying items to ensure they are radioactive before placing them in a radioactive waste container, using care to avoid mixing contaminated waste with other trash, using radioactive materials whose radioactivity diminishes quickly, and limiting radioactive material usage to the minimum necessary to establish the objective.

Licensees as a practical matter take steps to reduce the volume of radioactive waste after it has been produced due to the cost of disposal at licensed commercial burial sites. Common means are compaction and incineration. About 59 NRC licensees are authorized to incinerate certain LLW, although most incineration is performed by a small number of commercial incinerators.

The most recent NRC initiative on waste minimization was the release of Regulatory Guide 4.21, *Minimization of Contamination and Radioactive Waste Generation: Life-Cycle Planning*, June 2008.<sup>96</sup> This guidance reaffirms the requirements of 10 CFR 20.1406 and provides examples of measures which can be combined to support a contaminant management philosophy. This philosophy includes prevention of

---

<sup>94</sup> See <http://www.epa.gov/epaoswer/hazwaste/minimize/about.htm>

<sup>95</sup> DOE's Pollution Prevention home page is at <http://www.hss.energy.gov/pp>

<sup>96</sup> Regulatory Guide 4.21 is available at <http://www.nrc.gov>

unintended release, early detection of potential releases, and aggressive cleanup when releases happen.

### **F.7.3 Interdependencies Among the Different Steps in Spent Fuel and Radioactive Waste Management Processes**

Successful management of spent fuel and radioactive waste requires careful integration among power or research reactors, waste generators, storage facilities, treatment facilities, disposal sites, the geologic repository project, and their transportation interfaces. Integration is achieved through interface management, such as specified waste acceptance criteria, so generators and disposers have a common understanding of the waste. Acceptance requirements define the interfaces. The United States recognizes the importance of this integration and manages the interfaces between various steps, e.g. storage, transportation, and disposal.

The U.S. Government uses a system composed of inspections, enforcement, quality assurance, testing and record keeping, thereby ensuring interdependencies among these steps remain relatively seamless. Manifests are used for transportation of radioactive material, including radioactive waste and spent fuel. Portal monitors and other monitors located at specific check points are used to confirm the characteristics of radioactive materials as they are transferred within a site, as well as in shipments between facilities. Disposal facility operators use the monitoring results to review and verify the validity of assumptions made and to update the assessments as specified in Article 15 for the period after closure. There is no single system to trace all radioactive waste, however, the United States has regulations governing cradle-to-grave management of radioactive waste, and waste managers are responsible for the safety of their inventories under the terms of their licenses or safety bases.

### **F.7.4 National Laws/Regulations Providing Protection and Taking Into Account International Criteria and Standards**

The United States has an extensive and comprehensive set of laws and regulations for radiation protection, meeting the intent of Article 4 and Article 11 of the Joint Convention. EPA (Section E) is responsible for developing national standards on radiation protection. The U.S. Government works with international organizations, e.g., the International Atomic Energy Agency (IAEA), and the International Commission on Radiation Protection (ICRP), to ensure U.S. standards are in general harmony with recommendations from these organizations. NRC, DOE and EPA are involved in the process of revising and drafting IAEA Safety Standards relating to nuclear, radiation, waste and transport safety. Because transportation is excluded from the definitions of radioactive waste and spent fuel management (see Article 2, items (i) and (n)), the activities supporting the revision of Safety Standard TS-R-1 are not discussed in this report. However, the U.S. Government has a very active role in the radiation safety standards committee, the waste safety standards committee, the nuclear safety standards committee, and the Commission on Safety Standards. There are standing members of these committees from the United States in diverse agencies. These committees meet biannually to review and approve safety standards for publication by the IAEA.

A few specific safety standards, to which the United States has devoted significant effort, are the:

- Fundamental Safety Principles, Safety Standards Series No. SF-1
- International Basic Safety Standards for Protection against Ionizing Radiation (revision of Safety Series No. 115); draft.
- Classification of Radioactive Waste Governmental and Regulatory Framework for Nuclear Safety (Revision of 111-G-1.1), draft
- Radiation, Radioactive Waste and Transport Safety (Revision of GS-R-1), draft.

The US believes these standards are a valuable source of guidance that a country can use to establish or enhance its national programs. These standards, however, do not prescribe the only approach to establishing strong national programs and are not binding on any country, except to the extent an individual country, acting in accordance with its national processes, incorporates all or part of them into its national law or regulations.

Several agencies are now using or allowing the use of the updated dose coefficients found in ICRP Publications 68 and 72. However, the United States has not adopted the annual dose limits in ICRP 60. New recommendations have been issued by the ICRP and most U.S. agencies are studying those changes before considering any revisions to current public and worker dose limits. Any change from effective dose equivalent to effective dose as the basis for human dosimetry has not yet occurred on a broad scale, although new regulations may incorporate the newer dose methods. For example, EPA has proposed to apply the ICRP 60 method at Yucca Mountain, rather than the ICRP 26 method.

#### **F.7.5 Biological, Chemical and Other Hazards**

The United States has major environmental laws taking into account biological, chemical, and other hazards. Operators of facilities must abide by these laws to protect workers, the public and the environment. Laws are enforced through the implementation of EPA regulations. EPA in turn delegates some regulatory authority to states meeting the minimum Federal requirements. One such law is the Resource Conservation and Recovery Act (RCRA), which grants EPA the authority to control hazardous waste from the “cradle-to-grave.” This includes the generation, transportation, treatment, storage, and disposal of hazardous waste. RCRA also sets forth a framework for the management of non-hazardous solid wastes. The 1986 amendments to RCRA enabled EPA to address environmental problems resulting from underground tanks storing petroleum and other hazardous substances. RCRA focuses only on active and future facilities and does not address abandoned or historical sites covered by the Comprehensive Environmental Response, Compensation, and Liability Act (CERCLA or Superfund), 42 U.S.C. 9601. The 1984 Federal Hazardous and Solid Waste Amendments to RCRA required phasing out land disposal of untreated hazardous waste. Some of the other mandates of this strict law include increased enforcement authority for EPA, more stringent hazardous waste management standards, and a comprehensive underground storage tank program.

Impacts from chemical hazards are assessed as part of the environmental assessment process. These assessments are required prior to constructing spent fuel and radioactive waste management facilities. The Environmental Impact Statement for



Yucca Mountain,<sup>97</sup> for example, examined the consequences for chemically toxic materials, which were found to be lower than identified Maximum Contaminant Level Goals for drinking water. Heavy metal elements were of particular interest, including chromium, molybdenum, nickel, and vanadium contained in the metals proposed to package the waste and support the packages. DOE concluded there are no impacts to water quality or human health from toxic materials exceeding EPA standards for the proposed repository.

#### **F.7.6 Avoidance of Undue Burden/Impacts on Future Generations**

U.S. policy to dispose of spent fuel and radioactive waste is aimed at not placing undue burdens on future generations. Real progress made toward timely decommissioning of inactive nuclear facilities and permanent disposal of spent fuel and radioactive waste is a strong component of a strategy to minimize the impacts to future generations from these materials. Performance requirements on disposal sites mandate the level of isolation to ensure there are no undue burdens on future generations. The Waste Isolation Pilot Plant (WIPP) geologic repository for TRU waste and the proposed Yucca Mountain repository demonstrate the United States is addressing the burden/impacts on future generations as national policy.

U.S. experts maintain contacts with international organizations engaged on such issues. Members of the NCRP work directly with their counterparts in the international community. A panel of the National Academy of Public Administration has studied the issues involved and issued a report<sup>98</sup> addressing these issues.

Among the numerous findings from this panel, it was recognized that every generation is a trustee for those that follow and noted that there is an obligation to protect future generations provided that the interests of the present generation and its immediate offspring are not jeopardized. The panel also noted that near-term concrete hazards have priority over long-term hypothetical hazards, but preference for present and near future is reduced when dealing with questions of irreversible harm or a plausible threat of catastrophic effects.

The NAS Nuclear and Radiation Studies Board (which combined the Board of Radioactive Waste Management and the Board on Radiation Effects Research) considers the public policy, sociological, and ethical aspects of radioactive waste management, for example, long-term societal commitments, societal acceptability of waste management practices, and institutional capabilities to effectively and efficiently manage radioactive wastes.

#### **F.8 Existing Facilities (Articles 5 and 12)**

Article 5 and Article 12 of the Joint Convention specify each Contracting Party must take steps to review safety of any spent fuel and radioactive waste management facility

---

<sup>97</sup> DOE, *Final Environmental Impact Statement for a Geologic Repository for the Disposal of Spent Nuclear Fuel and High-Level Radioactive Waste at Yucca Mountain, Nye County, Nevada*, DOE/EIS-0250, Washington DC, February 2002. DOE, *Final Supplemental Environmental Impact Statement for the Disposal of Spent Nuclear Fuel and High-Level Radioactive Waste at Yucca Mountain, Nye County, Nevada*, DOE/EIS-0250F-S1, June 2008.

<sup>98</sup> [www.hss.energy.gov/nuclearsafety/nsea/oepa/reports/napa/pdf](http://www.hss.energy.gov/nuclearsafety/nsea/oepa/reports/napa/pdf).

existing at the time the Convention enters into force and to ensure, if necessary, all reasonably practicable upgrades are made.

The United States is fully compliant with the provisions of Article 5 and Article 12 of the Joint Convention. The United States conducts safety reviews of both commercial and governmental spent fuel and radioactive waste management facilities under its existing regulations. No additional reviews of existing facilities are required to comply with the Joint Convention because existing facilities are already subject to periodic safety reviews. The frequency and type of assessments and inspections depend on the type of facility and results of previous safety reviews.

## **F.9 Siting Proposed Facilities (Articles 6 and 13)**

The United States is fully compliant with Article 6 and Article 13 of the Joint Convention. The United States has legal and regulatory structures described in Section E to site proposed new facilities. The process provides for evaluation of all relevant site related factors, safety impacts to workers, the public, and the environment, and socio-economic impacts.

### **F.9.1 Environmental Assessment (NEPA Process)**

The National Environmental Policy Act of 1969 (NEPA) is the basic National charter for protection of the environment. It establishes policy, sets goals, and provides means for carrying out the policy. Federal agencies have implementing regulations, e.g., Council for Environmental Quality (40 CFR 1500), DOE (10 CFR Part 1021), NRC (10 CFR Part 51), and EPA (40 CFR Part 6). NEPA requires Federal agencies to integrate environmental values into their decision-making processes by considering the environmental impacts of their proposed actions and reasonable alternatives to those actions. NEPA requirements are invoked when airports, buildings, military complexes, highways, parkland purchases, and other Federal activities, such as spent fuel and radioactive management facilities, are proposed. This NEPA process is employed for any significant changes in the facility during the operating period, e.g., additional waste types are disposed or new facilities are added.

The public has an important role in the NEPA process. Public input is obtained on what issues should be addressed in an Environmental Impact Statement (EIS) and on an agency's draft NEPA documents. The public can participate in the process by attending NEPA-related hearings or public meetings and by submitting comments directly to the lead agency. The lead agency must consider all comments received on draft NEPA documents during the comment period.

The EIS is prepared consistent with 40 CFR 1500-1508 requirements, and addresses impacts of a nuclear waste repository in 12 resource areas including: land use, air quality, hydrology, cultural resources, biological resources, human health and safety, socioeconomics, noise, consumption of resources, waste management, aesthetics, and environmental justice. Applicable occupational and mine safety regulations must also be satisfied.

## **F.9.2 Site Selection**

NRC regulations prescribe site characterization activities and pre-license application reviews by NRC, as well as the application requirements for licensing and construction authorization. The regulations also provide for participation in the pre-licensing (site) review and licensing review by states, affected tribes, and other interested stakeholders. Information is publicly available through the formal licensing docket maintained in public reading rooms by NRC.

Site selection for a new spent fuel or waste management facility is embodied in the environmental assessment process (implementation of NEPA), evaluating relevant site safety factors, safety of workers and the public, impacts to the environment, and socio-economic impacts. Licensees select a site based on consideration of many factors. These factors include the geography, demography, meteorology, hydrology, seismology, and the geology characteristics of the site and the surrounding area. Nearby industrial, transportation, sensitive areas, park lands, historical sites, and military facilities are also a consideration in the selection process. The licensee uses site characteristics to determine the influence on the facility design. The licensee will then evaluate the site characteristics from a safety viewpoint.

From the information supplied in response to the regulations, NRC can determine if (1) the applicant has properly identified the external natural and man-induced phenomena for inclusion in the design basis and whether the design basis levels are adequate; (2) the applicant has adequately characterized local land and water use and population so important individuals and populations likely to be affected can be identified; and (3) the applicant has adequately characterized the processes, which could move any released contamination from the facility to the affected individuals and populations.

NRC's regulations at 10 CFR 72.102 and 10 CFR 72.103 contain specific requirements for geological and seismological characteristics in the approval of sites for independent storage of spent nuclear fuel, high-level radioactive waste, and reactor-related Greater-than-Class C waste. Depending on their geographic location, certain sites may be analyzed by using the criteria and level of investigations required by Appendix A of 10 CFR Part 100. NRC then determines the acceptability of the site-derived design bases and design basis events incorporated into the proposed design analysis. NRC also evaluates whether the applicant's determination of the affected individuals and populations and the dispersion parameters result in compliance with NRC radiation protection requirements.

## **F.9.3 Public and Stakeholder Involvement**

The United States recognizes the many benefits derived from public participation in its program activities, including spent fuel and radioactive waste management. Public participation is open, ongoing, two-way communication—both formal and informal—between government officials and stakeholders. Public participation provides a means for the government to gather the most diverse collection of opinions, perspectives, and values from the broadest spectrum of the public, enabling the government to make better, more informed decisions. Public participation benefits stakeholders by creating an opportunity to provide input and influence decisions.

NRC views nuclear regulation as the public's business, and as such, identifies openness in its regulatory process as an explicit goal of the Agency. NRC recognizes it must inform the public about the regulatory process, and offer a reasonable opportunity for meaningful participation. NRC long ago established mechanisms and procedures to afford the public access to major regulatory decisions. NRC has recently examined ways to enhance public involvement and foster confidence in NRC's actions as an effective and independent regulator. NRC is seeking to expand opportunities for public access to clear and understandable process and risk information. NRC has developed fact sheets and brochures as part of its public outreach strategy. These documents provide information to members of the public about different topics, including decommissioning, spent fuel, and radioactive waste.<sup>99</sup> NRC sought to improve its efforts to inform and involve the public in NRC's decision-making process on rulemaking when developing new, site-specific regulations for the proposed geologic repository at Yucca Mountain. Major changes were made to the way technical staff members prepare for speaking to general audiences. The format used for public meetings was modified to encourage dialogue with participants. Handout and presentation materials explaining NRC's role and technical topics of concern, in plain language, were developed and are regularly updated. NRC successfully applied these and other institutional changes as it completed final regulations for Yucca Mountain, when introducing a draft license review plan for public comment, and when responding to public requests for information on NRC's licensing and hearing process.

Congress enacted the WIPP Land Withdrawal Act in October 1992, giving EPA significant new responsibilities for certifying DOE's determination of compliance at WIPP. EPA, in implementing its responsibilities, committed to conducting an open public process including interaction with all interested parties. A successful communications and consultation program facilitates the regulatory oversight process and promotes sound public policy decisions. EPA conducted a public consultation and communication "needs assessment" as a first step in meeting its commitment to an open public process. This assessment was designed to obtain input from citizen and environmental groups and the public on their key concerns about EPA's role and responsibilities at the WIPP, and the best methods for communicating with them. EPA provided opportunities throughout the WIPP certification process, for public involvement beyond those required in typical U.S. regulatory programs. This increased the public's understanding of EPA's role and responsibilities for the WIPP project, enabled the public to make informed decisions about the project by increasing their knowledge about radiation and its risks, and enhanced the overall decision-making process.<sup>100</sup>

Many DOE sites have formed formal panels made up of interested citizens to advise the government on planned ongoing activities under the Federal Advisory Committee Act. Site-Specific Advisory Boards (SSABs) provide consensus advice and recommendations to DOE spent fuel and waste management activities at most locations where spent fuel and radioactive waste is stored. The boards, which are voluntary and not required by law, provide advice and offer recommendations on DOE activities. When established (as one is at Hanford for example), the SSABs are subject to the Federal Advisory Committee Act of 1972. In addition, there are other panels formed to advise DOE at the

---

<sup>99</sup> See <http://www.nrc.gov/reading-rm/doc-collections/fact-sheets/>

<sup>100</sup> Additional information on the WIPP outreach program was provided in the second U.S. National Report in Annex

F-8. See <http://www.epa.gov/radiation/WIPP>

program and secretarial office level, e.g. the Environmental Management Advisory Board and the Secretary of Energy Advisory Board. These groups review broader agency actions and policies, providing advice and guidance to senior governmental officials.

DOE has multilateral agreements with national waste management organizations and international organizations, e.g., IAEA and Nuclear Energy Agency (NEA). EPA and NRC conduct public hearings and public meetings, accept written and electronic comments on proposed actions, participate in stakeholder meetings, and provide internet sites.<sup>101</sup> NRC's internet website provides a full description of the agency's public information process and meeting calendar.

EPA's Office of International Affairs and NRC's Office of International Programs participate in international organizations (NEA, IAEA, ICRP, etc.) and bilateral activities with United States neighbors, such as Canada and Mexico.

### **F.10 Design and Construction of Facilities (Articles 7 and 14)**

Articles 7 and 14 of the Joint Convention require parties to take appropriate steps to ensure design and construction of spent fuel and radioactive waste management facilities have measures to limit possible radiological impacts and discharges or uncontrolled releases, provisions are taken into account at the design stage for decommissioning, and technologies are supported by experience, testing and analysis. The United States is fully compliant with Articles 7 and 14 of the Joint Convention.

DOE has a series of regulations and orders establishing requirements for protection of the public and the environment. Most DOE work is accomplished through contracts with the private sector, so competitive market forces have been effective in driving the contractors to implement efficient and safe techniques to continue to win DOE contracts. NRC also evaluates the licensee's or responsible party's proposed decommissioning plan, (for materials facilities) or license termination plan (for reactor facilities) including the licensee's justification for using a particular remediation methodology, to determine if it is appropriate for the specific decommissioning project.

General design criteria in NRC regulations set the minimum requirements for the applicant's principal design criteria. These in turn establish the necessary design, fabrication, construction, testing, and performance requirements for structures, systems and components important to safety.

Quality assurance programs, described in Section F.3, are an integral part of NRC and DOE safety programs. Quality assurance programs are applied to design, purchase, fabrication, handling, shipping, storing, cleaning, assembly, inspection, testing, operation, maintenance, and repair, and modification of structures, systems and components important to safety.

DOE has provisions in 10 CFR Part 830 requiring design of DOE nuclear facilities to include nuclear safety, explosives safety, and fire protection. DOE Order 420.1A, *Facility Safety* also requires all facilities during operation must be designed for protection

---

<sup>101</sup> See <http://www.epa.gov/radiation/index.html> and <http://www.nrc.gov>

from natural phenomena, such as earthquakes and tornadoes and designs facilitate safe deactivation, decommissioning, and decontamination at end of their operating life.

### **F.11 Assessment of Safety of Facilities (Articles 8 and 15)**

The Joint Convention requires a systematic safety assessment and an environmental assessment appropriate to the hazards present at the facility be prepared to cover the entire life cycle. Updated and detailed assessments are required before operations. Safety assessment is a stand alone process and in addition is addressed as part of the NEPA process. NRC employs a risk-informed and performance based approach to decision-making where risk insights are considered along with other factors such as engineering judgment, safety limits, redundancy, and diversity. Risk insights are gathered by asking three questions: “What can go wrong?” “How likely is it?” and “What are the consequences?” A risk assessment is a systematic method for addressing these three questions to understand likely outcomes, sensitivities, areas of importance, system interactions, and areas of uncertainty. This is applied agency-wide in the decision making process.

#### **Example of Risk-Informed, Performance-Based Decision Making**

A risk-informed approach to decision-making was used in developing the revised seismological and geological requirements in the Final Rule to 10 CFR Part 72 for dry cask Independent Spent Fuel Storage Installations (ISFSIs) and DOE Monitored Retrievable Storage (MRS) facilities, which became effective on October 16, 2003. The Final Rule requires applicants who are proposing a dry cask ISFSI or MRS facility located west of the Rocky Mountain Front and other areas of known seismicity, to use the probabilistic seismic hazard analysis methods (PSHA) in evaluating the earthquake hazards, instead of deterministic methods in 10 CFR 100 Appendix A. The rule removes the requirement that a design earthquake (DE) of a dry cask ISFSI or MRS facility be equivalent to the Safe Shutdown Earthquake for a nuclear power plant, and allows the DE to be determined based on the lower risk at a dry cask ISFSI or MRS facility compared to a nuclear power plant. The Final Rule makes the 10 CFR Part 72 earthquake regulations risk-informed, and performance-based.

### **F.12 Operation of Facilities (Articles 9 and 16)**

The United States uses results of inspection, monitoring, and testing to verify and review safety assessment assumptions (Article 16(iii)). NRC regulations require licensees to update safety assessments whenever significant new information becomes available possibly reducing a margin of safety or requiring a change to license conditions.

NRC regulations require operations under a safety envelope. NRC has regulations in 10 CFR Part 61 and internally developed licensing and inspection programs governing the authorization to operate low-level radioactive waste disposal facilities. NRC regulations for issuing site-specific licenses for the operation of Independent Spent Fuel Storage Facilities are in 10 CFR Part 72. The performance-based ISFSI regulations in 10 CFR Part 72 incorporate a graded approach and are in addition to the requirements of 10 CFR Part 50 for the domestic licensing of a nuclear power plant. Applicants for such licenses must provide sufficient information about their organization to demonstrate a capability to operate their facility safely. NRC (or Agreement State) issues licenses to each of the companies managing or disposing of radioactive waste, either exclusively or as part of other activities such as energy production to assure “continuity of safe

operation.” The license defines the terms and conditions ensuring safety from the handling, processing, transporting, transferring and/or disposing of materials.

Operations safety data are reported to or identified by NRC in event reports, inspection reports, component failure reports, industry reports, safeguard and security events, reports of defects and noncompliance (10 CFR Part 21), and reports of operation experience at foreign facilities. NRC screens operations safety data for safety significance, trends and generic implications, and the need for further regulatory action. NRC also develops, coordinates, and issues generic communications to alert industry to safety concerns and recommends the need for special inspections or event investigations.<sup>102</sup>

Examples of investigated operational issues include loose/leaking pressure switches, loose lid bolts, corrosion of outer metallic lid seals, vent and drain port cap installation problems, crane and rigging issues, pad issues, and unapproved fuel loading issues. Specific examples in the area of radioactive waste management include violation of possession limits, improper disposal of radioactive material generated from cleanup operations, and the failure to prevent radiation levels from exceeding the U.S. Department of Transportation and NRC limits on the external surface of a radioactive waste shipment package.

NRC’s safety oversight program is designed to limit exposures to acceptable limits and maintain them to ALARA, protect the environment, and safeguard radioactive material from terrorist threats. The oversight program includes inspections and assessments of licensee and vendor activities with a focus on minimizing risk to public health and safety.

NRC periodically inspects the design, fabrication, and use of dry cask storage systems by sending inspectors to licensee and cask vendor and fabricator facilities. The inspectors examine whether licensees and vendors are performing activities in accordance with radiation safety requirements, licensing and certificate of compliance requirements, and quality assurance program commitments. Inspectors follow guidance in NRC’s Inspection Manual,<sup>103</sup> containing objectives and procedures to use for each type of inspection (Annex F-1).

NRC issues reports to document inspection findings. These inspection reports may contain enforcement actions and follow-up inspection items. NRC makes most inspection reports electronically available for public review. Spent fuel storage inspection reports for example can be located by searching for documents with a cask designer’s name or docket number, or an ISFSI name or docket number.

Licensees are required to comply with NRC regulations, the license, and associated technical specifications. This includes conducting internal audits or assessment of its safety programs. NRC also conducts routine safety inspections of ISFSIs and of vendors and fabricators of dry cask storage systems. Announced or unannounced NRC inspections are conducted during the pre-operational testing, and periodically between one and three years to determine if the licensee is in full compliance. Licenses and the technical specifications included in Certificates of Compliance for cask designs contain additional inspection/review requirements.

---

<sup>102</sup> See <http://www.nrc.gov/reading-rm/doc-collections/gen-comm/>

<sup>103</sup> See <http://www.nrc.gov/reading-rm/doc-collections/insp-manual/>

### F.12.1 NRC Inspection of Commercial Licensed Facilities and Activities

NRC inspects licensed commercial nuclear power plants, research reactors, fuel cycle facilities, and radioactive materials activities and operations. Inspectors follow guidance in the NRC Inspection Manual, containing objectives and procedures for each type of inspection. If an inspection identifies that a licensee is not in compliance with regulatory and/or license requirements, NRC informs the licensee of the problems found and provides the licensee an opportunity to address the problems. NRC conducts follow-up inspections to ensure problems are corrected.

In addition to region-based inspections, NRC resident inspectors carry out the inspection program on a day-to-day basis at each major fuel cycle facility, e.g., Paducah Gaseous Diffusion Plant. Nuclear criticality safety and materials control and accounting inspections of fuel cycle facilities are conducted by both NRC Headquarters and Regional personnel; Regional inspectors focus primarily on operational issues, as opposed to analytical issues.

NRC conducts approximately 1,400 inspections of its nuclear material licensees per year. These inspections review areas such as training, radiation protection programs, patient dose records, and security. Specific inspection procedures relating to radioactive waste or spent fuel management are listed in Annex F-1. Certain inspection activities and responsibilities for radioactive waste and/or spent fuel management overlap with operational considerations. Such cases are addressed in operational inspection manual chapters.<sup>104</sup>

### F.12.2 NRC Enforcement and Civil Penalties

If licensees violate regulatory or license requirements, NRC initiates its enforcement process, based on the investigation of results from inspection, testing or other violation identification mechanisms, including allegations. Apparent violations are assessed in accordance with NRC's Enforcement Policy. The policy was published as NUREG-1600, *General Statement of Policy and Procedure for NRC Enforcement Actions*, to foster its widespread dissemination to NRC licensees and members of the public.<sup>105</sup>

The Office of Enforcement exercises oversight of NRC enforcement programs, provides programmatic and implementation direction to regional and headquarters offices conducting or involved in enforcement activities, and ensures regional enforcement programs are adequately carried out. NRC uses three primary enforcement actions:

1. *Notices of Violation*: A Notice of Violation (NOV) identifies a requirement, how it was violated, and formalizes a violation pursuant to 10 CFR 2.201. NOVs normally require the licensee to provide a written response.

---

<sup>104</sup> A full list is presented at <http://www.nrc.gov/reading-rm/doc-collections/insp-manual/manual-chapter/index.html#page-content>

<sup>105</sup> NUREG report available at <http://www.nrc.gov/about-nrc/regulatory/enforcement/enforce-pol.html>



2. *Civil Penalties:* A civil penalty is a monetary fine issued under authority of Section 234 of the AEA or Section 206 of the Energy Reorganization Act (ERA), of 1974 as amended. Section 234 of the AEA provides for penalties of up to \$100,000 per violation per day. This amount has been adjusted by the Debt Collection Improvement Act of 1996 and is now \$130,000.
3. *Orders:* An order may modify, suspend, or revoke a license or require or confirm specific actions by a licensee or a person.<sup>106</sup>

NRC order issuing authority under Section 161 of the AEA extends to any area of licensed activity affecting the public health and safety. NOVs and civil penalties are issued based on the significance of the violations. Orders may be issued for violations, or in the absence of a violation, to address a public health or safety issue.

NRC assesses significance of identified violations by considering actual safety consequences, potential safety consequences, potential for impacting NRC's ability to perform its regulatory function, and any willful aspects of the violation.

NRC enforcement response to violations reflects the seriousness of the violation and the circumstances involved. Minor violations are not subject to enforcement action and are not normally described in inspection reports. Minor violations, like all violations, must be corrected. This approach for violations having low risk significance is consistent with the agency's performance goals. More significant violations are candidates for escalated enforcement. A graphical representation of NRC graded approach for dispositioning violations is included on NRC's website.<sup>107</sup>

**CALENDAR YEAR 2006 NRC ENFORCEMENT SUMMARY HIGHLIGHTS**

- The Enforcement Policy was revised one time.
- NRC issued 87 escalated enforcement actions, including:
  - 57 escalated Notices of Violation without civil penalties
  - 15 proposed civil penalties totaling \$ 332,350
  - 15 orders modifying, suspending, revoking a license, or prohibiting involvement in NRC-licensed activities.
  - Included in this number are eight orders that were issued as part of the agency's use of Alternative Dispute Resolution in enforcement cases
  - No orders imposing civil penalties issued
- The performance and administrative metrics for completing cases were met for 100 percent of enforcement actions taken against NRC licensees.

A predecisional enforcement conference may be conducted with a licensee. The purpose of the conference is to obtain information to assist NRC in determining the appropriate enforcement action. Conferences are normally open to public observation. If NRC concludes a conference is not necessary, it may provide a licensee with an opportunity to respond to the apparent violations before it makes an enforcement decision. Conferences open to public observation are included in the listing of public meetings on NRC's web site.

NRC may issue orders to modify, suspend, or revoke a license; to cease and desist from a given practice or activity; or take such other action as may be proper. Orders may be issued in lieu of, or in addition to civil penalties. NRC may also issue an order to impose a civil penalty where a licensee refuses to pay a civil penalty. It also may issue an order

<sup>106</sup>The term *order* within this context is distinguished from a DOE order, which is a directive and/or policy for radiation protection of the public and environment that applies to DOE sites and contractors.

<sup>107</sup> See <http://www.nrc.gov/about-nrc/regulatory/enforcement/enforce-pro.html>

to an unlicensed person (including vendors) where the agency has identified deliberate misconduct.<sup>108</sup> NRC addresses allegations raised by subcontractors or anyone against the licensee or anyone involved in the operation of the facility.<sup>109</sup> Similarly, DOE has a program in place for workers raising health and safety allegations.

A licensee or individual may request a hearing upon receiving an order. Orders are normally effective after a licensee or individual has had an opportunity to request a hearing (30 days). Orders can be made immediately effective without prior opportunity for a hearing, however, when it is determined the public health, safety, or interest so requires. A licensee or individual may appeal the administrative hearing decision to the court of appeals after the hearing.

Civil penalties are normally assessed for severity violations, as well as deliberate violations of the reporting requirements of Section 206 of the Energy Reorganization Act. Civil penalties are considered for lesser severity violations. Civil penalties (and the use of severity levels) will be considered for willful issues. Additional details on severity levels and recent enforcement actions for materials facilities are available from the NRC website.<sup>110</sup>

NRC imposes different levels of civil penalties based on several factors, such as severity level of the violation, history of past violations, and promptness and comprehensiveness of corrective actions. The assessment process for each violation or problem (absent the exercise of discretion) results in one of the following three outcomes: no civil penalty, a base civil penalty, or twice the base civil penalty. If a civil penalty is proposed, a written Notice of Violation and Proposed Imposition of Civil Penalty is issued and the licensee has 30 days to respond in writing. It can do so by either paying the penalty or contesting it. NRC considers the response, and if the penalty is contested, may either mitigate it or impose it by order. The licensee may then pay the civil penalty or request a hearing.

NRC issues a press release for each proposed civil penalty or order. All orders are made available to the public. Significant enforcement actions (including actions to individuals) are included in the Enforcement Document Collection in the Electronic Reading Room of NRC's web site.

### **F.12.3 Operation of DOE Facilities**

DOE facilities fall under numerous regulations and orders mandating similar operational safety requirements as NRC. DOE's safety regulation, 10 CFR Part 830, requires a comprehensive nuclear safety program at all DOE nuclear facilities, including spent fuel management facilities. The regulation requires a safety basis be developed including a documented safety analysis and technical safety requirements placing appropriate limits on operations. A facility safety basis is a set of documented controls providing reasonable assurance DOE facilities are operated safely and protects workers, the public, and the environment. 10 CFR Part 830, Subpart B, *Safety Basis Requirements*, requires contractors operating DOE nuclear facilities to submit safety basis documents meeting its requirements. DOE contractors have to document the work to be performed,

---

<sup>108</sup> Deliberate misconduct (10 CFR 30.10) is voluntary intentional conduct (action or inaction) to violate a known requirement.

<sup>109</sup> For more information, refer to <http://www.nrc.gov/about-nrc/regulatory/allegations-resp.html>

<sup>110</sup> See <http://www.nrc.gov/reading-rm/doc-collections/enforcement/actions/materials/>

analyze the hazards, and implement controls to protect workers, the public, and the environment from nuclear or radiological hazards. DOE standards identified in Appendix A of the Rule further dictate the content of the safety documents. DOE then applies its own formal review and a performance-based formal enforcement program to ensure contractors adhere to their documented safety controls. Integrated Safety Management requirements, invoked through DOE acquisition regulations, produce a sound, enforceable system to ensure adequate protection from nuclear and radiological work hazards. Additional guidance on the implementation of 10 CFR Part 830 is found in DOE G 421.1-1, *Criticality Safety Good Practices Guide for DOE Nonreactor Nuclear Facilities*, DOE G 421.1-2, *Implementation Guide For Use in Developing Documented Safety Analyses To Meet Subpart B Of 10 CFR 830*, and DOE G 423.1-1, *Implementation Guide For Use In Developing Technical Safety Requirements*.

Detailed safety analysis reports are developed, including analysis of credible accident scenarios. Additional guidance on safety analysis is found in DOE G 421.1-2. The safety basis is reviewed and approved by DOE management and documented in a Safety Evaluation Report. Safety analysis reports are updated and approved as necessary and updated annually or certified as unchanged.

Safety issues may arise during operations. Part 830 mandates an “unreviewed safety question” process formally resolving these issues. Additional guidance on this process is found in DOE G 424.1-1, *Implementation Guide For Use In Addressing Unreviewed Safety Question Requirements*. These regulations, orders and guidance ensure safety assessments are appropriate and maintained up to date during facility operations per the Joint Convention.

Operational safety incidents at DOE facilities fall into three principal areas, not nuclear safety related, but are important to worker safety:

- **Suspect/Counterfeit Items.** Suspect/counterfeit items (S/CI) do not meet QA standards, but are knowingly represented as meeting those standards. Such parts may be introduced into safety or mission-sensitive systems. DOE has instituted a Suspect/Counterfeit/ Defective Items Program to identify and counter the prevalence of S/CI. The S/CI Program has emphasized training, quality assurance inspections and has increased the general awareness of every DOE employee. DOE has identified 99 S/CI in 2006 and 98 S/CI in 2007. In the past, a majority of the items were fasteners and this is still a problem, but lately the program has effectively identified hoisting and rigging shackles, circuit breakers and other significant parts. Many of the S/CI were identified during the Site’s Quality Assurance Receipt and Inspection process. Next steps in the process are to reduce the number of S/CI events by working with buyers and vendors. There have been no injuries or known accidents associated with these parts and most of them have been discovered and removed prior to being placed into service, but the potential exists for worker injury, particularly when such parts are in lifting devices and container sealing systems.
- **Electrical Safety.** After several years of electrical safety events in DOE facilities staying at the same level, 2007 saw the number of events decrease slightly. Even so, electrical safety events are an ongoing safety concern and DOE has taken steps to address electrical safety, such as: a DOE-wide Electrical Safety Campaign, development of a Special Operations Report 2006-1, *Electrical Safety* and revisions

to DOE's *Electrical Safety Manual*. Other programmatic initiatives to improve electrical safety include:

- Development of DOE technical qualifications for electrical safety oversight personnel, *Electrical Systems and Safety Oversight Functional Area Qualification Standard*.
  - Development of an electrical incident severity index tool for use by DOE's Occurrence Reporting and Processing System (ORPS), which is used to collect and compile information on safety and operations events at DOE facilities.
  - Improved electrical safety training for electrical and non-electrical workers.
- **Hoisting and Rigging Events.** Safety challenges remain at DOE facilities as hoisting and rigging incidents continue to occur in all types of DOE operations. The level of rigor applied to planning and controlling hoisting and rigging tasks to ensure they are performed safely was sometimes insufficient and subsequently responsible for many reported events. A review and analysis of ORPS Hoisting & Rigging Occurrences from 2005 through 2007 reveals a decrease in the number of hoisting and riggings events DOE Wide. In 2007 there were 44 ORPS occurrences related to hoisting and rigging. While this is still too high, it was a decrease from the previous two years of 55 and 61 related occurrences. This demonstrates an improvement in the level of rigor applied to planning and controlling hoisting and rigging tasks to ensure they are performed safely.

The status of DOE nuclear facility safety documentation is formally tracked in DOE's Safety Basis Information System.<sup>111</sup> The data cover 227 DOE nuclear facilities, excluding facilities with extremely low hazard potential and safety basis documentation requirements do not apply.

**Fiscal Year 2006 DOE  
Contractor Enforcement Summary**

- 6 Notices of Violation
- \$2.6 million in proposed civil penalties
- \$390,000 assessed
- \$2.2 million waived

**Fiscal Year 2007 DOE  
Contractor Enforcement Summary**

- 4 Notices of Violation
- \$480,000 in proposed civil penalties
- \$480,000 in assessed
- \$0 waived

DOE Office of Price-Anderson Enforcement issued six Notices of Violation (NOVs) during 2006 totaling \$2.6 million in civil penalties against contractors at its sites. Three of the NOVs were mitigated (proposed penalty reduced) for contractor self-reporting and prompt corrective action. Contractor-identified corrective actions will be monitored to ensure effectiveness. DOE also conducted two program reviews during 2007 to assist contractors in identifying, reporting, and correcting non-compliances to reduce the risk of enforcement action. During 2007, the Enforcement Program continued to address safety violations. Four NOVs were issued and resulted in approximately \$480,000 in civil penalties.

<sup>111</sup> See <http://www.hss.energy.gov/nuclearsafety/nsps/sbis/>

## G. SAFETY OF SPENT FUEL MANAGEMENT

Section F described aspects common to spent fuel and radioactive waste safety per Articles 4-9 of the Joint Convention. This section provides additional information relative to the same Articles pertaining solely to spent fuel. This section also addresses Article 10 of the Joint Convention.

### G.1 General Safety Requirements (Article 4)

The need for general safety requirements is found in the Atomic Energy Act (AEA) and the Nuclear Waste Policy Act (NWPA), as amended. The licensing requirements for the independent storage of spent fuel, HLW, and reactor related Greater-than-Class C LLW waste are contained in 10 CFR Part 72. The licensing requirements for disposal of HLW and spent fuel at a permanent geologic repository are contained in 10 CFR Part 60, and in Part 63 for disposal in a geological repository at Yucca Mountain, Nevada. Other applicable regulations include 10 CFR Part 71, *Packaging and Transportation of Radioactive Material*; Part 73, *Physical Protection of Plants and Materials*; Part 75, *Safeguards on Nuclear Material-Implementation of US/IAEA Agreement*. Table E-2 lists key NRC regulations.

Although both pool storage and dry storage are safe methods for spent fuel management, there are significant differences. Pool storage requires a greater and more consistent operational vigilance by utilities or other licensees and the satisfactory performance of many mechanical systems using pumps, piping and instrumentation.

NRC approves dry cask spent fuel storage systems by evaluating each design for resistance to normal and off-normal conditions of use and accident conditions such as floods, earthquakes, tornados, and temperature extremes. The maximum allowable heat generation from the fuel assemblies stored in each cask may be different for each design. The maximum heat generated by the fuel in the highest capacity thermal cask is approximately equal to 400 100-watt light bulbs. The temperature of the fuel in the casks continuously decreases over time. The first spent fuel dry storage cask was placed in service in July 1986. No releases of spent fuel storage cask contents or other significant safety problems from the dry cask storage systems in use today have been reported.

NRC authorizes storage of spent fuel at an ISFSI under two licensing options: site-specific licensing and general licensing. Under a site-specific license, an applicant submits a license application to NRC and NRC performs a technical review of all the safety aspects of the proposed ISFSI. NRC issues a license valid for 20 years if the application is approved. NRC regulations also include provisions for renewal of an ISFSI

- A. Introduction
  - B. Policies & Practices
    - Article 32, paragraph 1
  - C. Scope of Application
    - Article 3.
  - D. Inventories & Lists
    - Article 32, paragraph 2
  - E. Legislative & Regulatory Systems
    - Article 18. Implementing Measures
    - Article 19. Legislative & Regulatory Framework
    - Article 20. Regulatory Body
  - F. General Safety Provisions
    - Article 21. Responsibility of License Holder
    - Article 22. Human & Financial Resources
    - Article 23. Quality Assurance
    - Article 24. Operational Radiation Protection
    - Article 25. Emergency Preparedness
    - Article 26. Decommissioning
  - G. Safety of Spent Fuel Management**
    - Article 4. General Safety Requirements
    - Article 5. Existing Facilities
    - Article 6. Siting of Proposed Facilities
    - Article 7. Design & Construction of Facilities
    - Article 8. Facility Safety Assessment
    - Article 9. Facility Operation
    - Article 10. Spent Fuel Disposal
  - H. Safety of Radioactive Waste Management
    - Article 11. General Safety Requirements
    - Article 12. Existing Facilities & Past Practices
    - Article 13. Siting of Proposed Facilities
    - Article 14. Design & Construction of Facilities
    - Article 15. Facility Safety Assessment
    - Article 16. Facility Operation
    - Article 17. Institutional Measures After Closure
  - I. Transboundary Movement
    - Article 27.
  - J. Disused Sealed Sources
    - Article 28.
  - K. Planned Activities to Improve Safety
- Annexes

license. A spent fuel storage license contains technical requirements and operating conditions (fuel specifications, cask leak testing, surveillance, and other requirements) for the ISFSI and specifies what the licensee is authorized to store at the site. The initial licensing period of 20 years is the same for wet storage and dry storage. A licensee also has an option for renewal at the end of the licensing term.<sup>112</sup>

A general license issued under 10 CFR Part 72, authorizes a nuclear power plant licensee to store spent fuel in NRC-approved dry storage casks at a site licensed to operate a power reactor under 10 CFR Part 50. Licensees are required to perform evaluations of their site to demonstrate the site is adequate for storing spent fuel in the chosen dry storage cask design, but no application or Safety Analysis Report is required for a general license. The site evaluations must show the terms and conditions and technical specifications in the storage cask's Certificate of Compliance (CoC) can be met, including analyses of earthquake intensity and tornados. The licensee must also review its security program, emergency plan, quality assurance program, training program and radiation protection program, and make any necessary changes to incorporate the ISFSI at its reactor site.

NRC has approved 15 dry storage systems, which potential general licensees may consider and for which they may receive a CoC. These designs are listed in NRC regulations (10 CFR 72.214). An NRC-approved cask has been technically reviewed for its safety aspects and found adequate to store spent fuel since it has been shown to meet NRC's requirements in 10 CFR Part 72. NRC issues a CoC for a cask design to a cask vendor if the review of the vendor's design finds it technically adequate. The cask certificate expires 20 years from the date of issuance with a re-approval option.

A general license is valid for as long as the as the licensee has a valid 10 CFR Part 50 nuclear power plant license and it continues to meet the other requirements of the general license. A new nuclear power plant operational license is typically valid for forty years. Renewals are generally for 20 years.

### **G.1.1 Interdependencies between Different Steps in the Spent Fuel Management Process**

NRC regulates all spent fuel management aspects from interim storage and transportation of spent fuel through future permanent disposal. The licensing, certification, safety inspections of waste packages, and quality assurance are integrated through NRC's licensing process. In addition, DOE interfaces directly with the spent fuel owners and HLW owners/generators. DOE has responsibility for acceptance of spent fuel from the storage site, transport to, and disposal at the proposed geologic repository. DOE has also developed acceptance criteria for DOE spent fuel and high level waste at the proposed Yucca Mountain repository. These criteria define the acceptability of waste at the proposed repository and provide requirements for treatment and conditioning of spent fuel and HLW for storage at DOE sites in preparation for acceptance at the proposed geologic repository.

---

<sup>112</sup> More specific information about the licensing process for both wet and dry storage facilities can be found at <http://www.nrc.gov/waste/spent-fuel-storage/licensing.html#site>

### **G.1.2 Avoidance of Undue Burden/Impacts on Future Generations**

The U.S. policy is to dispose of spent fuel in a geologic repository and not place undue burdens on future generations. The EPA standards for Yucca Mountain implement and reaffirm this policy to ensure future generations are protected. DOE has submitted a license application to the NRC to construct a proposed repository at Yucca Mountain, Nevada. NRC has formally docketed the Yucca Mountain license application and began its review to decide whether to grant a construction authorization to DOE. The licensing hearing will be a rigorous in-depth review of the scientific and engineering support for DOE conclusions that the repository can be constructed and operated safely and protect people far into the future, as required by EPA standards and NRC regulations.

### **G.2 Existing Facilities (Article 5)**

Independent Spent Fuel Storage Installation (ISFSI)s in the United States use over 20 different dry storage system designs (some of which are licensed for a specific site). The designs encompass the entire range of multi-purpose canisters, vault storage systems, and metal casks. These storage systems casks are made by several vendors and have been licensed or certified by NRC. Almost all ISFSIs are owned and operated by 10 CFR Part 50 power reactor license holders. See Annex D-1 for additional information.

Typical examinations for renewal of a storage license or CoC evaluate aging of components through corrosion, chemical attack, and other mechanisms for reduction in the efficacy of important storage cask components. Current guidance on renewing site-specific storage licenses or CoCs is *Preliminary Guidance For License Renewal For Site-Specific Independent Spent Fuel Storage Installations (ISFSIs)*.<sup>113</sup>

DOE operates an ISFSI at Idaho National Laboratory (INL) which stores core debris and spent fuel from the Three-Mile Island Unit-2 (TMI-2) 1979 reactor accident in Pennsylvania. There is no spent fuel remaining at TMI-2. The entire core of the TMI-2 reactor was removed, including damaged fuel and core debris and shipped to INL. Removal was started in October 1985 and completed in January 1990. TMI-2 is listed in Annex D-7 as an NRC-licensed reactor under decommissioning. The core debris and spent fuel canisters were first stored in a pool at INL. DOE received a license from NRC allowing stored canisters to be removed from the aging pool facility, dried in a heated vacuum furnace, repackaged in welded steel containers, transported, and stored in an ISFSI constructed specifically for the TMI-2 fuel debris. The TMI-2 spent fuel and debris were repackaged and moved to the ISFSI between 1999 and 2001.

### **G.3 Siting Proposed Facilities (Article 6)**

Siting of spent fuel storage installations at operating nuclear power plants is addressed within the context of the safety case associated with the operating facility. For the case of siting ISFSIs away from the operating facility or a monitored retrievable storage (MRS) facility, 10 CFR Part 72 Subpart E, *Siting Evaluation Factors*, provides the regulatory context. Subpart E addresses factors such as the radiological criteria, design basis events, geologic considerations, and control areas. Some of these considerations deal

---

<sup>113</sup> Publicly available from NRC, <http://www.nrc.gov> – ADAMS Accession Number ML010890212

with equity issues, such as not siting an MRS or an ISFSI near a candidate location for a HLW repository; no one region should bear the brunt of both. Guidance for dry storage ISFSIs is in NUREG-1567, *Standard Review Plan for Spent Fuel Dry Storage Facilities*.<sup>114</sup>

Although the U.S. Government is not currently planning to site or construct a MRS installation, a private initiative, Private Fuel Storage, LLC (PFS), submitted an application in June 1997, to NRC to construct an ISFSI designed to accept fuel from multiple utilities. This was only the second application submitted to NRC for an away-from-reactor ISFSI and the first for storage of spent fuel from more than one utility. PFS is a consortium of nuclear utilities proposing to lease land for the proposed ISFSI from the Skull Valley Band of Goshute Indians. The PFS application sought approval for the storage of a maximum of 40,000 metric tons uranium (MTU) of spent fuel at the site. The Skull Valley Band's tribal land is located southwest of Salt Lake City, Utah.

Several parties sought standing to intervene in the proceedings after the PFS application was received. The Atomic Safety and Licensing Board (ASLB), an independent judicial arm of NRC, was empanelled and several groups were granted standing. There were 45 admitted contentions, some of which were merged. These were eventually accepted by the ASLB and adjudicated. On February 25, 2005, the ASLB issued a decision on the last issue before it on the spent fuel storage facility proposed by PFS, ruling in favor of PFS. The State of Utah filed a motion for reconsideration, which was denied. NRC issued a license to PFS on February 21, 2006, but conditioned construction authorization on the company first arranging for adequate funding. On February 21, 2007, progress in developing the facility was indefinitely delayed by actions of the U.S. Department of the Interior, which has disapproved the lease arrangement between PFS and the Skull Valley Band and denied PFS the use of public lands for an intermodal transfer facility. PFS and the Skull Valley Band are challenging these actions in U.S. District Court.

The siting process for disposal in a geologic repository has a long history predating the NWPA. Several sites and geologic media were considered and screened; ultimately identifying the Yucca Mountain site for characterization for a potential geologic repository. The Secretary of Energy, the President, and the Congress designated Yucca Mountain as the site of the proposed repository pursuant to the NWPA, as amended. DOE submitted a license application to NRC on June 3, 2008, for authorization to begin construction of the repository. On September 8, 2008, NRC formally docketed the Yucca Mountain license application and initiated its full technical review.

DOE has generic siting guidelines for geologic disposal (10 CFR Part 960) and Yucca Mountain specific guidelines (10 CFR Part 963). If a future decision is made to site another geologic repository, the generic siting guidelines would apply. Future repositories for HLW and spent fuel disposal would be governed by NRC regulations (10 CFR Part 60) and EPA standards (40 CFR Part 191). These regulations prescribe required site characterization activities and pre-license application reviews by NRC. The regulations also allow states and affected Tribes to participate in the pre-licensing (site) review and licensing review. Information will be publicly available through the formal licensing docket maintained in public reading rooms by NRC.

---

<sup>114</sup> For more detailed information on spent fuel storage, see <http://www.nrc.gov/waste/spent-fuel-storage.html>



#### **G.4 Design and Construction of Spent Fuel Management Facilities (Article 7)**

NRC has three primary regulations for spent fuel management facilities, 10 CFR Part 60 and 10 CFR Part 63 for geologic disposal facilities, and 10 CFR Part 72 for storage facilities and storage casks. General design criteria contained in 10 CFR Part 72 Subpart F establish the design, fabrication, construction, testing, maintenance and performance requirements for structures, systems, and components important to safety as defined at 10 CFR 72.3. These are minimum requirements for the design criteria for an ISFSI or MRS installation.

NRC's 10 CFR Part 72 Subpart L, sets requirements for spent fuel storage cask design approval and fabrication for use by general licensees. This subpart also contains requirements/ conditions for re-approval of designs having a NRC Certificate of Compliance, record keeping and reporting requirements, procedures for amending a certificate of compliance, and periodic updating of safety analysis reports. Quality assurance requirements, which apply to both the facility and certificate holder, are in 10 CFR Part 72, Subpart G.

NRC reviews applications (safety analysis reports) using NUREG-1536, *Standard Review Plan for Dry Cask Storage Systems*, and NUREG-1567, *Standard Review Plan for Spent Fuel Dry Storage Facilities*. These plans assure the quality and uniformity of NRC application reviews.

#### **G.5 Assessment of Safety of Facilities (Article 8)**

Technical evaluations of ISFSI safety are performed in six major areas: (1) site evaluation, (2) operations systems evaluations, (3) criteria and technical design evaluation, (4) evaluation of radiation safety programs supporting protection of both worker and public health and safety, (5) evaluation of accidents, and 6) evaluation of proposed technical specifications. Additional details and specific requirements are in NUREG-1567, *Standard Review Plan for Spent Fuel Dry Storage Facilities*.<sup>115</sup>

DOE submitted a license application, accompanied by an EIS, to NRC for authorization to begin construction of a proposed repository at Yucca Mountain. The application included a general description of the repository system; proposed schedules for construction, receipt, and emplacement of waste; a physical protection plan; a material control and accounting program plan; and a description of site characterization work. The safety analysis report submitted as part of the license application included discussion of pre-closure repository safety analyses; post-closure repository safety analyses; a research and development program to resolve safety questions; a performance confirmation program; and administrative and programmatic requirements. The report included a specific description of the Yucca Mountain site and the location of the reasonably maximally exposed individual (RMEI).<sup>116</sup> Additional details of the composition of the safety analysis report can be found at 10 CFR 63.21(c).

DOE must prepare a probabilistic performance assessment to demonstrate the post-closure performance objectives specified at 10 CFR 63.113(b) are met. The performance assessment quantitatively estimates the expected annual dose to the RMEI

<sup>115</sup> NUREG-1567 can be accessed at [www.nrc.gov/reading-rm/doc-collections/nuregs/staff/](http://www.nrc.gov/reading-rm/doc-collections/nuregs/staff/)

<sup>116</sup> For additional information on RMEI see 40 CFR 197.21 and 10 CFR 63.312

will not exceed the annual dose limit of 0.15 mSv/a (15 mrem/yr) from releases from the Yucca Mountain disposal system as specified in § 63.311.<sup>117</sup> Demonstrating compliance with long-term performance requirements, by necessity, will involve the use of complex predictive models supported by data from field and laboratory tests, site-specific monitoring, and natural analog studies supplemented with prevalent expert judgment.

## **G.6 Operation of Facilities (Article 9)**

NRC applies its regulations and licensing and inspection programs to authorize storage of spent fuel or reactor related GTCC waste at an ISFSI, to approve the storage cask design, and to ensure safe operation of the ISFSI. No releases from any cask leakage or radiation safety problems have occurred since the first ISFSI became operational in 1986.

Inspections ensure safe operation and continued integrity of the fuel in the storage cask. For example, vent screens are inspected daily to ensure they are not clogged by debris, there is no damage to the storage casks, and temperature and pressure indicators are normal.

Other than review of indirect parameters there are no periodic inspections required to determine damage to the contents as part of licensing the facility. It is important to note studies have been performed on dry storage system canisters and their contents, which have been in service for many years. These studies have shown no degradation has occurred warranting changing the storage systems licensing bases.

NRC's regulations at 10 CFR 72.48 were revised on April 5, 2001, to better define the storage cask design procedures and site changes that are allowed without an amendment to license or CoC. Some control of the operational limits was shifted from the technical specifications to the Final Safety Analysis Report in implementing this rule change. The objective of this effort was to replace the current detailed technical specifications with more general standard technical specifications concentrating on controlling the parameters most important to safety. The parameters/conditions of lesser importance, which could be removed from the technical specifications via a license or certificate amendment, can be revised under the 10 CFR 72.48 process. Biennially, the licensee or certificate holder notifies NRC of the safety analysis report updates, but no review or approval by NRC is required. This analysis may be audited during routine NRC inspections.

NRC issued guidance on the standard format and content of technical specifications and recommendations on the most important fuel parameters in NUREG-1745, *Standard Format and Content for Technical Specifications for 10 CFR Part 72 Cask Certificates of Compliance*, and NUREG/CR-6716, *Recommendations on Fuel Parameters for Standard Technical Specifications for Spent Fuel Storage Casks*. The important parameters are those with a large influence on criticality safety and radiation shielding doses. The parameters are fuel type (array size, number of fuel rods, and cladding type,

---

<sup>117</sup> As discussed in Section E.2.2.2, the 0.15 mSv/a (15 mrem/yr) standard applies for the first 10,000 years. EPA has now established a 1 mSv/a (100 mrem/yr) standard for the RMEI applicable beyond 10,000 years and up to 1 million years. NRC is required by statute to make its licensing requirements consistent with EPA's standards.

and number and material of guide and instrument tubes), enrichment (maximum for criticality safety, minimum for radiation shielding) maximum burn up, minimum cooling time, maximum uranium mass, and maximum <sup>60</sup>Co level. The ultimate determination of parameters is based on those the applicant uses in its modeling to demonstrate safety of the package design.

NUREG-1745 was issued as a guide to obtain consistency in the Technical Specifications as well as to indicate to certificate holders and licensees where items could be removed from the Technical Specifications, given the appropriate actions by the applicant. A very limited number of applications used the methodology in the document to streamline their Technical Specifications.

Requirements for incident reporting are specified at 10 CFR 72.74, §72.75, and §72.80. The rules require reporting significant events where NRC may need to act to maintain or improve safety or to respond to public concerns. All events are considered against the International Nuclear Event Scale (INES). A report is generated per INES requirements if the event is classified a level 2 or above. Section F.12.3 provides additional information on operation of facilities.

#### **G.7 Disposal of Spent Fuel (Article 10)**

Spent fuel is being stored until a geologic repository is licensed and operational. Storage of spent fuel in an ISFSI is an interim action and not a final disposal solution. The U.S. Government has clearly distinguished between permanent disposal and interim storage. Nuclear power plants will continue to operate, produce power, and generate more spent fuel while the licensing decision and possible construction of the geological repository for spent fuel and HLW proceeds.

This page intentionally left blank.

## H. SAFETY OF RADIOACTIVE WASTE MANAGEMENT

Section F described common elements of spent fuel and radioactive waste safety per Articles 11-16 of the Joint Convention. This section provides additional information for the same Articles pertaining only to radioactive waste management. This section also addresses Article 17 of the Joint Convention.

The primary legal basis for activities and sites associated with the generation, storage and disposal management of radioactive waste is the Atomic Energy Act of 1954 (AEA). Under this authority and other subsequent legislation (see Table E-1), EPA has responsibility to establish generally applicable standards for the protection of the general environment from radioactive material. NRC issues regulations for activities and facilities it regulates (nuclear fuel cycle facilities, medical and research activities, etc.). DOE similarly issues orders and regulations to manage its own activities, operations, and facilities. These orders and regulations are comparable to the corresponding NRC regulations. This process is discussed in greater detail in Section E.

NRC establishes fundamental radiological protection limits in the 10 CFR Part 20, *Standards for Protection against Radiation* for the safe management of radioactive waste (or any licensed activity dealing with radioactive materials). DOE's waste management practices are in DOE Order 435.1, *Radioactive Waste Management*. This order and its implementing manual require that all DOE radioactive waste be managed to protect worker and public health and safety, and the environment. DOE Order 435.1 applies to all DOE radioactive waste classes, including HLW, TRU waste, and LLW. The requirements span the life cycle of waste management facilities from planning through decommissioning and closure. The order references other DOE requirements on radiation protection, environmental protection, and occupational safety discussed in Section F.

NRC regulates commercial radioactive waste including high-level waste (HLW), low-level waste (LLW), and uranium mill tailings. The types of radioactive materials are source, special nuclear, and byproduct material. NRC's regulatory framework for disposing and managing commercial spent fuel is described in Sections F and G. This section addresses NRC's safety requirements for LLW and uranium recovery programs. See Section B.2.3.2 for additional information on waste types.

- A. Introduction
  - B. Policies & Practices
    - Article 32, paragraph 1
  - C. Scope of Application
    - Article 3.
  - D. Inventories & Lists
    - Article 32, paragraph 2
  - E. Legislative & Regulatory Systems
    - Article 18. Implementing Measures
    - Article 19. Legislative & Regulatory Framework
    - Article 20. Regulatory Body
  - F. General Safety Provisions
    - Article 21. Responsibility of License Holder
    - Article 22. Human & Financial Resources
    - Article 23. Quality Assurance
    - Article 24. Operational Radiation Protection
    - Article 25. Emergency Preparedness
    - Article 26. Decommissioning
  - G. Safety of Spent Fuel Management
    - Article 4. General Safety Requirements
    - Article 5. Existing Facilities
    - Article 6. Siting of Proposed Facilities
    - Article 7. Design & Construction of Facilities
    - Article 8. Facility Safety Assessment
    - Article 9. Facility Operation
    - Article 10. Spent Fuel Disposal
  - H. Safety of Radioactive Waste Management**
    - Article 11. General Safety Requirements
    - Article 12. Existing Facilities & Past Practices
    - Article 13. Siting of Proposed Facilities
    - Article 14. Design & Construction of Facilities
    - Article 15. Facility Safety Assessment
    - Article 16. Facility Operation
    - Article 17. Institutional Measures After Closure
  - I. Transboundary Movement
    - Article 27.
  - J. Disused Sealed Sources
    - Article 28.
  - K. Planned Activities to Improve Safety
- Annexes

## H.1 Existing Commercial LLW Management Facilities and Past Practices (Article 12)

### H.1.1 Currently-Licensed LLW Facilities

The commercial sector's LLW is typically stored on site by licensees, either until it has decayed away (can be disposed of as ordinary trash) or until amounts are large enough for shipment to a LLW disposal site.<sup>118</sup> LLW disposal occurs at commercially operated LLW disposal facilities and could be licensed by either NRC pursuant to 10 CFR Part 61 or Agreement States pursuant to their regulations that are compatible with 10 CFR Part 61.<sup>119</sup> Facilities must be designed, constructed, and operated to meet rigorous safety standards. The operator of the facility must also extensively characterize the facility site and analyze how the facility will perform for thousands of years.

NRC regulations (10 CFR 61.12(k)) for land disposal of LLW require license applicants to submit a description of their radiation safety program for control and monitoring of radioactive effluents to ensure compliance with the radiation dose limits for the general population. Also, as required by 10 CFR 61.53(c), the licensee must maintain a monitoring program during the construction and operation of a LLW disposal facility. The monitoring system must be capable of providing early warning of releases of radionuclides from the disposal site before they leave the site boundary. Similarly, per 10 CFR 61.53(d), the licensee responsible for post-operational surveillance of the disposal site must maintain a monitoring system capable of providing early warning of releases after the site is closed.

The Low-Level Radioactive Waste Policy Amendments Act of 1985 (LLRWPA) gave states responsibility for providing disposal capacity for LLW generated within their borders. The LLRWPA encouraged states to enter into compacts allowing them to dispose of waste at a common disposal facility and exclude waste from states outside the compact. Most states have entered into compacts; however, no new compact disposal facilities have been built since the LLRWPA was passed. Figure H-1 shows the makeup of U.S. regional compacts for LLW disposal. There are now 10 compacts, comprising 42 states, and 10 unaffiliated states. The District of Columbia and Puerto Rico are considered states by the Atomic Energy Act and Low-Level Radioactive Waste Policy Amendments Act of 1985. The three existing U.S. commercial LLW disposal sites are discussed in Section D.2.2.2. All are in Agreement States.

---

<sup>118</sup>For additional information on LLW, see NUREG/BR-0216, *Radioactive Waste: Production, Storage, Disposal*, Revision 2 and NRC's fact sheet on "Low-Level Radioactive Waste".

<sup>119</sup> There are no disposal facilities currently licensed by NRC for disposal of GTCC LLW. GTCC LLW is stored until a disposal facility is established in accordance with the LLRWPA.

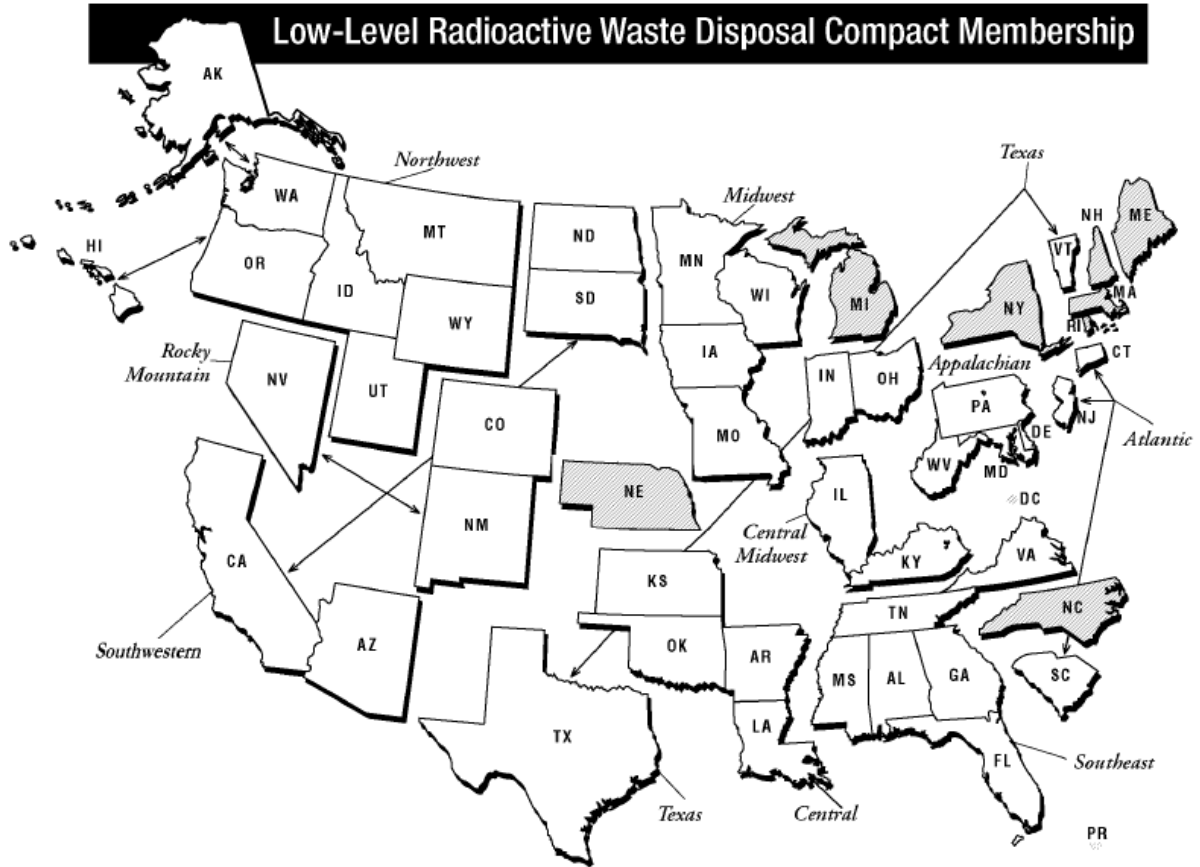

<b>Appalachian Compact</b> Delaware Maryland Pennsylvania West Virginia	<b>Northwest Compact</b> Alaska Hawaii Idaho Montana Oregon Utah Washington Wyoming	<b>Rocky Mountain Compact</b> Colorado Nevada New Mexico  <i>Northwest accepts Rocky Mountain waste as agreed between compacts</i>	<b>Southwestern Compact</b> Arizona California North Dakota South Dakota
<b>Atlantic Compact</b> Connecticut New Jersey South Carolina	<b>Midwest Compact</b> Indiana Iowa Minnesota Missouri Ohio Wisconsin	<b>Southeast Compact</b> Alabama Florida Georgia Mississippi Tennessee Virginia	<b>Texas Compact</b> Texas Vermont
<b>Central Compact</b> Arkansas Kansas Louisiana Oklahoma			<b>Unaffiliated States</b> District of Columbia Maine Massachusetts Michigan Nebraska New Hampshire New York North Carolina Puerto Rico Rhode Island
<b>Central Midwest Compact</b> Illinois Kentucky			

Figure H-1 U.S. Low-Level Waste Compacts<sup>120</sup>

<sup>120</sup>Graphic courtesy of Low Level Radioactive Waste Forum, Inc. The District of Columbia and Puerto Rico are considered States for the purpose of low-level radioactive waste disposal.

## H.1.2 Past Practices and Formerly Licensed Facilities

Because of concerns about the criteria and procedures used for the decommissioning of sites for which licenses had been terminated, NRC reviewed such sites to assure previously licensed facilities were properly decontaminated and posed no threat to public health and safety. The Oak Ridge National Laboratory (ORNL) then reviewed all terminated materials licenses to identify sites with potential for meaningful residual contamination, based on information in the license documentation, and to identify sealed sources with incomplete or no accounting, thus representing a public hazard. ORNL examined more than 37,000 terminated license files. ORNL identified about 675 material licenses and 565 sealed source licenses requiring further review. NRC either performed a follow-up review or transferred responsibility for the follow-up review to the appropriate Agreement State.

Thirty-nine formerly licensed sites were found to have residual contamination levels exceeding NRC's criteria for unrestricted release. These sites were listed in the U.S. National Report for the Second Review Meeting.<sup>121</sup> These sites are still in the process of decommissioning, under Regional review, or have been transferred to an Agreement State or other Federal agency. About 40 percent of these formerly licensed sites have since been re-released after successful remediation. See the Final Report on Results of Terminated License Reviews, dated September 26, 2001, for further details.<sup>122</sup> As in the case of the Formerly Utilized Sites Remedial Action Program (FUSRAP) sites (see Section D.3.2), some of the formerly licensed sites are being or have been addressed as part of the decommissioning of complex material sites. Annex D-6 lists the complex material sites under decommissioning authority of the NRC and the Agreement States.

In addition to the above mentioned sites, past practices in disposal of LLW led to some problems such as water buildup in the trenches (commonly called the "bathtub effect"), in large part initiated by slumping and failure of the trench caps. Such problems led to site closure at both the Maxey Flats and West Valley sites. The problems encountered at these early disposal sites, and lessons learned, prompted the development of NRC's regulation (10 CFR Part 61), focusing on the need for long-term stability of the disposal site and the waste package, as well as other disposal site suitability requirements.

## H.1.3 Management Strategies for Low Activity Waste Sites

Management and disposal of "low-activity waste" (LAW), for example, slightly contaminated solid materials, is receiving increased attention both internationally and domestically. Although the United States has no official legal definition for LAW, it is a term frequently used by other nations and organizations involved in radioactive waste management.<sup>123</sup> The National Research Council of the National Academies has recently studied this issue.<sup>124</sup> One of the primary reasons LAW has become a focus of attention is the unusually large volumes to be managed in comparison to conventional LLW from

---

<sup>121</sup> See [http://www.em.doe.gov/pdfs/Second\\_National\\_Report--Final\\_Rev\\_30.pdf](http://www.em.doe.gov/pdfs/Second_National_Report--Final_Rev_30.pdf)

<sup>122</sup> This report is available online through NRC's Agency-wide Documents Access and Management Systems (ADAMS) (Accession No. ML012710539).

<sup>123</sup> IAEA Symposium On Low-Activity Radioactive Waste Disposal; Cordoba, Spain. December 13-17, 2004

<sup>124</sup> National Academies Press, *Improving the Regulation and Management of Low-Activity Radioactive Wastes*. March 2006. <http://www.nap.edu>



the ongoing operations of nuclear facilities. Decommissioning or cleanup of contaminated sites in particular can generate large volumes of LAW.

Four Federal agencies implement or oversee cleanup programs producing substantial amounts of LAW. DOE is remediating sites previously used for its nuclear weapons program. EPA implements its Superfund program, which includes dozens of sites contaminated with radioactive materials, including a number of DOE sites. The U.S. Army Corps of Engineers is implementing the FUSRAP, addressing cleanup of sites from the Manhattan Project (see Section D.3.2). NRC established the complex sites decommissioning program in the early 1990s and continues to oversee the cleanup of sites contaminated with radioactive materials and licensees who implement the cleanup as discussed in Section D.3.3.

EPA has been considering a rule permitting the broader disposal of certain types of “low-activity” wastes in the hazardous waste facilities it regulates. As noted below, some individual facilities have accepted certain types of TENORM or exempt radioactive waste for disposal, with the approval of state authorities. EPA has also discussed LAW in the broad context of radioactive wastes containing radionuclides in small enough concentrations to allow them to be managed in ways not requiring all radiation protection measures needed for higher-activity materials.

Siting requirements for land disposal of commercial LLW are contained in Subpart D of 10 CFR Part 61. Any new sites established by state compacts under the Low-Level Radioactive Waste Policy Amendments Act of 1985 (LLRWPA) would also need to satisfy 10 CFR Part 61 siting requirements. Estimating future needs for storage or disposal capacities for LAW, LLW, or mixed waste is the waste generator’s responsibility.

Hazardous waste facilities and municipal or industrial solid waste landfills are now used by U.S. generators for some LAW disposal. Both types of facilities are regulated under RCRA, which is implemented by EPA and states authorized by EPA in the case of hazardous waste, and by states alone in the case of non-hazardous solid waste. Neither type of facility was originally designated for radioactive wastes. The same containment and isolation technology used in the design for hazardous and municipal solid waste is relied upon, in certain cases, for radioactive waste. See Section E.2.2.3 on mixed waste regulation.

Some very low activity waste (such as from decommissioning) may be disposed of in the Resource Conservation and Recovery Act of 1976 (RCRA) disposal facilities or in types of sites not licensed under the AEA. Licensees in non-Agreement States are required to get NRC approval for disposal of such very low activity waste in RCRA cells (10 CFR 20.2002). The approval request must identify amounts, concentrations, and specific radionuclides and a performance assessment demonstrating exposures will be no more than a few tens of  $\mu\text{Sv}$  (few millirem). NRC approval exempts such waste from further regulation. For example, NRC, in collaboration with the State of Michigan, permitted some very low-activity wastes from the decommissioning of the Big Rock Point nuclear power plant to be sent to a RCRA Subtitle D (solid waste) landfill. Other states, such as Texas, have also determined these landfills may offer sufficient protection for certain types of radioactive material, such as material with very short half-lives, and have included provisions in their state regulations defining the kinds and amounts of waste that can be disposed of in these facilities.

Agreement States have regulations similar to 10 CFR 20.2002. NRC provides guidance direction in the form of letters to help Agreement States evaluate such 10 CFR 20.2002 disposal requests. Some examples are STP-03-003 on *Controlled Release of Concrete*, and STP-01-081 *Case-Specific Licensing Decisions on Release of Soils from Licensed Facilities*.<sup>125</sup>

A number of DOE sites, on a case-by-case basis, in coordination with state regulators, have limited approval for waste disposal at specific solid waste landfills. The authorized limits are established to ensure no special regulatory requirements beyond those already in place for the landfill are necessary.

LAW from remediation of sites and decommissioning is also affected by risk management decisions for the release of sites. LAW from contaminated sites may be allowed to remain onsite under certain circumstances, often after the more highly radioactive materials have been removed. DOE plans to leave residual radioactivity in place at many sites, and will require long term management (institutional controls) to ensure future use of the land is safe and barriers are functioning as intended. Several DOE sites have waste disposal onsite in CERCLA disposal cells requiring long-term stewardship. See Section D.2.2.2.

The Superfund program administered by EPA has a long history of permitting residual materials, both chemicals and radioactive materials, to remain on site provided a reliable system of institutional controls is established. CERCLA requires a review every five years to ensure the controls are continuing to function.

#### **H.1.4 Controlling Disposition of Solid Materials**

Currently, NRC generally addresses the release of solid material on a case-by-case basis using license conditions and existing regulatory guidance. In each case, material may be released from a licensed operation with the understanding and specific acknowledgment that the material may contain very low amounts of radioactivity, but that the concentration of radioactive material is so small that its control through licensing is no longer necessary. Some materials are only contaminated on or near the surface; others are contaminated throughout their volume. The regulatory processes for release of these materials are different.

Land disposal is another option for disposition of low activity radioactive material from licensed facilities (Section H.1.3). NRC can consider specific licensing actions, as well as generic requests, concerning the disposition of solid materials. NRC regulations do not contain generally applicable standards for the disposition of solid materials with relatively small amounts of radioactivity in, or on, materials and equipment. The offsite disposition of solid materials prior to license termination will continue to be evaluated on a case-by-case basis using existing guidance.

---

<sup>125</sup> See <http://nrc-stp.ornl.gov/asletters/>

#### H.1.4.1 Surface Contaminated Radioactive Material Release

Criteria used by licensees to determine whether the material may be released are approved during the initial licensing or license renewal of a facility, as part of the facility's license conditions or radiation safety program. The licensees' actions must be consistent with the requirements of 10 CFR Part 20 (e.g., 10 CFR 20.1501). Thus, the licensee performs a survey of the material prior to its release. However, there are differences in the way reactor licensees and materials licensees apply the criteria for release of this material.

Nuclear reactor licensees historically follow a policy that was established and documented in NRC Office of Inspection and Enforcement Circular 81-07 and Information Notice 85-92.<sup>126</sup> The reactor licensees survey equipment and material before its release to identify the presence of controlled radioactive material above natural background levels; if this "presence" is detected, then no release may occur.<sup>127</sup> Otherwise, the solid material in question can be released for unrestricted use.

For materials licensees, NRC usually authorizes the release of solid material through specific license conditions. One set of criteria that is used to evaluate solid materials before they are released is contained in Regulatory Guide 1.86, *Termination of Operating Licenses for Nuclear Reactors*.<sup>128</sup> A similar guidance document is Fuel Cycle Policy and Guidance Directive FC 83-23, *Guidelines for Decontamination of Facilities and Equipment Prior to Release for Unrestricted Use or Termination of Byproduct, Source or Special Nuclear Materials Licenses*. Both documents contain a table of surface contamination criteria which may be applied by licensees for use in demonstrating that solid material with surface contamination can be safely released with no further regulatory control. These surface contamination criteria have been used in many contexts for all types of licensees for many years.

#### H.1.4.2 Volumetrically Contaminated Radioactive Material Release

NRC has not provided generic guidance for unrestricted release of volumetrically contaminated materials. These situations are addressed on an individual basis, typically seeking to assure, by an evaluation of doses associated with the proposed release of the material, that maximum doses are a small percentage of the 10 CFR Part 20 dose limit for members of the public (i.e., 1 mSv/a). The practice over the years has been to allow the release of material with slight levels of volumetric contamination based on a case-by-case evaluation. These evaluations follow guidance discussed in a number of NRC documents.<sup>129</sup>

---

<sup>126</sup> These documents are available from NRC's website: Information Notice No. 85-92: Surveys Of Wastes Before Disposal From Nuclear Reactor Facilities (December 2, 1985) <http://www.nrc.gov/reading-rm/doc-collections/gen-comm/info-notices/1985/in85092.html>, and IE Circular No. 81-07: Control Of Radioactively Contaminated Material (May 14, 1981) <http://www.nrc.gov/reading-rm/doc-collections/gen-comm/circulars/1981/cr81007.html>.

<sup>127</sup> The fact that no radioactive material above background is detected does not mean that none is present; there are limitations on detection capability. In practice, the actual detection capability of survey instruments is typically consistent with the criteria in NRC Regulatory Guide 1.86.

<sup>128</sup> Available at <http://www.nrc.gov/reading-rm/doc-collections/reg-guides/power-reactors/active/01-086/01-086.pdf>

<sup>129</sup> NRC All-Agreement States letters (STP-00-070 [<http://nrc-stp.ornl.gov/asletters/program/sp00070.pdf> dated August 22, 2000], STP-01-081 [<http://nrc-stp.ornl.gov/asletters/program/sp01081.pdf> dated November 28, 2001], STP-03-003 [<http://nrc-stp.ornl.gov/asletters/program/sp03003.pdf> dated January 15, 2003]).

Reactor facilities release volumetrically contaminated materials under the provisions of Information Notice No. 88-22, *Disposal of Sludge from Onsite Sewage Treatment Facilities at Nuclear Power Stations*.<sup>130</sup> Certain materials may be surveyed using a representative sample and gamma spectrometry analytical methods. The provision requires that materials can be released if no licensed radioactive material above natural background levels is detected, provided the radiation survey used a detection level that is consistent with the lower limit of detection (LLD) values used to evaluate environmental samples. There are several different acceptable survey applications of the environmental LLDs and applications have included a variety of environmental media including soils, sediments, liquids and slurries.<sup>131</sup>

Materials licensees release volumetrically contaminated materials under the provisions of the December 27, 2002, NRC Memorandum *Update on Case-Specific Licensing Decisions on Controlled Release of Concrete from Licensed Facilities*.<sup>132</sup> (This memorandum indicates that controlled releases of volumetrically contaminated concrete may be approved, pursuant to 10 CFR 20.2002, under an annual dose criterion of a “few mrem” (few 10s of  $\mu\text{Sv}$ .)

## **H.2 DOE Waste Management Facilities**

General safety requirements for DOE facilities were discussed in Section F (Article 11). The following subsections contain additional information on the safety of radioactive waste management at DOE facilities.

DOE manages radioactive waste from government-sponsored programs including waste from defense activities and cleanup of former defense waste sites. DOE Order 435.1 is implemented through Manual 435.1-1, including procedural requirements and existing practices ensuring all waste is managed to protect workers, the public, and the environment.

### **H.2.1 Past Practices (Article 12)**

Environmental restoration activities using the CERCLA process must demonstrate compliance with the substantive requirements of DOE Order 435.1, including the performance objectives. The CERCLA process can be used for this demonstration if it is adequate. Compliance with all substantive requirements of DOE Order 435.1 not met through the CERCLA process must be separately demonstrated, however. See Section F.7.5 for additional information.

Some past practices have led to environmental restoration activities or interventions. Former waste disposal techniques, such as soil columns or crib trenches, and decontamination of sites where remaining residual radioactivity does not meet today’s standards for unrestricted release are some examples.

Environmental restoration activities resulting in off-site management and disposal of radioactive waste must meet the applicable requirements of DOE Order 435.1. Organizations performing environmental restoration activities, involving development

---

<sup>130</sup> See <http://www.nrc.gov/reading-rm/doc-collections/gen-comm/circulars/1988/in88022.html>

<sup>131</sup> See NRC Regulatory Guide 4.8, *Environmental Technical Specifications for Nuclear Power Plants*.

<sup>132</sup> See <http://nrc-stp.ornl.gov/asletters/program/sp03003.pdf>

and management of radioactive waste disposal facilities under the CERCLA process, submit a certification of compliance with the substantive requirements of DOE Order 435.1. They also submit the decision document, such as the Record of Decision, or any other document used as a basis for authorization for disposal. Section H.2.4 provides additional requirements for closure of waste management facilities, some of which may be attributed to past practices. DOE cleanup activities are described further in Section D. Cleanup now reduces potential impacts on future generations.

### **H.2.2 Siting Proposed Facilities (Article 13)**

In addition to the requirements in DOE Order 435.1, radioactive waste management facilities, operations, and activities are designed and sited in accordance with DOE Order 420.1A, *Facility Safety*, and DOE Order 430.1B, *Real Property Asset Management*.<sup>133</sup> Proposed locations for radioactive waste management facilities are evaluated to identify features to be avoided or must be considered in facility design and analyses. Criteria were developed for siting a spent fuel and HLW geologic repository in 10 CFR Part 960, as well as potentially adverse conditions specified by NRC at 10 CFR 60.122. Criteria for siting a proposed new facility or expansion of an existing facility must consider:

- Environmental and Geotechnical suitability;
- Human Activity prohibiting site use;
- Suitability for the volume of proposed waste disposal;
- Presence of flood plain, tectonic, or water table fluctuation characteristics; and
- Ability to control radionuclide migration pathways, surface erosion and runoff.

### **H.2.3 Design and Construction (Article 14)**

Safety structures, systems, and components for high-level waste storage, pretreatment, and treatment facilities are designated and designed consistent with the provisions of DOE Order 420.1A, and nuclear safety regulations (10 CFR Part 830). Generally applicable requirements and procedures for nuclear facility design, construction and operation are in 10 CFR Part 830, *Nuclear Safety Management*; DOE Policy P 450.4, *Safety Management System Policy*; and DOE Acquisition Regulation clauses at 48 CFR 970.5223-1, 48 CFR 970.5204-2, and 48 CFR 970.1100-1.

DOE Radioactive Waste Management Manual 435.1-1, requires new or modified waste management facilities subject to contamination with radioactive or other hazardous materials be designed to facilitate decontamination. A proposed decommissioning method must be included in the design.

### **H.2.4 Assessment of Safety of Facilities (Article 15)**

Radioactive waste facilities, operations, and activities must have a radioactive waste management basis consisting of physical and administrative controls to ensure protection of workers, the public, and the environment.

---

<sup>133</sup>DOE orders apply to DOE waste facilities; they do not apply to facilities owned and operated by commercial firms, e.g., commercial LLW facilities subject to licenses issued by NRC or Agreement States.

Specific waste management controls are part of the radioactive waste management basis for:

- Waste generator organizations (the waste certification program);
- Pretreatment and treatment facilities (the waste acceptance criteria and waste certification program);
- Storage facilities (the waste acceptance criteria and the waste certification program); and
- LLW and TRU waste disposal facilities (the performance assessment, composite analysis, disposal authorization statement, closure plan, waste acceptance requirements, and monitoring plan).

A composite analysis must account for all sources of radioactive material from any DOE facility contributing to the projected long-term dose to a hypothetical member of the public from an active or proposed low-level waste disposal facility. The analysis is a planning tool to provide a reasonable expectation current low-level waste disposal activities will not result in the need for future corrective or remedial actions. Additional information is in the implementation guidance for DOE Order 435.1 (DOE G 435-1). More details on this guidance are available on the internet.<sup>134</sup>

DOE LLW disposal facilities are sited, designed, operated, maintained, and closed so there is a reasonable expectation the following performance objectives are met for waste disposed of after September 26, 1988:

- Dose<sup>135</sup> to representative members of the public does not exceed 0.25 mSv (25 mrem ) in a year from all exposure pathways, excluding the dose from radon and its progeny in air;
- Dose to representative members of the public via the air pathway does not exceed 0.10 mSv (10 mrem) in a year total effective dose equivalent, excluding the dose from radon and its progeny; and
- Release of radon is less than an average flux of 0.74 Bq/m<sup>2</sup>/s (20 pCi/m<sup>2</sup>/s) at the surface of the disposal facility; alternatively, a limit of 0.0185 Bq/l (0.5 pCi/l) in air may be applied at the boundary of the facility.

Site-specific radiological performance assessments were prepared and are maintained for DOE LLW disposed of after September 26, 1988. The performance assessments include calculations for a 1,000-year period after closure of potential doses to representative future members of the public and potential releases from the facility to provide a reasonable expectation the performance objectives above are not exceeded as a result of operation and closure of the facility. This time was selected to encompass the likely processes and migration of radionuclides most likely to contribute to the calculated dose. Longer times are not used to assess compliance with numerical standards because of the inherently large uncertainties in extrapolating such calculations over long time frames. Although the period of performance is 1,000 years, sensitivity/uncertainty analysis is extended to peak dose to increase understanding of the models used and the disposal facility performance.

---

<sup>134</sup> See <http://www.directives.doe.gov/>

<sup>135</sup> Dose is defined here as the total effective dose equivalent, which is defined as the sum of the deep-dose equivalent for external exposures and the committed effective dose equivalent for internal exposures.

Analyses performed to demonstrate compliance with the performance objectives, and to establish limits on concentrations of radionuclides for disposal based on the performance measures for inadvertent intruders are based on reasonable activities in the critical group of exposed individuals. The assumption of average living habits and exposure conditions in representative critical groups of individuals projected to receive the highest doses is appropriate unless otherwise specified. The likelihood of inadvertent intruder scenarios may be considered in interpreting the results of the analyses and establishing radionuclide concentrations, if adequate justification is provided.

The point of compliance corresponds to the point of highest projected dose or concentration beyond a 100 meter buffer zone surrounding the disposed waste. A larger or smaller buffer zone may be used if adequate justification is provided.

Performance assessments address reasonably foreseeable natural processes disrupting barriers against release and transport of radioactive materials. These assessments use DOE-approved dose coefficients (dose conversion factors) for internal and external exposure of reference adults, and include a sensitivity/uncertainty analysis. Performance assessments include demonstrating that projected releases of radionuclides to the environment are maintained ALARA; and include an assessment of impacts to water resources to establish limits on radionuclides disposed of near the surface.

To establish limits on the concentration of radionuclides disposed of near surface, the performance assessment also includes an assessment of impacts calculated for a hypothetical person assumed to inadvertently intrude for a temporary period into the LLW disposal facility. There is no maximum active institutional control period for DOE near-surface disposal facilities, or on the applicability of DOE's radiation protection criteria. Concerning radiation protection, the only consideration is whether risks may eventually be sufficiently low to no longer warrant continued protection. But in most cases, because of the nature of the hazard and statutory requirements, DOE, or successor agencies, may be required to maintain control permanently. However, for purposes of analyzing hypothetical inadvertent intrusion, institutional controls are assumed to be effective in preventing intrusion for at least 100 years. Longer periods may be assumed with case-specific justification. The intruder analyses use performance measures for chronic and acute exposure scenarios, respectively, of 1 mSv (100 mrem) in a year and 5 mSv (500 mrem) total effective dose equivalent excluding radon in air.

In addition to performance assessments, site-specific radiological composite analyses are prepared and maintained for LLW disposal facilities receiving waste after September 26, 1988. The composite analysis accounts for all sources of radioactive material left at DOE sites potentially interacting with the LLW waste disposal facility, contributing to the dose projected to a hypothetical member of the public from existing or future disposal facilities. Performance measures are consistent with DOE requirements for protection of the public and environment and evaluated for a 1,000-year period following disposal facility closure. The composite analysis results are used for planning, radiation protection activities, and future use commitments to minimize the likelihood current LLW disposal activities will result in the need for future corrective or remedial actions.

The performance assessment and composite analysis are maintained to evaluate changes affecting the performance, design, and operating bases for the facility.

Performance assessment and composite analysis maintenance includes research, field studies, and monitoring needed to address uncertainties or gaps in existing data. The performance assessment is updated to support the final facility closure. Additional iterations of the performance assessment and composite analysis are conducted as necessary during the post-closure period. Performance assessments and composite analyses are reviewed and revised when significant changes alter the conclusions or the conceptual model(s). A determination of the continued adequacy of the performance assessment and composite analysis is made on an annual basis, and considers the results of data collection and analysis from research, field studies, and monitoring. Annual summaries of LLW disposal operations describe the conclusions and recommendations of the performance assessment and composite analysis and present a determination of the need to revise the performance assessment or composite analysis.

A disposal authorization statement is a part of the radioactive waste management basis for a disposal facility and is obtained prior to construction of a new LLW disposal facility. DOE sites with existing LLW disposal facilities obtained a disposal authorization statement in accordance with the schedule in the *Complex-Wide Low-Level Waste Management Program Plan*.<sup>136</sup> The disposal authorization statement is issued based on a review of the facility's performance assessment, composite analysis, preliminary closure plan, and preliminary monitoring plan. The disposal authorization statement specifies the limits and conditions on construction, design, operations, and closure of the LLW facility based on these reviews.

Disposal Facility Closure Plans are developed for DOE LLW disposal sites. A preliminary closure plan is developed and reviewed with the performance assessment and composite analysis. The closure plan is updated following the disposal authorization statement to incorporate conditions specified in the disposal authorization statement. Closure plans are updated as required during the operational life of the facility. They include a description of how the disposal facility will be closed to achieve long-term stability, minimize the need for active maintenance following closure, and ensure compliance with the requirements of DOE Order 5400.5, *Radiation Protection of the Public and the Environment*. Closure plans also include the total expected inventory of wastes to be disposed of at the facility over the operational life of the facility.

Closure of a DOE LLW disposal facility occurs within a 5-year period after it is filled to capacity, or after determining the facility is no longer needed. The final inventory of the LLW disposed in the facility is prepared and incorporated in the performance assessment and composite analysis, which is updated to support the closure of the facility prior to closure. A final closure plan is prepared and implemented based on the final inventory of waste disposed in the facility. An updated performance assessment and composite analysis are prepared in support of the facility closure.

---

<sup>136</sup>Referenced in DOE Order 435.1.



## H.2.5 Facilities Operation

DOE policy requires radioactive waste to be treated, stored, and in the case of LLW, disposed of at the site where the waste is generated, if practical, or at another DOE facility. Commercial treatment and storage are allowed if DOE capabilities are not practical or cost effective. The United States has no “long-term” LLW storage facilities. Some waste for which DOE is currently evaluating the appropriate disposition path, such as disused sealed sources that were GTCC LLW when in the possession of NRC’s licensees, remains in storage until DOE decides on the appropriate disposal. Disposal of DOE LLW at non-DOE sites requires an exemption showing non-DOE facilities comply with provisions such as:

- Adherence to applicable Federal, state, and local requirements;
- Annual audits by DOE approved personnel;
- Protection of public health and the environment; and
- Demonstration of performance objectives.

DOE M 435.1-1 references about 25 safety-related DOE orders applying generally to radioactive waste management facilities, operations, and activities. DOE M 435.1-1 also provides specific limits and criteria for HLW, TRU waste, and LLW storage, treatment and disposal. These include disposal limits and criteria for total public dose, air pathway dose, radon releases, and intruder protection. NRC and EPA additionally specify detailed requirements for of LLW, uranium and thorium mill tailings, TRU waste, spent fuel, and HLW disposal. See Section E additional information.

## H.2.6 Institutional Measures after Closure

Institutional control measures are integrated into land use and stewardship plans and programs, and continue until the facility can be released pursuant to DOE Order 5400.5, *Radiation Protection of the Public and the Environment*. Chapter IV of DOE Order 5400.5 requires, whenever property is released from radiological control, doses to the public to be below dose constraints and optimized to be as low as reasonably achievable. The dose constraint is 0.25 mSv/a for unrestricted release. Most radioactive waste disposal sites will not meet DOE criteria for unrestricted release at any time in the foreseeable future. The location and use of the facility is filed with the local authorities responsible for land use and zoning.

Active and passive institutional controls must be maintained until risks are sufficiently low such that continued protection would not be necessary. The active control period is determined by public risk, and some sites may indeed be released for either controlled or uncontrolled use. But in most cases, because of the nature of the hazard and statutory requirements, DOE, or successor agencies, may be required to maintain control permanently. DOE Policy 454.1 requires the maintenance of active and passive controls for as long as the hazard exists. DOE anticipates many of its facilities may never be released from active institutional control.

DOE will use active institutional controls for at least 100 years following closure. Active controls, such as fences, roadways, signs, and periodic surveillance, prevent human intrusion during this period. Ground water monitoring will continue for at least 30 years after closure, and subsidence monitoring will continue for at least 100 years. To

eliminate potential overlap with hazardous waste (RCRA) requirements, EPA required post-closure monitoring be complementary with RCRA, so information yielded by the one monitoring program would not be duplicated by the other. In its compliance application to EPA for certification, DOE proposed these timeframes, consistent with the RCRA requirements with which it was also required to comply.

Regulations require that TRU waste disposal sites have markers and controls to inform and warn future generations about the location and purpose of this repository after the active institutional control period. These passive controls are expected to communicate the location, design, and contents of the disposal system for at least 10,000 years. Planned components include: a large earthen berm, perimeter monuments, buried warning markers, magnets and metal radiation symbols, an information center using graphics and various languages, and information storage rooms. Archives will be stored in various locations around the world. A summary report is planned, and will be written in multiple languages on archival-quality paper to preserve it. While the institutional controls are intended to remain in effect for the entire 10,000 year regulatory time, it is not a "regulatory safety requirement" they be effective for that long. The only "requirement" is to have institutional controls. EPA has allowed WIPP no credit toward radiation control or reduction of exposure for the long-term active institutional controls (beyond 100 years), and they have not been taken into account quantitatively.

Current planning as required for EPA certification in compliance with 10 CFR Part 194 is as follows. For the first 100 years after closure of the repository, arrangements will be made with local law enforcement to restrict any subsurface intrusion within the withdrawn area. In addition, for the first 300 years, records will be maintained and maintenance will be performed on the permanent markers. After 300 years, only passive controls are currently planned at the repository site. Records will be maintained at a U.S. Government National Archives Facility beyond 300 years. The markers will be designed to last an estimated 700 years.<sup>137</sup>

DOE's license application to NRC for the proposed repository at Yucca Mountain, Nevada, describes preliminary concepts for permanent warning monuments or markers on the mountain's surface. NRC requires that the monuments or markers "accurately identify the location of the repository, be designed to be as permanent as practicable and convey a warning against intrusion into the underground repository, because of risk to public health and safety from radioactive wastes." Current concepts include both monuments and markers, but the designs will not be final for some time because they will not be approved by NRC until shortly before the repository is to be permanently sealed and closed. Figure H-2 depicts an artist's conception of one of the large warning monuments being proposed that would serve as information centers on the crest of Yucca Mountain. These would be part of a wider monument placement scheme to inform the public about Yucca Mountain.

---

<sup>137</sup> Reference Report DOE/WIPP 04-2301, section 3.2, pages 10-15 on Records Management and section 3.4, pages 22-31 for permanent markers. In addition, reference DOE/WIPP 04-3302, *Permanent Markers Implementation Plan*.



Figure H-2 Conceptual Yucca Mountain Warning Monument

### H.3 Uranium Recovery Wastes

Uranium milling is any activity resulting in the production of byproduct material. 10 CFR Part 40 defines byproduct material the same as Section 11e.(2) of the Atomic Energy Act, "...the tailings or wastes produced by the extraction or concentration of uranium or thorium from any ore processed primarily for its source material content," but adds "...including discrete surface wastes resulting from uranium solution extraction processes." This section deals with safety practices; Section D.2.2.3 provides a description of uranium recovery facilities in the United States.

#### H.3.1 General Safety Requirements (Article 11)

The general radiological waste safety provisions, as well as for siting and closure, for uranium milling activities are addressed in 10 CFR Part 40, with specific criteria described in Appendix A, *Criteria Relating to the Operation of Uranium Mills and the Disposition of Tailings or Wastes Produced by the Extraction or Concentration of Source Material from Ores Processed Primarily for Their Source Material Content*. The criteria in Appendix A cover the siting and design of tailings impoundments, disposal of tailings or wastes, decommissioning of land and structures, ground water protection standards, and testing of the radon emission rate from the impoundment cover. The criteria also include monitoring programs, airborne effluent and off-site exposure limits. The criteria also cover inspection of retention systems, financial surety requirements for decommissioning and long-term surveillance and control of the tailings impoundment, and eventual government ownership of the tailings site under a NRC general license.

A number of non-radiological constituents (e.g., ammonia, arsenic, and heavy metals) contained in tailings present a potential human health and environmental hazard to ground water and surface waters. Table 5C in 10 CFR Part 40, Appendix A contains maximum concentration limits for ground water protection for 14 non-radiological constituents and for radium and gross alpha. NRC considers all ground water contamination from licensed uranium mill activities to be classified as 11e.(2) byproduct material regulated under the Atomic Energy Act. This includes radiological and non-radiological constituents. Remediation standards are made on a site-specific basis and licensees can propose as their ground water protection standards: (1) background values, (2) maximum concentration limits per Table 5C, or (3) alternate concentration

limits presenting no significant hazard and are ALARA after considering practicable corrective actions. Compliance is assessed and assured by review of licensee monitoring and NRC inspections.

EPA regulations provide generally applicable mill standards, which NRC adopted in its regulations for uranium milling. The Office of Surface Mining, U.S. Department of Interior and individual states regulate mining safety as an industrial, non-nuclear activity (i.e., uranium mining is not regulated as part of the nuclear fuel cycle). EPA also issues regulations and standards to direct the actions of other Federal agencies. NRC regulates milling and the disposal of tailings in non-Agreement States; although state agencies regulate these activities in Agreement States when the agreement specifically includes tailings. NRC requires licensees to meet EPA standards for cleanup of uranium and thorium mill sites after the milling operations have permanently closed. This includes requirements for long-term stability of the mill tailings piles, radon emissions control, water quality protection and cleanup, and cleanup of lands and buildings. The annual occupational dose limit for both mines and mills is 50 mSv (5 rem).

### **H.3.2 Existing Facilities/Past Practices (Article 12)**

The existing facilities are considered UMTRCA Title I (closed or abandoned by 1978) or Title II (licensed in 1978 or later). Reclamation at Title I facilities is largely complete with the exception of the former Atlas site near Moab, Utah; however, groundwater issues remain to be resolved at a few sites. Most of the Title II facilities in the United States are in decommissioning, and either have completed, or are completing, reclamation activities. The goal of the reclamation activities is to provide long-term stabilization and closure of the tailings impoundments and the sites. See Section D.2.2.3 for additional information.

NRC or the Agreement State inspects these sites at various intervals depending on the operational (or stand-by) and reclamation status. The inspection frequency can range from multiple times per year at an operating facility to once every three years at a facility in standby or reclamation status. Annex D-3A and D-3B provide status of uranium recovery facilities.

### **H.3.3 Uranium Recovery Radioactive Waste Management Facilities: Siting, Design and Construction (Articles 13 and 14)**

Appendix A to 10 CFR Part 40 has 13 criteria for the siting, design, construction, operation, termination and post-closure provisions.<sup>138</sup> Technical Criterion 1 sets broad objectives for siting and design. The intent is to provide permanent isolation of tailings and associated contaminants by minimizing disturbance and dispersion by natural forces, and to do so without ongoing maintenance. Additional criteria specify period of performance (longevity) and other design considerations such as the presence of a liner system and dewatering method. Construction considerations include the preference for below grade disposal and reliance on a full self-sustaining vegetative cover or rock cover to reduce wind and water erosion to negligible levels.

---

<sup>138</sup>These criteria can be accessed at <http://www.nrc.gov/reading-rm/doc-collections/cfr/part040/part040-appa.html>

### **H.3.4 Uranium Recovery Radioactive Waste Management Facilities: Safety Assessment (Article 15)**

A safety assessment is performed as part of the application review process for a uranium recovery operation. The application must provide detailed information on facilities, procedures, and equipment. The licensee must provide an environmental report with sufficient information for NRC to prepare an environmental assessment (under the provisions of NEPA – See Table E-1) as significant changes occur during the life of the facility, e.g., expansion of the tailings pile or increasing the number of ISL well fields. This information is used by NRC staff to determine if proposed activities are protect public health and the environment. An environmental assessment (EA) is prepared as part of this process. A more complete EIS is prepared by NRC if the EA identifies potential significant environmental impacts. The licensee may, as a result of EIS, have to revise the design and/or increase the financial assurance mechanism, guaranteeing adequate funding for closure and disposal.

### **H.3.5 Uranium Recovery Radioactive Waste Management Facilities: Institutional Measures after Closure (Article 17)**

Uranium recovery licensees are required by license conditions to complete site decontamination, decommissioning, and surface and groundwater remedial actions consistent with decommissioning, reclamation, and groundwater corrective action plans before license termination.<sup>139</sup> Licensees must document the completion of these remedial actions in accordance with NRC procedures. This information includes a report documenting completion of tailings disposal cell construction, as well as radiation surveys and other information required by 10 CFR Part 40.42.

In 10 CFR Part 40, Appendix A, Criterion 12 it is stipulated that final design of the waste impoundment, i.e., the final disposition of tailings, residual radioactive material, or wastes at milling sites, should assure ongoing active maintenance is not necessary to preserve isolation. A monetary mechanism is specified to ensure surveillance and monitoring continue, but active ongoing maintenance should not be needed because of the robust impoundment design required by other criteria.

No reliance is placed on active institutional controls. However, per 10 CFR Part 40 (byproduct material) long-term custody and surveillance institutional controls are required in perpetuity.

The licensee will work with the custodial agency in preparing the Long Term Surveillance Plan (LTSP) because the LTSP must reflect the remediated condition of the site. The LTSP must include, among many safety-related provisions: a description of the long-term surveillance program, including proposed inspection frequency and the frequency and extent of ground water monitoring if required, appropriate constituent concentration limits for ground water, inspection personnel qualifications, inspection procedures, record keeping, and QA procedures. Coordination between the custodial agency and the licensee will likely involve supplying the custodial agency with appropriate documentation such as as-built drawings of the remedial actions taken and reaching agreements (formal or informal) with the custodial agency on the necessary surveillance control features of the site (boundary markers, fencing). It is the responsibility of the

---

<sup>139</sup>NUREG-1814, *Status of the Decommissioning Program: 2004 Annual Report*, January 2005.

custodial agency to submit the LTSP to NRC for approval and acceptance. The licensee may, however, elect to help prepare the LTSP, to whatever degree is agreed upon between the licensee and the custodial agency. The law provides for DOE, the state, or under some circumstances, a third party to become the custodial agency.

When the current specific license is terminated and NRC accepts the LTSP, the custodial agency becomes a general licensee per 10 CFR 40.28(a). There is no termination of this general license. Custodial agencies are required, under 10 CFR 40.28(c)(1) and (c)(2), to implement the provisions of the LTSP. The license termination process is discussed in more detail in Section E3.0 of NUREG-1620.<sup>140</sup>

Prior to transfer of custody, the specific licensee provides funding to cover long-term surveillance responsibilities in accordance with Criterion 10 of Appendix A. NRC will determine the final amount of this charge based on final conditions at the site. The remaining liability of the licensee after termination of the existing license and transfer of the site and byproduct materials to the custodial agency, extends solely to any fraudulent or negligent acts committed before the transfer to the custodial agency, as provided for in Section 83b(6) of the AEA.

Section 83 of the AEA, as amended, requires that before termination of the specific license, title to the site and byproduct materials should be transferred to (a) DOE, (b) a Federal agency designated by the President, or (c) the state in which the site is located, at the option of the state. DOE will be the custodial agency for most, if not all, of the sites.

#### **H.4 Monitoring Releases to the Environment**

RadNet, formerly known as the Environmental Radiation Ambient Monitoring System (ERAMS), is a national network of more than 200 monitoring stations distributed across all 50 states and the American Territories. Each station regularly samples the nation's air, precipitation, drinking water, or pasteurized milk for a variety of radionuclides (e.g., <sup>131</sup>I) and radiation types (e.g., gross beta).

RadNet includes:

- 76 newly-installed fixed air monitors that can deliver real-time data through satellite telemetry;
- 40 older non-real-time fixed air monitors;
- 40 portable (or "deployable") real-time air monitors;
- 37 milk sampling locations;
- 44 precipitation sampling locations; and
- 77 drinking water sampling locations.

EPA intends to expand the fixed network of air monitors significantly over the next several years. These plans include the gradual replacement of the older non-real time monitors with the upgraded real-time monitors. The 40 deployable air monitors are maintained at EPA's radiation laboratories in Montgomery, Alabama and Las Vegas, Nevada.

---

<sup>140</sup> NUREG-1620, Revision 1, *Standard Review Plan for the Review of a Reclamation Plan for Mill Tailings Sites under Title II of the Uranium Mill Tailings Radiation Control Act*, June 2003.

The legal basis of RadNet originated in Executive Order 10831, issued by President Dwight D. Eisenhower in 1959, and was restated as part of the legislative history of the 1959 amendments to the AEA. Radioactive fallout and environmental radiation monitoring became the responsibility of the Department of Health, Education and Welfare (HEW) under these legal mandates. HEW transferred these responsibilities to EPA in 1970.

These responsibilities are described in EPA Order 1110.2, in which EPA "...shall develop programs and systems for monitoring the condition of the environment which are integrated with monitoring activities of other Federal and non-Federal agencies." EPA established its monitoring network in 1973, by consolidating components of existing radiation monitoring networks, including the Radiation Alert Network, the Tritium Surveillance System, the Interstate Carrier Drinking Water Network, and the Pasteurized Milk Network. The responsibility for operating RadNet is now assigned to the Director of the National Air and Radiation Environmental Laboratory, Montgomery, Alabama.

Since its establishment, RadNet has collected over a half million high quality environmental samples. The current database primarily provides data collected since 1978. Some older "pre-ERAMS" data are included.<sup>141</sup>

RadNet normally operates in a "routine" mode, sampling radiation in all media on a regularly defined schedule. RadNet operates in an "emergency" (or alert) mode in a threat of a significant radiation release, accelerating the frequency of sampling and generating many more data records for a given period of time compared to the RadNet routine mode. This has been done as recently as in 2000 following wildfires at Los Alamos National Laboratory and Hanford Reservation and in 2001 following the terrorist attacks in the United States.

As noted above, the air monitoring portion of the RadNet system is currently being upgraded and expanded to better serve emergency response scenarios. This expansion responds to the recent emphasis on homeland security since, in the early stages of a radiological incident, air is the most likely exposure pathway.

By adding new air monitoring stations across the country with the enhanced capability to detect and rapidly report environmental levels of radiation, EPA will provide public officials information to help them determine if and where additional assessments may be needed. EPA has developed a strategy to place the new fixed station monitors in locations ensuring improved national coverage from both a population and geographic standpoint. The monitors will continue to be operated by volunteers.

The expanded RadNet system will provide information to help evaluate the degree and extent of contamination caused by an accidental release or a terrorist incident. The upgrades will include:

- Air monitors automatically transmitting near-real-time data;

---

<sup>141</sup> RadNet data and instructions for viewing reports are available through the RadNet home page at <http://www.epa.gov/enviro/html/erams/index.html>

- The additional placement of monitors to improve national coverage; and
- Air monitors with the capability of being deployed after an accident or terrorist event involving radioactive materials, to allow earlier and more comprehensive coverage of the affected areas to assist in response activities and decision-making.

EPA is developing an interactive desktop tool to provide officials with information about radiation monitoring stations across the country. RadMap employs a GIS interface to allow the user to collect information about the network of Federal, state, local, and industrial/commercial monitors, including points of contact, available data, data collection parameters and frequency, demographics, and geographic points of interest. RadMap was conceived as a particularly useful tool for emergency responders to help assess situations and determine the need for and appropriate location of additional monitoring resources. As a desktop application, RadMap ensures access to critical information even if computer network capabilities are unavailable.



## I. TRANSBOUNDARY MOVEMENT

### I.1 Overview of U.S. Legal and Policy Framework Governing the Transboundary Movement of Radioactive Waste and Spent Fuel

DOE has independent authority for imports and most exports under the Atomic Energy Act of 1954 (AEA). Thus, DOE imports and most exports are not subject to NRC regulations.

The AEA assigns regulatory oversight responsibility to NRC for commercial imports and exports of source, special nuclear and byproduct materials to and from the United States.<sup>142</sup> NRC regulations governing commercial imports/exports are set forth in 10 CFR Part 110. NRC amended these regulations in 1995, to conform to the guidelines of the IAEA Code of Practice on the International Transboundary Movement of Radioactive Waste. They remain in force and are consistent with the guidelines of the Joint Convention. NRC amended Part 110 in 2005, to make the regulations consistent with the current version of the IAEA Code of Conduct on the Safety and Security of Radioactive Sources, as well as the Guidance on the Import and Export of Radioactive Sources, approved by the IAEA Board of Governors and endorsed by the General Conference in September 2004. These amendments, which became effective December 28, 2005, established specific licensing requirements for U.S. imports and exports of the materials in Part 110 Appendix P. The provisions pertaining to radioactive waste remain in force, and are consistent with the guidelines in the Joint Convention. A specific NRC license is required for imports and/or exports of radioactive materials meeting the definition of radioactive waste.

#### I.1.1 Regulatory Issues and Considerations

The United States began considering options to establish better domestic controls for exports and imports of radioactive wastes in the mid-to-late 1980s. There was some concern about the potential impacts of unnecessarily restricting transfers of radioactive materials which otherwise were not considered significant for nuclear weapons proliferation or as potentially endangering public health and safety if improperly handled. The process to develop and finalize U.S. regulations for the export and import of radioactive waste involved extensive review, consultation and revision.

The United States developed the rationale for and clearly defined what additional exports and imports of nuclear materials should be controlled as radioactive waste to

<sup>142</sup>Although not covered in this report, NRC is also responsible for imports and exports of nuclear production and utilization facilities and any equipment or components, which are especially designed or prepared for use in such facilities.

- A. Introduction
  - B. Policies & Practices
    - Article 32, paragraph 1
  - C. Scope of Application
    - Article 3.
  - D. Inventories & Lists
    - Article 32, paragraph 2
  - E. Legislative & Regulatory Systems
    - Article 18. Implementing Measures
    - Article 19. Legislative & Regulatory Framework
    - Article 20. Regulatory Body
  - F. General Safety Provisions
    - Article 21. Responsibility of License Holder
    - Article 22. Human & Financial Resources
    - Article 23. Quality Assurance
    - Article 24. Operational Radiation Protection
    - Article 25. Emergency Preparedness
    - Article 26. Decommissioning
  - G. Safety of Spent Fuel Management
    - Article 4. General Safety Requirements
    - Article 5. Existing Facilities
    - Article 6. Siting of Proposed Facilities
    - Article 7. Design & Construction of Facilities
    - Article 8. Facility Safety Assessment
    - Article 9. Facility Operation
    - Article 10. Spent Fuel Disposal
  - H. Safety of Radioactive Waste Management
    - Article 11. General Safety Requirements
    - Article 12. Existing Facilities & Past Practices
    - Article 13. Siting of Proposed Facilities
    - Article 14. Design & Construction of Facilities
    - Article 15. Facility Safety Assessment
    - Article 16. Facility Operation
    - Article 17. Institutional Measures After Closure
  - I. **Transboundary Movement**
    - **Article 27.**
  - J. Disused Sealed Sources
    - Article 28.
  - K. Planned Activities to Improve Safety
- Annexes

effectively protect public health and safety without unnecessarily curtailing international trade. It was understood a certain amount of flexibility was needed to preserve and facilitate continuation of useful practices. The most difficult part of establishing new regulations governing the U.S. export and import of radioactive wastes was developing appropriate definitions to distinguish materials needing to be controlled from those not needing special controls. NRC's approach was to establish two new categories of materials: radioactive waste and incidental radioactive material.

### **I.1.2 Radioactive Waste**

A specific license is required under 10 CFR Part 110, for non-DOE imports or exports of radioactive waste, defined as any waste containing or contaminated with source, special nuclear or byproduct materials. Such radioactive waste may also contain or be contaminated with hazardous waste.<sup>143</sup> Radioactive waste does not include radioactive material:

- Contained in a sealed source, or device containing a sealed source, being returned to any manufacturer qualified to receive and possess the sealed source or the device containing a sealed source;
- A contaminant on service equipment (including service tools) used in nuclear facilities, if the service equipment is being shipped for use in another nuclear facility and not for waste management purposes or disposal; or
- Generated or used in a United States Government waste research and development testing program under international arrangements.

As of December 28, 2005, a specific NRC export or import license is required if an individual shipment will exceed the amounts specified in Category 2 of Table 1 to 10 CFR Part 110 Appendix P. Although disused sources are usually authorized under a general export or import license, a specific export or import license could be required under 10 CFR Part 110 Appendix P. Because the Part 110 definition of radioactive waste was not changed, an application for a specific license to import a disused source under Appendix P would not be subject to the type of review required to process an application for a specific license to import radioactive waste.

### **I.1.3 Incidental Radioactive Material**

Under 10 CFR Part 110 "incidental radioactive material" is defined as radioactive material contained in or a contaminant of any non-radioactive material or component not decontaminated before recycling or recovery of the non-radioactive material or component occurs. Part 110 authorizes exports and imports of such material under a general license, which is effective without the issuance of licensing documents to a particular person. Those who plan to obtain a general license to export source, special nuclear or byproduct material as incidental radioactive material are required to submit certain information to NRC before the export takes place if the total weight of the shipment exceeds 100 kilograms. Those who plan to use a general license to import incidental radioactive material must be appropriately authorized to receive and possess it.

---

<sup>143</sup> Defined in Section 1004(5) of the Solid Waste Disposal Act, 42 U.S.C. 6903(5). EPA regulates imports and exports of hazardous waste.

#### **I.1.4 Spent Fuel**

NRC regulations adopted in 1995 did not specifically address exports of irradiated or spent nuclear fuel because other provisions governing exports of special nuclear and source material already covered it. However, the 1995 amendments established a requirement for a specific NRC license for imports of spent fuel if the shipment exceeds 100 kilograms. This requirement does not apply to DOE, however, because DOE has separate statutory authority to import nuclear material and equipment and is not subject to NRC import licensing.

### **I.2 Regulatory Requirements for Export or Import of Radioactive Waste**

A detailed comparison of NRC's regulatory regime<sup>144</sup> with the Radioactive Waste Transboundary Movement provisions of the Joint Convention is provided in the Second U.S. National Report, Annex I. After an applicant seeking a license to import or export radioactive waste has provided the required information, NRC forwards the application to the U.S. Department of State (DoS). DoS is responsible for coordinating review by interested U.S. Federal Government agencies and contacting the foreign government in the nation where the material originated or is destined to either provide notice or obtain consent in accordance with Joint Convention guidelines. DoS may also consult with foreign governments of transit nations if necessary to satisfy Joint Convention guidelines. For additional information regarding responsibility for transboundary movement through nations of transit, see Annex I, of the Second U.S. National Report.

It must be determined that the proposed transaction will not be inimical to the common defense and security of the United States and will not result in unreasonable risks to the public health and safety before an export or import license is issued. A brief description of the process for each is provided below since the reviews for exports and imports involve different considerations.

#### **I.2.1 Exports**

For proposed exports of radioactive waste, DoS asks the government of the recipient nation if it will accept such an import from the United States and requests confirmation the designated consignee is authorized to receive the radioactive waste. The DoS will ask the government to provide assurances the material will be maintained in accordance with terms and conditions of the agreement if the material is subject to a peaceful nuclear cooperation agreement between the United States and the recipient nation. The United States accepts responses and assurances received from the nation of destination as confirmation it has the administrative and technical capacity and regulatory structure to manage and dispose of the waste. NRC regulations do not require specific assessments and findings about the adequacy of the receiving nation's administrative and technical capacity and regulatory structure. NRC does not, however, contemplate any circumstances in which it would issue a license authorizing the export of radioactive waste to a nation without a regulated waste disposal program.

To issue a license for an export of radioactive waste, NRC must reach the conclusion the action will not be inimical to the common defense and security interests of the United

---

<sup>144</sup> Annex I-1 of the second U.S. National Report provides excerpts from Part 110 regulations governing the export or import of radioactive waste.

States. Several factors are considered including whether the government of the receiving nation has responded to a request from the DoS and consents to the proposed transaction. NRC will not act on an application until receiving a recommendation from interested U.S. Federal agencies including the recipient nation's consent. Additionally, export licensing criteria are specified at 10 CFR 110.42.

Prior to export of SNM, NRC requests either DoS or DOE to contact designated foreign government officials to provide assurances that the SNM will be subject to the terms of the applicable peaceful nuclear cooperation agreement in force between the United States and the importing nation. For exports of radioactive waste, NRC would ask DoS to contact the recipient nation in accordance with the guidelines in the Joint Convention.<sup>145</sup>

Nations importing enriched uranium from the United States for use as reactor fuel, whether it is in the form of fresh fuel or spent fuel, must obtain U.S. consent prior to retransferring it to a third party and for reprocessing, enrichment, or other alterations in form or content under the terms and conditions of U.S. peaceful nuclear cooperation agreements. Requests for U.S. approvals of such retransfers and alterations are submitted to and processed by DOE's National Nuclear Security Administration (NNSA), which coordinates U.S. interagency review of the proposed transaction. The United States is also consulted about the return of materials resulting from reprocessing if a nation obtains U.S. approval to transfer spent fuel to a third nation for reprocessing.

### **I.2.2 Imports**

For proposed imports of radioactive waste, DoS contacts the government of the exporting nation and seeks acknowledgement they are aware of the proposed transaction and any comments they might wish to provide. NRC has exclusive U.S. jurisdiction within the United States (the states and U.S. territories) for granting or denying specific licenses for non-DOE imports of radioactive waste. NRC, however, does recognize the authority of the host state officials and the relevant LLW compact commission to accept an import of LLW for disposal in the compact region. NRC consults with interested state officials and LLW compact commissions as part of the review of an application for a license to import LLW. NRC will not grant an import license for waste intended for disposal unless it is clear the waste will be accepted by a disposal facility, the host state, and the compact commission (where applicable). These are among the factors considered in determining the appropriateness of the facility agreeing to accept the waste for management or disposal.

### **I.3 Implementation Experience to Date**

NRC ensures that exports and non-DOE imports of nuclear materials facilities and equipment under the Agency's jurisdiction are licensed in accordance with applicable U.S. statutory and regulatory requirements, as well as U.S. Government commitments towards legally binding international treaties and multilateral and bilateral agreements. In addition, NRC and DOE continue to exercise global leadership by adhering to and promoting the adoption of international guidance such as the Code of Conduct on the Safety and Security of Radioactive Sources. Examples of specific accomplishments include:

---

<sup>145</sup> See <http://www.nrc.gov/reading-rm/doc-collections/cfr/part110/part110-0042.html>

- Refining criteria for approving exports of Category 1 and 2 radioactive sources;
- Participating in international regulatory meetings to strengthen controls on transfers of radioactive sources of concern without disrupting legitimate commerce;
- Maintaining close relationships with our hemispheric neighbors to continue refining export and import protocols, procedures and controls;
- Participating in meetings of the Nuclear Suppliers Group;<sup>146</sup> and
- Refining criteria for approving exports of Category 1 and 2 radioactive sources.<sup>147</sup>

Table I-1 provides the total number of licensing actions and Tables I-2 provides the number of specific licenses issued for import or export of Category 1 and 2 radioactive materials. Appendix P to 10 CFR Part 110 provides import and export threshold limits for specific radionuclides. This includes discrete sources of <sup>226</sup>Ra.

Year	2000	2001	2002	2003	2004	2005	2006	2007	Total
Byproducts	1	0	0	2	6	7	2	1	19
Components	13	19	5	7	15	10	11	12	92
Moderator Material	4	2	3	3	6	3	1	2	24
Reactors & Major Reactor Components	4	5	2	0	1	3	1	3	19
Special Nuclear Material	50	86	68	53	56	51	64	35	463
Source Material	10	17	2	14	11	4	5	6	69
Waste Exports	2	3	1	4	1	5	2	4	22
Waste Imports	3	4	0	2	2	3	3	6	23
Total	87	138	81	85	98	86	89	69	733

Source: *NRC International Activities Annual Report FY 2007*, Office of International Programs, October 2007 (<http://www.nrc.gov/about-nrc/ip/oip-annual-report-fy2007-final.pdf>)

Year	Combination License	Export License	Import License	Total
2005	15	0	0	15
2006	49	15	19	83
2007	37	9	8	54
<b>Total</b>	<b>101</b>	<b>24</b>	<b>27</b>	<b>152</b>

Source: NRC, Office of International Programs

Recently, a variety of parties have expressed interest in certain applications received by NRC for specific licenses to import radioactive waste. In addition, the number of inquiries from external parties about incidental radioactive material has also increased.

<sup>146</sup> The Nuclear Suppliers Group is a group of nuclear supplier countries which seeks to contribute to the non-proliferation of nuclear weapons through the adherence to Guidelines for nuclear exports and nuclear related exports. See <http://www.nuclearsuppliersgroup.org/>

<sup>147</sup> The IAEA international nuclear and radiological event scale (INES) defines the categories of radioactive sources in <http://www.iaea.org/Publications/Factsheets/English/ines.pdf>

NRC is currently considering updating Part 110 regulations, which could result in changes to the export/import licensing requirements for radioactive waste.

#### **I.4 Security Programs**

DOE's NNSA is working to strengthen the capability of nations to deter, detect, and interdict illicit trafficking in nuclear and other radioactive materials across international borders and through the global maritime shipping system. The NNSA works with partner nations to equip border crossings, airports and seaports with radiation detection equipment, provides training in the use of the systems, and provides initial system support until the host government assumes operational responsibility.

The Second Line of Defense Core Program installs radiation detection equipment at borders, airports, and strategic feeder ports in Russia, the former Soviet Union states, and other countries. Approximately 450 sites may potentially receive detection equipment installations. Under a joint program between the United States and Russia, a total of 117 sites in Russia were equipped between 1998 and September 2007, and all 350 Russia's border crossings should be equipped by the end of 2011. Radiation detection systems installation and training are proceeding in 12 other nations.

Another important project, the Megaports Initiative, provides radiation detection equipment and training programs at key international seaports to screen cargo containers for nuclear and other radioactive material. The United States works with other nations to deter, detect, and interdict illegal shipments. Detection equipment is planned at 75 ports worldwide. Since 2003, the Megaports Initiative is fully operational in 12 countries and in various stages of implementation at 17 other locations.

## J. DISUSED SEALED SOURCES

### J.1 General Safety for Sealed Sources

Radiation safety programs for use of byproduct material as a sealed source or device are based on robust containment of radioactive material. Sealed sources or devices are designed to withstand stresses imposed by the environment in which they are possessed and used. Regulations in 10 CFR Parts 30, 31, 32, 34, 35, 36, and 39 provide requirements for both vendors and users of sealed sources and devices. Agreement States issue compatible regulations for the control of sealed sources and devices within their borders.

Certain regulations require radioactive sources in products used under a specific license issued in accordance with 10 CFR Parts 30-39 to be registered with NRC or an Agreement State. In addition, for products using byproduct material in the form of a sealed source or in a device that contains the sealed source, 10 CFR 30.32(g) requires a license applicant to either make reference to a registered sealed source or device or provide the information necessary to perform a safety evaluation of the sealed source or device. 10 CFR 32.210 outlines NRC's safety evaluation and registration criteria; furthermore, the regulations clarify the regulatory responsibility of those who hold product registration certificates. This practice has been used since the 1950s and allows regulatory agencies to ensure designs meet all regulatory requirements, maintain their integrity under both normal use and credible accident conditions. This process allows applicants and license reviewers to reference the evaluation when licensing the product for use or distribution without having to perform a complete evaluation of the product for each licensing action. Regulations in 10 CFR Parts 34, 35, 36, and 39, provide additional requirements for specific types of sources and devices. Regulations in 10 CFR Parts 30, 31, and 32 also allow for use of equipment requiring registration but not requiring a license for use, and for sources and devices requiring neither registration nor licensing if they meet certain requirements.

NRC and the Agreement States perform safety evaluations of the ability of sealed sources and devices to contain licensed material for use under the conditions requested. These evaluations are summarized in registrations. The registrations are maintained by NRC in the National Sealed Source and Device Registry. The Registry is currently unavailable for general public access. Information on the regulatory process for evaluating and licensing sealed sources and devices is available to the public through NRC's website.<sup>148</sup> Agreement States also provide information on their radiation safety

- A. Introduction
- B. Policies & Practices
  - Article 32, paragraph 1
- C. Scope of Application
  - Article 3.
- D. Inventories & Lists
  - Article 32, paragraph 2
- E. Legislative & Regulatory Systems
  - Article 18. Implementing Measures
  - Article 19. Legislative & Regulatory Framework
  - Article 20. Regulatory Body
- F. General Safety Provisions
  - Article 21. Responsibility of License Holder
  - Article 22. Human & Financial Resources
  - Article 23. Quality Assurance
  - Article 24. Operational Radiation Protection
  - Article 25. Emergency Preparedness
  - Article 26. Decommissioning
- G. Safety of Spent Fuel Management
  - Article 4. General Safety Requirements
  - Article 5. Existing Facilities
  - Article 6. Siting of Proposed Facilities
  - Article 7. Design & Construction of Facilities
  - Article 8. Facility Safety Assessment
  - Article 9. Facility Operation
  - Article 10. Spent Fuel Disposal
- H. Safety of Radioactive Waste Management
  - Article 11. General Safety Requirements
  - Article 12. Existing Facilities & Past Practices
  - Article 13. Siting of Proposed Facilities
  - Article 14. Design & Construction of Facilities
  - Article 15. Facility Safety Assessment
  - Article 16. Facility Operation
  - Article 17. Institutional Measures After Closure
- I. Transboundary Movement
  - Article 27.
- J. Disused Sealed Sources**
  - Article 28.
- K. Planned Activities to Improve Safety Annexes

<sup>148</sup> See <http://www.nrc.gov/materials/miau/sealed-source.html>

evaluations to NRC for the registry. A vendor only needs to provide detailed information about its sealed source or device to the regulatory agency that has jurisdiction. NRC estimates there are approximately 2,000,000 of these devices in existence.

As part of the IAEA implementation of the “Action Plan for the Safety of Radiation Sources and Security of Radioactive Material,” in 2005 the IAEA developed the International Catalogue of Sealed Sources and Devices. The key objectives of this activity are to provide information to Member States to assist in the identification of disused or uncontrolled radioactive sources and devices government agencies and private entities may encounter and to provide readily available hazard information to assist and inform emergency response personnel. The Catalogue was initially populated with information provided by NRC from its National Sealed Source and Device Registry. The IAEA is continuing to populate the Catalogue from sealed source and device information from other Member States and periodic updates from NRC and DOE.

Licensees possessing, using, packaging, handling, transferring and disposing licensed material are required to comply with the general occupational and public radiological protection regulations, listed in Table E-2. This includes licensing, financial assurance and record keeping for decommissioning, and expiration and termination of licenses and decommissioning.

## **J.2 Reentry of Disused Sealed Sources from Abroad**

NRC published regulations on November 8, 2006 (Federal Register, 71 FR 65685) to implement the National Source Tracking System (NSTS). The purpose is to enhance controls for certain radioactive materials considered to be of the greatest concern from a safety and security standpoint. The NSTS involves other Federal and State agencies, and international partners and requires NRC licensees to report all Category 1 and 2 sealed sources through the NSTS by January 2009. The NSTS will require licensees to report the manufacture, transfer, receipt, disassembly, and disposal of nationally tracked sources. The NSTS is an important component of the NRC’s effort to enhance the control of radioactive material and prevent its use by the nation’s adversaries. There are approximately 54,000 of these sources in use.

U.S. regulations do not bar the return of disused sealed sources (see Section I.1.2). The United States, recognizing the need to address the threat of radiological terrorism, has led international efforts to strengthen controls over international transfers of radioactive sources and materials, including those sources that could be used in a radioactive dispersal device or “dirty bomb.” U.S. efforts have yielded significant progress, including the revision of the non-legally binding International Atomic Energy Agency (IAEA) Code of Conduct on the Safety and Security of Radioactive Sources (Code). G-8 Leaders<sup>149</sup> agreed at the Sea Island Summit in June 2004 to work toward effective import/export controls for radioactive sources. The IAEA Board of Governors, on September 14, 2004,

---

<sup>149</sup> The Group of Eight (G8), also known as Group of Seven and Russia, is an international forum for the governments of Canada, France, Germany, Italy, Japan, Russia, the United Kingdom and the United States. Together, these countries represent about 65% of the world economy and the majority of global military power (7 of the top 8 positions for military expenditure, and almost all of the world’s active nuclear weapons. The G8 can refer to the member states or to the annual summit meeting of the G8 heads of government.



approved the import/export guidance<sup>150</sup> for radioactive sources, which had been finalized in July 2004, by an IAEA expert group representing 41 Member States.

NRC amended domestic licensing requirements to be consistent with the revised Code and international import/export guidance for imports and exports of IAEA Category 1 and 2 radioactive sources and material. Beginning on January 1, 2006, transfers of these radioactive sources into or out of the United States must be approved by NRC in a specific import or export license as noted in Section I-2. DOE is also developing guidance for sealed sources within its authority and control, consistent with the IAEA Code of Conduct and the Import/Export guidance. The United States continues to promote greater harmonization for strengthening controls over international transfers of radioactive sources.<sup>151</sup>

### **J.3 Disposition of Sealed Sources**

Sealed source retrieval efforts have recently become a priority to reduce the risk from both accidental and intentional dispersal of radioactive materials. Retrieved sources are managed in accordance with the objectives of the Joint Convention found in Article 1. Disused sources are not declared waste until they are accepted for disposal at commercial or governmental facilities. The contribution to total volume disposed is negligible because the volume of disposed disused sealed sources is small in comparison to the larger volumes of commercial and government waste.

Licensees possessing GTCC LLW sources are responsible for properly storing the sources in accordance with NRC or Agreement State regulatory and/or license requirements until a disposal facility or alternative disposition path (such as recycling) is available. These sources must be stored at the owners' facilities or at commercial facilities in accordance with NRC or Agreement State licensing requirements (10 CFR Parts 30, 32, 33, 34, 35, 36, and 39). These regulations require licensees to secure the material in accordance with regulatory requirements to prevent unauthorized removal or access licensed materials stored in controlled or unrestricted areas.

The United States has several programs to recover and manage orphan sealed sources. The Conference of Radiation Control Program Directors (a non-governmental organization) administers the National Orphan Radioactive Material Disposition Program<sup>152</sup> to provide technical assistance and funding to disposition orphan sealed sources. DOE's NNSA Offsite Source Recovery Project (OSRP),<sup>153</sup> part of the U.S. Radiological Threat Reduction Program, recovers sealed sources in the possession of NRC and Agreement States licensees that present threats to public health and safety or national security. In addition, EPA has the authority and capability to recover orphan sources.

---

<sup>150</sup> This guidance was endorsed by the IAEA General Conference on September 24, 2004 (see GC(48)/RES/10), and published by the IAEA on March 30, 2005 (IAEA/CODEOC/IMP-EXP/2005). Certain imports and exports for defense purposes are excluded from the IAEA Code of Conduct and the Import/Export guidance.

<sup>151</sup> Key objectives of the G-8 Evian, Sea Island and Glen Eagle Summits.

<sup>152</sup> See <http://crcpd.org/orphans.asp>

<sup>153</sup> See <http://osrp.lanl.gov/>

#### **J.4 U.S. Radiological Threat Reduction Program**

The U.S. Radiological Threat Reduction program identifies, recovers, and, as appropriate, disposes high-risk radioactive sealed sources and other radioactive materials that present public health and safety or national security threats and are in the possession of NRC and Agreement State licensees in the United States. DOE's OSRP collects these sealed sources and stores them. Sources meeting DOE or commercial disposal facility acceptance criteria are disposed of. The project also recovers U.S.-origin disused sealed sources in other nations. Source recovery activities began in 1999 and as of February 2008, over 6,600 sources (containing 6 PBq of radionuclides) were recovered from over 650 sites in the United States and around the world.

Americium or plutonium sources, recovered by the U.S. Radiological Threat Reduction Program, potentially may be disposed as defense TRU waste at the Waste Isolation Pilot Plant in New Mexico if they meet the waste acceptance criteria for the facility. Some <sup>137</sup>Cs, <sup>90</sup>Sr, and <sup>60</sup>Co sources meet disposal acceptance criteria at commercial low-level radioactive waste disposal facilities. Recovered sealed sources not meeting the waste acceptance requirements for existing disposal facilities are stored pending a future disposition path.

#### **J.5 Illicit Trafficking and Nuclear Terrorism**

The United States actively supports a wide range of international, multilateral and bilateral initiatives to minimize the potential for unauthorized acquisition, possession, use, transfer and/or disposal of radioactive materials of concern to the global community. The United States contributes to programs, such as the Global Initiative to Combat Nuclear Terrorism, and urges all nations to adhere to legally binding commitments and follow non-binding guidance to enhance the safe and secure use of radioactive materials including sealed sources and devices covered by the IAEA Code of Conduct on the Safety and Security of Radioactive Sources.

The United States continues to work with numerous partners internationally, multilaterally and bilaterally to further develop and/or strengthen national as well as regional detection and response capabilities to deter illicit trafficking and unauthorized transfers. The United States also supports a wide range of collaborative efforts to increase the effectiveness of information sharing networks including among border protection officials, so that responsible authorities are better able to recognize the circumstances, patterns and trends associated with such activities. In this regard, the IAEA's Illicit Trafficking Database (ITDB), which was set up in 1995 to collect information on illicit trafficking and other unauthorized activities involving nuclear and radioactive material, is one of several tools that augments and supports the safety and security objectives of the IAEA Code of Conduct.

The United States recently formed an interagency Radiation Source Protection and Security Task Force<sup>154</sup> to evaluate and make recommendations to Congress and the President on the protection and security of radiation sources, including orphan sources. The Task Force completed its initial report August 15, 2006. Although the conclusions

---

<sup>154</sup> See [http://hps.org/govtrelations/documents/nrc\\_source\\_taskforce\\_execsummary.pdf](http://hps.org/govtrelations/documents/nrc_source_taskforce_execsummary.pdf)

and outcomes were focused on system and infrastructure recommendations, such as cooperating in the global effort to follow the guidance in IAEA's Code of Conduct, there was some acknowledgement of the activities associated with detection of transboundary shipments and traffic.

As an example of an outcome of the task force, NRC has worked with DHS Customs and Border Protection, and a program is in place to verify the legitimacy of shipments of licensed radioactive material entering the United States through established ports of entry. Specific information regarding NRC's cooperation with U.S. Customs can be accessed from NRC's webpage on NRC's Source Data Team and U.S. Customs.<sup>155</sup>

The responsibility for developing a global illicit source detection system has been designated to a new office within the U.S. Department of Homeland Security (DHS); this entity is known as the Domestic Nuclear Detection Office (DNDO), which was established to develop, acquire, and support the deployment of a domestic system to detect and report attempts to import or transport a nuclear device or fissile or radiological material intended for illicit use. These efforts will increase the ability of law enforcement officials to detect licensed material in shipments and provide a means to intercept lost or stolen domestic sources or illegal shipments along major highway routes. The domestic system being deployed consists of handheld and portal radiation monitors purchased by state and local entities (typically, law enforcement and fire brigades). DNDO is developing and will provide training for the state and local entities.

---

<sup>155</sup> See <http://www.nrc.gov/security/byproduct/export-import/source-data-team.html>

This page intentionally left blank

## K. PLANNED ACTIVITIES TO IMPROVE SAFETY

This report has described many existing and ongoing U.S. activities ensuring the safe management of spent fuel and radioactive waste. The United States is already in compliance with the conditions set forth in the Joint Convention. There are, however, several key areas important to safety continuing to receive much attention.

### K.1 Spent Fuel and High-Level Waste Storage and Disposal

Developing disposal capability for spent fuel and high-level waste (HLW) remains a key activity for long-term safety of spent fuel and HLW management. DOE submitted a license application to NRC on June 3, 2008 for authorization to construct the proposed geologic repository at Yucca Mountain, Nevada. On September 8, 2008, NRC docketed the Yucca Mountain license application, which triggered a three-year deadline, with a possible one-year extension, for NRC to decide whether or not to grant a construction authorization to DOE. Following completion of construction, DOE will then apply to NRC for a license amendment to allow receipt and possession of waste.

Commercial reactor sites will continue to store spent fuel in reactor pools and dry casks using NRC approved dry cask designs. Even when a geological repository becomes available, using pools and ISFSIs for interim storage of spent fuel in the United States will continue.

### K.2 Commercial Low-Level Waste Disposal

There remains uncertainty in the availability of commercial disposal for Class B and C LLW because the Atlantic Compact (South Carolina, New Jersey and Connecticut) eliminated access to the Barnwell, South Carolina site for generators outside the compact as of July 1, 2008. Efforts by regional compacts to site new disposal facilities have been unsuccessful. Congress and government agencies continue to monitor the availability of commercial LLW disposal facilities to meet future needs, although opposition to new disposal sites for LLW waste makes it difficult to site new facilities. NRC conducted a strategic assessment<sup>156</sup> of the commercial LLW program to evaluate regulatory actions to ensure a stable, reliable and adaptable regulatory framework for management of LLW. NRC identified and evaluated twenty potential activities that could be undertaken to improve the LLW regulatory framework. Among the activities ranked as high priority are (1) updating NRC's guidance on extended storage of LLW for materials and fuel cycle licensees,<sup>157</sup> (2) developing and implementing guidance on alternative disposal requests, (3) determining if disposal of large quantities of depleted uranium from enrichment plants warrant change in uranium waste classification, and (4) updating a

A.	Introduction
B.	Policies & Practices <ul style="list-style-type: none"><li>▪ Article 32, paragraph 1</li></ul>
C.	Scope of Application <ul style="list-style-type: none"><li>▪ Article 3.</li></ul>
D.	Inventories & Lists <ul style="list-style-type: none"><li>▪ Article 32, paragraph 2</li></ul>
E.	Legislative & Regulatory Systems <ul style="list-style-type: none"><li>▪ Article 18. Implementing Measures</li><li>▪ Article 19. Legislative &amp; Regulatory Framework</li><li>▪ Article 20. Regulatory Body</li></ul>
F.	General Safety Provisions <ul style="list-style-type: none"><li>▪ Article 21. Responsibility of License Holder</li><li>▪ Article 22. Human &amp; Financial Resources</li><li>▪ Article 23. Quality Assurance</li><li>▪ Article 24. Operational Radiation Protection</li><li>▪ Article 25. Emergency Preparedness</li><li>▪ Article 26. Decommissioning</li></ul>
G.	Safety of Spent Fuel Management <ul style="list-style-type: none"><li>▪ Article 4. General Safety Requirements</li><li>▪ Article 5. Existing Facilities</li><li>▪ Article 6. Siting of Proposed Facilities</li><li>▪ Article 7. Design &amp; Construction of Facilities</li><li>▪ Article 8. Facility Safety Assessment</li><li>▪ Article 9. Facility Operation</li><li>▪ Article 10. Spent Fuel Disposal</li></ul>
H.	Safety of Radioactive Waste Management <ul style="list-style-type: none"><li>▪ Article 11. General Safety Requirements</li><li>▪ Article 12. Existing Facilities &amp; Past Practices</li><li>▪ Article 13. Siting of Proposed Facilities</li><li>▪ Article 14. Design &amp; Construction of Facilities</li><li>▪ Article 15. Facility Safety Assessment</li><li>▪ Article 16. Facility Operation</li><li>▪ Article 17. Institutional Measures After Closure</li></ul>
I.	Transboundary Movement <ul style="list-style-type: none"><li>▪ Article 27.</li></ul>
J.	Disused Sealed Sources <ul style="list-style-type: none"><li>▪ Article 28.</li></ul>
K.	<b>Planned Activities to Improve Safety</b>
	Annexes

<sup>156</sup> See <http://www.nrc.gov/reading-rm/doc-collections/commission/secys/2007/secy2007-0180/2007-0180scy.pdf>

<sup>157</sup> The updated guidance, NRC Regulatory Issue Summary 2008-12, May 9, 2008, Considerations for Extended Interim Storage of Low-Level Radioactive Waste by Fuel Cycle and Materials Licensees. ML073330600.

guidance document (Branch Technical Position) on LLW concentration averaging and encapsulation. In this light, the ACNW&M analyzed RCRA Subtitle C hazardous waste sites as potential options for disposal of certain types of LLW.<sup>158</sup> This effort addresses related reports by the National Academy of Sciences and the U.S. Government Accountability Office.

The State of Texas received an application from Waste Control Specialists (WCS) in 2004 for a new LLW disposal facility, near Andrews, Texas, for the Texas Compact (Texas and Vermont)<sup>159</sup>. In August 2008, the Texas Commission on Environmental Quality (TCEQ) issued a draft license for public comment. If approved, the license will authorize WCS to receive, possess, use, store, dispose and transfer LLW for near-surface disposal. Such waste is limited to “compact waste” and “Federal facility waste” in separate and distinct disposal areas on the site. Compact waste includes LLW generated in Texas, Vermont or other waste approved for importation to Texas. Federal facility waste includes LLW that is the responsibility of the Federal government under the LLRWPA, as amended. GTCC LLW is specifically excluded from the definition of “Federal facility waste.”

### **K.3 Disused Sealed Sources and Greater-than-Class C LLW Disposal**

The U.S. Government has an aggressive program to collect thousands of disused sealed sources that present public health and safety and national security threats from the commercial sector for safe storage and eventual disposal as described in Section J. This activity decreases the likelihood for accidents or misuse of this material across the nation. Many of these sources are GTCC LLW while in the possession of licensees (see Table B-1). GTCC LLW is being stored at nuclear power plants and other facilities until an adequate disposition policy is determined in accordance with the LLRWPA. The LLRWPA directs that GTCC LLW generated by NRC-licensed activities be disposed of in an NRC-licensed facility. The U.S. Government is analyzing the environmental impacts of various options for GTCC LLW disposal.

New requirements in EPA05 related to management and disposal of disused sealed sources and GTCC LLW are being evaluated by Federal agencies. For example, NRC implemented regulatory changes strengthening domestic licensing requirements for the import and export of high-risk radioactive sources and materials. These revisions to 10 CFR Part 110 bring U.S. import/export controls in line with the revised IAEA Code of Conduct on the Safety and Security of Radioactive Sources and international import/export guidance.

### **K.4 Accelerated Return of Weapons-Usable Uranium from Other Countries to the United States and Russian Federation**

The United States in partnership with the IAEA, Russian Federation, and other nations established the Global Threat Reduction Initiative (GTRI) in May 2004 to remove and/or secure high-risk nuclear and radiological materials and equipment around the world posing a threat to the United States and to the international community. This initiative, based on a strategy where a more secure world is a safer world, is designed to comprehensively address all vulnerable nuclear and radiological materials and secure and/or remove these materials and equipment as quickly as possible.

---

<sup>158</sup> Available from the NRC web site at

[http://adamswebsearch2.nrc.gov/idmws/doccontent.dll?library=PU\\_ADAMS^PBNTAD01&ID=081260045](http://adamswebsearch2.nrc.gov/idmws/doccontent.dll?library=PU_ADAMS^PBNTAD01&ID=081260045).

<sup>159</sup> The selection process allowed any interested commercial firm to submit a license application for a site meeting Texas regulatory criteria. Texas law applies to site selection. As an Agreement State, Texas regulatory requirements must be compatible with those of NRC, i.e., 10 CFR Part 61. For more information, see [http://www.tceq.state.tx.us/permitting/waste\\_permits/rad\\_waste/wcs\\_license\\_app.html](http://www.tceq.state.tx.us/permitting/waste_permits/rad_waste/wcs_license_app.html)

Eliminating the use of HEU in civil applications and securing, returning, or recovering the high-risk nuclear material is an important part of the GTRI program. As of February 2008 the United States through the GTRI:

- Helped secure over 565 radiological sites around the world, containing over 314 PBq (8.5 million Ci) of radioactivity;
- Provided assistance for return of approximately 590 kilograms of Russian-origin HEU fresh (unused) or spent fuel to Russia from Serbia, Romania, Bulgaria, Libya, Uzbekistan, Poland, Germany, Latvia, the Czech Republic, and Vietnam;
- Removed 140 kilograms of US-origin HEU fresh fuel from Canada, Belgium, the Netherlands, and Italy;
- Accepted the return of 1,140 kilograms of US-origin HEU spent fuel from around the world (U.S. origin HEU research reactor spent fuel acceptance will continue until 2019, with 2016 the deadline for irradiation);
- Supported conversion of 51 research reactors around the world from HEU to LEU and shutdown of 4 civilian HEU research reactors;
- Down-blended over 92 metric tons of surplus U.S. HEU into LEU for use in civilian nuclear reactors; and
- Converted nearly 10 metric tons of surplus Russian HEU into LEU for use in civilian nuclear reactors.

## **K.5 Global Nuclear Energy Partnership**

The Global Nuclear Energy Partnership (GNEP) was announced by DOE in February, 2006. The DOE GNEP Program is intended to support a safe, secure, sustainable expansion of nuclear energy, both domestically and internationally. The domestic element of the program, under the Advanced Fuel Cycle Initiative (AFCI), would promote technologies that support economic, sustained production of nuclear-generated electricity, while improving nuclear safeguards and reducing the impacts associated with spent fuel disposal. Under the AFCI/GNEP Program, the U.S. nuclear energy fuel cycle would change from an open (or once-through) fuel cycle—in which nuclear fuel is used in a power plant one time and the resulting spent fuel is stored for eventual disposal in a geologic repository—to a closed fuel cycle in which spent fuel would be recycled to recover energy-bearing components for use in new nuclear fuel. DOE is preparing a draft Programmatic Environmental Impact Statement that will analyze the environmental impacts of various programmatic alternatives for changing the U.S. nuclear fuel cycle. A geological repository is needed regardless of the fuel cycle scenario.

The GNEP Program also has an international component pursuant to which the U.S. would cooperate with other fuel cycle nations (i.e., those already recycling spent fuel) to develop and deploy advanced nuclear recycling and reactor technologies in those countries in order to move away from producing separated pure plutonium. Further, GNEP seeks to establish international frameworks to enhance reliable, cost-effective fuel services and supplies to the world market, providing options for generating nuclear energy and fostering development while reducing the risk of nuclear proliferation by creating a viable alternative to acquisition of sensitive fuel cycle technologies. Under the GNEP reliable fuel services concept, supplier nations would provide both “front-end” services (i.e., assuring reliable fuel supplies to user nations) and “back-end” services (i.e., the management of spent fuel, including arrangements for recycling). To date, 25 member countries have signed the GNEP Statement of Principles.<sup>160</sup>

---

<sup>160</sup> For more information regarding the GNEP Program, see <http://www.gnep.energy.gov>.

This page intentionally left blank



## **ANNEXES**



**Annex D-1 Spent Fuel Management Facilities**

State	Installation	Facility	Function	Licensee	Regulator	SF <sup>161</sup> Source	Inventory	Estimated Activity (Bq)
<b>Government Facilities (Inventory as of December 2006)</b>								
Colorado	U.S. Geological Survey (Denver)	Research/Test Reactor	Wet Storage	U.S. Geological Survey	NRC	2	0.04 MTHM	5.37E+14
Idaho	Idaho National Lab	CPP-666	Wet Storage	DOE	DOE	1, 2	8.55 MTHM	4.11E+17
		Multiple INL facilities	Dry Storage	DOE	DOE/NRC	1, 2	270.47 MTHM	1.86E+18
Illinois	Argonne National Lab	ANL SF Storage	Dry Storage	DOE	DOE	1, 2	0.12 MTHM	4.11E+15
Maryland	National Institute of Standards and Technology (Gaithersburg)	Research/Test Reactor	Wet Storage	National Institute of Standards and Technology	NRC	2	0.02 MTHM	9.47E+16
	Armed Forces Radiobiology Research Institute (Bethesda)	Research/Test Reactor	Wet Storage	Armed Forces Radiobiology Research Institute	NRC	1	0.02 MTHM	3.02E+14
Nevada	Yucca Mountain Site	Proposed Geologic Repository	SF and HLW Disposal	DOE	NRC	1, 2	0	0
New Mexico	Sandia National Lab	Multiple SNL Facilities	Dry Storage	DOE	DOE	1, 2	0.29 MTHM	7.40E+10
Rhode Island	Rhode Island Atomic Energy Commission (Narragansett)	Research/Test Reactor	Wet Storage	Rhode Island Atomic Energy Commission	NRC	2	0.02 MTHM	3.96E+14
South Carolina	Savannah River Site	L-Basin	Wet Storage	DOE	DOE	1, 2	29.41 MTHM	1.10E+18
	Savannah River Site	L-Basin	Dry Storage	DOE	DOE	2	0.01 MTHM	
Tennessee	Oak Ridge Reservation	Oak Ridge Reservation	Wet Storage	DOE	DOE	2	0.48 MTHM	4.44E+17
Washington	Hanford Site	Multiple Hanford facilities	Dry Storage	DOE	DOE	1, 2	2128.95 MTHM	1.79E+18
<b>University Research Facilities (Inventory as of December 2006)</b>								
Arizona	University of Arizona (Tucson)	Research Reactor	Wet Storage	University of Arizona	NRC	2	18.27 kgU	3.96E+14
California	University of California (Irvine)	Research Reactor	Wet Storage	University of California	NRC	2	21.42KgU	9.99E+13
	University of California <sup>162</sup> (Davis)	Research Reactor	Wet Storage	University of California	NRC	2	72.31 kgU	9.95E+14
Florida	University of Florida (Gainesville)	Research Reactor	Wet Storage	University of Florida	NRC	2	5.00 kgU	3.17E+13

<sup>161</sup>SF Sources: 1-Defense applications; 2-Commercial NPPs and Test/Research Reactors.

<sup>162</sup>Formerly McClellan AFB (Sacramento)

**Annex D-1 Spent Fuel Management Facilities**

State	Installation	Facility	Function	Licensee	Regulator	SF <sup>161</sup> Source	Inventory	Estimated Activity (Bq)
Indiana	Purdue University (West Lafayette)	Research Reactor	Wet Storage	Purdue University	NRC	2	2.22 kgU	2.47E+14
Kansas	Kansas State University (Manhattan)	Research Reactor	Wet Storage	Kansas State University	NRC	2	21.08 kgU	7.70E+14
Maryland	University of Maryland (College Park)	Research Reactor	Wet Storage	University of Maryland	NRC	2	16.35 kgU	4.92E+14
Massachusetts	University of Lowell (Lowell)	Research Reactor	Wet Storage	University of Lowell	NRC	2	14.63 kgU	3.46E+14
	Massachusetts Institute of Technology (Cambridge)	Research Reactor	Wet Storage	Massachusetts Institute of Technology	NRC	2	19.85 kgU	3.77E+16
	Worcester Polytechnic Institute (Worcester)	Research Reactor	Wet Storage	Worcester Polytechnic Institute	NRC	2	22.75 kgU	1.41E+13
Missouri	University of Missouri (Columbia)	Research Reactor	Wet Storage	University of Missouri	NRC	2	35.44 kgU	6.18E+16
	University of Missouri (Rolla)	Research Reactor	Wet Storage	University of Missouri	NRC	2	26.46 kgU	3.29E+15
North Carolina	North Carolina State University (Raleigh)	Research Reactor	Wet Storage	North Carolina State University	NRC	2	315.4 kgU	6.22E+14
Ohio	Ohio State University (Columbus)	Research Reactor	Wet Storage	Ohio State University	NRC	2	26.15 kgU	3.16E+14
Oregon	Oregon State University (Corvallis)	Research Reactor	Wet Storage	Oregon State University	NRC	2	17.42 kgU	8.55E+14
	Reed College (Portland)	Research Reactor	Wet Storage	Reed College	NRC	2	12.59 kgU	4.00E+13
Pennsylvania	Pennsylvania State University (University Park)	Research Reactor	Wet Storage	Pennsylvania State University	NRC	2	37.57 kgU	1.88E+15
Texas	Texas A&M University (College Station)	Research Reactor (2)	Wet Storage	Texas A&M University	NRC	2	29.48 kgU	1.60E+15
	University of Texas (Austin)	Research Reactor	Wet Storage	University of Texas	NRC	2	35.17 kgU	2.68E+14
Utah	University of Utah (Salt Lake City)	Research Reactor	Wet Storage	University of Utah	NRC	2	26.82 kgU	1.22E+15
Washington	Washington State University (Pullman)	Research Reactor	Wet Storage	Washington State University	NRC	2	36.72 kgU	3.01E+15
Wisconsin	University of Wisconsin (Madison)	Research Reactor	Wet Storage	University of Wisconsin	NRC	2	39.29 kgU	3.07E+15

**Annex D-1 Spent Fuel Management Facilities**

State	Installation	Facility	Function	Licensee	Regulator	SF <sup>161</sup> Source	Inventory	Estimated Activity (Bq)
<b>Commercial Facilities (Inventory as of December 31, 2007, per DOE projections)<sup>163</sup></b>								
Alabama	Browns Ferry	ISFSI	Dry Storage	Tennessee Valley Authority	NRC	2	50 MTHM	
	Browns Ferry 1, 2 & 3	Nuclear Power Plant Pools	Wet Storage				1,450 MTHM	
	Farley	ISFSI	Dry Storage	Southern Nuclear Operating Company	NRC	2	80 MTHM	
	Farley 1 & 2	Nuclear Power Plant Pools	Wet Storage				1,000 MTHM	
Arkansas	Arkansas Nuclear One	ISFSI	Dry Storage	Entergy Nuclear Operations	NRC	2	580 MTHM	
	Arkansas Nuclear 1 & 2	Nuclear Power Plant Pools	Wet Storage				530 MTHM	
Arizona	Palo Verde	ISFSI	Dry Storage	Arizona Public Service Company	NRC	2	550 MTHM	
	Palo Verde 1, 2 & 3	Nuclear Power Plant Pools	Wet Storage				1,070 MTHM	
California	Aerotest Research (San Ramon)	Research/Test Reactor	Wet Storage	Aerotest Research	NRC	2	17.43 kgU	3.54E+15
	Diablo Canyon 1 & 2	Nuclear Power Plant Pools	Wet Storage	Pacific Gas & Electric Company	NRC	2	960 MTHM	
	General Atomics (San Diego)	Research/Test Reactor (2)	Wet Storage	General Atomics	NRC		53.47 kgU	3.44E+15
	General Electric (Pleasanton)	Research/Test Reactor	Wet Storage	General Electric	NRC	2	3.86 kgU	3.85E+12
	Humboldt Bay	ISFSI	Dry Storage	Pacific Gas & Electric Company	NRC	2	0 MTHM	
	Humboldt Bay (shutdown)	Nuclear Power Plant Pool	Wet Storage		NRC	2	30 MTHM	
	Rancho Seco (shutdown)	ISFSI	Dry Storage	Sacramento Municipal Utility District	NRC	2	230 MTHM	
	San Onofre	ISFSI	Dry Storage	Southern California Edison Company	NRC	2	220 MTHM	
San Onofre 1 (shutdown), San Onofre 2 & 3	Nuclear Power Plant Pools	Wet Storage	1,080 MTHM					
Colorado	Fort St. Vrain	ISFSI (Storage Well)	Dry Storage	DOE	NRC	2	20 MTHM	1.07E+17
Connecticut	Haddam Neck (shutdown)	ISFSI	Dry Storage	Connecticut Yankee Atomic Power Company	NRC	2	410 MTHM	
	Millstone	ISFSI	Dry Storage	Dominion Generation	NRC	2	100 MTHM	

<sup>163</sup> These numbers are estimates. The most recently collected RW-859 Nuclear Fuel Data survey included data to December 31, 2002. Updates since then are based on DOE projections and publicly available information.

**Annex D-1 Spent Fuel Management Facilities**

State	Installation	Facility	Function	Licensee	Regulator	SF <sup>161</sup> Source	Inventory	Estimated Activity (Bq)
	Millstone 1 (shutdown), Millstone 2 & 3	Nuclear Power Plant Pools	Wet Storage				1,310 MTHM	
Florida	Crystal River 3	Nuclear Power Plant Pool	Wet Storage	Progress Energy	NRC	2	500 MTHM	
	St. Lucie 1 & 2	Nuclear Power Plant Pools	Wet Storage	Florida Power & Light Company	NRC	2	1,100 MTHM	
	Turkey Point 3 & 4	Nuclear Power Plant Pools	Wet Storage	Florida Power & Light Company	NRC	2	1,020 MTHM	
Georgia	Hatch	ISFSI	Dry Storage	Southern Nuclear Operating Company	NRC	2	410 MTHM	
	Hatch 1 & 2	Nuclear Power Plant Pools	Wet Storage	Southern Nuclear Operating Company	NRC	2	840 MTHM	
	Vogtle 1 & 2	Nuclear Power Plant Pools	Wet Storage	Southern Nuclear Operating Company	NRC	2	930 MTHM	
Illinois	Braidwood 1 & 2	Nuclear Power Plant Pool	Wet Storage	Exelon Generation Company	NRC	2	870 MTHM	
	Byron 1 & 2	Nuclear Power Plant Pool	Wet Storage	Exelon Generation Company	NRC	2	960 MTHM	
	Clinton 1	Nuclear Power Plant Pool	Wet Storage	Exelon Generation Company	NRC	2	390 MTHM	
	Dresden	ISFSI	Dry Storage	Exelon Generation Company	NRC	2	290 MTHM	
	Dresden 1 (shutdown), Dresden 2 & 3	Nuclear Power Plant Pools	Wet Storage				1,060 MTHM	
	GE Morris	ISFSI	Wet Storage	General Electric Co.	NRC	2	670 MTHM	
	LaSalle County 1 & 2	Nuclear Power Plant Pools	Wet Storage	Exelon Generation Company	NRC	2	1,010 MTHM	
	Quad Cities	ISFSI	Dry Storage	Exelon Generation Company	NRC	2	170 MTHM	
	Quad Cities 1 & 2	Nuclear Power Plant Pools	Wet Storage	Exelon Generation Company	NRC	2	1,130 MTHM	
	Zion 1 & 2 (shutdown)	Nuclear Power Plant Pools	Wet Storage				1,020 MTHM	
Iowa	Duane Arnold	ISFSI	Dry Storage	FPL Energy	NRC	2	110 MTHM	
	Duane Arnold	Nuclear Power Plant Pool	Wet Storage				310 MTHM	
Kansas	Wolf Creek 1	Nuclear Power Plant Pool	Wet Storage	Wolf Creek Nuclear Operating Corporation	NRC	2	540 MTHM	
Louisiana	River Bend	ISFSI	Dry Storage	Entergy Nuclear Operations	NRC	2	50 MTHM	

**Annex D-1 Spent Fuel Management Facilities**

State	Installation	Facility	Function	Licensee	Regulator	SF <sup>161</sup> Source	Inventory	Estimated Activity (Bq)
	River Bend 1	Nuclear Power Plant Pool	Wet Storage	Entergy Nuclear Operations	NRC	2	460 MTHM	
	Waterford 3	Nuclear Power Plant Pool	Wet Storage	Entergy Nuclear Operations	NRC	2	520 MTHM	
Maine	Maine Yankee (shutdown)	ISFSI	Dry Storage	Maine Yankee Atomic Power Company	NRC	2	540 MTHM	
Maryland	Calvert Cliffs	ISFSI	Dry Storage	Constellation Energy	NRC	2	560 MTHM	
	Calvert Cliffs 1 & 2	Nuclear Power Plant Pools	Wet Storage				540 MTHM	
Massachusetts	Pilgrim 1	Nuclear Power Plant Pool	Wet Storage	Entergy Nuclear Operations	NRC	2	490 MTHM	
	Yankee Rowe (shutdown)	ISFSI	Dry Storage	Yankee Atomic Electric Company	NRC	2	130 MTHM	
Michigan	Big Rock Point (shutdown)	ISFSI	Dry Storage	Entergy Nuclear Operations	NRC	2	60 MTHM	
	D.C. Cook 1 & 2	Nuclear Power Plant Pool	Wet Storage	Indiana/Michigan Power company	NRC	2	1,230 MTHM	
	Dow Chemical Company (Midland)	Research/Test Reactor	Wet Storage	Dow Chemical Company			14.81 kgU	2.23E+14
	Enrico Fermi 2	Nuclear Power Plant Pool	Wet Storage	Detroit Edison Company	NRC	2	440 MTHM	
	Palisades	ISFSI	Dry Storage	Entergy Nuclear Operations	NRC	2	330 MTHM	
	Palisades	Nuclear Power Plant Pool	Wet Storage				230 MTHM	
Minnesota	Monticello	Nuclear Power Plant Pool	Wet Storage	Nuclear Management Company	NRC		300 MTHM	
	Prairie Island	ISFSI	Dry Storage	Nuclear Management Company	NRC	2	360 MTHM	
	Prairie Island 1 & 2	Nuclear Power Plant Pool	Wet Storage				380 MTHM	
Mississippi	Grand Gulf	ISFSI	Dry Storage	Entergy Nuclear Operations	NRC	2	50 MTHM	
	Grand Gulf 1	Nuclear Power Plant Pool	Wet Storage				650 MTHM	
Missouri	Callaway 1	Nuclear Power Plant Pool	Wet Storage	AmerenUE	NRC	2	590 MTHM	
Nebraska	Cooper Station	Nuclear Power Plant Pool	Wet Storage	Nebraska Public Power District	NRC	2	360 MTHM	
	Fort Calhoun	ISFSI	Dry Storage	Omaha Public Power District	NRC	2	50 MTHM	
	Fort Calhoun	Nuclear Power Plant Pool	Wet Storage				310 MTHM	
New Hampshire	Seabrook 1	Nuclear Power Plant Pool	Wet Storage	FPL Energy			400 MTHM	

**Annex D-1 Spent Fuel Management Facilities**

State	Installation	Facility	Function	Licensee	Regulator	SF <sup>161</sup> Source	Inventory	Estimated Activity (Bq)
New Jersey	Hope Creek/Salem <sup>164</sup>	ISFSI	Dry Storage	PSE&G Nuclear	NRC	2	50 MTHM	
	Hope Creek/Salem 1 & 2	Nuclear Power Plant Pools	Wet Storage				1,550 MTHM	
	Oyster Creek	ISFSI	Dry Storage	Exelon Generation Company	NRC	2	170 MTHM	
	Oyster Creek	Nuclear Power Plant Pool	Wet Storage				380 MTHM	
New York	Fitzpatrick	ISFSI	Dry Storage	Entergy Nuclear Operations	NRC	2	110 MTHM	
	Fitzpatrick	Nuclear Power Plant Pool	Wet Storage				440 MTHM	
	Ginna	Nuclear Power Plant Pool	Wet Storage	Constellation Energy	NRC	2	390 MTHM	
	Indian Point 1 (shutdown), Indian Point 2 & 3	Nuclear Power Plant Pools	Wet Storage	Entergy Nuclear Operations	NRC	2	1,090 MTHM	
	Nine Mile Point 1 & 2	Nuclear Power Plant Pools	Wet Storage	Constellation Energy	NRC	2	960 MTHM	
North Carolina	Brunswick 1 & 2	Nuclear Power Plant Pools	Wet Storage	Progress Energy	NRC	2	690 MTHM *	
	Shearon Harris 1	Nuclear Power Plant Pools	Wet Storage				1,080 MTHM *	
	McGuire	ISFSI	Dry Storage	Duke Energy Power Company	NRC	2	330 MTHM	
	McGuire 1 & 2	Nuclear Power Plant Pools	Wet Storage				980 MTHM *	
Ohio	Davis-Besse	ISFSI	Dry Storage	FirstEnergy Nuclear Operating Company	NRC	2	30 MTHM	
	Davis-Besse 1	Nuclear Power Plant Pool	Wet Storage				440 MTHM	
	Perry 1	Nuclear Power Plant Pool	Wet Storage	FirstEnergy Nuclear Operating Company	NRC	2	530 MTHM	
Oregon	Trojan (shutdown)	ISFSI	Dry Storage	Portland General Electric	NRC	2	360 MTHM	
Pennsylvania	Beaver Valley 1 & 2	Nuclear Power Plant Pools	Wet Storage	FirstEnergy Nuclear Operating Company	NRC	2	880 MTHM	
	Limerick 1 & 2	Nuclear Power Plant Pools	Wet Storage	Exelon Generation Company	NRC	2	1,060 MTHM	
	Peach Bottom	ISFSI	Dry Storage	Exelon Generation Company	NRC	2	450 MTHM	
	Peach Bottom 2 & 3	Nuclear Power Plant Pools	Wet Storage				1,040 MTHM	
	Susquehanna	ISFSI	Dry Storage	PPL Susquehanna	NRC	2	450 MTHM	
	Susquehanna 1 & 2	Nuclear Power Plant Pools	Wet Storage				770 MTHM	
	Three Mile Island 1	Nuclear Power Plant Pool	Wet Storage	Exelon Generation Company	NRC	2	530 MTHM	

<sup>164</sup> Hope Creek and Salem nuclear power plants have a combined ISFSI



**Annex D-1 Spent Fuel Management Facilities**

State	Installation	Facility	Function	Licensee	Regulator	SF <sup>161</sup> Source	Inventory	Estimated Activity (Bq)
South Carolina	Catawba	ISFSI	Dry Storage	Duke Energy Power Company	NRC	2	30 MTHM	
	Catawba 1 & 2	Nuclear Power Plant Pools	Wet Storage				1,040 MTHM	
	Oconee	ISFSI	Dry Storage	Duke Energy Power Company	NRC	2	1,050 MTHM	
	Oconee 1, 2 & 3	Nuclear Power Plant Pools	Wet Storage				700 MTHM *	
	Robinson	ISFSI	Dry Storage	Progress Energy	NRC	2	70 MTHM	
	Robinson 2	Nuclear Power Plant Pool	Wet Storage				190 MTHM *	
	Summer	Nuclear Power Plant Pool	Wet Storage	South Carolina Electric & Gas Company	NRC	2	430 MTHM	
Tennessee	Sequoyah	ISFSI	Dry Storage	Tennessee Valley Authority	NRC	2	200 MTU	
	Sequoyah 1 & 2	Nuclear Power Plant Pool	Wet Storage				820 MTHM	
	Watts Bar 1	Nuclear Power Plant Pool	Wet Storage	Tennessee Valley Authority	NRC	2	260 MTHM	
Texas	Comanche Peak 1 & 2	Nuclear Power Plant Pools	Wet Storage	Luminant Generation	NRC	2	740 MTHM	
	South Texas 1 & 2	Nuclear Power Plant Pools	Wet Storage	STP Nuclear Operating Company	NRC	2	910 MTHM	
Utah	Private Fuel Storage	ISFSI	Dry Storage	PFS LLC	NRC	2	0 MTU	
Vermont	Vermont Yankee	Nuclear Power Plant Pool	Wet Storage	Energy Nuclear Operations	NRC	2	550 MTHM	
Virginia	BWX Technology, Inc.	Fuel Facility	Dry storage	BWX Technology, Inc.	NRC		43.5 kgU	2.48E+15
	North Anna	ISFSI	Dry Storage	Dominion Generation	NRC	2	390 MTHM	
	North Anna 1 & 2	Nuclear Power Plant Pool	Wet Storage				690 MTHM	
	Surry	ISFSI	Dry Storage	Dominion Generation	NRC	2	720 MTHM	
	Surry 1 & 2	Nuclear Power Plant Pool	Wet Storage				370 MTHM	
Washington	Columbia Gen. Station	ISFSI	Dry Storage	Energy Northwest	NRC	2	180 MTHM	
	Columbia	Nuclear Power Plant Pool	Wet Storage				370 MTHM	
Wisconsin	Kewaunee	Nuclear Power Plant Pool	Wet Storage	Dominion Generation	NRC	2	410 MTHM	
	LaCrosse (shutdown)	Nuclear Power Plant Pool	Wet Storage	Dairyland Power Cooperative	NRC	2	40 MTHM	
	Point Beach	ISFSI	Dry Storage	FPL Energy	NRC	2	260 MTHM	
	Point Beach 1 & 2	Nuclear Power Plant Pool	Wet Storage				490 MTHM	

\*Shared pools

**Annex D-2 Radioactive Waste Management Facilities<sup>165</sup>**

State	Installation	Licensee	Regulator	Facility	Function	Waste Source	Inventory (m3)	Estimated Activity (Bq)	Rad Cat
<b>Government Facilities</b>									
California	Lawrence Berkeley National Lab	DOE	DOE	Mixed/LLW Waste Facilities	Mixed/LLW Storage	2	2		6
		DOE	DOE	TRU Waste Facilities	TRU Storage	2	<1		6
	Lawrence Livermore National Lab	DOE	DOE	Various Waste Facilities	Mixed/LLW Storage		921		1,2,3,4,5
					TRU Storage		2,900		3
Idaho	Idaho National Laboratory	DOE	DOE	HLW Calciner	HLW Treatment (evaporation and calcination)	1	0		
		DOE	DOE	Calcined Solids Storage Facility	Calcined HLW Storage in underground tanks/bins	1	4,400	1.11E+18	
		DOE	DOE	HLW Tank Farm	HLW Liquid Storage in underground tanks	1	3,400		
		DOE	DOE	Radioactive Waste Management Complex	LLW Disposal in shallow land disposal facility	1	61,000	2.5E+17	1,2,3,4,5
		DOE	DOE	Idaho CERCLA Disposal Facility	LLW Disposal in engineered surface disposal cell for D&D wastes	1	203,000		
		DOE	DOE	TRU Waste Storage Facilities	TRU Storage	1	59,370		3
		DOE	DOE	Advanced Mixed Waste Treatment Plant	TRU characterization, treatment, and packaging	1	0		
		DOE	DOE/ID	MLLW Facilities	Storage, characterization, treatment, packaging	1	300	7.5E+9	1,2,3,4,5
		DOE	DOE/ID	MLLW Facilities	LLW	1	2,760		
Kentucky	Paducah Gaseous Diffusion Plant	DOE	DOE/KY	MLLW Facilities	MLLW Storage, characterization, treatment, packaging	1	1,580		3,4
		DOE	DOE/KY	LLW Facilities	LLW Storage, characterization, treatment, packaging		1,470		3,4
Missouri	Weldon Spring Site Rem. Action	DOE	DOE	On-Site Disposal Cell	11e.(2) Disposal in engineered, surface disposal cell	1	1,120,000		4
Multiple States <sup>166</sup>	Other DOE	DOE	DOE/Other states	Mixed/LLW Facilities (small)	Mixed/LLW Storage, characterization, treatment, packaging	1	1,800		6
		DOE	DOE	TRU Waste	TRU Storage	1	88		6

<sup>165</sup> See Key to Annex D-2 on last page of this table.

<sup>166</sup> There are multiple sites with labs, processing facilities or waste generated from D&D, e.g., Argonne National Laboratory, Ames Laboratory, Fermi Laboratory, Energy Technology Engineering Center, Laboratory for Energy-Related Health Research, Inhalation Toxicology Research Institute, and Princeton Plasma Physics Laboratory.

**Annex D-2 Radioactive Waste Management Facilities<sup>165</sup>**

State	Installation	Licensee	Regulator	Facility	Function	Waste Source	Inventory (m3)	Estimated Activity (Bq)	Rad Cat
				Facilities (small)					
Nevada	Nevada Test Site	DOE	DOE	Greater Confinement Disposal	TRU Disposal in boreholes	1	200	2.11E+15	1,2,3,4,5
		DOE	DOE/NV	MW Disposal Unit	MLLW Disposal in shallow trenches	1	9,790	4.5E+13	1,2,3,4,5
		DOE	DOE/NV	LLW Storage Facility	LLW Storage		803		
		DOE	DOE	Area 3/Area 5 RWMS	LLW Disposal in trenches and subsidence craters	1	991,000	4.7E+17	1,2,3,4,5
		DOE	DOE	TRU Waste Facilities	TRU Storage, characterization, packaging	1	300		
	Yucca Mountain Site	DOE	NRC	Geologic Repository (proposed at Yucca Mountain, Nevada)	SF/HLW Disposal	1,3	0	0	
New Mexico	Los Alamos National Laboratory	DOE	DOE	TRU Waste Facilities	TRU Storage, characterization, packaging	1	15,098		3
		DOE	DOE	Technical Area 54/Area G	LLW Disposal in shallow land disposal facility	1	245,000	8.3E+16	1,2,3,4,5
		DOE	DOE	Sealed Source Facilities	Disused Sealed Source Storage	1	676 Containers	5.87E+14	6
	Sandia National Laboratory - NM	DOE	DOE	TRU Waste Facilities	TRU Storage, characterization, packaging	1	45		6
		DOE	DOE/NM	Mixed/LLW Facilities	Mixed/LLW Storage, characterization, treatment, packaging	1	122	9E+11	2,3,5
	Waste Isolation Pilot Plant	DOE	NMED/EPA	WIPP Disposal	TRU Disposal in deep salt formation <sup>167</sup>	1	56,000	6.37E+16	1,2,3,4,5
New York	Niagara Falls Storage Site (FUSRAP)	COE	NY	Niagara Falls Storage Facility	11e.(2) Restoration Waste Storage		195,000		4
	West Valley Demonstration Project	DOE	DOE	HLW Glass Storage Cell	Interim storage of Vitrified HLW in a former process cell	3	229		2,3
		DOE	DOE/NY	MLLW Facilities	MLLW Storage, characterization, treatment, packaging	3	139		1,2,3,4,5
		DOE	DOE/NY	LLW Facilities	LLW Storage, characterization, treatment, packaging	3	2,260		
Ohio	Fernald Environmental Management Project	DOE	DOE	On-Site Disposal Facility	Mixed/LLW (from D&D) Disposal in engineered surface disposal cell	1	90		4
					LLW (from D&D) Disposal in engineered surface disposal cell	1	2,294,000		4

<sup>167</sup> As of April 14, 2008.

**Annex D-2 Radioactive Waste Management Facilities<sup>165</sup>**

State	Installation	Licensee	Regulator	Facility	Function	Waste Source	Inventory (m3)	Estimated Activity (Bq)	Rad Cat
		DOE	DOE/OH	11e.(2) Facilities	11e.(2) Storage, characterization, treatment, packaging	1	21,200 <sup>168</sup>		4
		DOE	DOE	LLW Waste Facilities	LLW Storage, characterization, packaging	1	13,500		3,4
	Miamisburg Environmental Management Project	DOE	DOE	MLLW Facilities	MLLW Storage, treatment, packing	1	1,200		
	Portsmouth Gaseous Diffusion Plant	DOE	DOE/OH	MLLW Facilities	MLLW Storage, treatment, packaging	1	0		4
		DOE	DOE/OH	LLW Facilities	LLW Storage, treatment, packaging	1	2,380		4
South Carolina	Savannah River Site	DOE	DOE	TRU Waste Facilities	TRU Storage, characterization, packaging	1	1,042		3
		DOE	DOE	Glass Waste Storage Building	Interim Storage of Vitrified HLW <sup>169</sup>	1	2,056		1,2,3,4,5
		DOE	DOE	HLW Tank Farm	HLW Liquid Storage in underground double-shell, stainless steel tanks	1	140,000		1,2,3,4,5
		DOE	DOE	Defense Waste Processing Fac.	HLW Liquid Treatment (Vitrification)	1	0		
		DOE	DOE/SC	MLLW Facilities	MLLW Storage, characterization, treatment, packaging	1	205	3.45E+11	1,2,3,4,5
		DOE	DOE/SC	LLW Facilities	LLW Storage, characterization, treatment, packaging	1	0		1,2,3,4,5
		DOE	DOE	E-Area Disposal	Disposal of LLW in underground vaults and trenches	1	293,000	4.4E+16	1,2,3,4,5
		DOE	DOE	Old Burial Ground	Historic disposal of LLW	1	677,000		1,2,3,4,5
		DOE	DOE	Saltstone Vaults	Disposal of low-activity fraction of HLW	1	26,647		1,2,3,4,5
Tennessee	Oak Ridge Reservation	DOE	DOE	TRU Waste Facilities	TRU Storage, characterization, packaging	1	1,610		1,2,3,4
		DOE	DOE/TN	Toxic Substances Control Act Incinerator	MLLW treatment	1			1,2,3,4,5
		DOE	DOE/TN	MLLW Facilities	MLLW Storage (in building and on concrete pad), characterization, treatment, packaging	1	2,680		1,2,3,4,5
		DOE	DOE/TN	LLW Facilities	LLW Storage (in building and on concrete pad), characterization, treatment, packaging	1	8,450		1,2,3,4,5

<sup>168</sup> This inventory stored in off-site commercial facility.

<sup>169</sup> As of March 2008.

**Annex D-2 Radioactive Waste Management Facilities<sup>165</sup>**

State	Installation	Licensee	Regulator	Facility	Function	Waste Source	Inventory (m3)	Estimated Activity (Bq)	Rad Cat
		DOE	DOE	Environmental Management Waste Management Facility	LLW Disposal in engineered surface disposal cell for D&D wastes	1	590,000		
		DOE	DOE	Oak Ridge TRU Waste Treatment Facility	TRU waste treatment; also for liquid LLW supernate treatment and packaging	1	0		
		DOE	DOE	Interim Waste Management Fac.	LLW Disposal in engineered aboveground facility	1	3,700	1.18E+13	1,2,3,4,5
		DOE	DOE	Hydrofracture	Historic disposal of LLW		17,300		
		DOE	DOE	Old Burial Ground	Historic disposal of LLW		441,000		
Utah	Monticello Remedial Action Project	DOE	DOE	Monticello Disposal Cell	11e.(2) Disposal in engineered, surface disposal cell	1	1,910,000		4
Washington	Hanford Site	DOE	DOE	Decommissioned Submarine Hulls Disposal Area	LLW Navy submarine hulls disposal in trenches	1	117 reactor compartments		
		DOE	DOE	HLW Tank Farm	HLW Liquid Storage in underground single-and double-shell tanks	1	207,198		1,2,3,4,5
		DOE	DOE	Waste Encapsulation and Storage Facility	Cs-Sr Storage in hot cells and storage pool	1	1,929 sources	2.85E+18	
		DOE	DOE	TRU Waste Facilities	TRU Storage, characterization, packaging	1	15,200		1,2,3,4,5
		DOE	DOE/WA	RMW Trenches	MLLW Disposal in lined trenches	1	107,000	5.7E+16	1,2,3,4,5
		DOE	DOE	Environmental Restoration Disposal Facility	LLW (from D&D) Disposal in engineered surface disposal unit	1	492,000		1,2,3,4,5
		DOE	DOE	200 Area Burial Grounds	LLW Disposal in trenches	1	310,000	1.68E+17	1,2,3,4,5
		DOE	DOE	Integrated Disposal Facility (newly constructed awaiting start up)	MLLW Disposal	1			1,2,3,4,5
		DOE	DOE/WA	MLLW Facilities	MLLW Storage, characterization, treatment, packaging	1	1,420		1,2,3,4,5
DOE	DOE/WA	LLW Facilities	LLW Storage, characterization, treatment, packaging	1	1,210		1,2,3,4,5		
<b>Commercial Facilities</b>									
California	New World Technology	New World Technology	CA	New World Technology	Processor – Waste Treatment Service (Other than compactio3333n)	3	NA		

**Annex D-2 Radioactive Waste Management Facilities<sup>165</sup>**

State	Installation	Licensee	Regulator	Facility	Function	Waste Source	Inventory (m3)	Estimated Activity (Bq)	Rad Cat
	Thomas Grey Associates	Thomas Grey Associates	CA	Thomas Grey Associates	Processor – Processing of liquids and radium	3	NA		
Connecticut	Cabrera Services, Inc.	Cabrera Services, Inc.	NRC	Cabrera Services, Inc.	Processor – Decontamination Services	3	NA		
	Radiation Safety Associates	Radiation Safety Associates	NRC	Radiation Safety Associates	Processor	3	NA		
	Yale Univ. Radiation Safety Section	Yale University	NRC	Yale Univ. Radiation Safety Section	Processor – Academic Type A Broad	3	NA		
Illinois	ADCO Services Inc.	ADCO Services Inc.	IL	ADCO Services Inc.	Processor – Processing of uranium and thorium	3	NA		
	Dept. Of The Army Rock Island Arsenal	Dept. Of The Army	NRC	Dept. Of The Army	Processor – Waste Disposal Service Processing and/or Repackaging.	3	NA		
Maryland	Dept. Of The Army Ft. Detrick	Dept. Of The Army	NRC	Dept. Of The Army	Processor – Waste Disposal Service Processing and/or Repackaging.	3	NA		
	Ecology Services	Ecology Services	MD	Ecology Services	Processor – Mixed waste processing	3	NA		
	RSO, Inc.	RSO, Inc.	MD	RSO, Inc.	Processor – Organics processing	3	NA		
Michigan	Pharmacia & Upjohn Company	Pharmacia & Upjohn Company	NRC	Pharmacia & Upjohn Company	Processor – Manufacturing and Distribution Type A Broad	3	NA		
Minnesota	University of Minnesota	University of Minnesota	MN	University of Minnesota	Processor – Waste Disposal Service Processing and/or Repackaging.	3	NA		
Missouri	Pharmacia Corporation	Pharmacia Corporation	NRC	Pharmacia Corporation	Processor – Waste Disposal Service Processing and/or Repackaging.	3	NA		
	R.M. Wester	R.M. Wester	NRC	R.M. Wester	Processor	3	NA		
	Westinghouse Electric Company, LLC	Westinghouse Electric Company, LLC	NRC	Westinghouse Electric Company, LLC	Processor – Decommissioning of Uranium Fuel Fabrication Plants	3	NA		
Montana	HHS, Dept. Of USPHS, NIH, Rocky Mountain Laboratories	Dept. of Health & Human Services	NRC	HHS, Dept. Of USPHS, NIH, NIAID	Processor – Research and Development Type A Broad	3	NA		
New Jersey	BASF Corporation	BASF Corporation	NRC	BASF Corporation	Processor – Research and Development Type A Broad	3	NA		
	Radiation Science, Inc.	Radiation Science, Inc.	NRC	Radiation Science, Inc.	Processor – Waste Disposal Service Prepackaged only.	3	NA		
	Teledyne Brown Engineering, Inc.	Teledyne Brown Engineering, Inc.	NRC	Teledyne Brown Engineering, Inc.	Processor – Waste Disposal Service Prepackaged only.	3	NA		

**Annex D-2 Radioactive Waste Management Facilities<sup>165</sup>**

State	Installation	Licensee	Regulator	Facility	Function	Waste Source	Inventory (m3)	Estimated Activity (Bq)	Rad Cat
New York	Radiac Research Corp.	Radiac Research Corp.	NY	Radiac Research Corp.	Processor – Waste Disposal Service Prepackaged only.	3	NA		
North Carolina	HHS, Dept. Of Public Health Service	Dept. of Health & Human Services	NRC	HHS, Dept. Of Public Health Service	Processor – Research and Development Type A Broad	3	NA		
	V.A. Medical Center	Dept. of Veterans Affairs	NRC	V.A. Medical Center	Processor – Medical Institution Broad	3	NA		
Ohio	Solient Technologies	Solient Technologies	OH	Solient Technologies	Processor – Processing	3	NA		
Pennsylvania	Alaron Corporation	Alaron Corporation	PA	Alaron Corporation	Processor – Waste Disposal Service Processing and/or Repackaging.	3	NA		
	Applied Health Physics, Inc.	Applied Health Physics, Inc.	PA	Applied Health Physics, Inc.	Processor – Waste Disposal Service Prepackaged only.	3	NA		
	BWX Technologies, Inc. B&W Nuclear Environmental Services	BWX Technologies	NRC	BWX Technologies, Inc. B&W Nuclear Environmental Services	Processor – Decommissioning of Advanced Fuel R&D and Pilot Plants	3	NA		
	Fox Chase Cancer Center	Fox Chase Cancer Center	PA	Fox Chase Cancer Center	Processor – Medical Institution Broad	3	NA		
South Carolina	GTS-Duratek/Chem-Nuclear Systems, Inc.	GTS-Duratek, Inc	SC	GTS-Duratek/ Chem-Nuclear Systems, Inc.	Processor – Decommissioning of Byproduct Material Facilities	3	NA		
	Energy Solutions (Barnwell)	Energy Solutions (Barnwell)	SC	Barnwell Commercial Disposal	LLW Disposal Class A	3	715,974	7.17E+17	1,2,3,4,5
					LLW Disposal Class B	3	52,319		
LLW Disposal Class C					3	26,093			
Tennessee	Bionomics	Bionomics	TN	Bionomics	Processor	3	NA		
	Chase Environmental	Chase Environmental Group, Inc.	TN	Chase Environmental	Processor	3	NA		
	Diversified Scientific Services, Inc. (DSSI)	(DSSI)	TN	DSSI	Processing of resins, sludges, and liquids	3	NA		
	Energy Solutions LLC	Energy Solutions	TN	Bear Creek	Processor	3	NA		
	Energy Solutions LLC	Duratek Services, inc.	TN	Manufacturing Sciences Corporation	Processor – Processing of uranium, thorium, other	3	NA		

**Annex D-2 Radioactive Waste Management Facilities<sup>165</sup>**

State	Installation	Licensee	Regulator	Facility	Function	Waste Source	Inventory (m3)	Estimated Activity (Bq)	Rad Cat
	Impact Services, Inc.	Impact Services, Inc.	TN	Impact Services, Inc.	Processor	3	NA		
	Perma-fix	Perma-fix Environmental Services, Inc.	TN	Perma-fix	Processing/treatment of mixed wastes	3	NA		
	Philotechnics	Philotechnics, Ltd.	TN	Philotechnics	Processor -- Processing of uranium and thorium salts	3	NA		
	Studsvik	Studsvik Processing Facility Memphis, LLC	TN	Formerly RACE, LLC	Processor – Processing of large equipment	3	NA		
	Studsvik	Studsvik Processing Facility Erwing, TN	TN	Studsvik	Processing Treatment				
	Toxco Incorporated	Toxco Incorporated	TN	Toxco	Processor	3	NA		
	V.A. Medical Center	Dept. of Veterans Affairs	NRC	V.A. Medical Center	Processor – High Dose Rate Remote Afterloader	3	NA		
Texas	MKM Engineers, Inc.	MKM Engineers, Inc.	TX	MKM Engineers, Inc.	Processor – Waste Disposal Service Processing and/or Repackaging.	3	NA		
	NSSI	NSSI	TX	NSSI	MLLW processing	3	NA		
	Specpro, Inc.	Specpro, Inc.	TX	Specpro, Inc.	Processor – Waste Disposal Service Processing and/or Repackaging.	3	NA		
	Waste Control Specialists (WCS)	WCS	TX	Waste Control Specialists	GTCC Storage		43		
					MLLW Treatment	3	NA		
					11e.(2) Storage and Disposal		21,200		
Utah	EnergySolutions	EnergySolutions	UT	Clive	MLLW Treatment and Disposal	3	91,448		1,2,3,4,5
					LLW --Class A Disposal	3	2,639,611	2.09E+14	1,2,3,4,5
					11e.(2) Disposal	3	1,230,000		1,2,3,4,5
Washington	Permafex Northwest	Permafex Northwest	WA	Allied Technology Group	MLLW treatment and processing	3	NA		
	U.S. Ecology - Richland	U.S. Ecology	WA	U.S. Ecology <sup>170</sup>	LLW--Class A Disposal	3	384,885	2.70E+17	1,2,3,4,5
					LLW--Class B Disposal	3	3,703		
LLW--Class C Disposal	3	2,761							
Wisconsin	Covance Laboratories	Covance Laboratories	WI	Covance Laboratories	Processor – Research and Development Other	3	NA		
	William S. Middleton Memorial V.A. Hospital	Dept. of Veterans Affairs	NRC	William S. Middleton Memorial Veterans Hospital	Processor – Medical Institution Broad	3	NA		

<sup>170</sup> From Greater-than-Class C Low Level Waste: Inventory Estimates, July 2007.



**Annex D-2 Radioactive Waste Management Facilities<sup>165</sup>**

State	Installation	Licensee	Regulator	Facility	Function	Waste Source	Inventory (m3)	Estimated Activity (Bq)	Rad Cat
Multiple States	Beatty, NV; Maxey Flats, KY; Sheffield, IL; West Valley, NY	None	NV, KY, IL, NY	Closed Commercial Disposal	LLW—All Classes	3	438,450	7.81E+16	1,2,3,4,5
	Multiple ISFSIs	Various utilities	NRC	NPPs	GTCC Storage <sup>171</sup>		87		
<b>Past Practices</b>									
Ocean Disposal				Atlantic	LLW		8,600	2.94E+15	
				Pacific	LLW		14,000	5.54E+14	

**Annex D-2 Key**

Waste Source	Radionuclide Category		
	Category	Key Isotopes	
1 Defense applications	1 Activation Products	Primarily <sup>36</sup> Cl, <sup>55</sup> Fe, <sup>54</sup> Mn, <sup>65</sup> Zn, <sup>58</sup> Co, <sup>60</sup> Co, <sup>63</sup> Ni,	
2 Nuclear applications	2 Mixed Fission Products	Radioactive isotopes and daughters from <sup>72</sup> Zn to <sup>158</sup> Gd; primary loner-lived isotopes are <sup>85</sup> Kr, <sup>89</sup> Sr, <sup>90/Y-90</sup> Sr, <sup>91</sup> Y, <sup>95</sup> Zr, <sup>95</sup> Nb, <sup>103/Rh</sup> 103Ru, <sup>106/Rh-106</sup> Ru, <sup>125/Te-125</sup> Sb, <sup>137/Ba-137</sup> Cs, <sup>141</sup> Ce, <sup>144/Pr-144</sup> Ce, <sup>147</sup> Pm, <sup>m151</sup> S, and <sup>155</sup> Eu	
3 Commercial	3 Transuranic Isotopes	Isotopes of Cf, Bk, Cm, Am, Pu, and Np, and their respective decay products.	
	4 Naturally-Occurring Isotopes	<sup>238</sup> U, <sup>235</sup> U, <sup>234</sup> U, <sup>232</sup> Th, and their respective decay products ( <sup>231</sup> Pa, <sup>227</sup> Th, <sup>228</sup> Th, <sup>230</sup> Th, <sup>231</sup> Th, <sup>234</sup> Th, <sup>227</sup> Ac, <sup>228</sup> Ac, <sup>223</sup> Ra, <sup>224</sup> Ra, <sup>226</sup> Ra, <sup>228</sup> Ra, <sup>223</sup> Fr, <sup>219</sup> Rn, <sup>220</sup> Rn, <sup>222</sup> Rn, <sup>215</sup> At, <sup>218</sup> At, <sup>219</sup> At, <sup>210</sup> Po, <sup>211</sup> Po, <sup>212</sup> Po, <sup>214</sup> Po, <sup>215</sup> Po, <sup>216</sup> Po, <sup>218</sup> Po, <sup>210</sup> Bi, <sup>211</sup> Bi, <sup>212</sup> Bi, <sup>214</sup> Bi, <sup>210</sup> Pb, <sup>211</sup> Pb, <sup>212</sup> Pb, <sup>214</sup> Pb, <sup>206</sup> Tl, <sup>207</sup> Tl, <sup>208</sup> Tl, and <sup>210</sup> Tl), <sup>14</sup> C, <sup>40</sup> K, <sup>40</sup> V, <sup>87</sup> Rb, <sup>115</sup> In, <sup>123</sup> Te, <sup>138</sup> La, <sup>142</sup> Ce, <sup>144</sup> Nd, <sup>147</sup> Sm, <sup>148</sup> Sm, <sup>149</sup> Sm, <sup>152</sup> Gd, <sup>156</sup> Dy, <sup>176</sup> Lu, <sup>174</sup> Hf, <sup>180</sup> Ta, <sup>187</sup> Re, <sup>190</sup> Pt, <sup>204</sup> Pb, <sup>215</sup> Bi	
	5 Tritium	<sup>3</sup> H	
	6 Various	Radioactivity from various sources and categories	

Note, unless otherwise indicated:

- TRU waste inventories are as of December 31, 2006.
- Mixed and Low-Level waste inventories are as of October 1, 2007.
- Disposal volumes are as of October 1, 2007.

<sup>171</sup> Disposal volumes through March 30, 2007.

**Annex D-3A Uranium Mill Tailings and Related Sites**

State	Site Name/ Location	Licensee	Type	Status	Regulator	Regulatory Program	Quantity of Contaminated Material (dry metric tonnes except as noted)	Total Ra-226 Activity (TBq)
Arizona	Tuba City	DOE	Surface residual radioactive material disposal cell	Under general NRC license, in DOE LTSP program; property owned by Navajo Indian Nation.	NRC	UMTRCA Title I	2,250,000	35
Colorado	Cheney Disposal Cell (residual radioactive material removed from the former Grand Junction Climax site)	DOE	Surface residual radioactive material disposal cell	Active until 2023 to accept residual radioactive material from other sites.	NRC	UMTRCA Title I	3,593,000 cubic meters	TBD
	Cotter	Cotter Corp. USA	Conventional mill	Standby/periodic limited operations	Colorado	UMTRCA Title II	2,000,000	NA
	Cotter Schwarzwald Mine	Cotter Corp. USA	Uranium mine ore separation and size reduction	Physical completion planned for 2009/Ore stockpiling under consideration.	Colorado	Colorado Mined Land Reclamation Act	6,150	NA
	Durita,	Hecla Mining Company	Heap Leach Site	Physical completion 1998. Reclamation/Stability monitoring	Colorado	UMTRCA Title II	540,000	NA
	Gunnison	DOE	Conventional mill and surface residual radioactive material disposal cell	Under general NRC license, in DOE LTSP program	NRC	UMTRCA Title I	1,140,000	6.5
	Homestake Mining and Pitch	Homestake Mining Company	Mine drainage treatment & residuals repository	US Forest Service land; joint regulation with Colorado Division of Reclamation Mining & Safety	US Forest Service & Colorado	UNTRCA Title II	NA	NA
	Maybell	DOE	Conventional mill and surface residual radioactive material disposal cell	Under general NRC license, in DOE LTSP program; annual groundwater monitoring inspections.	NRC	UMTRCA Title I	4,291,928	17
	UMETCO/ Maybell	DOE	Heap Leach Site	Not yet on LTSP. Surface reclamation complete.	Colorado	UMTRCA Title II	NA	NA

**Annex D-3A Uranium Mill Tailings and Related Sites**

State	Site Name/ Location	Licensee	Type	Status	Regulator	Regulatory Program	Quantity of Contaminated Material (dry metric tonnes except as noted)	Total Ra-226 Activity (TBq)
	Naturita	DOE	Surface residual radioactive material disposal cell	Under general NRC license, in DOE LTSP program.	NRC	UMTRCA Title I	971,762	2.9
	Rifle	DOE	Surface residual radioactive material disposal cell	Under general NRC license, in DOE LTSP program	NRC	UMTRCA Title I	4,967,451	101
	Slick Rock	DOE	Surface residual radioactive material disposal cell	Under general NRC license, in DOE LTSP program	NRC	UMTRCA Title I	1,140,000	6.5
	Sweeney	EPA Superfund	Conventional mill	No activity; site under State Order	Colorado	UMTRCA Title II	NA	NA
	UMETCO/ Uravan	EPA Superfund	Conventional mill	Reclamation/decommissioning	Colorado	UMTRCA Title II	9,500,000	NA
Idaho	Lowman	DOE	Surface residual radioactive material disposal cell	Under general NRC license, in DOE LTSP program	NRC	UMTRCA Title I	222,230	0.4
Illinois	TRONOX (Formerly Kerr McGee) West Chicago	Kerr-McGee	Conventional thorium mill	Decommissioning. The West Chicago site is being decommissioned for unrestricted use. Anticipate finishing cleanup in 2010	Illinois	UMTRCA Title II	Materials relocated to Utah disposal site.	NA
Nebraska	Crow Butte	Crow Butte Resources, Inc.	<i>In situ</i> site	Operating	NRC	UMTRCA Title II	NA	NA
New Mexico	Ambrosia Lake	DOE	Conventional mill and surface residual radioactive material disposal cell	Under general NRC license, in DOE LTSP program	NRC	UMTRCA Title I	6,931,000	69
	Ambrosia Lake	Rio Algom Mining LLC	Conventional mill	Not yet on LTSP. Mill decommissioned in 2003, surface reclamation projected finish 2010 {possible license transfer and new mill construction}	NRC	UMTRCA Title II	30,100,000	NA
	Bluewater	DOE	Conventional mill and surface mill tailings disposal cell	Under general NRC license, in DOE LTSP program	NRC	UMTRCA Title II	24,000,000	457

**Annex D-3A Uranium Mill Tailings and Related Sites**

State	Site Name/ Location	Licensee	Type	Status	Regulator	Regulatory Program	Quantity of Contaminated Material (dry metric tonnes except as noted)	Total Ra-226 Activity (TBq)
	Church Rock	United Nuclear Corporation Mining and Milling	Conventional mill; groundwater restoration program	Not yet on LTSP. DP <sup>172</sup> approved 3/1991, groundwater restoration projected finish in 2011	NRC	UMTRCA Title II	3,200,000	NA
	Crown Point	Hydro Resources, Inc.	<i>In situ</i> site	Partially permitted	NRC	UMTRCA Title II	NA	NA
	Grants	Homestake Mining Co	Conventional mill; groundwater restoration program	Not yet on LTSP. Revised DP approved 3/1995, groundwater restoration projected finish 2017	NRC	UMTRCA Title II	20,300,000	NA
	L-Bar (Sohio Western Mining)	DOE	Conventional mill and surface mill tailings disposal cell	Under general NRC license, in DOE LTSP program	NRC	UMTRCA Title II	1,900,000	NA
	Shiprock	DOE	Conventional mill and surface residual radioactive material disposal cell	Under general NRC license, in DOE LTSP program	NRC	UMTRCA Title I	2,520,000 wet metric tonnes	28
Oklahoma	Sequoyah Fuels Corporation	Sequoyah Fuels Corp.	UF <sub>6</sub> Facility	NRC reviewing the groundwater corrective action plan; cleanup estimate completion by end of 2012.	NRC	UMTRCA Title II	248,318 cubic meters	0.11
Oregon	Lakeview	DOE	Conventional mill and surface residual radioactive material disposal cell	Under general NRC license, in DOE LTSP program	NRC	UMTRCA Title I	736,000	1.6
Pennsylvania	Burrell	DOE	Surface residual radioactive material disposal cell	Under general NRC license, in DOE LTSP program; groundwater monitoring and maintenance program to maintain site integrity.	NRC	UMTRCA Title I	86,000	0.15

<sup>172</sup>DP= Decommissioning Plan

**Annex D-3A Uranium Mill Tailings and Related Sites**

State	Site Name/ Location	Licensee	Type	Status	Regulator	Regulatory Program	Quantity of Contaminated Material (dry metric tonnes except as noted)	Total Ra-226 Activity (TBq)
	Canonsburg	DOE	Conventional mill and surface residual radioactive material disposal cell	Under general NRC license, in DOE LTSP program; surface and groundwater under monitoring regime.	NRC	UMTRCA Title I	226,000	4
South Dakota	Edgemont	DOE	Conventional mill and surface mill tailings disposal cell	Under general NRC license, in DOE LTSP program	NRC	UMTRCA Title II	4,000,000	19
Texas	Cogema Mining Inc./ Bruni	Cogema	<i>In situ</i> site	Restoration/Closure under way	Texas	UMTRCA Title II	NA	NA
	Conoco Conquista	Conoco Conquista	Conventional mill	All structures and equipment have been removed from site & tailings impoundment has been capped with a vegetative cover. Reclamation/Stability monitoring	Texas	UMTRCA Title II	11,800,000	NA
	Hobson, Tex-1 & Mt. Lucas Projects/ Dinero (3 locations)	Everest Exploration, Inc	<i>In situ</i> sites	Hobson is an active sites; Tex-1 & Mt. Lucas in reclamation phases.	Texas	UMTRCA Title II	NA	NA
	Ray Point Felder	Exxon	Conventional mill	All structures and equipment have been removed from site & tailings impoundment has been capped with a vegetative cover. Reclamation/Stability monitoring	Texas	UMTRCA Title II	400,000	NA
	Falls City	DOE	Conventional mill and surface residual radioactive material disposal cell	Under general NRC license, in DOE LTSP program.	NRC	UMTRCA Title I	7,143,000	47
	Zamzow & Lamprech Projects /S. Texas	International Energy Corporation	<i>In situ</i> sites	Restoration/Closure under way	Texas	UMTRCA Title II	NA	NA

**Annex D-3A Uranium Mill Tailings and Related Sites**

State	Site Name/ Location	Licensee	Type	Status	Regulator	Regulatory Program	Quantity of Contaminated Material (dry metric tonnes except as noted)	Total Ra-226 Activity (TBq)
	Alta Mesa	Mestena Uranium LLC	<i>In situ</i> site	Operational	Texas	UMTRCA Title II	NA	NA
	RGR/Chevron (aka Panna Maria)	Rio Grande Resources Corporation	Conventional mill	All structures and equipment have been removed from site & tailings impoundment has been capped with a vegetative cover. Reclamation/Stability monitoring	Texas	UMTRCA Title II	5,900,000	NA
	Kingsville Dome	URI	<i>In situ</i> site	Operational	Texas	UMTRCA Title II	NA	NA
	Vasquez	URI	<i>In situ</i> site	Operational	Texas	UMTRCA Title II	NA	NA
Utah	Green River	DOE	Conventional mill and surface residual radioactive material disposal cell	Under general NRC license, in DOE LTSP program; groundwater monitoring regime.	NRC	UMTRCA Title I	501,000	1.1
	Lisbon	Rio Algom Mining Corp	Conventional mill	Not yet on LTSP; reclamation completion in 2010. This is a candidate for restart.	Utah	UMTRCA Title II	3,500,000	NA
	Mexican Hat	DOE	Conventional mill and surface residual radioactive material disposal cell	Under general NRC license, in DOE LTSP program	NRC	UMTRCA Title I	4,400,000	67
	Moab	DOE	Mill & Tailings Disposal	Under active reclamation by DOE; site will not come under general license in 10 CFR 40.27 until surface reclamation is complete	NRC	UMTRCA Title I	10,800,000	NA
	Salt Lake City Disposal Cell (Clive)	DOE	Surface residual radioactive material disposal cell	Under general NRC license, in DOE LTSP program.	NRC	UMTRCA Title I	2,798,000	57
	Salt Lake City Processing Site Central Valley Water	DOE	Currently a sewage treatment facility	Institutional controls maintained by DOE	DOE	UMTRCA Title I	Residual Ra-226-and Th-230-contaminated material.	NA

**Annex D-3A Uranium Mill Tailings and Related Sites**

State	Site Name/ Location	Licensee	Type	Status	Regulator	Regulatory Program	Quantity of Contaminated Material (dry metric tonnes except as noted)	Total Ra-226 Activity (TBq)
	Reclamation Facility							
	Shootaring Canyon	Plateau Resources Ltd	Conventional uranium mill	On standby status	Utah	UMTRCA Title II	15,300 cubic meters – only operated for 3 months.	NA
	White Mesa	International Uranium Corporation	Conventional uranium mill	Operating, capable of processing alternate feed	Utah	UMTRCA Title II	3,200,000	NA
Washington	Dawn Mining	Dawn Mining Company	Conventional uranium mill	Reclamation/Residue Disposal. Final reclamation December 31, 2013.	WA <sup>173</sup>	UMTRCA Title II	2,800,000	NA
	WNI Sherwood	DOE	Conventional uranium mill	Under general NRC license, in DOE LTSP program.	NRC	UMTRCA Title II	2,600,000	17
Wyoming	Bear Creek	Bear Creek Uranium Co	Conventional uranium mill	Not yet on LTSP. DP approved 5/1989;reclamation completion by 2010.	NRC	UMTRCA Title II	4,300,000	NA
	Gas Hills	American Nuclear Corporation	Conventional uranium mill	Not yet on LTSP. DP approved 10/1998; reclamation completion by 2011.	NRC	UMTRCA Title II	7,300,000	NA
	Gas Hills	Pathfinder Mines Corp -- Lucky MC	Conventional uranium mill	Not yet on LTSP. Revised DP approved 6/1996, revised in 1998.	NRC	UMTRCA Title II	10,600,000	NA
	East Gas Hills	Umetco Minerals Corp	Conventional uranium mill	Not yet on LTSP. Revised DP approved 4/2001(soil)	NRC	UMTRCA Title II	7,300,000	NA
	Highlands	Exxon Mobil Corp	Conventional uranium mill	Not yet on LTSP. DP approved 1990;	NRC	UMTRCA Title II	10,300,000	NA

<sup>173</sup> WA – State of Washington

**Annex D-3A Uranium Mill Tailings and Related Sites**

State	Site Name/ Location	Licensee	Type	Status	Regulator	Regulatory Program	Quantity of Contaminated Material (dry metric tonnes except as noted)	Total Ra-226 Activity (TBq)
				reclamation completion in 2010.				
	Christensen Ranch	COGEMA Mining, Inc.	<i>In situ</i> site	Application under review to restart facility	NRC	UMTRCA Title II	NA	NA
	Shirley Basin	Pathfinder Mines Corp	Conventional uranium mill	Not yet on LTSP. Revised DP approved 12/1997; candidate for re-start.	NRC	UMTRCA Title II	7,400,000	NA
	Shirley Basin	DOE	Conventional uranium mill	Under general NRC license, in DOE LTSP program	NRC	UMTRCA Title II	6,300,000	NA
	Smith Ranch – Highland	Power Resources, Inc.	<i>In situ</i> site	Operating	NRC	UMTRCA Title II	NA	NA
	Split Rock	Western Nuclear Inc.	Conventional uranium mill	Not yet on LTSP. DP approved 1997	NRC	UMTRCA Title II	7,000,000	NA
	Spook	DOE	Conventional mill and surface residual radioactive material disposal cell	Under general NRC license, in DOE LTSP program.	NRC	UMTRCA Title I	1,500,000 cubic meters	NA
	Sweetwater	Kennecott Uranium Co	Conventional uranium mill	On standby status	NRC	UMTRCA Title II	2,100,000	NA

Sources: [http://www.lm.doe.gov/pro\\_doc/references/framework.htm](http://www.lm.doe.gov/pro_doc/references/framework.htm); <http://www.radiationcontrol.utah.gov/>  
<http://www.cdphe.state.co.us/hm/rptailing.htm>; <http://www.doh.wa.gov/ehp/rp/waste/dmchm.htm>  
<http://www.eia.doe.gov/cneaf/nuclear/dupr/dupr.html>



**Annex D-3B Expected New Uranium Recovery Facility Applications / Restarts / Expansions<sup>174</sup>**

Company	Site	Design type	Estimated Application Date	State	Letter of Intent
<b>Fiscal 2007 Applications</b>					
Cogema	Christensen Ranch	ISL - Restart	Received April 2007	WY	None
Cameco (Crow Butte Resources, Inc.)	North Trend	ISL - Expansion	Received June 2007	NE	None
Cameco (Crow Butte Resources, Inc.)	Plant Upgrade	ISL - Expansion	Received October 2006 Completed December 2007	NE	None
<b>Fiscal 2008 Applications</b>					
Lost Creek ISR, LLC	Lost Creek	ISL - New	Received October 2007	WY	05/23/07
Uranium One (Energy Metals Corp.)	Moore Ranch	ISL - New	Received October 2007	WY	05/31/07
Uranium One (Energy Metals Corp.)	Jab and Antelope	ISL - New	Received September 2008	WY	05/31/07
Uranerz Energy Corp.	Hank and Nichols	ISL - New	Received December 2007	WY	06/27/07
<b>Fiscal 2009 Applications</b>					
Powertech Uranium Corp.	Dewey Burdock	ISL - New	October 2008	SD	01/26/07
Strathmore Minerals Corp	Roca Honda	Conv. - New	April 2009	NM	04/23/07
Strathmore Minerals Corp	Sky	ISL - New	April 2009	WY	05/11/07
Uranium Energy Corporation	Grants Ridge	Heap-Leach- New	July 2009	NM	02/22/08
Uranerz Energy Corporation	Collins Draw	ISL-New	July 2009	WY	03/20/08
Uranium One (Energy Metals Corp.)	Ludeman	ISL-New	October 2008	WY	03/20/08
Kennecott Uranium Co.	Sweetwater	Resin Elution- Expansion	January 2009	WY	03/20/08
Cameco (Crow Butte Resources, Inc.)	Three Crow	ISL - Expansion	February 2009	NE	03/20/08
Cameco (Power Resources Inc.)	Smith Ranch/Highland CPP	ISL - Expansion	May 2009	WY	03/20/08
UR-Energy Corp.	Lost Soldier	ISL - New	January 2009	WY	03/20/08
Wildhorse Energy	West Alkali Creek	ISL - New	December 2009	WY	03/20/08
Uranium One (Energy Metals Corp.)	Allemand-Ross	ISL - New	August 2009	WY	03/20/08
Rio Grande Resources	Mt. Taylor	Conv. - New	August 2009	NM	03/21/08
Lost Creek ISR, LLC	Lost Creek	ISL- Expansion	October 2008	WY	03/21/08
<b>Fiscal 2010 Applications</b>					
Cameco (Power Resources, Inc.)	Ruby Ranch	ISL-New	October 2009	WY	03/20/08
Strathmore Minerals Corporation	Reno Creek	ISL-New	December 2009	WY	03/21/08
Neutron Energy	Marquez	Conv.-New	April 2010	NM	03/25/08

<sup>174</sup> Note that some of these sites are also listed in Annex D-3A

**Annex D-3B Expected New Uranium Recovery Facility Applications / Restarts / Expansions<sup>174</sup>**

**Fiscal 2011 Applications**

Strathmore Minerals Corporation	Gas Hills	Conv. - New	February 20 11	WY	03/21/08
Cameco (Crow Butte Resources, Inc.)	Marsland	ISL-Expansion	November 2010	NE	03/20/08
Wildhorse Energy	Sweetwater	ISL and Conv. - New	May 2011	WY	-
Concentric	Yavapai County	Conv.- New	October -2010	AZ	03/20/08

ISL = *In situ* Leach Facility  
 Conv = Conventional Uranium Mill  
 FY = Fiscal Year

**Annex D-4 Pending and Ongoing DOE Decommissioning and Remediation Projects<sup>175</sup>**

<b>State</b>	<b>Site</b>	<b>Historic Mission</b>	<b>Nuclear/Radioactive Facility Decommissioning</b>	<b>Release Site Remediation</b>
California	Energy Technology Engineering Center	Research, Development & Testing	1	10
	Lawrence Livermore National Lab -Site 300	Defense, Research, Development & Testing		1
	Stanford Linear Accelerator Center	Research, Development & Testing		3
Idaho	Idaho National Laboratory/Idaho Operations	Defense, Research, Development & Testing	76	109
Illinois	Argonne National Lab – East/Chicago Ops	Research, Development & Testing	9	0
Kentucky	Paducah Gaseous Diffusion Plant	Enrichment	40	114
New Mexico	Los Alamos National Lab/Albuquerque Ops	Defense, Research, Development & Testing	1	712
	Sandia National Laboratories-New Mexico	Defense, Research, Development & Testing	0	2
Multiple States (NV, AK, NM, CO, MS)	Nevada Test Site and off-site test locations	Defense (Weapons Testing)		1100
New York	Brookhaven National Laboratory	Research, Development & Testing	2	1
	Separations Process Research Unit	Research, Development & Testing	4	6
	West Valley Demonstration Project	Commercial Reprocessing		21
Ohio	Portsmouth Gaseous Diffusion Plant	Enrichment	33	1
South Carolina	Savannah River Site	Defense	212	176
Tennessee	Oak Ridge Reservation	Defense, Research, Development, & Testing	63	290
Texas	Pantex Plant	Defense	0	36
Washington	Hanford Site	Defense	471	1470
<b>TOTAL</b>			<b>912</b>	<b>4052</b>

<sup>175</sup>Source: *Office of Environmental Management FY 2009 Congressional Budget*. Reflects remaining decommissioning and remediation projects as of end of 2007.

### Annex D-5 Formerly Utilized Sites Remedial Action Program Sites

State	Site	Status
Connecticut	CE Site, Windsor	Ongoing Remediation
Illinois	Madison, Madison	Remediation Complete / Site Transferred
Indiana	Joslyn Steel, Fort Wayne	Currently Under Site Investigation
Iowa	Iowa Army Ammunition Plant, Middletown	Remedial Investigation
Maryland	W.R. Grace & Company, Curtis Bay/Baltimore	Remedial Investigation
Massachusetts	Shpack Landfill, Norton	Ongoing Remediation
Missouri	Latty Avenue Properties, Hazelwood	Ongoing Remediation
	St. Louis Airport Site, St. Louis	Remediation Complete
	St. Louis Airport Site Vicinity Properties, St. Louis	Ongoing Remediation
	St. Louis Downtown Site, St. Louis	Ongoing Remediation
New Jersey	Maywood Site, Maywood	Ongoing Remediation
	Wayne Site, Wayne	Remediation Complete/ Site Transferred
	Middlesex Sampling Plant, Middlesex	Ongoing Remediation
	DuPont Chamber Works, Deepwater	Ongoing Remediation
New York	Niagara Falls Storage Site, Lewiston	Ongoing Remediation
	Ashland 1, Tonawanda	Remediation Complete
	Ashland 2, Tonawanda	Remediation Complete
	Linde, Tonawanda	Ongoing Remediation
	Guterl Steel, Buffalo	Remedial Investigation
	Seaway Industrial Park, Tonawanda	Ongoing Remediation
	Colonie Site, Colonie	Ongoing Remediation
	Sylvania Corning Plant, Hicksville	Remedial Investigation
	Bliss & Laughlin	Remediation Complete / Site Transferred
Ohio	Luckey Site, Luckey	Ongoing Remediation
	Painesville Site, Painesville	Ongoing Remediation
	Dayton Unit I, Dayton	PA/SI Inventory completed – concluded that no further action under FUSRAP is warranted. Decision made not to include into FUSRAP.
	Dayton Unit III, Dayton	
	Dayton Unit IV, Dayton	
	Dayton Warehouse, Dayton	
	Harshaw Chemical	Remedial Investigation
Pennsylvania	Shallow Land Disposal Area, Parks Township	Ongoing Remediation
	Superior Steel, Canegie	Remedial Investigation to be scheduled

Source: U.S. Army Corps of Engineers, *Formerly Utilized Sites Remedial Action Program Historical Listing and Site Status*, March 2008.

**Annex D-6 Decommissioning Of Complex Licensed Materials Sites<sup>176</sup>**

<b>NRC Regulated Sites</b>			
<b>State</b>	<b>Installation</b>	<b>Location</b>	<b>Decommissioning Status<sup>177</sup></b>
Connecticut	ABB Prospects	Windsor	Estimated closure in 12/2010, under unrestricted release.
	UNC Naval Products (a.k.a. United Nuclear)	New Haven	Estimated closure in 9/2009, under unrestricted release.
Indiana	Jefferson Proving Ground (Department of the Army)	Madison	Estimate closure after 12/2013 under restricted release.
Michigan	AAR Manufacturing Group, Inc.	Livonia	Estimated closure in 9/2011, under restricted release.
	NWI Breckenridge	Breckenridge	Estimated closure to be determined
Missouri	ABC Labs	Columbia	Estimated closure to be determined
	Mallinckrodt Chemical Inc.	St. Louis	Estimated closure in 5/2010, under unrestricted release.
	Westinghouse Electric Corp. (Hematite Facility)	Jefferson City	Estimated closure in 6/2011 under unrestricted release.
New Jersey	Shieldalloy Metallurgical Corp	Newfield	Estimated closure in 9/2012 under restricted release.
	Stepan Chemical Company	Maywood	Estimated closure in 9/2010 under unrestricted release.
New York	West Valley	West Valley	Estimated closure to be determined.
Oklahoma	FMRI (Fansteel), Inc.	Muskogee	Estimate closure after 12/2023, under unrestricted release.
	Kerr-McGee – Cimarron	Cimarron	Estimated closure after 1/2017 under unrestricted release.
Pennsylvania	Babcock & Wilcox SLDA <sup>178</sup>	Vandergrift	Estimated closure in 3/2013, under restricted release.
<b>Agreement State Regulated Sites</b>			
<b>State</b>	<b>Installation</b>	<b>Location</b>	<b>Decommissioning Status</b>
California	General Atomics	San Diego	December 2009
	Excel Research Services, Inc.	Fresno	September 2008
	Halaco	Oxnard	EPA Superfund Site
	The Boeing Company	Simi Valley	Ongoing
	Providencia Holdings, Inc.	Burbank	Ongoing
	Chevron Mining, Inc. (Formerly Molycorp)	Mountain Pass	Ongoing
	AeroJet Ordnance Co.	Chino	September 2008
	Isotope Specialties	Burbank	Ongoing
	Magnesium Alloy Products	Compton	December 2008
Colorado	Colorado School of Mines Research Institute Table Mtn.	Golden	2008
	Colorado School of Mines Research Institute Creekside	Golden	2009
	Redhill Forest-domestic water treatment	Fairplay	TBD
	Clean Harbors	Deer Trail	TBD

<sup>176</sup>Source: NUREG 1814

<sup>177</sup> Unspecified closure dates pending resolution of site-specific regulatory provisions; e.g., financial assurance, waste management arrangements, etc.

<sup>178</sup> NRC retains regulatory authority, including decommissioning phase, at sites having special nuclear material in quantities sufficient to form a critical mass.

Agreement State Regulated Sites			
State	Installation	Location	Decommissioning Status
Florida	Mosaic Fertilizer, LLC	Nichols	January 2009
	U.S. Agri-Chemicals Corp.	Fort Meade	July 2010
	C.F. Industries, Inc.	Bartow	October 2008
	Mosaic Fertilizer, LLC	Mulberry	July 2009
	HRK Holdings, LLC (Formerly Piney Point Phosphates, Inc.)	Palmetto	2010
Illinois	Spectrulite Consortium	Madison	June 2008
	Chicago Magnesium	Blue Island	November 2010
	TRONOX-Rare Earths & Thorium (Formerly Kerr-McGee)	West Chicago	2012
Kansas	Air Capitol Dial	Wichita	TBD
	Aircraft Instrument & Development/ RC Allen Instruments	Wichita	TBD
	Century Instruments Corporation	Wichita	TBD
	Instrument and Flight Research	Wichita	TBD
	Kelley Instruments, Inc.	Wichita	TBD
	Instrument, Inc.	Wichita	TBD
Massachusetts	Shpack Landfill	Norton	September 2009
	BASF (Formerly Engelhard Corporation)	Plainville	TBD
	Starmet Corp. ( Formerly Nuclear Metals)	Concord	TBD
	Wyman Gordon Co.	North Grafton	TBD
	Texas Instruments	Attleboro	TBD
	Norton/St. Gobain	Worcester	TBD
Nebraska	University of Nebraska Disposal Trenches	Mead	2008
Ohio	Metallurg Vanadium Corp. (Formerly Shieldalloy Metallurgical Corp.)	Cambridge	January 2009
	Ineos USA, LLC (Formerly BP Chemical)	Lima	December 2020
	Advance Medical Systems, Inc.	Cleveland	December 2010
Oregon	TDY Industries Dba Wah Chang	Albany	TBD
	PCC Structurals, Inc.	Portland	TBD
Pennsylvania	Curtis-Wright	Cheswick	December 2008
	Karnish Instruments	Lock Haven	TBD
	Molycorp, Inc. (Washington)	Washington	June 2008
	Superbolt (formerly Superior Steel)	Carnegie	TBD
	Quehanna (formerly Permagrain Products, Inc.)	Karthaus	December 2008
	Safety Light Corporation	Bloomsburg	Transferred to EPA-TBD
	Strube Incorporated	Lancaster County	TBD
	Westinghouse Electric Corp. (Waltz Mill)	Madison	TBD
Whittaker Corporation	Greenville	TBD December 2008	

### Annex D-7 NRC-Licensed Power and Demonstration Reactors Under Decommissioning

Facility	Location	Reactor Type	Power	D&D Status
<b>Commercial Power Reactors</b>				
Humboldt Bay 3	Eureka, CA	Boiling Light-Water Reactor	63 Mwe	SAFSTOR
Rancho Seco	Sacramento, CA	Pressurized Light-Water Reactor	913 Mwe	DECON
San Onofre – Unit 1	San Clemente, CA	Pressurized Light-Water Reactor	436 Mwe	DECON
Vallecitos BWR	Sunol, CA	Boiling Light-Water Reactor	5 MW	SAFSTOR
Millstone – Unit 1	Waterford, CT	Boiling Light-Water Reactor	660 Mwe	SAFSTOR
Dresden – Unit 1	Dresden, IL	Boiling Light-Water Reactor	200 Mwe	SAFSTOR
Zion – Unit 1	Waukegan, IL	Pressurized Light-Water Reactor	1,040 Mwe	SAFSTOR
Zion – Unit 2	Waukegan, IL	Pressurized Light-Water Reactor	1,040 Mwe	SAFSTOR
Fermi – Unit 1	Newport, MI	Liquid Metal Fast Breeder Reactor	61 Mwe	SAFSTOR
Indian Point – Unit 1	Buchanan, NY	Pressurized Light-Water Reactor	257 Mwe	SAFSTOR
Peach Bottom – Unit 1	Delta, PA	High Temperature Gas Reactor	40 Mwe	SAFSTOR
Three Mile Island – Unit 2	Harrisburg, PA	Pressurized Light-Water Reactor	792 Mwe	Monitored SAFSTOR
La Crosse	La Crosse, WI	Boiling Light-Water Reactor	50 Mwe	SAFSTOR
Nuclear Ship Savannah	Newport News, VA	Pressurized Light-Water Reactor	80 MW	SAFSTOR
<b>Research and Test Reactors</b>				
General Atomics	San Diego, CA	TRIGA Mark F	1,500 kW	DECON Approved
General Atomics	San Diego, CA	TRIGA Mark I	250 kW	DECON Approved
University of Illinois	Urbana, IL	TRIGA	1,500 kW	DECON Approved
National Aeronautics and Space Administration	Cleveland, OH	Tank	60 MW	DECON Approved
National Aeronautics and Space Administration	Cleveland, OH	Mockup	100 kW	DECON Approved
Ford Nuclear Reactor	Ann Arbor, MI	Pool	2 MW	DECON Approved
General Electric Co.	Sunol, CA	GETR (Tank)	50 MW	SAFSTOR Possesion Only
General Electric Co.	Alameda, CA	VESR	2 MW	SAFSTOR Possesion Only
Veterans Administration	Omaha, NE	TRIGA-Mark I	20 kW	DECON Amendment
University of Buffalo	Buffalo, NY	Pool	2 MW	SAFSTOR Possesion Only

## Annex E-1 NRC Guidance

NRC provides guidance on acceptable methods for meeting its regulatory requirements. Guidance documents, such as regulatory guides or staff technical positions, are not a substitute for regulations. Compliance with guidance is not required. Methods, analysis, and solutions different from guidance are also acceptable if they demonstrate meeting actual regulatory requirements. Some examples of guidance include:

### HLW Management

NUREG-1804, Revision 2, *Yucca Mountain Review Plan* (Final Report) July 2003.

NUREG-1494, *Staff Technical Position on Consideration of Fault Displacement Hazards in Geologic Repository Design*, March 1994.

NUREG-1563, *Branch Technical Position on the Use of Expert Elicitation in the HLW Program*, issued November 1996.

### LLW Management

Regulatory Guide 4.20, *Constraint on Releases of Airborne Radioactive Materials to The Environment For Licensees Other Than Power Reactors*.

Regulatory Guide 4.18, *Standard Format and Content of Environmental Reports for Near-Surface Disposal of Radioactive Waste*, June 1983.

NUREG-1200, *Standard Review Plan for the Review of a License Application for a Low-Level Radioactive Waste Disposal Facility*, Revision 3, April 1994.

NUREG-1300, *Environmental Standard Review Plan for the Review of a License Application for a Low-Level Radioactive Waste Disposal Facility*.

NUREG-1199, *Standard Format and Content of a License Application for a Low-Level Radioactive Waste Disposal Facility*, Revision 2. January 1991.

NUREG-1241, *Licensing of Alternative Methods of Disposal of Low-Level Radioactive Waste*.

NUREG-1573, *A Performance Assessment Methodology for Low-Level Radioactive Waste Disposal Facilities*.

Regulatory Guide 4.19, *Guidance for Selecting Sites for Near-Surface Disposal of Low-Level Radioactive Waste*, August 1988.

### Uranium Recovery

NUREG-1724, *Standard Review Plan for the Review of DOE Plans for Achieving Regulatory Compliance at Sites with Contaminated Ground Water Under Title I of the Uranium Mill Tailings Radiation Control Act: Draft Report for Comment*, June 2000.

NUREG-1623, *Design of Erosion Protection for Long-Term Stabilization*, September 2002.

NUREG-1620, Rev. 1. *Standard Review Plan for the Review of a Reclamation Plan for Mill Tailings Sites Under Title II of the Uranium Mill Tailings Radiation Control Act*, June 2003.

NUREG-1569, *Standard Review Plan for In Situ Leach Uranium Extraction License Applications*, June 2003.

*Uranium Mill In Situ Leach Uranium Recovery, and 11e.(2) Byproduct Material Disposal Site Decommissioning Inspection*, (Procedure 87654), March 2002.

### Decommissioning

NUREG/CR-5512, *Residual Radioactive Contamination From Decommissioning Parameter Analysis*, April 1996.

NUREG-1556, *Consolidated Guidance About Nuclear Materials*, Vol 1-20.

NUREG-1700, *Standard Review Plan for Evaluating Nuclear Power Reactor License Termination Plans*, April 2003.

Regulatory Guide 1.184, *Decommissioning Of Nuclear Power Reactors*, July 2000.

Regulatory Guide 1.185, *Standard Format and Content for Post-shutdown Decommissioning Activities*, July 2000.

NRC Regulatory Issue Summary 2002-02, *Lessons Learned Related to Recently Submitted Decommissioning Plans and License Termination Plans*, January 2002.

NRC Regulatory Issue Summary 2004-08 *Results Of The License Termination Rule Analysis*, May 28, 2004.

NUREG-1575, *Multi-Agency Radiation Survey and Site Investigation Manual*, Revision 1. August 2001.

NUREG-1757, *Consolidated Decommissioning Guidance*, Volumes 1-3.

*Action Plan to Ensure Timely Cleanup of Site Decommissioning Management Plan Sites*, 57 FR 13389 April 1992.

Regulatory Guide 1.179, *Standard Format and Content of License Termination Plans for Nuclear Power Reactors*, January 1999.

NUREG/CR-6477, *Revised Analyses of Decommissioning Reference -Non-Fuel-Cycle Facilities*, December 2002.



## Annex E-1 NRC Guidance

NUREG-1628, <i>Staff Responses to Frequently Asked Questions Concerning Decommissioning of Nuclear Power Reactors</i> , June 2000.
NUREG-0586, <i>Generic Environmental Impact Statement on Decommissioning of Nuclear Facilities</i> (also NUREG-0586, Supplement 1, Vols. 1 & 2).
NUREG-1496, <i>Generic Environmental Impact Statement in Support of Rulemaking on Radiological Criteria for license Termination of NRC-Licensed Nuclear Facilities</i> , Vols. 1-3, U.S. Nuclear Regulatory Commission, Washington, D.C.
<b>Spent Fuel Management</b>
NUREG-1536, <i>Standard Review Plan for Dry Cask Storage Systems</i> .
NUREG-1567, <i>Standard Review Plan for Spent Fuel Dry Storage Facilities</i> .
NUREG-1609, <i>Standard Review Plan for Transportation Packages for Radioactive Material</i> , Supplement 1, <i>Standard Review Plan for Transportation Packages for MOX-Radioactive Material</i> and Supplement 2, <i>Standard Review Plan for Transportation Packages for Irradiated Tritium-Producing Burnable Absorber Rods (TPBARs)</i> .
NUREG-1617, <i>Standard Review Plan for Transportation Packages for Spent Nuclear Fuel</i> , Supplement 1, <i>Standard Review Plan for Transportation Packages for MOX Spent Nuclear</i> .
Interim Staff Guidance:
ISG-1, <i>Damaged Fuel</i>
ISG-2, <i>Fuel Retrievability</i>
ISG-3, <i>Post Accident Recovery and Compliance with 10 CFR 72.122(l)</i>
ISG-4, <i>Cask Closure Weld Inspections</i>
ISG-5, <i>Confinement Evaluation</i>
ISG-6, <i>Establishing Minimum Initial Enrichment for the Bounding Design Basis Fuel Assembly(s)</i>
ISG-7, <i>Potential Generic Issue Concerning Cask Heat Transfer in a Transportation Accident</i>
ISG-8, <i>Burnup Credit in the Criticality Safety Analyses of PWR Spent Fuel in Transport and Storage Casks</i>
ISG-9, <i>Storage of Components Associated with Fuel Assemblies</i>
ISG-10, <i>Alternatives to the ASME Code</i>
ISG-11, <i>Cladding Considerations for the Transportation and Storage of Spent Fuel</i>
ISG-12, <i>Buckling of Irradiated Fuel Under Bottom End Drop Conditions</i>
ISG-13, <i>Real Individual</i>
ISG-14, <i>Supplemental Shielding</i>
ISG-15, <i>Materials Evaluation</i>
ISG-16, <i>Emergency Planning</i>
ISG-17, <i>Interim Storage of Greater Than Class C Waste</i>
ISG-18, <i>The Design/Qualification of Final Closure Welds on Austenitic Stainless Steel Canisters as Confinement Boundary for Spent Fuel Storage and Containment Boundary for Spent Fuel Transportation</i>
ISG-21, <i>Use of Computational Modeling Software</i>
ISG-22, <i>Potential Rod Splitting Due to Exposure to an Oxidizing Atmosphere During Short-Term Cask Loading Operations in LWR or Other Uranium Oxide Based Fuel</i>
Regulatory Guide 1.13, <i>Spent Fuel Storage Facility Design Basis</i> , Rev. 2, March 2007.
Regulatory Guide 3.44, <i>Standard Format and Content for the Safety Analysis Report for an Independent Spent Fuel Storage Installation (Water-Basin Type)</i> , Rev.2, January 1989.
Regulatory Guide 3.48, <i>Standard Format and Content for the Safety Analysis Report for an Independent Spent Fuel Storage Installation or Monitored Retrievable Storage Installation (Dry Storage)</i> , Rev. 1, August 1989.
Regulatory Guide 3.49, <i>Design of an Independent Spent Fuel Storage Installation (Water-Basin Type)</i> , December 1981.
Regulatory Guide 3.50, <i>Standard Format and Content for a License Application To Store Spent Fuel and High-Level Radioactive Waste</i> (Draft FP 907-4 published 3/1981) Rev. 1. September 1989.
Regulatory Guide 3.53, <i>Applicability of Existing Regulatory Guides to the Design and Operation of an Independent Spent Fuel Storage Installation</i> , July 1982.
Regulatory Guide 3.54, <i>Spent Fuel Heat Generation in an Independent Spent Fuel Storage Installation</i> , Rev.1. January 1999.

## Annex E-1 NRC Guidance

Regulatory Guide 3.60, <i>Design of an Independent Spent Fuel Storage Installation (Dry Storage)</i> , March 1987.
Regulatory Guide 3.61, <i>Standard Format and Content for a Topical Safety Analysis Report for a Spent Fuel Dry Storage Cask</i> , February 1989.
Regulatory Guide 3.62, <i>Standard Format and Content for the Safety Analysis Report for Onsite Storage of Spent Fuel Storage Casks</i> , February 1989.
Regulatory Guide 3.72, <i>Guidance for Implementation of 10 CFR 72.48, Changes, Tests, and Experiments</i> , March 2001
Regulatory Guide 4.21, <i>Minimization of Contamination and Radioactive Waste Generation: Life-Cycle Planning</i> , June 2008.
Regulatory Guide 7.4, <i>Leakage Tests on Packages for Shipment of Radioactive Materials</i> , June 1975.
Regulatory Guide 7.5, <i>Administrative Guide for Obtaining Exemptions from Certain NRC Requirements over Radioactive Material Shipments</i> , Rev. O-R, May 1977.
Regulatory Guide 7.6, <i>Design Criteria for the Structural Analysis of Shipping Cask Containment Vessels</i> , Rev. 1, March 1978.
Regulatory Guide 7.7, <i>Packaging and Transportation of Radioactively Contaminated Biological Materials</i> , June 1974.
Regulatory Guide 7.8, <i>Load Combinations for the Structural Analysis of Shipping Casks for Radioactive Material</i> , Rev 1, March 1989.
Regulatory Guide 7.9, <i>Standard Format and Content of Part 71 Applications for Approval of Packages for Radioactive Material</i> , Rev. 2, March 2005.
Regulatory Guide 7.10, <i>Establishing Quality Assurance Programs for Packaging Used in Transport of Radioactive Material</i> , Rev. 2, March 2005.
Regulatory Guide 7.11, <i>Fracture Toughness Criteria of Base Material for Ferritic Steel Shipping Cask Containment Vessels with a Maximum Wall Thickness of 4 Inches (0.1 m)</i> , June 1991.
Regulatory Guide 7.12, <i>Fracture Toughness Criteria of Base Material for Ferritic Steel Shipping Cask Containment Vessels with a Wall Thickness Greater than 4 Inches (0.1 m) But Not Exceeding 12 Inches (0.3 m)</i> , June 1991.

## Annex F-1 Qualification Requirements for NRC Staff and Procedures Related to Spent Fuel or Radioactive Waste Inspection

Manual Chapter	Title
0111	Region I Monitoring Activities for the DOE West Valley Demonstration Project
0312	Technical Assistance for Radiation Safety Inspections at Nuclear Fuel Cycle Facilities and Materials Licensees' Sites
1246A06	<i>NMSS Spent Fuel Project Office Qualification Journal</i>
1246A08	<i>Training Requirements for Division of Waste Management Inspectors and License Reviewers</i>
1246A09	<i>Training Requirements for Decommissioning Inspectors</i>
1246A10	<i>Training Requirements for Division of Waste Management Decommissioning Project Managers &amp; Technical Reviewers</i>
1246A12	<i>Training Requirements For Uranium Recovery Inspector</i>
1246A13	<i>Training Requirements For Uranium Recovery License Reviewer</i>
1246A14	<i>Training Requirements For HLW Repository Inspector</i>
1246A15	<i>Training Requirements For HLW Repository License Technical Reviewers</i>
1246B08	<i>Division Of Waste Management Inspectors and License Reviewers Qualification Journal</i>
1246B09	<i>Decommissioning Inspector Qualification Journal</i>
1246B10	<i>Division of Waste Management Decommissioning Project Managers &amp; Technical Reviewers Qualification Journal</i>
1246B12	<i>Uranium Recovery Inspector NRC Inspector Journal Qualification Journal</i>
1246B13	<i>Uranium Recovery Project Manager/Technical Reviewer NRC Project Manager/Technical Reviewer Qualification Journal</i>
1246B14	<i>HLW Repository Inspector NRC Inspector Qualification Journal</i>
1246B15	<i>HLW Repository License Technical Reviewer NRC Technical Reviewer Qualification Journal</i>
2401	<i>Near-Surface Low-Level Radioactive Waste Disposal Facility Inspection Program</i>
2561	<i>Decommissioning Power Reactor Inspection Program</i>
2602	<i>Decommissioning Inspection Program For Fuel Cycle Facilities And Materials Licensees</i>
2620	<i>On-Site Construction Reviews Of Remedial Action At Inactive Uranium Mill Tailing Sites (Title I, Uranium Mill Tailings Radiation Control Act)</i>
2641	<i>In Situ Leach Facilities Inspection Program</i>
2690	<i>Inspection Program For Dry Storage Of Spent Reactor Fuel At Independent Spent Fuel Storage Installations &amp; For Part 71 Transportation Packaging</i>
2801	<i>Uranium Mill 11e.(2) Byproduct Material Disposal Site And Facility Inspection Program</i>

## Annex F-2 Radiation Protection Guidance

Federal guidance is a set of guidelines developed by EPA for use by Federal and state agencies responsible for protecting the public from the harmful effects of radiation. Prior to the formation of EPA in 1970, Federal guidance was the responsibility of the Federal Radiation Council. Guidance on radiation protection from EPA comes in two forms:

- Federal Guidance Recommendations, which are signed by the President and usually reflected in Federal regulations for radiation protection of workers or the general public, and
- Federal Guidance Technical Reports, which help standardize radiation dose and risk assessment methodologies.

### Federal Guidance Recommendations

Radiation Protection Guidance for Federal Agencies, Federal Radiation Council 25 FR 9057 September 26, 1961.	This guidance provides recommendations for population groups exposed to environmental sources of radiation. It provides Radiation Protection Guides; guidance on general principles of control applicable to all environmental radionuclides; and specific guidance in connection with exposure of population groups to radium-226, iodine-131, strontium-90, and strontium-89.
Radiation Protection Guidance for Federal Agencies, Federal Radiation Council 25 FR 4402 May 18, 1960.	This guidance provides a general framework for radiation protection and general principles of radiation control based on the annual intake of radioactive materials. These recommendations provide the basis for the control and regulation of radiation exposure during normal peacetime operations. Numerical values for the Radiation Protection Guides, designed to limit the exposure of the whole body and certain organs, are provided.
Radiation Protection Guidance to Federal Agencies for Occupational Exposure, U.S. Environmental Protection Agency 52 FR 2822 January 27, 1987.	This guidance provides general principles, and specifies the numerical primary guides for limiting worker exposure. It applies to all workers who are exposed to radiation in the course of their work, either as employees of institutions and companies subject to Federal regulation or as Federal employees.
Radiation Protection Guidance to Federal Agencies for Diagnostic X-rays, U.S. Environmental Protection Agency 43 FR 4377 February 1, 1978.	This guidance provides recommendations to reduce radiation exposure from the use of diagnostic x-rays. These recommendations, transmitted to the President jointly by EPA and the Department of Health, Education and Welfare were based on two guiding principles: avoidance of unnecessary prescription of x-rays, and use of good technique to minimize radiation exposure.
Underground Mining of Uranium Ore, Federal Radiation Council 34 FR 576 January 15, 1969 35 FR 245 December 18, 1970.	This guidance sets forth recommendations for radiation protection activities as they apply to the underground mining of uranium ore. EPA subsequently reviewed these recommendations and concluded no modification was necessary.

### Federal Guidance Technical Reports

Technical reports summarize current scientific and technical information for radiation dose and risk assessments. Examples of technical reports are:

Background Material for the Development of Radiation Protection Standards, Federal Radiation Council, July 1964.	This guidance provides background material used in the development of guidance for Federal agencies for (1) planning protective actions to reduce potential doses to the population from radioactive fission products which may contaminate food, and (2) doses at which implementation of protective actions may be appropriate.
The Radioactivity Concentration Guides, EPA 520/1-84-010, December 1984.	This guidance provides numerical values for the concentrations of radioactivity in air and water, corresponding to the limiting annual doses recommended for workers in the 1960 <i>Federal Guidance Document, Radiation Protection Guidance for Federal Agencies</i> , and
Cancer Risk Coefficients for Environmental Exposure to Radionuclides, EPA 402-R-99-001, September 1999.	This guidance provides methods and data for estimating risks due to both internal and external radionuclide exposures. The information presented in this report is for use in assessing risks from radionuclide exposure in a variety of applications ranging from environmental impact analyses of specific sites to the general analyses supporting rulemaking.

### Annex F-3 Emergency Event Categories

The vast majority of events reported to NRC are routine and do not require activation of its incident response program. See *How We Respond to an Emergency*<sup>179</sup> for information on how NRC responds to threatening public health and safety emergencies. NRC-licensed facilities have various classes of emergencies. The following are emergency classifications for nuclear material and fuel cycle facility licensees. Some nuclear materials licensees may also use the **Unusual Event** classification to notify officials of events of lower safety significance, although not required by NRC regulations.

Category	Description
Alert	An alert is declared if events occur, are in progress, or have occurred that could lead to a release of radioactive material(s), but the release is not expected to require a response by an offsite response organization to protect people offsite.
Site Area Emergency	A site emergency involves events that may occur, are in progress, or have occurred that could lead to a significant release of radioactive material(s), and the release could require a response by offsite response organization to protect people offsite.

### Annex F-4 NRC Participation in Emergency Exercises During 2005-2007

Date	Facility/Activity/ Exercise Title	Participants
4/4-10/2005	TOPOFF Ardent Sentry	Interagency, Connecticut, New Jersey, Florida
4/20/2005	Framatome	NRC Region II, Washington
5/24/2005	Honeywell	NRC HQ, NRC Region III, Illinois
6/20-24/2005	Pinnacle	Interagency
1/25/2006	Materials Exercise	NRC HQ, NRC Region III
4/17-21/2006	Forward Challenge	NRC HQ and Regions
5/8-18/2006	Ardent Sentry	Multi-Agency
3/9/2007	COOP Tabletop	Tabletop
5/16-17/2007	Pinnacle/Ardent Sentry	Multi-Agency
9/25/2007	Multi-Agency Tabletop	Multi Agency
10/15-24/2007	TOPOFF	Multi Agency

<sup>179</sup><http://www.nrc.gov/what-we-do/emerg-preparedness/respond-to-emergency.html>

## Annex F-5 Requirements for Notifying NRC of Emergency and Non-Emergency Events<sup>180</sup>

### Specific requirements for NRC-licensed radioactive materials<sup>181</sup>

Standards for Protection Against Radiation (10 CFR Part 20):

- §20.2201 Reports of theft or loss of licensed material.
- §20.2202 Notification of incidents.
- §20.2203 Reports of exposures, radiation levels, and concentrations of radioactive material exceeding the constraints or limits.

Domestic Licensing of Byproduct Material (10 CFR 30.50) Reporting requirements.

Domestic Licensing of Source Material (10 CFR 40.60) Reporting requirements.

Domestic Licensing of Production and Utilization Facilities (10 CFR Part 50):

- §50.72 Immediate notification requirements for operating nuclear power reactors.
- §50.73 Licensee event reporting system.

Domestic Licensing of Special Nuclear Material (10 CFR Part 70):

- §70.50 Reporting requirements.
- §70.52 Reports of accidental criticality or loss or theft or attempted theft of special nuclear material.
- §70.74 Additional reporting requirements (Appendix A -Reportable Safety Events)

Licensing Requirements for Independent Storage of Spent Fuel and High-Level Radioactive Waste (10 CFR Part 72):

- §72.74 Reports of accidental criticality or loss of special nuclear material.
- §72.75 Reporting requirements for specific events and condition.

Material Control and Accounting of Special Nuclear Material (10 CFR 74.11 Reports of loss or theft or attempted theft or unauthorized production of special nuclear material).

Certification of Gaseous Diffusion Plants (10 CFR 76.120 Reporting requirements.

### Examples of non-reactor incident reports

NUREG-1405, *Inadvertent Shipment of a Radiographic Source from Korea to Amersham Corporation, Burlington, Massachusetts* (Publication Date: May 1990).

NUREG-1450, *Potential Criticality Accident at the General Electric Nuclear Fuel and Component Manufacturing Facility, May 29, 1991* (Publication Date: August 1991).

NUREG-1480, *Loss of an Iridium-192 Source and Therapy Misadministration at Indiana Regional Cancer Center Indiana, Pennsylvania on November 16, 1992* (Publication Date: February 1993).

NUREG-1535, *Ingestion of Phosphorus-32 at Massachusetts Institute of Technology, Cambridge, Massachusetts, Identified on August 19, 1995* (Publication Date: December 1995).

### Links to Additional Information on Response to Incidents

FEMA State Offices and Agencies of Emergency Management: <http://www.fema.gov/about/contact/statedr.shtm>

Federal Emergency Management Agency (FEMA): <http://www.fema.gov/>

Department of Energy (DOE): <http://energy.gov>

U.S. Environmental Protection Agency (EPA): <http://www.epa.gov/>

Department of Agriculture (USDA): <http://www.usda.gov/>

Department of Health and Human Services (HHS): <http://www.hhs.gov/>

Department of State (DOS): <http://www.state.gov/>

Federal Bureau of Investigation (FBI): <http://www.fbi.gov/>

<sup>180</sup>For more information on NRC Incident Investigation Program, see NRC Management Directive 8.3, NRC Incident Investigation Program accessible at: <http://www.nrc.gov/what-we-do/emerg-preparedness/faq/ml031250592.pdf>

<sup>181</sup>There are equivalent requirements for the relevant Agreement States.

## **Annex F-6. Emergency Preparedness and Planning at Diverse Waste Management and Disposal Facilities**

### **Geological Repository for Spent Fuel and HLW**

NRC requires DOE develop and be prepared to implement a plan to cope with radiological accidents occurring at the geologic repository operations area, at any time before permanent closure and decontamination or decontamination and dismantlement of surface facilities (10 CFR 63.161). The emergency plan must be based on the criteria of 10 CFR 72.32(b). These criteria require an Emergency Plan including:

- Facility description,
- Types of accidents,
- Classification of accidents,
- Detection of accidents,
- Mitigation of consequences,
- Assessment of releases,
- Responsibilities,
- Notification and coordination,
- Information to be communicated,
- Training,
- Safe condition,
- Exercises,
- Hazardous chemicals,
- Comments on Plan,
- Off-site assistance, and
- Arrangements made for providing information to the public.

### **LLW Facilities**

An applicant must provide a description of the radiation safety program for control and monitoring of radioactive effluents as part of the radiation safety program required for a specific license to dispose of LLW. The objective is to ensure compliance with performance requirements in the regulation (10 CFR 61.41), occupational radiation exposure to comply with 10 CFR Part 20 and control contamination of personnel, vehicles, equipment, buildings, and the disposal site. Both routine operations and accidents are addressed. The program description includes procedures, instrumentation, facilities, and equipment. The regulations specific to emergency planning are in 10 CFR 61.12(k) and §61.13.

The applicant for a near surface disposal site for low-level radioactive waste (LLW) must propose an emergency response plan. NRC or Agreement States will review this plan to determine whether the licensee would be able to respond to all credible radiological accidents and emergencies consistent with the proposed method of operations. The criteria to assess such a demonstration are in NUREG-1200, *Standard Review Plan for the Review of a license application for a LLW Disposal Facility*. These criteria include:

- Compliance with 44 CFR Part 350, *Review and Approval of State and Local Radiological Emergency Plans and Preparedness*;
- Establishing plans to respond to all credible radiological accidents and emergencies consistent with the proposed method of operations; and

- Demonstrating the maximum off-site releases for the most credible accident consistent with the projected source term will yield an off-site dose equivalent of less than 0.1 mSv (0.01 rem) to the whole body and 0.5 mSv (0.05 rem) to the lungs.

The applicant must develop emergency procedures, including interaction with local and State authorities, as well as notification of affected populations where the maximum potential off-site releases yield greater dose equivalents. Such procedures must be developed with knowledge, participation and cooperation of these authorities and affected populations.

The applicant presents this analysis in the safety analysis report provided with the license application; the Standard Format and Content of a license application for a Low-Level Radioactive Waste Disposal Facility (NUREG-1199, Revision 2) and the Environmental Standard Review Plan for the review of a license application for a Low-Level Radioactive Waste Disposal Facility (NUREG-1300) provide guidance for prospective applicants. The accident scenarios addressed include:

- Waste spillage;
- Fire and/or chemical reactions;
- Transportation accidents;
- Nuclear criticality; and
- On-site effects of off-site accidents.

### **Uranium Recovery Waste Management Facilities**

Accidental releases and emergency preparedness are addressed as part of the operational phase of uranium recovery. The perpetual disposal design is required to be robust and not need active maintenance to assure isolation and stability from 200 to 1000 years. Operational considerations for emergency planning during the operational phase are addressed in 10 CFR 40.31(j)(3).

Credible incidents at a uranium milling facility and at a uranium mine would result in minor exposures. The analysis documented in NUREG-1140 estimates a 1-mSv (0.1-rem) effective dose equivalent under the most adverse weather conditions for a fire at a uranium mill. Fires and uranium mill tailings releases (dam failures, pipeline ruptures, etc...) from the late 1950s through the early 1980s are documented in NUREG-1140.

### **Decommissioning**

NRC does not identify a critical radiological accident for decommissioning. Licensees are required to analyze their particular facility and determine the appropriate health and safety measures necessary to maintain worker and public doses within NRC limits. The health and safety plan is provided to NRC as part of the decommissioning or license termination plan (DP or LTP). NRC reviews the plan as part of its review and approval of the DP or LTP.

### **Role of Inspection and Emergency Preparedness for Decommissioning**

Existing Inspection Manual Chapters, Inspection Procedures and Temporary Instructions are applicable and recommended for use in inspection of sites undergoing decommissioning. IP 8850 can be used for emergency preparedness inspection at facilities undergoing decommissioning.



The objectives of this procedure are to ensure the licensee or certificate holder:

- Is complying with regulations and license/certificate requirements related to the processing, control, release, and reporting of information to the NRC of radioactive liquid and airborne effluents;
- Is implementing a program to ensure that releases of radioactivity to the environment provide minimal impact on the environment and the public; and
- Maintains adequate management controls for the radiological effluent control and environmental program.

Additional implementation guidance is further detailed in the IP.<sup>182</sup>

---

<sup>182</sup>This document can be downloaded from: <http://www.nrc.gov/reading-rm/doc-collections/insp-manual/inspection-procedure/ip88050.pdf>

## LIST OF ACRONYMS AND ABBREVIATIONS

Acronym	Name
AEC	Atomic Energy Commission
ACNW&M	Advisory Committee on Nuclear Waste and Materials-now merged into the ACRS
ACRS	Advisory Committee on Reactor Safeguards
ADAMS	Agency-wide Documents Access and Management System (NRC)
AEA	Atomic Energy Act of 1954
ALARA	As Low as Reasonably Achievable
ANSI	American National Standards Institute
ANS-8	American Nuclear Society Standards Subcommittee 8
ASLB	Atomic Safety Licensing Board
CCA	Compliance Certification Application
CERCLA	Comprehensive Environmental Response, Compensation, and Liability Act
CFR	Code of Federal Regulations
CNS	Convention on Nuclear Safety
COE	U.S. Army, Corps of Engineers
CoC	Certificate of Compliance
CRCPD	Conference of Radiation Control Program Directors
CSE	Cognizant Systems Engineers
D&D	Decontamination & Decommissioning
DHS	Department of Homeland Security
DNDO	Domestic Nuclear Detection Office (DHS)
DNFSB	U.S. Defense Nuclear Facilities Safety Board
DOE	U.S. Department of Energy
DOE-HSS	DOE Office of Health, Safety and Security
DOL	U.S. Department of Labor
DoS	U.S. Department of State
DOT	U.S. Department of Transportation
DP	Decommissioning Plan
DU	Depleted uranium
EIS	Environmental Impact Statement
EnPA	Energy Policy Act of 1992
EPacT05	Energy Policy Act of 2005
ERAMS	Environmental Radiation Ambient Monitoring System
ERDA	Energy Research and Development Administration
EPA	U.S. Environmental Protection Agency
FEMA	Federal Emergency Management Agency
FTE	Full Time Equivalent
FUSRAP	Formerly Utilized Sites Remedial Action Program
GNEP	Global Nuclear Energy Partnership
GTCC	Greater-than-Class C Low-Level Waste
GTRI	Global Threat Reduction Initiative

Acronym	Name
HEU	Highly-Enriched Uranium
HEW	Department of Health, Education and Welfare
LEU	Low-Enriched Uranium
HLW	High-Level Waste
IAEA	International Atomic Energy Agency
ICRP	International Commission on Radiation Protection
IMPEP	Integrated Materials Performance Evaluation Program
INES	International Nuclear Event Scale
INL	Idaho National Laboratory
ISFSI	Independent Spent Fuel Storage Installation
ISL	<i>In situ</i> Leach
ISMS	Integrated Safety Management System
LANL	Los Alamos National Laboratory
LAW	Low-Activity Waste
LILW	Low and Intermediate Level Waste
LILW-LL	Low and Intermediate Level Waste – Long Lived
LILW-SL	Low and Intermediate Level Waste – Short Lived
LLW	Low-Level Waste
LLRWPA	Low-Level Radioactive Waste Policy Act of 1980
LSN	Licensing Support Network
LLRWPAA	Low-Level Radioactive Waste Policy Amendments Act of 1985
LTP	License Termination Plan
LTR	License Termination Rule
LTSP	Long-Term Surveillance Plan
MED	Manhattan Engineering District
MOU	Memorandum of Understanding
MOX	Mixed Oxide
MPRSA	Marine Protection, Research, and Sanctuaries Act of 1972
MRB	Management Review Board
MRS	Monitored Retrievable Storage
MT	Metric Tons
MTHM	Metric Tons Heavy Metal
NAS	National Academy of Sciences
NA	Not Applicable or Not Available
NCRP	National Council on Radiation Protection And Measurements
NDAA	National Defense Authorization Act for Fiscal Year 2005
NEA	Nuclear Energy Agency (Organisation for Economic Co-operation and Development)
NEPA	National Environmental Policy Act
NESHAPs	National Emission Standards for Hazardous Air Pollutants
NMED	State of New Mexico Environmental Department
NNSA	National Nuclear Security Administration
NORM	Naturally Occurring Radioactive Materials

Acronym	Name
NOV	Notice of Violation
NPL	National Priorities List for CERCLA
NRC	U.S. Nuclear Regulatory Commission
NSTS	National Source Tracking System
NTS	Noncompliance Tracking System
NUREG	NRC technical Report designating Nuclear Regulatory Commission
NWF	Nuclear Waste Fund
NWPA	Nuclear Waste Policy Act of 1982
NWPAA	Nuclear Waste Policy Amendments Act of 1987
NWTRB	U.S. Nuclear Waste Technical Review Board
OCRWM	Office of Civilian Radioactive Waste Management (DOE)
ORNL	Oak Ridge National Laboratory
ORPS	Occurrence Reporting and Processing System
PAAA	Price-Anderson Amendments Act of 1988
PFS	Private Fuel Storage, LLC
PSDAR	Post-Shutdown Decommissioning Activity Report
QA	Quality Assurance
RCRA	Resource Conservation and Recovery Act of 1976
RH	Remote-handled
RMEI	Reasonably Maximally Exposed Individual
S/CI	Suspect/Counterfeit Items
SDMP	Site Decommissioning Management Plan
SDP	Significance Determination Process
SFP	Spent Fuel Pool
SSAB	Site-Specific Advisory Boards
SSC	Systems, Structures, and Components
Sv	Sievert
TAD	Transport, aging, and disposal
TEDEs	Total Effective Dose Equivalents
TENORM	Technologically Enhanced NORM
TMI-2	Three-Mile Island Unit-2
TRU	Transuranic
TSPA	Total System Performance Assessment
U.S.	United States of America
UMTRCA	Uranium Mill Tailings Radiation Control Act
WIPP	Waste Isolation Pilot Plant
WIPP LWA	Waste Isolation Pilot Plant Land Withdrawal Act of 1992
WP	Waste Package

## ADDITIONAL REFERENCES

Numerous references to laws, regulations, regulatory guides, standards, and DOE orders are provided throughout this report and are not repeated here (see Table E-1, Table E-2, Annex E-1, Annex F-7, and Annex F-2) for brevity. Internet web sites are also provided in Table A-2. The following additional resources were used:

- International Atomic Energy Agency, *Classification of Radioactive Waste; A Safety Guide*, Safety Series No. 111-G-1.1., IAEA , Vienna, Austria, 1994.
- International Atomic Energy Agency, *Establishing a National System for Radioactive Waste Management*, Safety Series No 111-S-1.1, Vienna, Austria, 1995.
- International Atomic Energy Agency, Guidelines Regarding the Form and Structure of National Reports: *Joint Convention on the Safety of Spent Fuel Management and on the Safety of Radioactive Waste Management*, Vienna, Austria, December 13, 2002.
- International Atomic Energy Agency, *Joint Convention on the Safety of Spent Fuel Management and on the Safety of Radioactive Waste Management*, INFCIRC/516, Vienna, Austria, December 24, 1997.
- Oregon Office of Energy, *Naval Nuclear Reactor Compartment Shipments on the Columbia River*, Oregon, USA, February 2003.  
<http://www.oregon.gov/ENERGY/NUCSAF/docs/brochure.pdf>
- U.S. Nuclear Regulatory Commission, NUREG/BR-0216, *Radioactive Waste: Production, Storage, Disposal*, Revision 2. Washington DC, USA, May, 2002.
- U.S. Nuclear Regulatory Commission, NUREG-1650, *The United States of America Fourth National Report for the Convention on Nuclear Safety*, Revision 2, Washington DC, USA, September 2007.
- U.S. Nuclear Regulatory Commission, Information Digest 2002 Edition (NUREG 1350, Vol. 14). Washington, DC, USA, 2002.
- U.S. Department of Energy, Energy Information Administration, Report No. DOE/EIA-0592, *Decommissioning of U.S. Uranium Production Facilities*, Washington, DC, USA, February 1995.
- U.S. Department of Energy, Energy Information Administration Form RW-859, *Spent Fuel Data* Washington, DC, USA, 1998.
- U.S. Department of Energy, *DOE's Current, Planned, and Projected Dry Storage Facilities Table*, Washington, DC, USA, January 2003.
- U.S. Department of Energy, DOE-EM-0630, *Annual Report of Waste Generation and Pollution Prevention Progress 2001*, Washington DC, June 2002.  
<http://tis.eh.doe.gov/p2/wastemin/2001ar.pdf>.

- U.S. Department of Energy Environmental Management Stream Disposition Data (IPABS, 8/28/01).
- U.S. Department of Energy Grand Junction Office, internet web site.
- U.S. Department of Energy, *Low-Level Waste Disposal Capacity Report*, (2000).
- U.S. Department of Energy, DOE/EIS-0250, *Final Environmental Impact Statement for a Geologic Repository for the Disposal of Spent Nuclear Fuel and High-Level Radioactive Waste at Yucca Mountain, Nye County, Nevada*, Washington DC, February 2002.
- U.S. Department of Energy National Spent Fuel Database (Version 4.2.0, March 2002).
- U.S. Environmental Protection Agency, *Fact Sheet on Ocean Dumping of Radioactive Waste Materials*, Office of Radiation Programs, Washington, DC, 1980 (web site).
- U.S. Environmental Protection Agency, *Data from Studies of Previous Radioactive Waste Disposal in Massachusetts Bay*, Office of Radiation Programs, Washington, DC, 1984 (web site).
- U.S. Environmental Protection Agency, EPA 402-R-05-007, *Technologically Enhanced Naturally-Occurring Radioactive Materials from Uranium Mining, Volume 1: Mining and Reclamation Background*, Radiation Protection Division, Washington, DC, June 2006 updated June 2007.
- U.S. Environmental Protection Agency, EPA 402-R-05-008, *Technologically Enhanced Naturally-Occurring Radioactive Materials from Uranium Mining, Volume 2: Investigation of Potential Health, Geographic, and Environmental Issues of Abandoned Uranium Mines*, Radiation Protection Division, Washington, DC, April 2008.
- U.S. Environmental Protection Agency, EPA 402-R-05-009, *Uranium Location Database Compilation*, Radiation Protection Division, Washington, DC, August 2006.