



Orano Federal Services

Title: Design and Prototype Fabrication of Railcars for Transport of High-Level Radioactive Material; Phase 3 – Prototype Fabrication and Delivery

Doc./Rev.: EIR-3021970-000

Project: 00225.03.0050 - DOE Atlas Project

Page 3 of 59

Design and Prototype Fabrication of Railcars for Transport of High-Level Radioactive Material

Phase 3: Prototype Fabrication and Delivery

DE-NE0008390

Prepared by: Orano Federal Services LLC





DISCLAIMERS

This report was prepared as an account of work sponsored by an agency of the United States Government. Neither the United States Government nor any agency thereof, nor any of their employees, nor any of their contractors, subcontractors, or their employees, makes any warranty, express or implied, or assumes any legal liability or responsibility for the accuracy, completeness, or usefulness of any information, apparatus, product, or process disclosed, or represents that its use would not infringe privately owned rights. Reference herein to any specific commercial product, process, or service by trade name, trademark, manufacturer, or otherwise, does not necessarily constitute or imply its endorsement, recommendation, or favoring by the United States Government or any agency, contractor, or subcontractor thereof. The views and opinions of authors expressed herein do not necessarily state or reflect those of the United States Government or any agency, contractor, or subcontractor thereof.

This is a technical report that does not take into account the contractual limitations under the Standard Contract for Disposal of Spent Nuclear Fuel and/or High-Level Radioactive Waste (Standard Contract) (10 CFR Part 961). For example, under the provisions of the Standard Contract, DOE does not consider spent nuclear fuel in multi-assembly canisters to be an acceptable waste form, absent a mutually agreed to contract amendment. To the extent discussions or recommendations in this report conflict with the provisions of the Standard Contract, the Standard Contract provisions prevail.



Table of Contents

Table with 2 columns: Section Name and Page. Includes sections like REVISION HISTORY, LIST OF TABLES, EXECUTIVE SUMMARY, INTRODUCTION, GENERAL INFORMATION, and ATLAS PROTOTYPE RAILCAR.



4.2.4 Bill of Materials and Vendors 38

4.2.5 Special Processes 38

4.2.6 Atlas Railcar Operations and Maintenance Information..... 38

4.3 Impacts to Atlas Railcar AAR EEC Notice to Proceed..... 39

5.0 BUFFER PROTOTYPE RAILCAR 40

5.1 Buffer Railcar Overview 40

5.2 Buffer Railcar Deliverables 41

5.2.1 Buffer Railcar As-Built Design Changes 41

5.2.2 Buffer Railcar As-Built Fabrication Drawings 41

5.2.3 Buffer Railcar Inspection Documentation..... 43

5.2.4 Bill of Materials and Vendors 49

5.2.5 Special Processes 49

5.2.6 Buffer Railcar Operations and Maintenance Information 49

5.3 Impacts to Buffer Railcar AAR EEC Notice to Proceed 50

6.0 TEST LOAD DESIGNS 51

6.1 Empty Railcar Ballast Load Description and Design..... 51

6.2 Minimum Test Load and Cradle Description and Design..... 52

6.3 Maximum Test Load and Cradle Description and Design..... 53

7.0 OTHER INFORMATION..... 55

7.1 Changes to Conceptual Cradle Designs as a Result of Phase 3..... 55

7.1.1 HI-STAR 60 (Family 1) Conceptual Cradle Design Revision..... 55

7.2 Changes to General Loading Procedures as a Result of Phase 3 55

7.2.1 Cleaning and Rust Prevention of Cradle Attachment Interface Pin Blocks..... 55

7.2.2 Angle of Tie Downs Used During Loading/Unloading..... 56

8.0 REFERENCES..... 57

Appendix A – Atlas Railcar As-Built fabrication Drawings

Appendix B – Atlas Railcar Inspection Reports

Appendix C – Atlas Railcar Bill of Materials and Vendors

Appendix D – Revised Atlas Railcar Operation and Maintenance Information Manual

Appendix E – Buffer Railcar As-Built Fabrication Drawings

Appendix F – Buffer Railcar Inspection Reports

Appendix G – Buffer Railcar Bill of Materials and Vendors



Orano Federal Services

Title: Design and Prototype Fabrication of Railcars for Transport of High-Level Radioactive Material; Phase 3 – Prototype Fabrication and Delivery

Doc./Rev.: EIR-3021970-000

Project: 00225.03.0050, DOE Atlas Project

Page 7 of 59

Appendix H – Revised Buffer Railcar Operation and Maintenance Information Manual

Appendix I – Test and Ballast Load Fabrication Designs

Appendix J – Revised Family 1 Conceptual Cradle Design

Appendix K – Revised General Loading Procedures



List of Tables

	Page
TABLE 2-1: PHASE 3 PROJECT PARTICIPANTS AND ROLES	14
TABLE 2-2: PHASE 3 DELIVERABLES AND STATUS	15
TABLE 3-1: NOMINAL CHARACTERISTICS OF SPENT NUCLEAR FUEL TRANSPORTATION CASKS	21

List of Figures

	Page
FIGURE 4.1 – ATLAS RAILCAR.....	25
FIGURE 5.1 – BUFFER RAILCAR.....	40
FIGURE 6.1 – BALLAST LOAD.....	50
FIGURE 6.2 – THE CENTRAL ASSEMBLY AND MINIMUM TEST LOADS.....	51
FIGURE 6.3 – THE MINIMUM TEST LOAD AND MINIMUM TEST LOAD CRADLE.....	52
FIGURE 6.4 – THE MAXIMUM TEST LOAD, MAXIMUM TEST LOAD CRADLE AND END STOPS.....	53



List of Acronyms

AAR	Association of American Railroads
ASME	American Society of Mechanical Engineers
AWS	American Welding Society
BOM	Bill of Materials
CA	Conditionally Approved
cg	Center of Gravity
CoC	Certificate of Compliance
COR	Contracting Officer's Representative
CWI	Certified Weld Inspector
DBRD	Design Basis Requirements Document
DOE	Department of Energy
DTF	Data Transmittal Form
EEC	Equipment Engineering Committee
EIR	Engineering Information Record
FRA	Federal Railroad Administration
FS	Orano Federal Services LLC
HLRM	High Level Radioactive Material
MSRP	Manual of Standards and Recommended Practices
NCR	Nonconformance Report
NDE	Non-Destructive Examination
NRC	Nuclear Regulatory Commission
ORNL	Oak Ridge National Laboratory
PQAP	Project Quality Assurance Plan
PQR	Procedure Qualification Record
QA	Quality Assurance
QAPD	Quality Assurance Program Description
QASP	Quality Assurance Surveillance Plan
REV	Rail Escort Vehicle
SDSR	Supplier Document Submittal Review form
SME	Subject Matter Expert



SNR	Supplier Nonconformance Review
SOW	Statement of Work
TTC	Transportation Technology Center
TTCI	Transportation Technology Center, Inc.
WPS	Welding Procedure Specification



1.0 EXECUTIVE SUMMARY

The United States Department of Energy (DOE) is preparing for future large-scale transport of spent nuclear fuel and high-level radioactive waste, which are collectively defined as High-Level Radioactive Material (HLRM) by the Association of American Railroads (AAR). A part of this preparation includes designing railcars to be used for the transport of HLRM.

The DOE Contract DE-NE0008390 titled "Design and Prototype Fabrication of Railcars for Transport of High-Level Radioactive Material" was awarded to AREVA Federal Services, LLC (now known as Orano Federal Services LLC) in August 2015. Prototype railcars are to include both a cask railcar to haul HLRM casks (hereafter, the deliverable cask railcar is specifically referred to as "Atlas") and two buffer railcars used for spacing between the train engine and Atlas railcars, the Atlas and escort railcars, and for weight distribution between Atlas railcars, as deemed necessary.

In addition to the development of design and fabrication requirements, the key contract requirement is for the railcars to be approved by the AAR as compliant with AAR Standard S-2043. This standard prescribes the performance guidelines that must be met by trains carrying HLRM. These guidelines optimize vehicle performance and incorporate the best available technology to minimize the chances of derailment.

The first three phases of this project, governed by DOE Contract Number DE-NE0008390, are summarized below:

- 1) Phase 1 includes (completed):
 - a) The mobilization and conceptual design of an Atlas railcar and its associated buffer railcar;
 - b) The conceptual design of cask cradles for securement of HLRM casks on the Atlas railcar;
 - c) General Loading Procedures for cask-to-cradle-to-railcar, and;
 - d) The railcar's functional, design, operational, and maintenance requirements.
- 2) Phase 2 includes (completed):
 - a) The submission of the preliminary design packages of the Atlas and buffer railcars designed to meet the AAR Standard S-2043 guidelines;
 - b) The delivery of the preliminary design data package and dynamic modeling input and output data files to DOE, and;
 - c) The subsequent receipt from the AAR of a notice to "proceed with the test phase" which allows the prototype railcars to be built in accordance with Section 3.2.1 of S-2043.
- 3) Phase 3 includes (completed):
 - a) The fabrication and delivery of one Atlas and two buffer prototype railcars;
 - b) The delivery of an as-built design package including drawings, inspection reports, and Bill of Materials (BOM) for both the Atlas and buffer railcars;
 - c) Operation and maintenance manuals including maintenance intervals for both the Atlas and buffer railcars;



- d) Final design information necessary for the fabrication of test loads, cradles and end stops necessary for future testing of the Atlas railcar.

This report titled “Design and Prototype Fabrication of Railcars for Transport of High-Level Radioactive Material, Phase 3: Prototype Fabrication and Delivery” compiles the work that was completed during Phase 3. This report includes a summary of the results in meeting Phase 3 contract objectives including fabrication of the prototype railcars, an as-built data package for the fabricated railcars, test load and ballast load fabrication designs, and copies of Phase 3 deliverables in the appendices.



2.0 INTRODUCTION

This report provides fabrication and maintenance information for the Atlas and buffer railcars in compliance with DOE contract DE-NE0008390 and the AAR's safety standard S-2043 [1]. The railcars also comply with the recent AAR Standard S-2044, Safety Appliances for Freight Cars, dated 2017 [2].

This section provides background information regarding this report's content and layout, an introduction to the project's team members and their roles, a status summary of Phase 3 deliverables, and a brief chronological outline of Phase 3 activities.

2.1 Report Content and Layout

This report specifically summarizes the efforts and accomplishments of Phase 3 of the High-Level Radioactive Material (HLRM) prototype Atlas and buffer railcars project. Sections 2.0 through 6.0 provide introductory and project status information, a description of the Atlas and buffer railcars, required as-built fabrication data packages for the railcars, test load and empty Atlas railcar ballast load designs, and a review of previously submitted design or railcar loading information that changed as a result of the railcar's fabrication. Specifically, the sections include the following:

- Sections 2.2 – 2.4 provide project background, a summary of the project team members, deliverable requirements and status, and a chronological order of the project's Phase 3 major activities.
- Section 3.0 provides a summary of the project's regulatory requirements, a summary of project challenges, and information regarding railcar delivery.
- Section 4.0 provides an overview of the Atlas railcar, a review of its contract deliverables, and information regarding impacts to the AAR EEC Notice to Proceed to Testing as a result of fabrication.
- Section 5.0 provides an overview of the buffer railcar, a review of its contract deliverables, and information regarding impacts to the AAR EEC Notice to Proceed to Testing as a result of fabrication.
- Section 6.0 provides descriptions of the minimum and maximum test load, the test loads' cradles and end stops, the Atlas empty railcar ballast load, and their designs for fabrication.
- Section 7.0 provides information regarding the changes in previously submitted project documentation as a result of fabrication related to a change to the HI-STAR 60 conceptual cradle design, and changes to the general loading procedures.
- Section 8.0 provides a listing of references used in this report.

Appendices for this report include the actual deliverables and conceptual design supporting documents, which were submitted to and approved by the DOE. These will be utilized in the future detailed design of the Atlas railcar's cask cradles and production railcars. Enclosed appendices include:

- Appendix A – Atlas Railcar As-Built fabrication Drawings
- Appendix B – Atlas Railcar Inspection Reports
- Appendix C – Atlas Railcar Bill of Materials and Vendors
- Appendix D – Revised Atlas Railcar Operation and Maintenance Information Manual
- Appendix E – Buffer Railcar As-Built Fabrication Drawings
- Appendix F – Buffer Railcar Inspection Reports
- Appendix G – Buffer Railcar Bill of Materials and Vendors



- Appendix H – Revised Buffer Railcar Operation and Maintenance Information Manual
- Appendix I – Test and Ballast Load Fabrication Designs
- Appendix J – Revised Family 1 Conceptual Cradle Design
- Appendix K – Revised General Loading Procedures

Note that the drawings and calculations included in the appendices are provided as images as they have been formally issued to the DOE.

2.2 Project Team Members and Their Roles

Orano Federal Services, LLC (FS) has primary responsibility for the project and provides project management and oversight and integration of team members. FS engineering subject matter experts (SMEs) provided design of the test and Atlas empty railcar ballast loads and provided oversight of fabrication quality assurance activities. Kasgro Rail Corporation, the designer of the Atlas and buffer railcars, provided fabrication of the prototype Atlas and buffer railcars.

Table 2-1 provides a listing of primary project participants performing independently managed tasks along with their defined roles.

TABLE 2-1: PHASE 3 PROJECT PARTICIPANTS AND ROLES

Participant	Primary Role
Orano Federal Services LLC	Project integrator and manager with overall responsibility for contract execution Oversight of engineering and Quality Assurance (QA) processes for entire project team Generation of modular minimum and maximum test load, test load cradles, test load end stops, and Atlas empty railcar ballast load Final report generation and publication As-built data package publication
Kasgro Rail Corporation	Fabrication of Atlas and buffer prototype railcars Generation of Atlas and buffer railcars as-built data package Delivery of completed railcars to TTC, Pueblo, CO

Throughout this report, specific reference to a company name will refer specifically to that company. The use of “Team” refers to all or a portion of the above listed companies based on assignments or as defined in current discussions.

2.3 Deliverable Requirements and Status

All Phase 3 contract deliverables have been submitted to the DOE and approved. A listing of Phase 3 deliverables and their status is included in Table 2-2. All Phase 3 deliverables have been approved by the DOE.



TABLE 2-2: PHASE 3 DELIVERABLES AND STATUS

Description	Accomplishment Expected	Approval Status
Fabrication Documents	a) As-built drawings and inspection reports; b) List of all procured parts required for fabrication including cut sheets, part numbers, specifications, vendors, etc.; c) Final design information necessary to fabricate the simulated cradle and cask loads needed for testing of the cask car as determined in the design analysis and simulations; d) Operations & Maintenance Manuals, and; e) Estimate of how long the railcar can operate between maintenance intervals as well as over the useful life of the railcar.	Approved
Prototype Railcars	a) One Atlas cask railcar b) Two buffer railcars	Approved

2.4 Chronological Outline

The following summarizes the major Phase 3 activities performed in completing the fabrication and inspection of the Atlas and buffer railcars, and the completion of the Phase 3 as-built data package:

- The Team determined that as the Atlas railcar is similar in design to the U.S. Navy’s M-290 cask railcar in its materials and utilized components, the Team would proceed at risk to:
 - Mobilize for fabrication;
 - Order long-lead materials (defined as steel formed shapes, center pin assemblies, brake systems, cushioning/coupler systems and components, Safety Monitoring System(SMS) units);
 - Order long-lead components (defined as wheel sets, Atlas trucks and spring sets, and buffer railcar trucks, dampers and spring sets).

This decision occurred during the September through October 2017 time period starting immediately after the initial submission of the Phase 2 S-2043 design package and modeling results to the AAR EEC for evaluation.

- A kickoff with the Team occurred on October 18, 2017 which reviewed the project’s schedule, deliverables, responsibilities and contract requirements.
- A Fabrication/Construction Readiness Review (FCRR) also occurred between FS and Kasgro on October 18, 2017. As a result successfully completing the FCRR, Kasgro was released to



Title: Design and Prototype Fabrication of Railcars for Transport of High-Level Radioactive Material; Phase 3 – Prototype Fabrication and Delivery

Doc./Rev.: EIR-3021970-000

Project: 00225.03.0050 - DOE Atlas Project

Page 16 of 59

procure all Phase 3 fabrication materials, long-lead materials and components, and to start mobilization on October 26, 2017. Procurement and mobilization activities were complete by November 10, 2017.

- Once procurement and mobilization activities were completed, Kasgro was released for all fabrication activities on November 20, 2017 pending receipt of a notice to proceed to testing for the prototype railcars from the AAR EEC.
- The design of minimum and maximum test loads, test load cradles and end stops, and the Atlas empty car ballast loads started in February 2018 with designs accepted by the DOE COR on July 23, 2018.
- After a review of the Team's AAR S-2043 submission for the minimum, maximum and empty loads for the cask and buffer railcar designs and dynamic modeling results, the AAR EEC requested specific modeling regimes on the remaining 17 payloads for the Atlas railcar in November 2017.
- The Team received a notification to proceed to testing for both the Atlas and buffer railcars from the AAR EEC on February 2, 2018.
- Fabrication of the prototype railcars started immediately after the AAR EEC's notification to proceed to testing was received with the initial cutting of steel plates in February 2018.
- The Atlas and buffer wheel sets were received, inspected and accepted by March 21, 2018.
- Long lead material receipt, inspection and acceptance was completed as below:
 - Formed steel shapes completed in July 2018;
 - Center pin assemblies completed in April 2018;
 - DB 60II air brake systems completed in March 2018;
 - Cushioning/coupler systems and components completed in April 2018;
 - Safety Monitoring System (SMS) components completed receipt and physical inspection in July 2018. Note: only a physical inspection could occur until the SMS were installed and tested on the railcars by Lat-Lon on February 15, 2019;
- The receipt, inspection and acceptance of the fabrication materials started in November 2017 and was completed, inspected and accepted with all material inventory records submitted by August 9, 2018.
- Truck assemblies completed receipt, inspection and acceptance by September 11, 2018 and completed receipt, inspection and acceptance of all procured materials.
- Fabrication, inspection and testing of the railcars completed in February 2019 with the following major activities:
 - Buffer railcars:
 - Frame and structural welding started in March 2018 and completed in June 2018;
 - Required ballast deck plates completed weld installation in August 2018;
 - Final assembly of the railcar concluded in September 2018;
 - Grit blasting, painting and stenciling of the railcars completed in September 2018;
 - Air brake system installation and testing occurred in September 2018;
 - The axle and load balance test occurred successfully in October 2018;
 - FRA S-2044 [2] inspection and approval occurred on October 30, 2018;
 - AAR witnessed static car brake test occurred successfully in November – December 2018 and single car air brake testing occurred successfully on



- February 11-12, 2019;
- SMS installation and testing occurred on February 13-15, 2019;
- Kasgro's New Car Inspection process and acceptance completed February 19, 2019.
- Atlas railcar:
 - Frame and structural welding started in April 2018 and completed in September 2018;
 - The jack-lug proof test was successfully performed in late August 2018;
 - Final assembly of the railcar concluded in January 2019 with the final inspection of the cradle and end stop attachment pin blocks and cradle sheer blocks;
 - Grit blasting, painting and stenciling of the railcars completed in February 2019;
 - Air brake system installation started in October 2018 and completed with successful testing in February 2019;
 - The axle and load balance test occurred in January 2019;
 - FRA S-2044 [2] inspection of the Atlas design drawings occurred in January 2019, and the inspection and acceptance occurred February 12, 2019;
 - AAR witnessed static car and single car air brake testing successfully occurred February 11-12, 2019;
 - SMS installation and testing occurred in February 13-15, 2019;
 - Kasgro's New Car Inspection process and acceptance completed February 19, 2019;
 - During the last week of January 2019, Kasgro was notified by Amsted Rail that the truck bolster's spring retention bosses were not properly welded to the Atlas railcar's bolsters; new truck bolsters with properly welded spring retention bosses replaced the incorrectly welded truck bolsters with Amsted and Kasgro completing disassembly/re-assembly of the Atlas railcar's trucks and Atlas railcar by March 1, 2019 (See Section 3.3.4 for detailed information).
- The prototype Atlas and buffer railcars were presented to the DOE COR on February 20, 2019.
- The buffer railcars completed delivery to the AAR's Technology Testing Center in Pueblo, CO on April 15, 2019 and the Atlas railcar was delivered on March 28, 2019.
- The As-Built Data Package, Phase 3 report, the as-built data package and other document deliverables were transmitted to the DOE COR on March 20, 2019.



3.0 GENERAL INFORMATION

This section provides a summary of the AAR EEC approval process and results, background information regarding both external and internal regulatory requirements, a description of utilized cask information data, and a brief listing of challenges addressed during Phase 3 fabrication activities.

3.1 Changes in AAR Requirements During Phase 3

No changes occurred in the design or as-built condition of the Atlas and buffer railcars that changes the bounding conditions, physical properties, measurements, characteristics or dynamic modeling results, etc. utilized in the AAR EEC S-2043 review and issuance of the notices to proceed to testing. As a result, no additional S-2043 evaluations of the prototype railcars as a result of fabrication are required before the start of single-car testing.

3.2 Regulatory Requirements and Specifications

The following subsections provide information related to the regulatory requirements that the HLRM prototype railcars were fabricated under.

3.2.1 Railroad Transportation Requirements

The Atlas and buffer railcar's fabrication must comply with AAR's *Manual of Standards and Recommended Practices* [3], including Standard S-2043, *Performance Specification for Trains Used to Carry High-Level Radioactive Material* [1].

The cask and buffer railcar designer and the prototype railcar fabricator must be approved to the AAR's *Manual of Standards and Recommended Practices*, Section J – Quality Assurance M-1003 (2014) [4].

Railcar fabrication must meet AAR released standard S-2044, *Safety Appliance Requirements for Freight Cars*. This standard has been incorporated into the design of the Atlas and buffer railcars [2] and is reflected in the fabricated prototype railcars.

3.2.2 Other DOE Requirements

The contract states that the cask and buffer railcars are to comply with other applicable standards as specified in the Oak Ridge National Laboratory (ORNL) report, *Cask Railcar System Requirements Document* [5]. If there is any contradiction between the System Requirements Document and the contract's Statement of Work (SOW), the SOW takes precedence.

The Atlas railcar, including a cradle and a cask, and buffer car clearances must fit within AAR Plate E, except when loaded with casks that are more than 128 inches wide with impact limiters attached. Transporting casks that are more than 128 inches wide will require special route analysis that is not a part of this contracted scope of work. The requirements for Plate E are contained within AAR Standard S-2056 [33] (formerly AAR standards S-2028 [9], S-2029 [10], S-2030 [11], and S-2031 [13]). This standard is referenced in AAR Standard S-2043, Section 4.7.9.1 [12].

3.2.3 Federal Railroad Administration Approvals

The Federal Railroad Administration (FRA) promotes and regulates safety throughout the Nation's railroad industry through its Office of Railroad Safety and its eight regional offices. The FRA is responsible for implementing the requirements of Title 49 CFR, Part 231 titled *Railroad Safety Appliance Standards* [14], which provides federal standards for occupational safety for workers in the



use of railcars. The AAR Standard S-2044 [2] was created to provide a collaborative FRA/AAR standard with safety definitions and requirements common to all railcar types and includes a series of appendices with specific requirements for individual car types.

As the FRA is responsible for implementation of safety regulations, a specialty car builder such as Kasgro will submit a drawing package of a new specialty railcar design that reflects implementation of S-2044 safety appliances requirements. The drawing package is submitted to the regional FRA office for review and compliance to AAR S-2044 requirements. The first article of the new railcar is then inspected by the regional FRA office for compliance to the approved drawings before the railcar design is placed into commercial use. A letter of compliance to AAR S-2044 is provided by the FRA.

A drawing package for the buffer railcar was provided to personnel from the FRA's Region 2 office in Crum Lynne, PA, for review. After drawing package compliance was deemed by the FRA inspector, the FRA inspected the buffer railcars for compliance in October 30, 2018 and provided a letter of compliance (see Section 5.2.3.3.1 for additional information).

A drawing package for the Atlas railcar was also provided to personnel from the FRA's Region 2 office in Crum Lynne, PA, for review. After drawing package compliance was deemed by the FRA inspector, the FRA inspected the Atlas railcar for compliance February 12, 2019 and provided a letter of compliance (see Section 4.2.3.3.4 for additional information).

3.2.4 Project Quality Requirements

In the completion of the Atlas project, FS is utilizing the FS QA Program, FS-QA-PMD-001 [15], which establishes the corporate QA requirements used to implement work activities. The program and its implementing procedures are based on ASME NQA-1-2008/2009a [16] and are organized in the 18 requirements of ASME NQA-1.

The FS QA program includes the development of a tailored Project Quality Assurance Plan (PQAP). FS developed PQAP QA-3014737 [17], which identifies the project-specific requirements such as safety class, project codes, and procedures to tailor the program to meet the project requirements.

Kasgro Rail activities for the Atlas and buffer railcars are performed in accordance with Kasgro Rail's AAR M-1003-approved QA program [19]. FS' project management and engineering provide oversight to ensure contract requirements are met.

Also, incorporated into DOE contract DE-NE0008390, Part III, Attachment J-C, is the FS *Quality Assurance Surveillance Plan* (QASP) [18] – generated during the proposal phase of this project – which is incorporated into the PQAP.

These requirements apply to all phases of the project.

3.2.5 Specific Project Quality Requirements

A summary of specific project quality requirements includes:

- 1) AAR Standard S-2043, *Performance Specification for Trains Used to Carry High-Level Radioactive Material* [1]
- 2) AAR *Manual of Standards and Recommended Practices* (MSRP), Section J – Specification for Quality Assurance, Specification M-1003 [4]
- 3) FS *Quality Assurance Program Description* (QAPD), FS-QA-PMD-001 [15]



- 4) FS Project Specific QA Plan, QA-3014737, *Design and Prototype Fabrication of Atlas Railcars for HLRM* [17]
- 5) FS *Quality Assurance Surveillance Plan* as incorporated into DOE contract DE-NE0008390, Part III, Attachment J-C [18]
- 6) Kasgro Rail's *Quality Assurance Manual* for AAR Specification M-1003 [19]

These requirements are incorporated into the single PQAP for the execution of conceptual design, procedural development, report generation, preliminary design, AAR S-2043 modeling, and data submission, detail design, fabrication, and delivery of the Atlas and buffer railcars.

3.2.6 Cask Information and Data

Phase 1 conceptual cask cradle designs are to accommodate transport by the Atlas railcar of the 17 cask designs listed in Attachment A of the SOW [6]. The Atlas cask railcar was dynamically modeled for these loads during the Phase 2 preliminary design. As a result of the Phase 2 AAR EEC's evaluation of the prototype railcars' design and modeling results, a notice to proceed to testing of the railcars was received and fabrication of the prototype railcars has occurred during Phase 3. During the Phase 3 fabrication of the prototype railcars, no change has occurred to the conceptual cradles design, bounding conditions or the design, bounding conditions, and modeling results of the prototype railcars that has impacted the AAR EEC's notice to proceed to testing. For reference, Table 3-1 displays the list of casks to be transported by the Atlas railcar and their relevant physical data as provided through Contract Modification #7.



TABLE 3-1: NOMINAL CHARACTERISTICS OF SPENT NUCLEAR FUEL TRANSPORTATION CASKS

Manufacturer and Model	Length without Impact Limiters (in.)	Length with Impact Limiters (in.)	Diameter without Impact Limiters (in.)	Diameter with Impact Limiters (in.)	Empty Weight with Impact Limiters (lb.)	Loaded Weight with Impact Limiters (lb.)
NAC International						
NAC-STC	193.0	273.7	99.0	128.0	188,767-194,560	241,664-254,589
NAC-UMS UTC	209.3	273.3	92.9	124.0	178,798	248,373-255,022
MAGNATRAN	214.0	322.0	110.0	128.0	208,000	312,000
Holtec International						
HI-STAR 100	203.25	307.5	96.0	128.0	179,710	272,622-279,893
HI-STAR HB	128.0	230.8 ^a	96.0	128.0 ^a	-- ^b	187,200
HI-STAR 180	174.37	285.04	106.3	128.0	< 308,647	308,647
HI-STAR 60	158.94	274.37	75.75	128.0 ^a	< 164,000	164,000
HI-STAR 190 SL	214.4688	339.5625	106.5 ^e	128	282,746	369,049-382,746 ^f
HI-STAR 190 XL	236.9688	362.0625	106.5 ^e	128	304,369	420,769 ^f
AREVA Transnuclear						
MP187	201.5	308.0	92.5	126.75	190,200	265,100-271,300
MP197	208.0	281.25	91.5	122.0	176,710	265,100
MP197HB	210.25	271.25	97.75	126.0	179,000	303,600
TN-32B ^c	184.0	261.0 ^a	97.75	144.0 ^a	-- ^d	263,000 ^a
TN-40	183.75	261.0	99.52	144.0	-- ^d	271,500
TN-40HT	183.75	260.9	101.0	144.0	-- ^d	242,343
TN-68	197.25	271.0	98.0	144.0	< 272,000	272,000
Energy Solutions						
TS125	210.4	342.4	94.2	143.5	196,118	285,000

Source: Contract DE-NE0008390, Modification #6, Part I, Section C, Attachment A - Transport Cask Characteristics [6]

a. Estimated

b. HI-STAR HB transportation casks are already loaded so they would not be shipped empty.

c. This is the TN-32B that DOE plans to use in the High Burnup Dry Storage Cask Research and Development Project, and ship from North Anna Nuclear Power Plant. The TN-32B does not currently have a transport certificate of compliance. The dimensions and weight with impact limiters for the TN-32B are estimated.

d. TN-40 transportation casks are authorized for single use shipments and would not be shipped empty. TN-32B and TN-40HT transportation casks would be authorized for single use shipments and would not be shipped empty on an S-2043 cask car.

e. Diameter is of cask body and does not include trunnions.

f. Weights do not include the weights of any MPC spacers that may be required.



3.3 Challenges

Challenges occurring in Phase 3 of the project related to potential steel tariffs, test load design weights, end stop pin block fabrication, and improperly welded spring retention bosses on Amsted Swing-Motion trucks for the Atlas railcar. These challenges are summarized below.

3.3.1 Material Procurement and Fabrication Mobilization

Issue: In the Fall of 2017, the HLRM prototype railcars were still in Phase 2 completing the AAR's dynamic modeling review and approval in order to receive a notification to proceed to the test phase allowing fabrication. At the same time, the US executive administration was considering placing import tariffs on foreign steel supplies to the US. As a result, domestic steel pricing and delivery times were increasing dramatically with shortages reported in common domestic carbon steel availability.

Mitigation: In order to prevent cost and schedule burdens on the HLRM prototype railcar fabrication, the Team decided to procure the steel materials necessary for the HLRM prototype railcars at risk before Phase 2 was completed. As a result, the project received all steel materials and assemblies ahead of need dates and the project was not negatively impacted by the steel tariffs placed on imported steel during the late-Winter of 2018.

3.3.2 Test Load Designs

Issue: Under Phase 2, the required conceptual designs of the test and ballast loads were completed and delivered to the DOE. During the Winter of 2018, FS progressed with the Phase 3 fabrication designs of the test loads, test load cradles and end stops, and ballast load almost completing the minimum and maximum test load fabrication designs along with their respective cradles. In late February, 2018, FS learned that TTCI would not be able to lift the test loads at the TTC site during the test phases with any on-site crane and had no suitable location to build a pad for the substantial crane needed to lift the test loads unless the loads could be lifted in pieces and assembled on the railcar using TTC's on-site cranes.

Mitigation: Although FS was meeting the required scope of work for the test loads, it reevaluated its designs and developed a modular test load design. FS also completed the final conceptual design nine months ahead of the required delivery date for the test and ballast load designs in order to allow contracts for fabrication to be placed by the DOE's test phase subcontractor TTCI, thereby accelerating the actual testing of the Atlas railcar in the single and multi-car test phases.

3.3.3 End Stop Pin Block Fabrication

Issue: The placement of the stainless-steel cladding in the end stop pin blocks proved to be extremely difficult and time consuming due to the tight quarters of the internal channel of the pin blocks. Also, maintaining the cladding flatness to meet the channel opening tolerance has not proven successful due to the difficulty in placement of the cladding and meeting the machining tolerance of the very large steel bars making up the pin blocks due to stress relieving during machining. By omission of the stainless-steel cladding, the overall pin block's gap size increases from 3" +/- 0.6" to 3.25 +/- 0.6" (reference FS Drawing 3018956-000 and Kasgro Drawing 1155-41). Also, detailed ultra-sonic testing of the end stop pin blocks by TUV Rheinland indicated the possible presence of minor anomalies in the pin block steel material.

Mitigation: For the prototype Atlas railcar, Kasgro and FS processed a Kasgro Nonconformance (NC) #2 (see Section 4.2.3.1.6) allowing Kasgro to eliminate the stainless-steel cladding in the prototype



railcar pin blocks. The larger gap and resulting force on the pin have been analyzed and loads are still within margins of safety for S-2043 transportation loading.

As the presence of the stainless steel cladding is to aid in the prevention of rust over the life of the railcar, the general loading procedures were revised to include a cleaning and grease application to the internal channel of the end stop pin blocks to prevent excessive rusting (see Appendix K, *Revised General Loading Procedures*, Section 6.0).

After further inspection and measurements of the suspect anomaly inclusions in the end stop pin blocks, the anomalies were determined to be within the acceptance criteria of ASME standard SA-435, *Standard Specification for Straight-Beam Ultrasonic Examination of Steel Plates* [7], as detailed in the TUV Rheinland ultrasonic testing report.

The resolution of these issues caused a six-week delay in the Atlas railcar fabrication during the Fall of 2018.

3.3.4 Amsted Spring Retention Boss Welding

Issue: During the last week of January 2019, Amsted Rail advised Kasgro that the Atlas' Swing-Motion truck's spring retention bosses may not be correctly welded; some may be spot welded instead of seam welded and the weld undersized. The spring retention bosses are part of the assembled truck and are not in an area that can be inspected upon receipt. The spring retention bosses were inspected by Amsted personnel by use of a borescope and determined to not be welded according to the Amsted truck bolster drawing. There are 4 spring retention bosses on each side of a truck bolster for a total of 8 spring retention bosses per truck; a total of 48 spring retention bosses per Atlas railcar.

Mitigating Actions: In order to facilitate the completion and delivery of the prototype railcars, it was determined to continue the final Atlas AAR brake tests, SMS installation and final railcar inspection process as currently scheduled. Once these Kasgro activities were completed on February 22nd, Kasgro proceeded with disassembly of the Atlas railcar to remove the individual trucks and started disassembly of the Amsted trucks. Replacement truck bolsters with properly welded spring retention bosses and weld inspection data were provided by Amsted Rail. Upon receipt by Kasgro, the bolsters' spring retention bosses were inspected for proper welding to the Amsted drawing, and the welds inspected by Kasgro's certified weld inspector (TUV Rheinland) and deemed acceptable. Trucks were then reassembled with the replacement bolsters containing the correctly welded spring retention bosses; the trucks were re-assembled under truck maintenance procedures for the Amsted Swing-Motion trucks. The Atlas railcar was then re-assembled and a brake test performed by Kasgro's AAR approved brake test inspector. Documentation to substantiate the rework activities is provided in Sections B.3.4 and B.3.5 of Appendix B, Atlas Railcar Inspection Reports.

Also, Kasgro reported Amsted Rail's nonconformance weld issue to the AAR by submission of the following AAR documents:

- QA-7.1, Association of American Railroads Quality Assurance Nonconformance Report Form to report Amsted's manufacturing defect in not meeting proper weld requirements;
- QA-7.2, Association of American Railroads Quality Assurance Nonconformance Response Form to report actions Amsted took to disposition the non-conformance;
- QA-7.3, Association of American Railroads Quality Assurance Nonconformance Response Evaluation Form to report that Kasgro has evaluated Amsted's disposition response in form QA-7.2 and found it acceptable.



Orano Federal Services

Title: Design and Prototype Fabrication of Railcars for Transport of High-Level Radioactive Material; Phase 3 – Prototype Fabrication and Delivery

Doc./Rev.: EIR-3021970-000

Project: 00225.03.0050 - DOE Atlas Project

Page 24 of 59

These documents are provided in Section B.3.6 of Appendix B, Atlas Railcar Inspection Reports, to substantiate Kasgro's required AAR reporting of the issue.



4.0 ATLAS PROTOTYPE RAILCAR

This section of the Phase 3 report and its accompanying Appendix A, B, C and D provide as-built fabrication information for the Atlas cask railcar.

4.1 Atlas Railcar Overview

The Atlas railcar is designed to transport casks containing HLRM on cradles. The railcar design has twelve axles and is symmetrical end-to-end, including its railcar-to-cradle interface and end stop attachment pin blocks. The railcar is designed to meet AAR Standard S-2031 Plate E requirements [21, 26]. The basic railcar design, including its trucks, brakes and their components, and the railcar's monitoring system, is very similar to the Navy's M-290 railcar design, the only other railcar that has received conditional approval to AAR Standard S-2043 from the AAR EEC. The main difference between the two cask railcars is that the Atlas railcar is designed to carry 17 different cask payloads in removable cradles, while the M-290 railcar has a single payload and a permanently mounted cradle.

Of the 17 different cask payloads, the heaviest is the HI-STAR 190 XL. This total payload, including the fully loaded cask, impact limiters, cradle, and end stops, weighs approximately 480,000 pounds. At present, this is the upper limit of payload that the Atlas railcar can carry in compliance with AAR Standard S-2043. If any heavier cask is ever designed, then this new payload would have to be modeled and tested on the Atlas railcar to determine if the payload upper limit could be increased.

When the Atlas railcar is not carrying a payload, it will weigh only 229,000 pounds (200,000 pounds for the Atlas railcar plus 29,000 pounds for the permanently attached cradle interface and end stop pin blocks). In this configuration, it satisfies the normal freight rail requirements of AAR Standard M-1001, but it does not satisfy the requirements of AAR Standard S-2043. The Atlas railcar only needs to satisfy S-2043 when it is carrying HLRM. The lightest weight HLRM payload is estimated to be 200,000 pounds, so the Atlas railcar has been modeled and will be tested for HLRM payloads in the weight range of 200,000 pounds to 480,000 pounds. As an option, a temporary ballast weight has been developed to allow the railcar to meet S-2043 performance guidelines when carrying no HLRM; see Section 6.5 and Appendix I for additional information.

Other specific design features of the Atlas railcar are:

- Extreme Width 10'-8"
• Loading Deck Length 48'-0"
• Overall Length..... 73"-5"
• Coupled Length 78'-1 1/4"
• Number of Axles 12
• Wheel Size 36"
• Minimum Turning Radius 150 feet
• Design load limits:
o Design total railcar truck capacity (based on 71,500 lbs/axle limit)...858,000 lbs
o Design railcar empty weight (estimate based on total weight of empty railcar and permanent attachments)..... 229,000 lbs
o Design railcar interchange load limit (based on conservative 65,750 lbs/axle operational constraints)..... 789,000 lbs

- Operational load limits (as stenciled on side of railcar):
 - Gross Rail Load (GRL; based on interchange limit of 65,750 lbs/axle; AAR definition as load limit + light weight)..... 789,000 lbs
 - Light Weight Load (LT WT based on actual weight of empty railcar and permanent attachments)..... 225,700 lbs
 - Load Limit (LD LMT; an estimate based on railcar operational payload capacity which is also the largest dynamic modeled weight)..... *485,000 lbs
 - Note: Per the Field Manual of the AAR Interchange Rules, Rule 88, B.1.d.(h) [8], when structural limitation of a car is less than truck capacity, a star symbol (*) must be applied to the left of the "LD LMT" stencil. Here, the "LD LMT *485,000 lbs" is used to denote a structural and operational payload limit of the greatest dynamic modeled weight, which is a payload of a loaded HI-STAR 190 XL cask, cradle, and endstops. The railcar will be weighed during fabrication and the actual weight used in railcar markings.

FIGURE 4.1 – ATLAS RAILCAR

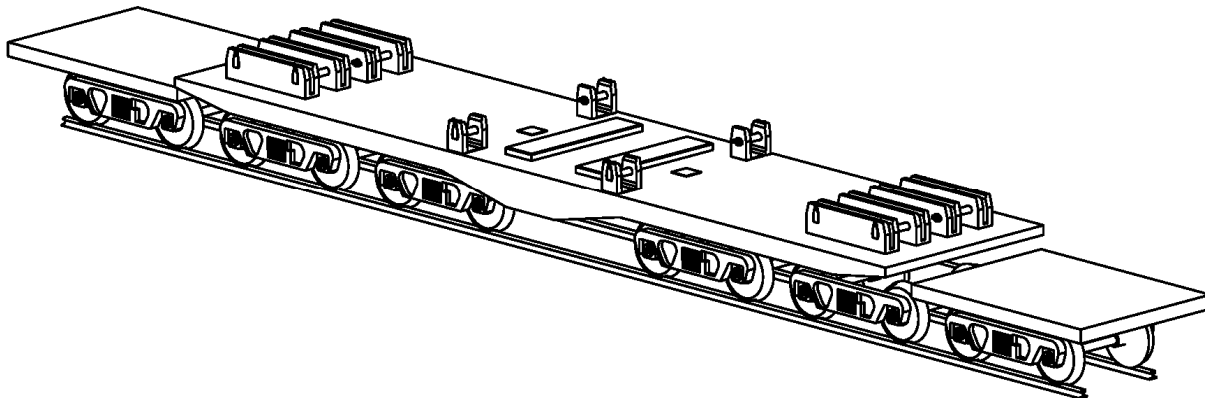

4.2 Atlas Railcar Deliverables

This section provides information regarding Phase 3 project deliverables for the Atlas railcar. These deliverables include as-built fabrication drawings, fabrication inspection reports, material and vendor information, special processes, operations and maintenance information and a description of any impacts to the AAR notice to proceed due to fabrication of the Atlas railcar.

4.2.1 Atlas Railcar As-Built Design Changes

Design changes were made to the Atlas Railcar Cradle Attachment conceptual design during fabrication of the first of a kind Atlas railcar. The changes are summarized in three main categories:

1. Changes due to pin block cladding removal – The pin block cladding requirement was removed via Kasgro NC #2 (see Section 4.2.3.1.6) and the loading procedures were updated to add additional lubrication for corrosion protection.
2. Changes due to weld shrinkage of the center four pin locations – the center four pin attachment blocks experienced shrinkage during welding. To accommodate for this, the thickness of the



cradle placement pads was slightly reduced to reestablish the required cradle interface dimension.

Some as-built dimensions deviate slightly from the conceptual cradle attachment design but are still within a usable state. These dimensions were documented in Kasgro NCs and dispositioned in an FS Supplier Nonconformance Review (SNR). Additional design verification was performed and the as-built dimensions were found to be acceptable for interface with the conceptual cradle designs; see Section 4.2.3.1.6, *Nonconformance Reports*, for additional information.

4.2.2 Atlas Railcar As-Built Fabrication Drawings

As-built fabrication drawings for the Atlas railcar, along with the associated Kasgro NCs reflect its completed fabrication state including the cradle-to-railcar attachment interface system. The included drawings are listed in Table 4-1 and are enclosed in Appendix A, *Atlas Railcar As-Built Fabrication Drawings*.

TABLE 4-1: KASGRO ATLAS RAILCAR AS-BUILT DRAWINGS

Drawing Number	Description	Revision ¹	Summary Description of Revision Change	Reference Appendix Item
1155-1	Car Body Arrangement	A	Deleted duplicate symbols	Appendix A-1
1155-2	Brake Arrangement			Appendix A-2
1155-3	Stencil Arrangement	B	Deleted paint color and railcar weights	Appendix A-3
1155-4	End Platform Arrangement			Appendix A-4
1155-5	End Platform Details			Appendix A-5
1155-6	End Platform Details			Appendix A-6
1155-7	Air Brake Schematic			Appendix A-7
1155-8	Body Bolster			Appendix A-8
1155-9	Center Plate			Appendix A-9
1155-10	Steel Details			Appendix A-10
1155-11	Steel Details	A	Revised dimension 3-76	Appendix A-11
1155-12	Steel Details			Appendix A-12
1155-13	Steel Details			Appendix A-13
1155-14	Steel Details			Appendix A-14
1155-15	Steel Details			Appendix A-15
1155-16	Steel Details			Appendix A-16
1155-17	Steel Details			Appendix A-17
1155-18	Steel Details			Appendix A-18



Title: Design and Prototype Fabrication of Railcars for Transport of High-Level Radioactive Material; Phase 3 – Prototype Fabrication and Delivery

Doc./Rev.: EIR-3021970-000

Project: 00225.03.0050 - DOE Atlas Project

1155-19	Brake Steel Details			Appendix A-19
1155-20	Brake Steel Details			Appendix A-20
1155-21	Pipe Details			Appendix A-21
1155-22	Pipe Details			Appendix A-22
1155-23	Brake Pipes			Appendix A-23
1155-24	Steel Details			Appendix A-24
1155-25	Hand Brake Details			Appendix A-25
1155-26	Hand Brake Details			Appendix A-26
1155-27	Hand Brake Details			Appendix A-27
1155-28	Hand Brake Details			Appendix A-28
1155-29	Brake Badge Plate			Appendix A-29
1155-30	Locking Center Pins			Appendix A-30
1155-31	Grab Irons			Appendix A-31
1155-32	Spring Grouping	A	Revise title block and notes	Appendix A-32
1155-33	Brake Steel Details			Appendix A-33
1155-34	Camber Diagram			Appendix A-34
1155-35	Clearance			Appendix A-35
1155-36	Steel Details			Appendix A-36
1155-37	Steel Details			Appendix A-37
1155-38	Steel Details			Appendix A-38
1155-39	Center Pin Details			Appendix A-39
1155-40	Handbrake Arrangement			Appendix A-40
1155-41	Attachment Arrangement			Appendix A-41
1155-42	Sheave Brackets			Appendix A-42
1155-43	HB (Handbrake) Steel Details			Appendix A-43
1155-44	Steps			Appendix A-44

Note: 1) The original issue of an approved drawing shows no revision level; first revision is listed as revision "A".



4.2.2.1 Cradle Attachment Drawing 3018956

The FS drawing for the Atlas railcar cradle attachment system – DWG-3018956-000, Atlas Railcar Cradle Attachment – is included as part of as-built drawing package in Appendix A.45. Drawing DWG-3018956-000 was created from the conceptual Atlas Railcar cradle attachment components drawing (DWG-3015278-002), to provide some additional detail for fabrication. Not all components of the fabricated Atlas railcar met the requirements of DWG-3018956-000 resulting in some rework and repair. The final as-built condition is documented in both DWG-3018956-000 and associated Kasgro nonconformances which were evaluated and dispositioned by FS (see Section 4.2.3.1.6).

4.2.3 Atlas Railcar Inspection Documentation

The following subsections provide information and reference evidence of the Atlas railcar's fabrication to contract requirements, specifications, standards, Kasgro procedures and drawing requirements. Fabrication and inspection documentation to support the acceptance of the Atlas railcar are presented as:

- a) Atlas Fabrication Inspection Documentation – those documents supporting Kasgro fabrication processes;
- b) Special Process Inspection Documentation – documents supporting special processes due to S-2043, AAR requirements, or critical fabrication/assembly techniques;
- c) Other Inspection Documentation – other documentation to support contractual and other non-routine requirements, and;
- d) Common Inspection Documentation – common documents supporting both the acceptance of the Atlas and buffer railcars.

In addition to the Kasgro produced inspection documentation provided in Appendix B accompanying each subsection topic, a FS Data Transmittal Form (DTF) and Supplier Document Submittal Review (SDSR) form are included reflecting a formal FS review, revision/correction if necessary by Kasgro, and approval of Kasgro provided inspection documentation.

4.2.3.1 Atlas Railcar Fabrication Inspection Documentation

The following subsections describe Kasgro fabrication and related inspection processes and the forms used to record the results of those inspections.

4.2.3.1.1 Atlas Railcar Travelers

Kasgro utilizes detailed drawings with specification and fabrication instruction callouts by major railcar assembly operation and/or component track and monitor fabrication. Fabrication travelers typically reflect a collection of the applicable drawing(s), part number and material control number lists, and inspection and heat lot records for utilized parts and subassemblies; therefore, the traveler also serves as a quality control record and quality assurance summary document. The traveler includes a listing of the assembly operators performing the fabrication operations, the operators' supervisor(s) and the applicable inspector(s). The Kasgro inspector's signature confirms that the fabricated assembly is acceptable to applicable drawing and specification requirements before it is released to the next stage of railcar assembly. Travelers are enclosed in Appendix B.1.1 that prove the occurrence of this process for the Atlas railcar. This traveler process was also observed, reviewed and approved by signature by FS QA personnel during the Atlas railcar's fabrication as shown on the enclosed travelers.



4.2.3.1.2 Burning Table Inspection Reports, Forms 9Z and 9Z-A

The Kasgro *Burning Table Inspection Report* is a form used to record acceptable large-scale steel materials parts cut by an outside contractor (Form 9Z) or as cut on the Kasgro plasma cutting (burn) table (Form 9Z-A). These forms are used to record that cut materials meet drawing requirements. Non-conforming materials are never accepted and therefore, never recorded on these inspection reports. The burning table inspection reports also have a table of sampling size listed for reference and a location for an inspector approved to the Kasgro QA requirements under AAR M-1003 to sign for acceptance of the listed plasma-cut items. FSF approved Forms 9Z and 9Z-A for the Atlas railcar are enclosed in Appendix B.1.2.

4.2.3.1.3 Car Body – Heat Identification Form, Form 44B

Kasgro Form 44B is used to record individual metal parts utilized in the fabrication of each individual railcar structure and deck. The form includes each part number, drawing number the part is required for, the heat number reflecting the raw metal plate the individual part is cut from, the quantity per car, the material the part is made from and any special testing required. The form also has a place for signature by Kasgro quality control personnel indicating acceptance. Non-conforming parts are not included as they are not accepted into an in-process railcar fabrication. FS approved forms are enclosed in Appendix B.1.3.

4.2.3.1.4 Span Bolster Heat Identification Form, Form 42

Kasgro Form 42 is similar to Form 44 in that it records the same information but is specifically used for recording metal parts that feed the fabrication of span bolsters used in the fabrication of the Atlas railcar. The form includes each part number, drawing number the part is required for, the heat number reflecting the raw metal plate the individual part is cut from, the quantity per car, the material the part is made from and any special testing required. The form also has a place for signature by Kasgro quality control personnel indicating acceptance. Non-conforming parts are not included as they are not accepted into an in-process railcar fabrication. FS approved forms are enclosed in Appendix B.1.4.

4.2.3.1.5 New Car Inspection Form, Form 5-12-B

This form is driven by AAR's *Manual of Standards and Recommended Practices, Section C, Part II, Design, Fabrication and Construction of Freight Cars* [3]. The form is completed by qualified Kasgro personnel for each fabricated railcar and is the final Kasgro inspection prior to issuance of a railcar's Certificate of Conformance to the customer. Part numbers are listed and checked to traceable documents for major components. Air brake settings and bearing clearances are measured and recorded for tracking future wear. Overall railcar dimensions are verified and recorded. Results of various functional tests are reviewed and recorded for reference, and final acceptance tests are completed including:

- Single Car Air Brake Test: review and verification of the railcar's single car air brake test as described in Section 4.2.3.5;
- Brake Pipe Restriction Test: a Brake Pipe Restriction Test is performed on the railcar as required in AAR's *Manual of Standards and Recommended Practices, Section E, Standard S-471* [20];



- Slack Adjuster Test: specific review and verification of the railcar's slack adjustment test results performed during the single car air brake test;
- Golden Shoe Test: using a calibrated force measuring brake shoe (Golden Shoe), the railcar's applied brake shoe force is measured to ensure compliance to AAR's *Manual of Standards and Recommended Practices, Section E, Standard S-401* [21];
- Truck Curve Test: per the AAR's *Manual of Standards and Recommended Practices*, a clearance test is performed on the first article railcar only [22]. For every railcar which has a New Car Inspection form completed, verification is made, and results are reviewed that the first article railcar traveled a curved section of railroad track having a radius of approximately 150 feet while observers verified there was no interference between the railcar's body, trucks and suspension components, and brake components;
- Load Test: verification and review that the railcar's weight distribution was measured and meets specification per Kasgro Procedure #13, Revision 4, titled *Car Weighting Procedure* as described in Section 4.2.3.2.3.

The new car inspection process also verifies that operational railcar settings for locknuts on brake slack adjuster triggers are properly set, cross key retainer bolts are properly torqued, safety tabs are bent over tri-span-to-center pin bolts, and center pin travel for trucks and car bodies are measured and recorded for proper range and future wear measurements. Railcar stenciling is checked along with the orientation and presence of truck cover plates and pigtail protective covers.

The FS approved New Car Inspection Form is enclosed in Appendix B.1.5.

4.2.3.1.6 Nonconformance Reports

Nonconformance issues for the Atlas railcar are:

1. Cradle attachment pin blocks and end stop pin blocks not fabricated with required stainless-steel cladding – Kasgro NC #2;
2. Fabrication of pin guide tray – Kasgro NC #3
3. End stop pin block hole tolerances – Kasgro NC #4
4. Cradle attachment pin block hole tolerances – Kasgro NC #5
5. Shear block dimensional tolerance – Kasgro NC #6
6. Amsted Rail Swing-Motion Truck Spring Retention Bosses – See Section 4.2.3.3.3 for additional details.

The above described NCRs #2, #4, #5 and #6 represent common fabrication occurrences when welding and boring thick metal plates to the small tolerances required for the cradle attachment assembly as reflected in drawing, DWG-3018956, *Atlas Railcar Cradle Attachment* (reference Section 4.2.2.1). As part of the evaluation of the NCRs, the fit of the conceptual cradle designs was checked against the as-built conditions represented in the NCRs. In all of the NCR evaluations, the form, fit and function of the cradle attachments and the conceptual cradle designs were not compromised; therefore, the NCRs were evaluated and dispositioned for a use-as-is condition. NCRs for the above items 1-5 are included in Appendix B.1.6 along with the FS SNR; item 6 is included in Appendix B.3.6.



4.2.3.1.7 Certificate of Conformance

A Certificate of Conformance (CoC) is provided for each railcar by Kasgro upon completion of the railcar's fabrication, all in-process inspections, and the completion of the New Car Inspection Form (see Section 4.2.3.1.5). The FS approved CoC for the Atlas railcar is enclosed in Appendix B.1.7.

4.2.3.2 Special Process Inspection Documentation

Described in the following subsections is inspection documentation supporting special processes due to S-2043, AAR requirements or critical fabrication and assembly requirements such as brake testing, testing jack and lug fixtures, balancing the weight of the railcar on each axle, or testing of spring tolerances.

4.2.3.2.1 Securing and Jack Lug Proof Test Certification Form, Form 45

The Atlas railcar is to be secured against movement during cask loading and unloading by four tie-down securement lugs and jacking plates (see Appendix K, General Loading Procedures. This test duplicates actual loading and unloading operations of the Atlas railcar and is performed to ensure future safe operations. Appendix B.2.1 is the completed form used to collect test data and provide for approval of the test.

4.2.3.2.2 Spring Test Requirements and Tolerance Procedure #12

The specifications of the springs used in the Atlas trucks are very important in meeting AAR S-2043 performance guidelines for the Atlas railcar. Spring tolerance for meeting AAR S-2043 performance requirements for spring load height is narrower than industry standards for non-S-2043 railcars. To ensure that S-2043 performance requirements are consistently met, Kasgro has developed a procedure to test 100% of truck springs utilized in the applicable Atlas trucks. Springs are tested by the supplier before shipment to the requirements of Kasgro Procedure 12. Appendix B.2.2 includes the Kasgro developed procedure used to determine acceptable truck springs and Form 69 reflecting acceptance by Kasgro of conforming springs from Wabtec Spring.

4.2.3.2.3 Brake Cylinder Piston Travel Adjustment Procedure #14

This procedure was developed by Kasgro specifically for 12-axle railcars. It provides guidance for adjusting brake cylinder travel while removing the impact from the elastomer adapter pads in the Amsted Swing-Motion truck frames. The procedure is enclosed in Appendix B.2.3 and provides the procedure in pages 1-5 and the Atlas railcar's recorded brake cylinder travel data on pages 6-9.

4.2.3.2.4 Railcar Weighting Form, Form 46-A

Weighting of the Atlas railcar and the railcar's weight distribution between its trucks is fundamental to ensuring that the Atlas railcar meets AAR S-2043 modeled and tested performance guidelines. The weighting of the railcar and its trucks provides data with respect to payload capacity, is necessary for properly marking the railcar's stenciled weight markings, and provides data allowing the proper shimming of the truck center pins before final assembly during the railcar's assembly process.

Included in Phase 2, Appendix G-2.4.1 is Kasgro Procedure #13, Revision 5, titled *Car Weighting Procedure* which is used to determine the weight distribution of a simulated payload on the S-2043



railcar. Enclosed in Appendix B.2.4 is the completed Form 46-A for recording of the individual truck weights for the Atlas railcar.

4.2.3.2.5 Static Force Brake Test Data, Form 36-A

Static air brake testing must follow the AAR's Manual of Standards and Recommended Practices, Section E, Standard S-486 [23] to demonstrate compliance to AAR S-2043 paragraph 5.3 [24]. The results of the required static brake force testing are enclosed as Appendix B.2.5.

4.2.3.2.6 Single Car Air Brake Test Report, Form 6-A

A railcar's pneumatic brake system must be functionally tested and include 100% of the braking system components. Functional system testing of the pneumatic braking system is to the specific equipment's specifications, in this case the New York Air Brake DB-60 system. Appendix B.2.6 records the results of the functional test of the brake system, records air brake piston travels, and also records any necessary repairs that may have been required as a result of the static air brake test; no repairs were required.

4.2.3.2.7 AAR Witness Letter for Single Car Brake Test Results

Brake tests are to be observed by an AAR field inspector and confirmation of successfully passing the functional single car brake tests must be received before the railcar can be released for commercial service. In addition to the AAR witnessing the single car brake tests as discussed above in Section 4.2.3.2.6, a representative from TTCI also witnessed the Atlas brake tests. A copy of the letters from the AAR and TTCI representative reflecting successful completion of the single car brake tests are included in Appendix B.2.7.

4.2.3.2.8 NDE & Weld Examination Results – Atlas Railcar Fabrication

Non-Destructive Examination (NDE) testing is based on industry standard testing protocols from American Welding Society (AWS) standard D15.1 for *Railroad Welding Specification for Cars and Locomotives* [25] and includes ultrasonic testing, visual inspection, liquid penetrant testing and magnetic particle testing. However, to meet AAR S-2043, Section 4.1.10, *Weld Analysis* [26], test sample size requirements are 100% for visual inspection identified as full-penetration butt welds or critical structural welds, and 10% random nondestructive inspection for all welds not identified as full-penetration butt welds or critical structural welds. Finally, all inspections, including visual, must be performed by an AWS-certified inspector. Due to this requirement, Kasgro Rail has contracted all NDE inspection to TUV Rheinland who maintains their own NDE inspection procedures and AWS-certified personnel. Appendix B.2.9 includes in chronological order the NDE results for ultrasonic testing, visual inspection, liquid penetrant testing and magnetic particle testing for the Atlas railcar.

4.2.3.3 Other Inspection Documentation

The following subsections contain descriptions of inspection documentation to ensure that the Atlas railcar meets contractual requirements such as AAR Plate E size envelope requirements, functional requirements such as pin block placement critical to cradle and end stop fitment, and FRA and supplier requirements. Also included are documents supporting the replacement of Amsted Rail Swing-Motion truck spring retention bosses.



4.2.3.3.1 Railcar Attachment Dimensional Inspection

Kasgro performed dimensional inspections with FS oversight of the Atlas railcar's cradle pin block attachments, end stop pin block attachments, and shear blocks. The following describes the results of the dimensional inspections.

CMS Laser Dimensions Report

Kasgro Rail utilized a laser Coordinate Measurement System (CMS) service during the placement of the railcar's deck and its cradle and end stop pin blocks to ensure precise location placement. Kasgro also utilized the CMS service after welding of the pin blocks and shear blocks had been completed to ensure that movement due to heat stress did not occur. Enclosed in Appendix B.3.1, *CMS Laser Dimensions Report*, documents the laser inspection performed following welding. Some features were not within drawing tolerance and these were documented on the CMS deviation report.

The center four pin blocks slots were found to be out of positional tolerance as documented on CMS report features 29-36 for DWG-3018956-000 items 7 and 8. Upon closer inspection it was determined that weld shrinkage of the Item 7 and 8 center pin blocks had reduced the height location between the slot center and the Datum A surface (top of cradle support pad, 3018956-000 Item 6). Rework was performed by Kasgro to reduce the thickness of the Item 6 pads, correcting the required 9.50-inch interface height. The final condition was inspected by Kasgro and found to be within tolerance. As this was rework, no nonconformance was generated.

The center four pin block slots were also found to be undersized during the laser inspection. This was documented on a Kasgro NC and evaluated by FS. See Section 4.2.3.1.6 for more information.

Federal Services Dimensional Inspection Worksheet

The Atlas railcar was inspected by Kasgro using several different methods and at several different times following rework or repair. FS created the As-Built Dimensional Inspection report spreadsheet, See Appendix B3.2 to list all DWG-3018956-000 dimensions, their required tolerance, the inspected dimension/reference and the associated Kasgro nonconformance (NC) number where appropriate. Specific nonconforming conditions are listed in Section 4.2.3.1.6.

4.2.3.3.2 Atlas Cask Car Loaded Deck Height Document

As the Atlas railcar must meet Plate E envelope size requirements [21, 26], the Atlas' deck height was measured under a minimum load – approximately 215,000 pounds – to ensure its suspension and deck camber would allow it to meet the 57.00 inches calculated target load deck height above track rails. Appendix B.3.3 provides evidence of successfully having a maximum deck height of 56.875 inches when loaded with 215,000 pounds, which is below the calculated maximum deck height required to meet Plate E requirements for the most limiting payload.

4.2.3.3.3 Weld Inspection for Replacement of Spring Retention Bosses

The replacement of the Amsted Rail Swing-Motion truck bolster's spring retention boss is substantiated by the below weld inspection documents by Amsted Rail and Kasgro Rail. Although fundamental to the acceptance of the Atlas railcar by the DOE, the replacement of the truck bolster and its spring retention bosses legally occurred between Kasgro and Amsted Rail. As a result, FS does not provide a formal review of the below documents and provides them for information only. However, FS did have an observer present during the replacement of the truck bolsters, the Atlas reassembly, and the brake test



to ensure that acceptable spring retention bosses were utilized in the reassembly of the Atlas railcar. Also, per standard industry practices, rework and replacement activities do not have a nonconformance generated; therefore, FS did not perform a formal review of a Kasgro NCR by DTF and SDSR. However, FS had an engineer present to observe the replacement and inspection activities and includes the below documents in the Phase 3 report to provide verification by FS that acceptable spring retention bosses were placed on the Atlas railcar suitable for final acceptance by the DOE.

Amsted Weld Inspection Report

An enclosed copy of the Amsted Rail Corrective Action Report identifies the root cause and long-term corrective action for the improperly welded spring retention bosses on the Atlas railcar's Swing-Motion trucks. Also enclosed are photos of each replacement spring retention boss by bolster showing a proper weld and the acceptance of the welds by Amsted's CWI by use of his AWS stamp and signature. These documents are enclosed in Appendix B.3.4.

Kasgro Weld Inspection Report

Kasgro performed a visual inspection of the replacement spring retention blocks to the replacement truck bolsters to ensure the bosses were welded to the Amsted drawing requirements of ¼" full seam weld. All replacement spring bosses met this requirement. A copy of the TUV Rheinland's (Kasgro's NDE/CWI subcontractor) visual weld inspection report is included in Appendix B.3.5 to verify the mitigation of this issue.

AAR Nonconformance Report

Kasgro submitted the following AAR non-conformance documents to the AAR quality control organization regrading Amsted Rail's weld quality issues with the Atlas Swing-Motion truck bolster's spring retention bosses:

- QA-7.1, Association of American Railroads Quality Assurance Nonconformance Report Form to report Amsted's manufacturing defect in not meeting proper weld requirements;
- QA-7.2, Association of American Railroads Quality Assurance Nonconformance Response Form to report actions Amsted took to disposition the non-conformance;
- QA-7.3, Association of American Railroads Quality Assurance Nonconformance Response Evaluation Form to report that Kasgro has evaluated Amsted's disposition response in form QA-7.2 and found it acceptable.

The above documents are enclosed in Appendix B.3.6.

4.2.3.3.4 FRA Safety Appliance Compliance Letter

Kasgro submitted the following Atlas drawings to the FRA for review:

- 1155-1, *General Arrangement*
- 1155-3, *Stencil Arrangement*
- 1155-4, *Platform Arrangement*
- 1155-40, *Handbrake Arrangement*

These drawings were compared to requirements of:

- AAR Standard 2044, Appendix D1, *Safety Appliances for Flatcars with Full Decks* [27];
- 49 CFR Part 224, *Reflectorization of Rail Freight Rolling Stock* [28];



- 49 CFR Part 231.18, *Cars of Special Construction* [29].

Based on a review of the referenced Atlas drawings to the above listed requirements, the FRA found that the safety appliance arrangement, the handbrake arrangement and reflectorization application for the Atlas railcar was acceptable. On February 12, 2019, an FRA Region 2 inspector made a sample car inspection (a process similar to a first article inspection) of the Atlas railcar (railcar ID number IDOX 010001) and found the railcar compliant with applicable regulations. The FS reviewed FRA acceptance letter as enclosed in Appendix B.3.7.

4.2.3.3.5 Amsted / TTCI Supplier Certification Letters

A normal railroad industry occurrence is the performance of a Sample Car Inspection. This is performed by suppliers of a railcar's major components to ensure that the components are properly utilized and installed on a subject sample railcar. Once completed, the supplier provides a supplier certification letter attesting to the proper usage and installation of their major components on the sample railcar.

Amsted Rail performed a supplier inspection of the Atlas railcar for proper installation and testing of the railcar's DB60 braking system (Amsted Rail is the current owner of New York Brake). Also, as part of the Phase 4 Single Car testing, TTCI also was present to observe braking tests and provided a certification letter stating that the Atlas met AAR S-401 [21] and S-486 [23] requirements. These letters are enclosed in Appendix B.3.8.

4.2.3.4 Common Inspection Documentation

The following documents related to the as-built data package of the Atlas and buffer railcars are common to the fabrication of both prototype railcars. The common documentation has been included in Appendix B, *Atlas Fabrication Inspection Documentation* and Appendix F, *Buffer Railcar Fabrication Inspection Documentation* so that each appendix can stand alone during review of the Phase 3 report and as-built data package. References are included to both appendices.

4.2.3.4.1 Weld Procedure Qualification Records (PQR)

A weld Procedure Qualification Record (PQR) serves as a qualification record regarding Kasgro's compliance in meeting American Welding Society Standard D15.1 for *Railroad Welding Specification for Cars and Locomotives* [25]. The PQR covers the welding parameters used in the Welding Procedure Specification (WPS) document. In addition, it also includes relevant information, such as the welder's name and the name of the person who did the inspection, and the dates that the weld qualification was performed. The PQR is performed by a qualified individual welder and retained as a record of endorsement of the company and its product to industry standards.

FS approved PQRs for the Atlas railcar fabrication are enclosed in Appendix B.4.1 / Appendix F.4.1.

4.2.3.4.2 Weld Procedure Specifications (WPS) Records

A WPS is a set of welding instructions that aids in planning and ensuring quality control of product welds to its PQR, as well as future reproductions of the weld and its resulting product. In a WPS, required welding parameters referenced in applicable drawings are explained in the context of instructions. The purpose is to allow the welder to reproduce the product and its welds to a particular industry standard and quality.



FS approved PQRs for the Atlas railcar fabrication are enclosed in Appendix B.4.2 / Appendix F.4.2.

4.2.3.4.3 Kasgro Welder Qualifications Records

Per AWS Standard 15.1 [25], only welders who have qualified to weld a specific Welding PQR can perform the actual fabrication welding. Enclosed in Appendix B.4.3 / Appendix F.4.3 are the Kasgro welding qualifications for the prototype railcars.

4.2.3.4.4 Kasgro Personnel AAR S-486 Brake Test Certification

Personnel performing static air brake tests must be certified to AAR Standard S-486 [23]. A copy of the testing certificate, the written test and the supervised practical exam for the Kasgro operator performing the S-486 brake tests are included in Appendix B.4.4 / Appendix F.4.4.

4.2.3.4.5 AWS Weld Examination Inspector Certification

Kasgro utilizes TUV Rheinland as its NDE subcontractor and its AWS Standard 15.1 required AWS Certified Weld Inspector (CWI). Enclosed in Appendix B.4.5 / Appendix F.4.5 are copies of the certifications for the TUV Rheinland CWI utilized by Kasgro during the fabrication of the prototype railcars.

Also included in Appendix B.4.5 / Appendix F.4.5 is the certification for the Amsted Rail CWI that inspected the welds of the Atlas railcar's spring retention bosses on the replacement bolsters.

4.2.3.4.6 Measuring and Test Equipment Calibration Record, Kasgro Form 14 for Track Scale

The Atlas railcar was weighted to establish its operational light weight load limit (LL WT), and for use in the railcar weighting form (see Section 4.2.3.2.4). Since the track scale utilized by Kasgro is considered a piece of measurement equipment, it must be annually calibrated. A measuring and test equipment calibration record, Kasgro's Form 14, for its most recent track scale calibration performed on May 16, 2018 is enclosed as Appendix B.4.6 / Appendix F.4.6.

4.2.3.4.7 Safety Monitoring System Installation and Testing Results

The safety monitoring system utilized on the prototype railcars is manufactured by Lat-Lon, LLC of Denver, CO [30]. Lat-Lon installed and tested the basic operational status of the Atlas and buffer railcars at the Kasgro facility before the railcars were released for shipping. A letter from Lat-Lon confirming installation and a system health report indicating basic operation functions is included in Appendix B.4.7 / Appendix F.4.7. Full system testing will have to occur during single and multi-car testing during Phase 4 and Phase 5 of the project during operations of the prototype railcars with a suitable REV and locomotive.

4.2.3.4.8 Fabrication Specifications

A listing of fabrication-related specifications is included in Appendix B.4.8 / Appendix F.4.8. See Section 3.2 for additional detailed information regarding the specifications used during fabrication.



4.2.4 Bill of Materials and Vendors

The BOM for the Atlas cask railcar is included in Appendix C, *Atlas Railcar Bill of Materials and Vendors*. The BOM of material contains all materials and parts used in the fabrication of the Atlas railcar. Purchased materials and parts are listed by the specific material number or part number listed on Atlas railcar drawings. A description of each part number is provided, and the quantity purchased and utilized in the railcar's fabrication, not including any scrap allowances. AAR approved vendors qualified by specific material or part number and utilized by Kasgro are listed by specific material or part number with the approved vendor listed in the far-right column. Items that list as the vendor "AAR Vendor List" are generic items where the supplier is AAR approved, but specific materials or part numbers are not under an approval program; these items are typically common commodities such as nuts, bolts, washers, etc. and available from multiple suppliers. AAR approved suppliers are controlled under the AAR's M-1003 quality assurance program [19]. Additionally, as a result of another S-2043 cask railcar program, Kasgro has specifically qualified multiple vendors to supply common 12-axle railcar materials and parts under the control of the Kasgro Quality Assurance Manual approved under the AAR's M-1003 quality assurance program [19]. Fabrication consumables such as weld wire are not listed on the BOM as Kasgro maintains a usable inventory of these items at all times and they are specific to the equipment or fabrication process used by Kasgro Rail; however, these items are still specific to drawing requirements. Finally, as the safety monitoring system is a sole-sourced item, it has no item number and is shown on the BOM listing its specific vendor, Lat-Lon LLC.

4.2.5 Special Processes

Special process specifications for the Atlas railcar represent fabrication requirements for railcar acceptance industry standards, AAR standards and in-house processes developed for repeatability of railcar fabrication and specific material procurement specifications. Industry designated processes such as welding and NDE processes are utilized to set quality control acceptance requirements while meeting AAR standards. Special air brake tests ensure performance and functionality of the brake system to AAR requirements. Special process specifications also include fabrication and/or testing processes necessary to ensure AAR S-2043 performance guidelines are met such as spring testing and truck weight distribution weighting and shimming. Finally, additional special fabrication processes have been implemented based on experience by the railcar designer and fabricator, Kasgro Rail, with the other S-2043 cask railcar production to ensure repeatability and acceptance of the Atlas railcar. These processes include laser dimension measurements of the railcar deck and tie-down and jacking lug tests, both which should be continued in the fabrication of the Atlas cask railcar. Special processes are to be considered mandatory with no exceptions made in their application to the fabrication, inspection and testing of the Atlas railcar. The inspection documentation of these special processes is described in Section 4.2.3.2.

4.2.6 Atlas Railcar Operations and Maintenance Information

Basic railcar maintenance intervals and requirements are included in the AAR's *Field Manual of the AAR Interchange Rules* [31]. These maintenance activities are completed annually, periodically based on the mileage the railcar has travelled, or before the next routine operation of the railcar during routine service. In addition to these basic maintenance intervals and requirements, the Atlas railcar's specific periodic inspections, maintenance intervals, requirements and procedures are included in the *Atlas Railcar Supplemental Maintenance Manual, Revision 2*, enclosed as Appendix D.



For the Atlas railcar, specific areas of differences from basic AAR operational and maintenance requirements covered by the supplemental maintenance manual include:

- Pre-use inspections and annual inspections which are supported by detailed checklists included in this manual;
- Brake shoe replacement requirement also detailed by specific instructions in the manual;
- Atlas railcar long-term storage to prevent axle roller bearing seizure;
- Ellcon National truck mounted brake installation and field maintenance instruction;
- New York Air Brake DB-60 Brake System operations, maintenance and repair instruction manuals, and;
- Maintenance requirements, assembly procedures and instructional documents for Amsted Rail ASF-Keystone 100 Ton Swing Motion™ Truck with 12A Adapter Plus wedge pads.

Specific operational requirements are included in the general loading procedures enclosed as Appendix K, *General Loading Procedures, Revision 2*.

4.2.6.1 Updates to Phase 2 Appendix G-6, Atlas Railcar Operation and Maintenance Information Manual, Revision 1

Updates to the previous editions of the subject manual are:

- Correction of an incorrect brake model listed Item 6 of the document's Appendix A.1;
- The addition of Item 7 of the document's Appendix A.1 providing maintenance and contact information for Lat-Lon GPS Products' safety monitoring system.

4.3 Impacts to Atlas Railcar AAR EEC Notice to Proceed

No issues or conditions occurred during the fabrication of the Atlas railcar that would have any impact to the dynamic modeling results and the subsequent AAR EEC notification to proceed to the test phase for the Atlas railcar.



5.0 BUFFER PROTOTYPE RAILCAR

This section of the Phase 3 report and its accompanying Appendix E, F, G and H provide as-built fabrication information for the Atlas cask railcar.

5.1 Buffer Railcar Overview

A buffer railcar is designed for use in conjunction with Atlas cask railcars utilized in the shipments of HLRM. The buffer railcar structural design is symmetrical, end-to-end. The buffer railcar is designed to meet AAR Plate E requirements [21, 26] like the Atlas railcar. Furthermore, because it carries no cargo and has a very low height, it also easily meets AAR Plate C requirements [9]. The basic railcar design utilizes the same trucks as the escort railcar. These trucks will be fully tested in the single-car test phase. For the buffer railcar to meet AAR S-2043 performance guidelines, it must be heavy, so ballast weight was added to the railcar design. To minimize logistics and ensure consistent performance, the ballast weight was permanently built into the buffer railcar’s deck and framework.

Other specific design features of the buffer railcar are:

- Extreme Width..... 10’-8”
- Loading Deck Length..... 60’-0”
- Coupled Length 66’-4 5/8”
- Number of Axles 4
- Wheel Size 36”
- Minimum Turning Radius 150 feet
- Railcar design load limits:
 - Design total railcar truck capacity (based on 71,500 lbs/axle limit)..... 286,000 lbs
 - Design railcar empty weight (estimate based on total weight of empty railcar and permanent attachments)..... 263,000 lbs
 - Design railcar interchange load limit (based on conservative 65,750 lbs/axle operational constraints)..... 263,000 lbs
- Railcar operational load limits (as stenciled on side of railcar):
 - Gross Rail Load (GRL; actual weight; AAR definition as load limit + light weight)..... 263,000 lbs
 - Light Weight Load (LT LD; actual total weight of empty railcar and permanent attachments)..... 263,000 lbs
 - Load Limit (LD LMT; actual weight based on railcar operational payload capacity which is also the highest dynamic modeled weight)..... *0 lbs
 - Note: Per the Field Manual of the AAR Interchange Rules, Rule 88, B.1.d.(h) [8], when structural limitation of a car is less than truck capacity, a star symbol (*) must be applied to the left of the “LD LMT” stencil. Here, the “LD LMT *0 lbs” is used to denote a structural and operational payload limit of the greatest dynamic modeled weight

required to meet AAR S-2043 guidelines, and which is also the empty weight of the railcar with its built-in ballast weight and without any additional payload capacity. The railcar will be weighed during fabrication and the actual weight used in railcar markings.

FIGURE 5.1 – BUFFER RAILCAR

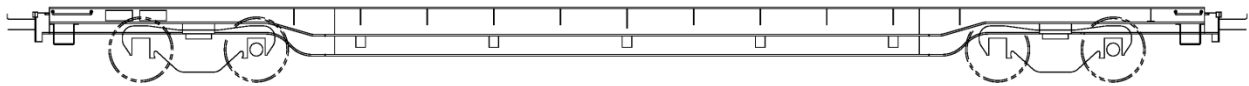

5.2 Buffer Railcar Deliverables

This section provides information regarding Phase 3 project deliverables for the buffer railcar. These deliverables include as-built fabrication drawings, fabrication inspection reports, material and vendor information, special processes, operations and maintenance information and a description of any impacts to the AAR notice to proceed due to fabrication of the buffer railcar.

5.2.1 Buffer Railcar As-Built Design Changes

As-built design changes for the buffer railcar are centered on the placement of safety appliances and an adjustment to the truck-mounted brake positions to ensure brake pad reach and pressure. These changes are reflected in the descriptions of the as-built drawing revisions in the following section

5.2.2 Buffer Railcar As-Built Fabrication Drawings

As-built fabrication drawings for the buffer railcar reflect its completed fabrication state including the cradle-to-railcar attachment interface system. The included drawings are listed in Table 5-1 and are enclosed in Appendix E, Buffer Railcar As-Built fabrication Drawings.

TABLE 5-1: KASGRO BUFFER RAILCAR AS-BUILT DRAWINGS

Drawing Number	Description	Revision ¹	Summary Description of Revision Change	Reference Appendix Item
1160-1	General Arrangement 110 Ton Straight Deck Flat	D	Revise safety appliances, revise bevel and add safety ladder to A-end of railcar	Appendix E-1
1160-2	Air Brake Arrangement 110 Ton Flat Car	E	Removal of electro-pneumatic braking system and associated revisions	Appendix E-2
1160-3	Stencil Arrangement	D	Addition of reflectors, emergency placard and general revision to stenciling arrangement	Appendix E-3
1160-4	Hand Brake Arrangement	C	Revision to add safety appliances and change in hand brake group designation	Appendix E-4
1160-5	Draft Sill Details	B	Revision to striker, auxiliary plate and plate Part 3-66	Appendix E-5



Title: Design and Prototype Fabrication of Railcars for Transport of High-Level Radioactive Material; Phase 3 – Prototype Fabrication and Delivery

Doc./Rev.: EIR-3021970-000

Project: 00225.03.0050 - DOE Atlas Project

1160-6	Bolster Assembly and Details	B	Changed from A-572 Grade 50 to Grade 60 and added cutout A	Appendix E-6
1160-7	Steel Details			Appendix E-7
1160-8	Steel Details			Appendix E-8
1160-9	Steel Details	B	Changed geometry and deleted bevel revised holes	Appendix E-9
1160-10	Steel Details			Appendix E-10
1160-11	Steel Details	A	Revised bevel	Appendix E-11
1160-12	Steel Details	B	Revised striker size and material	Appendix E-12
1160-13	Steel Details	A	Added holes 3-25	Appendix E-13
1160-14	Steel Details	B	Added Charpy test note, changed material to Grade 60, and added bevel	Appendix E-14
1160-15	Steel Details			Appendix E-15
1160-16	Deck Plate	B	Revised deck plate geometry/size	Appendix E-16
1160-17	Steel Details	A	Added Sill Step (Safety Appliance)	Appendix E-17
1160-18	Steel Details	A	Revised plate 3-39 size	Appendix E-18
1160-19	Hand Brake Details	B	Shortened part 3045 and updated as a general revision with safety appliance hand brake group U change	Appendix E-19
1160-20	Brake Badge Plate	B	Revised hand brake level dimensions and updated as a general revision with safety appliance hand brake group U change	Appendix E-20
1160-21	Hand Brake Steel Details			Appendix E-21
1160-22	Hand Brake Details			Appendix E-22
1160-23	Air Brake Steel Details	A	Added item 3-76	Appendix E-23
1160-24	Air Brake Steel Details			Appendix E-24
1160-25	Pipe Details			Appendix E-25
1160-26	Pipe Details			Appendix E-26
1160-27	Pipe Details	A	Revised dimension on item 4-B	Appendix E-27
1160-28	Brake Pipe Details			Appendix E-28
1160-29	Air Brake Details	A	Adjusted TMB (truck mounted brake) location	Appendix E-29
1160-30	Air Brake Details	A	Revised pipe item 4-11	Appendix E-30
1160-31	Air Brake Details			Appendix E-31



1160-32	Air Brake Steel Details			Appendix E-32
1160-33	Air Brake Steel Details			Appendix E-33
1160-34	Pipe Details			Appendix E-34
1160-35	Camber Diagram			Appendix E-35
1160-37	Pipe Details	A	Revised length	Appendix E-36
1160-40	Ballast Wt (Weight) Arrangement	C	Ballast revised per dynamic modeling, numbering and weights of deck ballast plates revised	Appendix E-37
1160-41	Dummy Wt (Weight)	A	Dummy weight dimensions revised per dynamic modeling	Appendix E-38
1160-42	Dummy Wt (Weight)	A	Dummy weight dimensions revised per dynamic modeling	Appendix E-39
1160-44	Locking Center Pins			Appendix E-40
1160-45	Steel Details	B	Miscellaneous drawing cleanup revisions, deleted items 92 and 93, added items 94 and 95	Appendix E-41
1160-46	Steel Details	A	Added in Phase 3; revision added item 3-100	Appendix E-42

Note: 1) The original issue of an approved drawing shows no revision level; first revision is listed as revision "A".

5.2.3 Buffer Railcar Inspection Documentation

The following subsections provide information and reference evidence of the buffer railcars’ fabrication to contract requirements, specifications, standards, Kasgro procedures and drawing requirements. Fabrication and inspection documentation to support the acceptance of the buffer railcars are presented as:

- a) Buffer Railcar Fabrication Inspection Documentation – those documents supporting Kasgro fabrication processes;
- b) Special Process Inspection Documentation – documents supporting special processes due to S-2043 or AAR requirements;
- c) Other Inspection Documentation – other documentation to support contractual and other non-routine requirements, and;
- d) Common Inspection Documentation – common documents supporting both the acceptance of the Atlas and buffer railcars.

In addition to the Kasgro produced inspection documentation provided in Appendix F accompanying each subsection topic, a FS DTF and SDSR form are included reflecting a formal FS review, revision/correction if necessary by Kasgro, and approval of all Kasgro provided inspection documentation.



5.2.3.1 Buffer Railcar Fabrication Inspection Documentation

The following subsections describe Kasgro fabrication and related inspection processes and the forms used to record the results of those inspections.

5.2.3.1.1 Buffer Railcar Travelers

Kasgro utilizes detailed drawings with specification and fabrication instruction callouts by major railcar assembly operation and/or component track and monitor fabrication. Fabrication travelers typically reflect a collection of the applicable drawing(s), part number and material control number lists, and inspection and heat lot records for utilized parts and subassemblies. Therefore, the traveler also serves as a quality control record and quality assurance summary document. The traveler includes a listing of the assembly operators performing the fabrication operations, the operators' supervisor(s) and the applicable inspector(s). The Kasgro inspector's signature confirms that the fabricated assembly is acceptable to applicable drawing and specification requirements before it is released to the next stage of railcar assembly. Travelers are enclosed in Appendix F.1.1 that prove the occurrence of this process for the buffer railcars. This traveler process was also observed, reviewed and approved by signature by FS QA personnel during the buffer railcars' fabrication as shown on the enclosed travelers.

5.2.3.1.2 Burning Table Inspection Report, Form 9Z and 9Z-A

The Kasgro *Burning Table Inspection Report* is a form used to record acceptable large-scale steel materials parts cut by an outside contractor (Form 9Z) or as cut on the Kasgro plasma cutting (burn) table (Form 9Z-A). These forms are used to record that cut materials meet drawing requirements. Non-conforming materials are never accepted and therefore, never recorded on these inspection reports. The burning table inspection reports also have a table of sampling size listed for reference and a location for an inspector approved to the Kasgro QA requirements under AAR M-1003 to sign for acceptance of the listed plasma-cut items. FSF approved Forms 9Z and 9Z-A for the buffer railcars are enclosed in Appendix F.1.2.

5.2.3.1.3 Car Body – Heat Identification Form, Form 44B

Kasgro Form 44B is used to record individual metal parts utilized in the fabrication of each individual railcar structure and deck. The form includes each part number, drawing number the part is required for, the heat number reflecting the raw metal plate the individual part is cut from, the quantity per car, the material the part is made from and any special testing required. The form also has a place for signature by Kasgro quality control personnel indicating acceptance. Non-conforming parts are not included as they are not accepted into an in-process railcar fabrication. FS approved forms are enclosed in Appendix F.1.3.

5.2.3.1.4 New Car Inspection Form, Form 5-12-B

This form is driven by AAR's *Manual of Standards and Recommended Practices*, Section C, Part II, *Design, Fabrication and Construction of Freight Cars* [3]. The form is completed by qualified Kasgro personnel for each fabricated railcar and is the final Kasgro inspection prior to issuance of a railcar's Certificate of Conformance to the customer. Part numbers are listed and checked to traceable documents for major components. Air brake settings and bearing clearances are measured and recorded for tracking future wear. Overall railcar dimensions are verified and recorded. Results of



various functional tests are reviewed and recorded for reference, and final acceptance tests are completed including:

- **Single Car Air Brake Test:** review and verification of the railcar's single car air brake test as described in Section 5.2.3.2.2;
- **Brake Pipe Restriction Test:** a Brake Pipe Restriction Test is performed on the railcar as required in AAR's Manual of Standards and Recommended Practices, Section E, Standard S-471 [20];
- **Slack Adjuster Test:** specific review and verification of the railcar's slack adjustment test results performed during the single car air brake test;
- **Golden Shoe Test:** using a calibrated force measuring brake shoe (Golden Shoe), the railcar's applied brake shoe force is measured to ensure compliance to AAR's Manual of Standards and Recommended Practices, Section E, Standard S-401 [21];
- **Truck Curve Test:** per the AAR's Manual of Standards and Recommended Practices, a clearance test is performed on the first article railcar only [22]. For every railcar which has a New Car Inspection form completed, verification is made, and results are reviewed that the first article railcar traveled a curved section of railroad track having a radius of approximately 150 feet while observers verified there was no interference between the railcar's body, trucks and suspension components, and brake components;

The new car inspection process also verifies that operational railcar settings for locknuts on brake slack adjuster triggers are properly set, cross key retainer bolts are properly torqued, safety tabs are bent over tri-span-to-center pin bolts, and center pin travel for trucks and car bodies are measured and recorded for proper range and future wear measurements. Railcar stenciling is checked along with the orientation and presence of truck cover plates and pigtail protective covers.

The FS approved New Car Inspection Form for the buffer railcars are enclosed in Appendix F.1.4.

5.2.3.1.5 Nonconformance Reports

There were no nonconformance reports generated during the fabrication of the buffer railcars.

5.2.3.1.6 Certificate of Conformance

A Certificate of Conformance (CoC) is provided for each railcar by Kasgro upon completion of the railcar's fabrication, all in-process inspections, and the completion of the New Car Inspection Form (see Section 5.2.3.1.4). The FS approved CoCs for the buffer railcars are enclosed in Appendix F.1.5.

5.2.3.2 Special Process Inspection Documentation

Described in the following subsections is inspection documentation supporting special processes due to S-2043, AAR requirements or critical fabrication and assembly requirements such as brake system testing and NDE testing.



5.2.3.2.1 Static Force Brake Test Data, Form 36-A

Static air brake testing must follow the AAR's Manual of Standards and Recommended Practices, Section E, Standard S-486 [23] to demonstrate compliance to AAR S-2043 paragraph 5.3 [24]. The results of the required static brake force testing are enclosed as Appendix F.2.1.

5.2.3.2.2 Single Car Air Brake Test Report, Form 6-A

A railcar's pneumatic brake system must be functionally tested and include 100% of the braking system components. Functional system testing of the pneumatic braking system is to the specific equipment's specifications, in this case the New York Air Brake DB-60 system. Appendix F.2.2 records the results of the functional test of the buffer railcars' brake system, records air brake piston travels, and also records any necessary repairs that may be required as a result of the static air brake test; no repairs were required.

5.2.3.2.3 AAR Witness Letter for Single Car Brake Test Results

Brake tests are to be observed by an AAR field inspector and confirmation of successfully passing the functional single car brake tests must be received before the railcar can be released commercial operations. In addition to the AAR witnessing the single car brake tests as discussed above in Section 5.2.3.2.2, a representative from TTCI also witnessed the buffer railcar brake tests. A copy of the letters from the AAR and TTCI representative reflecting successful completion of the single car brake tests are included in Appendix F.2.3.

5.2.3.2.4 NDE & Weld Examination Results – Buffer Railcar Fabrication

NDE testing is based on industry standard testing protocols from American Welding Society (AWS) standard D15.1 for *Railroad Welding Specification for Cars and Locomotives* [25] and includes ultrasonic testing, visual inspection, liquid penetrant testing and magnetic particle testing. However, to meet AAR S-2043, Section 4.1.10, Weld Analysis [26], test sample size requirements are 100% for visual inspection identified as full-penetration butt welds or critical structural welds, and 10% random nondestructive inspection for all welds not identified as full-penetration butt welds or critical structural welds. Finally, all inspections, including visual, must be performed by an AWS-certified inspector. Due to this requirement, Kasgro Rail has contracted all NDE inspection to TUV Rheinland who maintains their own NDE inspection procedures and AWS-certified personnel. Appendix B.2.9 includes the NDE results for ultrasonic testing, visual inspection, liquid penetrant testing and magnetic particle testing for the buffer railcar.

5.2.3.3 Other Inspection Documentation

The following subsections contain descriptions of inspection documentation to ensure that the buffer railcars meet FRA and supplier requirements.

5.2.3.3.1 FRA Safety Appliance Compliance Letter

Kasgro submitted the following buffer railcar drawings to the FRA for review:

- 1160-1, *General Arrangement*
- 1160-3, *Stencil Arrangement*
- 1160-4, *Platform Arrangement*



These drawings were compared to requirements of:

- AAR Standard 2044, Appendix D1, *Safety Appliances for Flatcars with Full Decks* [27];
- 49 CFR Part 224, *Reflectorization of Rail Freight Rolling Stock* [28];
- 49 CFR Part 231.18, *Cars of Special Construction* [29].

Based on a review of the referenced buffer railcar drawings to the above listed requirements, the FRA found that the safety appliance arrangement, the handbrake arrangement and reflectorization application for the buffer railcars was acceptable. On October 30, 2018, an FRA Region 2 inspector made a sample car inspection (a process similar to a first article inspection) of the buffer railcar ID number IDOX 020002 and found the railcar compliant with applicable regulations. The FS reviewed FRA acceptance letter as enclosed in Appendix F.3.1

5.2.3.3.2 Amsted / TTCI Supplier Certification Letters

A normal railroad industry occurrence is the performance of a Sample Car Inspection. This is performed by suppliers of a railcar's major components to ensure that the components are properly utilized and installed on a subject sample railcar. Once completed, the supplier provides a supplier certification letter attesting to the proper usage and installation of their major components on the sample railcar.

Amsted Rail performed a supplier inspection of the buffer railcars for proper installation and testing of the railcar's DB60 braking system (Amsted Rail is the current owner of New York Air Brake) and the buffer railcar trucks including the damper. Also, as part of the Phase 4 Single Car testing, TTCI also was present to observe braking tests and provided a certification letter stating that the buffer railcar met AAR S-401 [21] and S-486 [23] requirements. These letters are enclosed in Appendix F.3.2.

5.2.3.4 Common Inspection Documentation

The following documents related to the as-built data package of the Atlas and buffer railcars are common to the fabrication of both prototype railcars. The common documentation has been included in Appendix B, *Atlas Fabrication Inspection Documentation* and Appendix F, *Buffer Railcar Fabrication Inspection Documentation* so that each appendix can stand alone during review of the Phase 3 report and as-built data package. References are included to both appendices.

5.2.3.4.1 Weld Procedure Qualification Records (PQR)

A weld Procedure Qualification Record (PQR) serves as a qualification record regarding Kasgro's compliance in meeting American Welding Society Standard D15.1 for *Railroad Welding Specification for Cars and Locomotives* [25]. The PQR covers the welding parameters used in the Welding Procedure Specification (WPS) document. In addition, it also includes relevant information, such as the welder's name and the name of the person who did the inspection, and the dates that the weld qualification was performed. The PQR is performed by a qualified individual welder and retained as a record of endorsement of the company and its product to industry standards.

FS approved PQRs for the Atlas railcar fabrication are enclosed in Appendix B.4.1 / Appendix F.4.1.

5.2.3.4.2 Weld Procedure Specifications (WPS) Records

A WPS is a set of welding instructions that aids in planning and ensuring quality control of product welds to its PQR, as well as future reproductions of the weld and its resulting product. In a WPS,



required welding parameters referenced in applicable drawings are explained in the context of instructions. The purpose is to allow the welder to reproduce the product and its welds to a particular industry standard and quality.

FS approved PQRs for the Atlas railcar fabrication are enclosed in Appendix B.4.2 / Appendix F.4.2

5.2.3.4.3 Kasgro Welder Qualifications Records

A WPS is a set of welding instructions that aids in planning and ensuring quality control of product welds to its PQR, as well as future reproductions of the weld and its resulting product. In a WPS, required welding parameters referenced in applicable drawings are explained in the context of instructions. The purpose is to allow the welder to reproduce the product and its welds to a particular industry standard and quality.

FS approved PQRs for the buffer railcar fabrication are enclosed in Appendix B.4.3 / Appendix F.4.3.

5.2.3.4.4 Kasgro Personnel AAR S-486 Brake Test Certification

Personnel performing static air brake tests must be certified to AAR Standard S-486 [23]. A copy of the testing certificate, the written test and the supervised practical exam for the Kasgro operator performing the S-486 brake tests are included in Appendix B.4.4 / Appendix F.4.4.

5.2.3.4.5 AWS Weld Examination Inspector Certification

Kasgro utilizes TUV Rheinland as its NDE subcontractor and its AWS Standard 15.1 required AWS Certified Weld Inspector (CWI). Enclosed in Appendix B.4.5 / Appendix F.4.5 are copies of the certifications for the TUV Rheinland CWI utilized by Kasgro during the fabrication of the prototype railcars.

5.2.3.4.6 Measuring and Test Equipment Calibration Record, Kasgro Form 14 for Track Scale

The prototype buffer railcars were weighted to establish their operational light weight load limit (LL WT), and gross rail load (GRL), which happen to be the same. Since the track scale utilized by Kasgro is considered a piece of measurement equipment, it must be annually calibrated. A measuring and test equipment calibration record, Kasgro's Form 14, for its most recent track scale calibration performed on May 16, 2018 is enclosed as Appendix B.4.6 / Appendix F.4.6.

5.2.3.4.7 Safety Monitoring System Installation and Testing Results

The safety monitoring system utilized on the prototype railcars is manufactured by Lat-Lon, LLC of Denver, CO [30]. Lat-Lon installed and tested the basic operational status of the Atlas and buffer railcars at the Kasgro facility before the railcars were released for shipping. A letter from Lat-Lon confirming installation and a system health report indicating basic operation functions is included in Appendix B.4.7 / Appendix F.4.7. Full system testing will have to occur during single and multi-car testing during Phase 4 and Phase 5 of the project during operations of the prototype railcars with a suitable escort railcar and locomotive.



5.2.3.4.8 Fabrication Specifications

A listing of fabrication-related specifications is included in Appendix B.4.8 / Appendix F.4.8. See Section 3.2 for additional detailed information regarding the specifications used during fabrication.

5.2.4 Bill of Materials and Vendors

The BOM for the buffer railcar is included in Appendix G, *Buffer Railcar Bill of Materials and Vendors*. The BOM contains all materials and parts used in the fabrication of the buffer railcar. Purchased materials and parts are listed by the specific material number or part number listed on the buffer railcar drawings. A description of each part number is provided and the quantity purchased and utilized in the railcar's fabrication, not including any scrap allowances. AAR approved vendors qualified by specific material or part number and utilized by Kasgro are listed by specific material or part number with the approved vendor listed in the far-right column. Items that list as the vendor "AAR Vendor List" are generic items where the supplier is AAR approved, but specific materials or part numbers are not under an approval program; these items are typically common commodities such as nuts, bolts, washers, etc. and available from multiple suppliers. AAR approved suppliers are controlled under the AAR's M-1003 quality assurance program [19]. Fabrication consumables such as weld wire are not listed on the BOM of materials as Kasgro maintains a usable inventory of these items at all times and they are specific to the equipment or fabrication process used by Kasgro Rail; however, these items are still specific to drawing requirements. Finally, as the safety monitoring system is a sole-sourced item, it has no item number and is shown as the last item on the BOM and listing its specific vendor, Lat-Lon LLC.

5.2.5 Special Processes

Special process specifications for the buffer railcar represent fabrication requirements for railcar acceptance industry standards, AAR standards and in-house processes developed for repeatability of railcar fabrication and specific material procurement specifications. Industry designated processes such as welding and NDE processes are utilized to set quality control acceptance requirements while meeting AAR standards. Special air brake tests ensure performance and functionality of the brake system to AAR requirements. Special processes are to be considered mandatory with no exceptions made in their application to the fabrication, inspection and testing of the buffer railcar. The inspection documentation of these special processes is described in Section 5.2.3.2

5.2.6 Buffer Railcar Operations and Maintenance Information

Basic railcar maintenance intervals and requirements are included in the AAR's *Field Manual of the AAR Interchange Rules* [31]. These maintenance activities are completed annually, periodically based on the mileage the railcar has travelled, or before the next routine operation of the railcar of during routine service. In addition to these basic maintenance intervals and requirements, the buffer railcar's specific periodic inspections, maintenance intervals, requirements and procedures are included in the *Buffer Railcar Supplemental Maintenance Manual, Revision 2*, enclosed as Appendix H.

For the buffer railcars, specific areas of differences from basic AAR operational and maintenance requirements covered by the supplemental maintenance manual include:

- Pre-use inspections and annual inspections which are supported by detailed checklists included in this manual;
- Brake shoe replacement requirement also detailed by specific instructions in the manual;



- Buffer railcar long-term storage to prevent axle roller bearing seizure;
- Ellcon National truck mounted brake installation and field maintenance instruction;
- New York Air Brake DB-60 Brake System operations, maintenance and repair instruction manuals, and;
- Maintenance requirements, assembly procedures and instructional documents for MeridianRail AMTRACK Swing Motion Trucks.

There are no specific operational requirements for the buffer railcar other than that it is not to carry a payload or other load due to its weight. A stencil stating “NO LOAD” is painted on top of it deck and should be repainted if missing or determined unreadable.

5.2.6.1 Updates to Phase 2 Appendix H-6, Buffer Railcar Operation and Maintenance Information Manual

A update to the previous editions of the subject manual is:

- The addition of Item 7 of the document’s Appendix A.1 providing maintenance and contact information for Lat-Lon GPS Products’ safety monitoring system.

5.3 Impacts to Buffer Railcar AAR EEC Notice to Proceed

No issues or conditions occurred during the fabrication of the buffer railcars that would have any impact to the dynamic modeling results and the subsequent AAR EEC notification to proceed to the test phase for the buffer railcars.

6.0 TEST LOAD DESIGNS

This section presents an overview of the minimum and maximum test loads, their related test cradles and the Atlas railcar ballast test load.

In Phase 2, initial dynamic modeling scoping was performed by TTCI to determine the requirements of the analysis necessary to meet the requirements of S-2043 for the 17 different cask/cradles payloads that can be transported by the Atlas Railcar. Physical single and multi-car testing requirements have not yet been defined. The test loads presented in Phase 2, *Test Load Conceptual Designs* [32], were based on three load conditions: empty condition, maximum load/highest cg condition and an additional empty cask condition as originally proposed in the dynamic modeling plan. Final test conditions will be specified by TTCI.

During the development of the test load conceptual designs it was identified that additional design details would be required to meet site specific lift requirements at TTCI. Based on crane limits a modular test load design was required and the simple conceptual designs were enhanced and further developed into design drawings which are currently being used for test load fabrication. This modular design allows for the TTC test facility to use its current cranes to lift and place the required test load on the Atlas railcar during Phase 4 and 5 testing (see Section 3.3.2 for additional information).

A description of each of the test loads is provided below. The calculation developed and used to generate the design drawings is included in Appendix I.1

6.1 Empty Railcar Ballast Load Description and Design

A ballast weight payload which is not representative of a cask design is used to weight the Atlas railcar in an empty condition so that it will meet AAR S-2043 guidelines; when placed on an Atlas railcar this is referred to as Minimum Condition 1. The design of the ballast weight payload has not changed between the Phase 2 conceptual design and the Phase 3 fabrication design. The fabrication design drawing – DWG-3020457-001 – is included in Appendix I.2.

FIGURE 6.1 – BALLAST LOAD

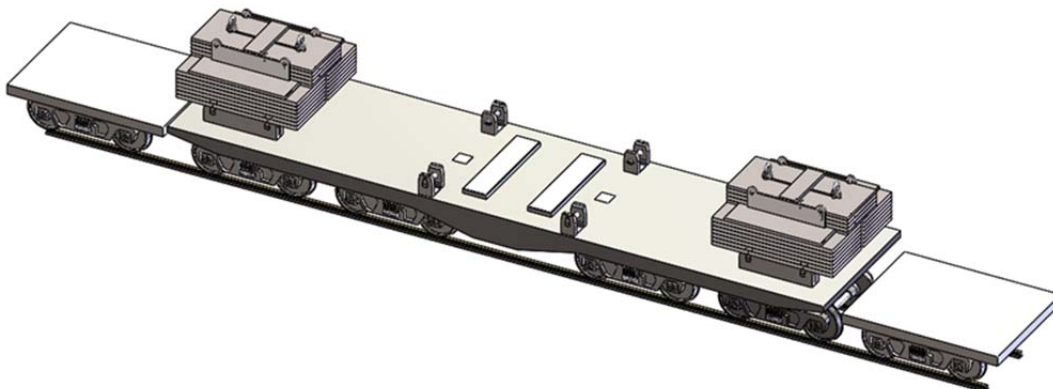

6.2 Minimum Test Load and Cradle Description and Design

The minimum test load weight and minimum test load cradle mimic an empty MP197 cask payload; when placed on an Atlas railcar this is referred to as Minimum Condition 2. The inertial properties (weight, CG and MMI) of the minimum condition test load and its accompanying minimum test load cradle are based on the Phase 2 conceptual design drawings for:

- Minimum Condition Test Load – Drawing 3020458-000;
- Minimum Condition Test Load Cradle – Drawing 3020459-000.

A calculation (see Appendix I.1) was performed and the resulting Phase 3 fabrication design drawings were generated:

- Central Assembly (aka: Strongback Main Beam), Atlas Railcar Test Load – Drawing 3020935-001;
- Minimum Condition Test Load – Drawing 3020458-001;
- Minimum Condition Test Load Cradle – Drawing 3020459-001.

The above fabrication design drawings are included in Appendix I.7, Appendix I.3 and Appendix I.4, respectively. The strongback main beam and its major components are depicted in Figure 6.2 and the minimum test load is depicted on an Atlas railcar in Figure 6.3.

FIGURE 6.2 – THE CENTRAL ASSEMBLY AND MINIMUM TEST LOADS

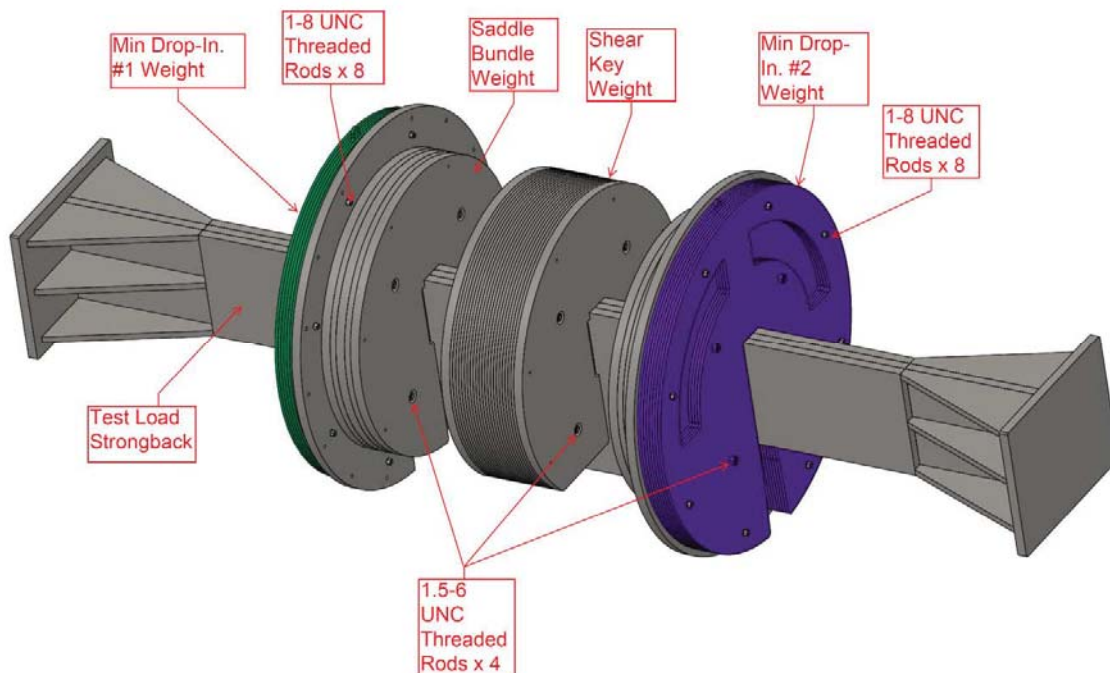

Note: Colors on test load are for illustration purposes only

FIGURE 6.3 – THE MINIMUM TEST LOAD AND MINIMUM TEST LOAD CRADLE

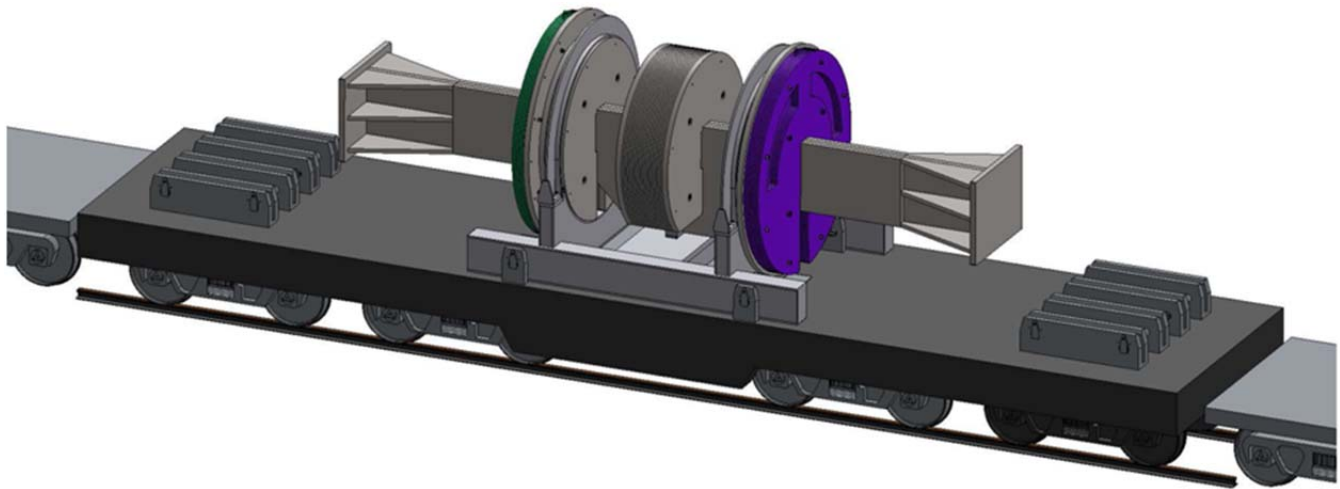

Note: Colors on test load are for illustration purposes only

6.3 Maximum Test Load and Cradle Description and Design

The maximum test load weight, maximum test load cradle and end stops mimic a loaded HI-STAR 190 XL cask payload; when placed on an Atlas railcar this is referred to as the Maximum Condition. The inertial properties (weight, CG and MMI) of the maximum condition test load and its accompanying maximum test load cradle are based on the Phase 2 conceptual design drawings for:

- Maximum Condition Test Load – Drawing 3020460-000;
- Maximum Condition Test Load Cradle (and End Stops) – Drawing 3020461-000.

A calculation (see Appendix I.1) was performed and the resulting Phase 3 fabrication design drawings were generated so when combined, they achieve the maximum payload mimicking the HI-STAR 190 XL payload:

- Central Assembly (aka: Strongback Main Beam), Atlas Railcar Test Load – Drawing 3020935-001;
- Minimum Condition Test Load – Drawing 3020458-001;
- Maximum Condition Test Load – Drawing 3020460-001;
- Maximum Condition Test Load Cradle (and End Stops) – Drawing 3020461-001.

The above fabrication design drawings are included in Appendix I.7, Appendix I.3, Appendix I.5 and Appendix I.6, respectively. The maximum test load is depicted on an Atlas railcar in Figure 6.4.

FIGURE 6.4 – THE MAXIMUM TEST LOAD, MAXIMUM TEST LOAD CRADLE AND END STOPS

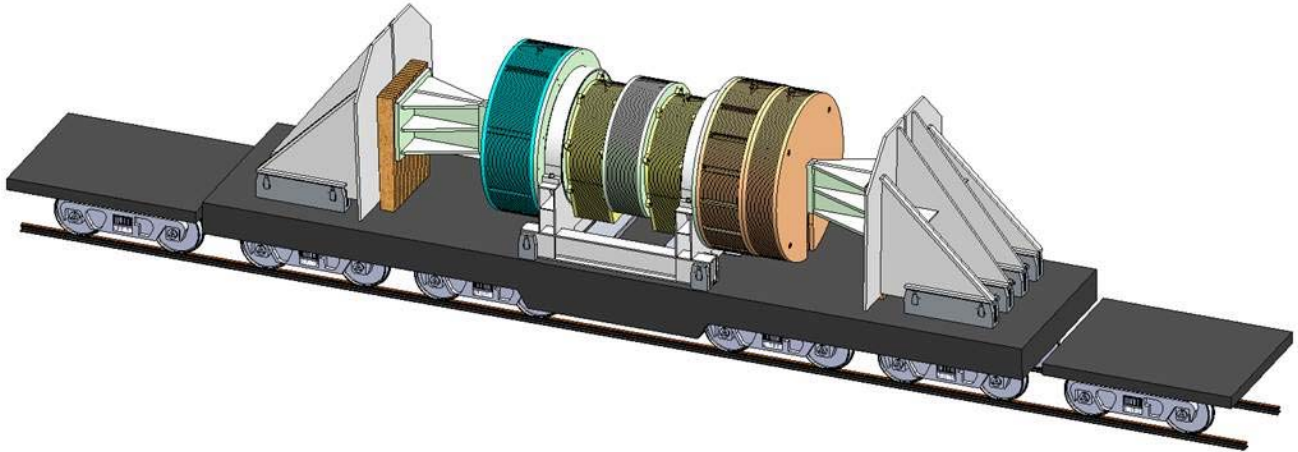

Note: Colors on test load are for illustration purposes only



7.0 OTHER INFORMATION

This section contains information related to changes discovered necessary in Phase 3 to the Family 1 conceptual cradle design developed in Phase 1 and used for modeling in Phase 2 of the HLRM prototype railcars project. Also, slight changes to the previously provided general loading procedures were made as a result of knowledge from the fabrication of the Atlas railcar's cradle attachment during Phase 3.

7.1 Changes to Conceptual Cradle Designs as a Result of Phase 3

The weight of the Atlas Railcar HI-STAR 60 conceptual cradle was miscalculated in CALC-3015133-002. The actual weight of the cradle is less than what was calculated and provided to the Transportation Technology Center, LLC (TTCI) in CALC-3015934-001 and CALC-3015276-003. The weight was corrected, resulting in changes to the conceptual cradle weight, center of gravity and mass moment of inertia; however, the corrected values remain within the bounding conditions of dynamic modelling inputs evaluated by TTCI. The HI-STAR 60 conceptual cradle design was also revised to add weight to ensure that the modeled parameters remained near the same; this was accomplished by simply increasing the size of the conceptual cradle design's pin blocks doubler plates.

When the error was identified, a Corrective Action Report (CAR) was initiated per the FS corrective action program and the affected calculations were revised. The CAR also included the action item to notify TTCI and provide the revised documents to TTCI for evaluation of impact. TTCI considered the changes and advised that there was no impact to the completed dynamic modeling results.

Enclosed in Appendix J.1 is a FS letter notifying the DOE COR of this situation, the resulting correction and copies of affected documents. Also included in Appendix J.2 is a letter to TTCI dynamic modeling subject matter expert Mr. Russ Walker notifying him of the potential impact to the Phase 2 dynamic modeling for the Family 1 conceptual cradle design. Mr. Walker's response that there is no impact is included in Appendix J.3.

7.1.1 HI-STAR 60 (Family 1) Conceptual Cradle Design Revision

The HI-STAR 60 conceptual cradle pin block doubler plates were revised to align the conceptual cradle weight with the dynamic modeling results. This revision is reflected in the revised calculation CALC-3015133-004 enclosed in Appendix J.4 and the revised drawing DWG-3015137-002 enclosed in Appendix J.5.

7.2 Changes to General Loading Procedures as a Result of Phase 3

The previously delivered Atlas Railcar General Loading Procedures were revised for two minor changes as a result of Phase 3 activities. These changes are discussed below.

7.2.1 Cleaning and Rust Prevention of Cradle Attachment Interface Pin Blocks

As discussed in Section 3.3.3, Kasgro and FS processed NCR #2 (see Section 4.2.3.1.6) allowing Kasgro to eliminate the stainless-steel cladding in the prototype railcar pin blocks. As the presence of the cladding is to aid in the prevention of rust over the life of the railcar, the general loading procedures were revised to include a cleaning and grease application to the internal channel of the end stop pin blocks to prevent excessive rusting in the absence of a protective cladding (see Appendix K, *Revised General Loading Procedures*, Section 6.0).



7.2.2 Angle of Tie Downs Used During Loading/Unloading

Clarification and an additional bullet were added to Section 2, page 9 of the general loading procedures to provide additional information stating that Atlas railcar tie-down brackets must be loaded in line with the brackets. This simple statement was added to ensure that Atlas railcar users in the field prevent potential damage to the brackets by using inappropriate tie-down points.



8.0 REFERENCES

- [1] Association of American Railroads, Manual of Standards and Recommended Practices, Section C, Car Construction Fundamentals and Details, Standard S-2043, Performance Specification for Trains Used to Carry High-Level Radioactive Material, 2017.
- [2] Association of American Railroads, Manual of Standards and Recommended Practices, Section C, Car Construction Fundamentals and Details, Standard S-2044, Safety Appliance Requirements for Freight Cars, 2017 and effective 01/12/2018
- [3] Association of American Railroads, Manual of Standards and Recommended Practices, Section C - Part II, Design, Fabrication and Construction of Freight Cars (M-1001), 2015.
- [4] Association of American Railroads, Manual of Standards and Recommended Practices, Section J, Specification for Quality Assurance, Specification M-1003, 2016.
- [5] Oak Ridge National Laboratories, AAR S-2043 Cask Railcar System Requirements Document, FCRD-NFST-2014-000093 Rev.1, ORNL/TM-2014/596, December 1, 2014.
- [6] Department of Energy Contract DE-NE0008390, latest revision, Part I, Section C, Statement of Work, Attachment A, Transport Cask Characteristics.
- [7] American Society of Mechanical Engineers (ASME), Standard Specification for Straight-Beam Ultrasonic Examination of Steel Plates, Standard SA-435, Book of Standards Volume 01.04, ASTM International, West Conshohocken, PA, 2017.
- [8] Association of American Railroads, 2015 Field Manual of the AAR Interchange Rules, Section C Requirements for Acceptance, Rule 88, 2015.
- [9] Association of American Railroads, Manual of Standards and Recommended Practices, Section C, Car Construction Fundamentals and Details, Standard 2028, Plate C – Equipment Diagram for Limited Interchange Service, 2013. (Note: This standard has been replaced by AAR Standard S-2056, see Reference # 33)
- [10] Association of American Railroads, Manual of Standards and Recommended Practices, Section C, Car Construction Fundamentals and Details, Standard 2029, Plate C-1 – Maximum Width of Cars with Curious Truck Centers, 2007. (Note: This standard has been replaced by AAR Standard S-2056, see Reference # 33)
- [11] Association of American Railroads, Manual of Standards and Recommended Practices, Section C, Car Construction Fundamentals and Details, Standard 2030, Plate D – Obtaining Maximum Allowable Width of Car, Other Than at Centerline of Car, For Unrestricted (Plate B-1) and Limited (Plates C-1, H-1, J-1, and K-1) Interchange Service, 2009. (Note: This standard has been replaced by AAR Standard S-2056, see Reference # 33)
- [12] Association of American Railroads, Manual of Standards and Recommended Practices, Section C, Car Construction Fundamentals and Details, Standard 2043, Performance Specification for Trains Used to Carry High-Level Radioactive Material, Section 4.7.9.1, Railcar Clearance Section, 2009.
- [13] Association of American Railroads, Manual of Standards and Recommended Practices, Section C, Car Construction Fundamentals and Details, Standard 2031, Plate E – Equipment Diagram for Limited Interchange Service, 2007. (Note: This standard has been replaced by AAR Standard S-



2056, see Reference # 33)

- [14] National Archives and Records Administration, Office of Federal Register, Code of Federal Regulations 60FR 50264, Title 49 – Transportation, Parts 200-299, 2016.
- [15] AREVA Federal Services, Quality Assurance Program Description, AFS-QA-PMD-001 Rev 3, November 15, 2013.
- [16] American Society of Mechanical Engineers, Nuclear Quality Assurance-1, Standard NQA-1-2008 and addendum NQA-1A-2009.
- [17] AREVA Federal Services, Project QA Plan, Design and Prototype Fabrication of Atlas Railcars for HLRM, QA-3014737-002, January 14, 2016.
- [18] Department of Energy Contract DE-NE0008390, latest revision, Part III – List of Documents, Exhibits and Other Attachments, Attachment J-C, Quality Assurance Surveillance Plan.
- [19] Kasgro Rail Corporation, Quality Assurance Manual for AAR Specification M-1003, Revision 29, December 14, 2015.
- [20] Association of American Railroads, Manual of Standards and Recommended Practices, Section E, Brakes and Brake Equipment, Standard S-471, Brake Pipe Restriction Test, February 2014.
- [21] Association of American Railroads, Manual of Standards and Recommended Practices, Section E, Brakes and Brake Equipment, Standard S-401, Brake Design Requirements, February 2014.
- [22] Association of American Railroads, Manual of Standards and Recommended Practices, Section C – Part II, Design, Fabrication, and Construction of Freight Cars, paragraph 5.4, Clearance Test – Truck, Car Body and Brake Rigging, 2015.
- [23] Association of American Railroads, Manual of Standards and Recommended Practices, Section E, Brakes and Brake Equipment, Standard S-486, Brake System Static Testing, February 2014.
- [24] Association of American Railroads, Manual of Standards and Recommended Practices, Section C, Car Construction Fundamentals and Details, Standard 2043, Performance Specification for Trains Used to Carry High-Level Radioactive Material, paragraph 5.3, Static Brake Tests, 2009.
- [25] American Welding Society, Standard AWS D15.1, Railroad Welding Specification for Cars and Locomotives, 5th Edition, April 18, 2012.
- [26] Association of American Railroads, Manual of Standards and Recommended Practices, Section C, Car Construction Fundamentals and Details, Standard 2043, Performance Specification for Trains Used to Carry High-Level Radioactive Material, paragraph 4.1.10, Weld Analysis, 2009.
- [27] Association of American Railroads, Manual of Standards and Recommended Practices, Section C, Car Construction Fundamentals and Details, Standard S-2044, Safety Appliance Requirements for Freight Cars, Appendix D-1, *Safety Appliances for Flatcars with Full Decks*, 2017 and effective 01/12/2018
- [28] National Archives and Records Administration, Office of Federal Register, Code of Federal Regulations Title 49. Transportation, Subtitle B. Other Regulations Relating to Transportation, Chapter II, Federal Railroad Administration, Department of Transportation, Part 224, Reflectorization of Rail Freight Rolling Stock, October 28, 2015.



- [29] National Archives and Records Administration, Office of Federal Register, Code of Federal Regulations Title 49. Transportation, Subtitle B. Other Regulations Relating to Transportation, Chapter II, Federal Railroad Administration, Department of Transportation, Part 231. Railroad Safety Appliance Standards, Section 231.18. Cars of Special Construction, December 25, 1968.
- [30] Lat-Lon, LLC, 2300 S. Jason Street, Denver, CO 80223, USA, webpage <http://lat-lon.com>.
- [31] Association of American Railroads, Field Manual of the AAR Interchange Rules, latest edition.
- [32] AREVA Federal Services, LLC, Design and Prototype Fabrication of Railcars for Transport of High-Level Radioactive Material, Phase 2: Preliminary Design, Contract DE-NE0008390, Revision 1, 03/06/2018, Appendix I, Engineering Information Record EIR-3019494-000 dated June 20, 2017
- [33] Association of American Railroads, Manual of Standards and Recommended Practices, Section C, Car Construction Fundamentals and Details, Standard 2056, Clearance Plate Diagrams for Interchange Service, 2017 (implemented by AAR Circular Letter C-12935 dated July 31, 2017).