



QA: QA

ANL-MGR-GS-000003 REV 03

September 2007

Number of Waste Packages Hit By Igneous Events

Prepared for:
U.S. Department of Energy
Office of Civilian Radioactive Waste Management
Office of Repository Development
1551 Hillshire Drive
Las Vegas, Nevada 89134-6321

Prepared by:
Sandia National Laboratories
OCRWM Lead Laboratory for Repository Systems
1180 Town Center Drive
Las Vegas, Nevada 89144

Under Contract Number
DE-AC04-94AL85000

DISCLAIMER

This report was prepared as an account of work sponsored by an agency of the United States Government. Neither the United States Government nor any agency thereof, nor any of their employees, nor any of their contractors, subcontractors or their employees, makes any warranty, express or implied, or assumes any legal liability or responsibility for the accuracy, completeness, or any third party's use or the results of such use of any information, apparatus, product, or process disclosed, or represents that its use would not infringe privately owned rights. Reference herein to any specific commercial product, process, or service by trade name, trademark, manufacturer, or otherwise, does not necessarily constitute or imply its endorsement, recommendation, or favoring by the United States Government or any agency thereof or its contractors or subcontractors. The views and opinions of authors expressed herein do not necessarily state or reflect those of the United States Government or any agency thereof.

QA: QA

Number of Waste Packages Hit By Igneous Events

ANL-MGR-GS-000003 REV 03

September 2007



Scientific Analysis/Calculation Signature Page/Change History

Page iii

1. Total Pages: 134

Complete only applicable items.

2. Document Title Number of Waste Packages Hit by Igneous Events			
3. DI (Including Revision No. and Addendum No.) ANL-MGR-GS-000003 REV03			
	Printed Name	Signature	Date
4. Originator	Michael Wallace	<i>Michael A. Wallace</i>	9-28-07
5. Checker	Donathan Krier	<i>Donathan Krier</i>	10/1/07
6. QCS/Lead Lab QA Reviewer	Sounia Kassabian-Darnell	<i>Sounia K. Darnell</i>	10/01/2007
7. Responsible Manager/Lead	Gregory Valentine	<i>G. Valentine</i>	1 Oct 07
8. Responsible Manager	Thomas Pfeifle	<i>Thomas Pfeifle</i>	10/1/07
9. Remarks			
Change History			
10. Revision No.	11. Description of Change		
REV 00	Initial issue. This analysis extensively utilizes a new computer code to explicitly compute intersections of the repository design with igneous features.		
REV 01	The document was revised to include the latest backfill analysis, repository layout, sensitivity studies on dike spacing, and management approved recommendations from the evaluation phase of the Regulatory Integration Team. These comments focused on regulatory implications, transparency, and traceability.		
REV 02	Document was revised to incorporate dike drift proximity factors (through a new Appendix G) that address CR 3891. Document includes more comprehensive ranges for core dike widths and dike spacings. As a result of the new dike spacing range, the dike spacing sensitivity analysis (Section 6.5) from the previous revision has been eliminated in this revision. This revision also provides closure of TBVs, updates references to project documents as appropriate, and contains an updated Appendix E.		

REV 03

For this Rev 0C, the entire model documentation was revised because the changes were too extensive. Therefore change bars are not used.

Document and analyses reflect updates to igneous parameter input ranges, as well as updates to repository design. Document includes new treatment of conduit-repository intersection. Document and analyses reflect removal of an assumption concerning the ability of the repository configuration to impede magma flow between emplacement drifts, in the event of a dike intrusion. This document also addresses Condition Report CR 6194 by changing the word 'intrusion' to 'event' on the title page.

ACKNOWLEDGEMENTS

Contributors to this report include Branko Damjanic and Terry Crump.

INTENTIONALLY LEFT BLANK

CONTENTS

	Page
ACKNOWLEDGEMENTS.....	v
ACRONYMS.....	xiii
1. PURPOSE.....	1-1
2. QUALITY ASSURANCE.....	2-1
3. SOFTWARE.....	3-1
4. DIRECT INPUTS.....	4-1
4.1 PARAMETERS/DATA.....	4-1
4.2 CRITERIA.....	4-5
4.3 CODES, STANDARDS, AND REGULATIONS.....	4-5
5. ASSUMPTIONS.....	5-1
5.1 MAGMA FLOODING OF REPOSITORY FROM AN IGNEOUS INTRUSION	5-1
5.2 INTERSECTIONS OF CONDUITS WITH REPOSITORY	5-1
5.3 MINIMUM SPACING BETWEEN CONDUITS.....	5-2
5.4 CONDUITS ASSIGNED ALONG A SINGLE DIKE.....	5-2
5.5 ROCK DILATION ANGLE.....	5-3
6. DISCUSSION.....	6-1
6.1 ANALYSIS OBJECTIVES.....	6-1
6.2 FEATURES, EVENTS, AND PROCESSES INCLUDED IN THE ANALYSIS	6-1
6.3 ANALYSIS.....	6-2
6.3.1 Repository Geometry.....	6-3
6.3.2 Igneous Intrusive and Eruptive Analyses	6-3
6.3.3 Use of DIRECT Software to Produce Preliminary Results	6-11
6.3.4 Screening Logic and Subsequent Final Development Steps.....	6-16
6.4 UNCERTAINTY.....	6-18
6.4.1 Repository Design Uncertainties	6-18
6.4.2 Epistemic Igneous Uncertainties.....	6-18
6.4.3 Numerical Uncertainties	6-21
7. CONCLUSIONS.....	7-1
7.1 SUMMARY.....	7-1
7.2 ANALYSIS OUTPUT AND RATIONALE	7-1
7.3 PARAMETER VALUES.....	7-2
7.4 DTN/NAME OR OTHER REFERENCE.....	7-2
8. REFERENCES.....	8-1
8.1 DOCUMENTS CITED.....	8-1
8.2 CODES, STANDARDS, REGULATIONS, AND PROCEDURES.....	8-3

CONTENTS (Continued)

	Page
8.3 SOURCE DATA, LISTED BY DATA TRACKING NUMBER	8-3
8.4 SOFTWARE CODES	8-4
8.5 PRODUCT OUTPUT, LISTED BY DATA TRACKING NUMBER	8-4
APPENDIX A: PREPROCESSING TO DIRECT CODE	A-1
APPENDIX B: OUTPUT DEVELOPMENT DETAILS	B-1
APPENDIX C: DESCRIPTION OF MINOR INPUT DISCREPANCIES	C-1
APPENDIX D: INTERMEDIATE STEPS IN THE DEVELOPMENT OF DIRECT SIMULATIONS	D-1
APPENDIX E: APPLICABLE YMRP ACCEPTANCE CRITERIA	E-1
APPENDIX F: GLOSSARY	F-1
APPENDIX G: CRITICAL DISTANCE ANALYSIS	G-1

FIGURES

	Page
4-1. Data Processing Flow for Waste Packages Hit Analysis	4-4
5-1. Illustration of Eruptive Conduit "Cookie Cutter" Treatment	5-2
6-1. Overlay of DIRECT V. 4.0 Representation of Repository onto Repository Design.....	6-4
6-2. Spatial Distribution of Expected Volcanic Event Frequency.....	6-5
6-3. General Coverage in Which Dike Swarms Can Be Centered and Conceivably Intersect the Repository.....	6-6
6-4. Sampled Dike Swarm Centroids	6-8
6-5. Example of a Dike – Drift 'Hit' Case Caused by Halo Intersection with Emplacement Drift	6-10
6-6. Sample DIRECT V. 4.0 Output, Replicate 03, Set 679, Remote View	6-13
6-7. Sample DIRECT V. 4.0 Output, Replicate 03, Set 679, Standard View	6-14
6-8. Sample DIRECT V. 4.0 Output, Replicate 03, Set 679, Detail.....	6-15
6-9. Sample DIRECT V. 4.0 Output, Replicate 03, Set 679, Detail of Conduit—Drift Intersection	6-16
7-1. Number of Waste Packages Hit, Intrusive Compliance Case	7-1
7-2. Number of Waste Packages Hit by Eruptive Conduits	7-2
A-1. Description of <i>lhs.dat</i> Input File to DIRECT	A-6
G-1. Conditions of Dike Propagation in the Vicinity of the Drift.....	G-2
G-2. Stages 0, 1, 2, and 3 Considered in the Calculation of Mechanical Interaction between Dike and Drift	G-4
G-3. Characteristics of the FLAC Mesh Used in the Analysis.....	G-5
G-4. Distribution of Lithophysal Porosity Abundance (Frequency) for the Tptpl in the ECRB Cross-Drift	G-6
G-5. Extent of Plastic Zone for Stage 1 (After Excavation of the Drift) for Rock Mass Category 1 and Perfectly Plastic Behavior.....	G-9
G-6. Extent of Plastic Zone for Stage 2 (Rock Mass Category 1 and Perfectly Plastic Behavior) in the Case $d/2R = 2.0$	G-10
G-7. Extent of Plastic Zone for Stage 2 (Rock Mass Category 1 and Perfectly Plastic Behavior) in the Case $d/2R = 1.0$	G-10
G-8. Extent of Plastic Zone for Stage 2 (Rock Mass Category 1 and Perfectly Plastic Behavior) in the Case $d/2R = 0.5$	G-11
G-9. Extent of Plastic Zone for Stage 2 (Rock Mass Category 1 and Perfectly Plastic Behavior) in the Case $d/2R = 0.25$	G-11
G-10. Extent of Plastic Zone for Stage 2 (Rock Mass Category 1 and Perfectly Plastic Behavior) in the Case $d/2R = 0.10$	G-12
G-11. Extent of Plastic Zone for Stage 2 (Rock Mass Category 1 and Perfectly Plastic Behavior) in the Case $d/2R = 0.05$	G-12
G-12. Extent of Plastic Zone for Stage 3 (Rock Mass Category 1 and Perfectly Plastic Behavior) in the Case $d/2R = 2.0$	G-13
G-13. Extent of Plastic Zone for Stage 3 (Rock Mass Category 1 and Perfectly Plastic Behavior) in the Case $d/2R = 1.0$	G-14

FIGURES (Continued)

	Page
G-14. Extent of Plastic Zone for Stage 3 (Rock Mass Category 1 and Perfectly Plastic Behavior) in the Case $d/2R = 0.5$	G-15
G-15. Extent of Plastic Zone for Stage 3 (Rock Mass Category 1 and Perfectly Plastic Behavior) in the Case $d/2R = 0.25$	G-16
G-16. Extent of Plastic Zone for Stage 3 (Rock Mass Category 1 and Perfectly Plastic Behavior) in the Case $d/2R = 0.10$	G-17
G-17. Extent of Plastic Zone for Stage 3 (Rock Mass Category 1 and Perfectly Plastic Behavior) in the Case $d/2R = 0.05$	G-18
G-18. Extent of Plastic Zone for Stage 3, Lateral Pressure 8 MPa, in the Case $d/2R = 0.5$ (Rock Mass Category 3 and Brittle Behavior with 50 Percent Reduction of Cohesion).....	G-20
G-19. Extent of Plastic Zone for Stage 3, Lateral Pressure 8MPa, in the Case $d/2R = 0.25$ (Rock Mass Category 3 and Brittle Behavior with 50 Percent Reduction of Cohesion).....	G-20
G-20. Extent of Plastic Zone for Stage 3, Lateral Pressure 8MPa, in the Case $d/2R = 0.25$ (Rock Mass Category 5 and Brittle Behavior with 50 Percent Reduction of Cohesion).....	G-21
G-21. Extent of Plastic Zone for Stage 3, Lateral Pressure 8MPa, in the Case $d/2R = 0.10$ (Rock Mass Category 5 and Brittle Behavior with 50 Percent Reduction of Cohesion).....	G-21

TABLES

	Page
3-1. Software Used in Analysis	3-1
4-1. Direct Inputs to Analysis	4-1
6-1. Included FEPs for this Report	6-2
6-2. Summary of Selected Igneous and Related Parameter Inputs for Set 679 of Replicate 03	6-11
6-3. Screening Criteria Information for Output from DIRECT V. 4.0 Runs	6-17
6-4. Number of Waste Packages Hit by Eruptive Conduits as a Function of Replicate Number	6-21
6-5. Eruptive Center Probability Calculated by Replicate Subpopulation	6-21
7-1. TSPA Parameters for Number of Waste Packages Hit	7-3
A-1. The Seven Worksheets of <i>DikeSeeds_07.xls</i>	A-4
B-1. DIRECT V4.0 Output Files	B-1
B-2. The Four Worksheets of <i>ResultsPrelimCase0#d.xls</i>	B-3
G-1. Mechanical Properties for Rock Mass Categories	G-7
G-2. Stability Conditions Obtained with FLAC for the Pillar between the Dike and the Drift for Rock Mass Category 1 and Perfectly Plastic Behavior	G-9
G-3. Stability Conditions Obtained with FLAC for the Pillar between the Dike and the Drift for Rock Mass Category 3 and Perfectly Brittle Behavior, with Residual Cohesion 50 Percent of the Peak Cohesion	G-19
G-4. Stability Conditions Obtained with FLAC for the Pillar between the Dike and the Drift for Rock Mass Category 5 and Perfectly Brittle Behavior, with Residual Cohesion 50 Percent of the Peak Cohesion	G-19
G-5. Calculated Critical Distances for Different Categories of Lithophysal Rock Mass	G-23

INTENTIONALLY LEFT BLANK

ACRONYMS

AMR	analysis and model report
CDF	cumulative distribution function
DIRS	Document Input Reference System
DTN	data tracking number
ECP	eruptive center probability
ECRB	Enhanced Characterization of the Repository Block (Cross Drift)
FEPs	features, events, and processes
LHS	Latin Hypercube Sampling (code)
NRC	U.S. Nuclear Regulatory Commission
NSP	Nevada state plane
TGE	Torque Game Engine
TSPA	total system performance assessment
TWP	technical work plan
UTM	universal transverse Mercator
YMRP	<i>Yucca Mountain Review Plan, Final Report</i>

INTENTIONALLY LEFT BLANK

1. PURPOSE

The purpose of this report is to document calculations of the number of waste packages that could be damaged in a potential future igneous event intersecting a repository at Yucca Mountain. The analyses include disruption from an igneous intrusion and from an igneous eruption. The analyses also support the evaluation of the potential consequences from a future event as part of the total system performance assessment (TSPA) for the license application for the Yucca Mountain Project.

Igneous activity is a disruptive event included in the TSPA analyses because the annual local probability of occurrence is greater than 1×10^{-8} (BSC 2004 [DIRS 169989], Table 7-1). Two igneous activity scenarios are considered:

- The igneous intrusion groundwater release scenario (also called the igneous intrusion scenario) considers in situ damage to waste packages or failure of waste packages that occurs if they are engulfed by magma as a result of an igneous intrusion.
- The igneous eruption (also called volcanic eruption) scenario depicts the direct release to the biosphere of radioactive waste due to an intrusion intersecting the repository followed by a volcanic eruption at the surface.

An igneous intrusion is defined as the ascent of a basaltic dike or dike system (i.e., a set or swarm of multiple dikes comprising a single intrusive event) to repository level, where the dike or dikes intersect drifts. Magma reaching the surface from an igneous event is an eruption (or extrusive activity) (Jackson 1997 [DIRS 109119], pp. 224 and 333).

The work documented in this report is an exploration of plausible intersections between the repository and dike swarm configurations. The work utilizes standard calculations and engineering techniques. Although the code DIRECT (V. 4.0. STN: 11121-4.0-00 [DIRS 179574]) was updated for this effort, all of its results are reproducible through simple hand or spreadsheet calculations (as was true for all revisions of this code). Accordingly, this work is classified as a scientific analysis, under the definition found in SCI-PRO-005, *Scientific Analyses and Calculations*.

This analysis leads to the development of outputs of the number of waste packages that could be affected by each of the two igneous scenarios. In addition, this analysis develops a third parameter, which relates the frequency of eruptive events to the frequency of intrusive events.

This analysis follows *Technical Work Plan for: Igneous Activity Assessment for Disruptive Events* (SNL 2007 [DIRS 182219], Section 1.2.4). Table 1-5 of this technical work plan (TWP) summarizes the activities intended to be performed for this analysis.

Following Section 2.2.2.8 of the TWP, this analysis closes SPR 002220050816, a Software Problem Report that documented an error (now corrected) affecting the representation of dike swarms in a small number of software runs supporting the previous revision of this analysis. This analysis also addresses the condition report CR 6194, by changing the word "intrusion" in the report title to "events"; however, in so doing, it does not impact any previous revision of this report.

2. QUALITY ASSURANCE

The results of this report are important to the demonstration of compliance with the postclosure performance objectives prescribed in 10 CFR 63.113 [DIRS 180319]. The analyses are controlled by approved procedures subject to the Yucca Mountain Project quality assurance program, as documented in Section 8.1 of the relevant TWP (SNL 2007 [DIRS 182219]). The conduct of quality activities described in this report is also documented in that TWP. This report was developed under SCI-PRO-005, *Scientific Analyses and Calculations*.

This report documents calculations of the number of waste packages that could be damaged by a potential future igneous event through a repository at Yucca Mountain. Development of this report and supporting analyses are subject to *Quality Assurance Requirements Document* (DOE 2007 [DIRS 182051]). The electronic management of data was accomplished in accordance with the controls specified in the TWP (SNL 2007 [DIRS 182219], Section 8.5 and the Lead Laboratory procedure IM-PRO-002, *Control of the Electronic Management of Information*

INTENTIONALLY LEFT BLANK

3. SOFTWARE

This analysis uses both qualified and exempt software. The qualification status of the software is indicated in the electronic Document Input Reference System (DIRS) database and in the Software Configuration Management System Baseline Report. All software was obtained from Software Configuration Management and is appropriate for the application. Qualified codes were used only within the range of validation, as required by IM-PRO-003, *Software Management*, the procedure governing software use.

All software of either type is controlled by Software Configuration Management. Unless otherwise stated, all software described in this section was run within a Windows XP operating system.

The software codes used in this analysis are described in Table 3-1. The table is divided into two sections. The top section covers the four qualified codes. The bottom section covers the four exempt codes.

Table 3-1. Software Used in Analysis

Software Title and Version	Software Tracking Number (STN)	Summary of Code Usage	Computer: Type and Platform
QUALIFIED SOFTWARE			
LHS V. 2.51	10205-2.51-00 [DIRS 167794]	Stochastic parameter sampling	DEC Alpha, with Open VMS AXP V. 7.3-1 operating system
DIRECT V. 4.0	11121-4.0-00 [DIRS 179574])	Geometric intersection calculations	PC running Windows XP operating system
FLAC V. 4.0	10167-4.0-00 [DIRS 161953])	Dike/drift proximity calculations	PC running Windows 2000 operating system
CORPSCON V. 5.11.08	10547-5.11.08-00 [DIRS 155082]	Conversion of UTM to NSP coordinates	PC running Windows 2000 operating system
EXEMPT SOFTWARE			
Microsoft Excel 2000 (9.0.5121 SR-1)	NA	Standard spreadsheet calculations	PC running Windows XP operating system
VULCAN V. 6.0	NA	Standard CAD applications	PC running Windows XP operating system
Rhinoceros (also called Rhino 3D in text) V. 3.0	NA	Standard CAD applications	PC running Windows XP operating system
Milkshape 3D V. 1.8.1b	NA	Standard CAD applications	PC running Windows XP operating system

NOTE: NSP = Nevada state plane; UTM = universal transverse Mercator.

Computer code LHS (for Latin Hypercube Sampling) (V. 2.51. STN: 10205-2.51-00 [DIRS 167794]) is a qualified FORTRAN code that provides a method to simultaneously "bin" multiple parameter distributions for use by subsequent models or calculations.¹ The LHS technique is used for this binning method. A general treatment of the LHS method upon which the computer code is based can be found in *Latin Hypercube Sampling and the Propagation of*

¹ Parameter distributions are often described simply by ranges and descriptors, such as the mean or standard deviation. To be incorporated into a numerical analysis such as is contained in this document, those distributions have to be converted into a discretized version. Each discrete interval produced is considered to be a "bin."

Uncertainty in Analyses of Complex Systems (Helton and Davis 2002 [DIRS 163475]). This technique approximates the Monte Carlo method, employing stratified sampling, without missing representative distribution tail values. For this analysis, LHS was used to develop a distribution of realizations of the required input parameters (as described in Sections 4 and 6).

LHS was used within its intended purposes and its range of validation. LHS was run on a DEC Alpha microprocessor with the Open VMS AXP V. 7.3-1 operating system. The software was selected because it was suitable for the tasks of binning multiple parameter distributions and combining them. No alternate software programs were found offering superior performance.

Computer code DIRECT V 4.0 (STN: 11121-4.0-00 [DIRS 179574]) is a qualified geometric analysis package written using Torque Game Engine (TGE), which is a commercial open-source software development kit employing C++ coding and a separate scripting language. For this analysis (specific to igneous-repository intersections only), DIRECT can incorporate "binned" probability distributions of igneous parameters into calculations of the numbers of waste packages hit. DIRECT was used within its intended purposes and its range of validation. DIRECT was run on a PC workstation using the Windows XP operating system. The software was selected for modification and use because it is suitable for the tasks of calculating intersections between igneous features and repository drifts, and for detailed examination of the results. A general search of alternate commercial off-the-shelf software was conducted, and no alternates were found to be capable of performing these specific custom tasks.

Limitations are applied to the LHS and DIRECT codes as follows:

- The LHS code automatically truncates any normal distribution to the 1st and 99th percentiles, but it cannot further process any user-defined truncation of distributions. A number of distributions used in this analysis have limits requiring truncation. Therefore, those truncations are performed in later steps and described where relevant.
- When run in automatic mode with the default number of dike sets (~1,000), DIRECT produces a diagnostic log file (*console.log*), which may exceed 5 MB in size. This file supports full verification of any and all intersection cases. The PC that is employed for execution of DIRECT should have sufficient disk capacity to enable this log file to be produced.
- DIRECT fails to properly calculate dike-drift intersections when the dike azimuth value is sufficiently close to zero. However, DIRECT produces the output file, "*DikeAzFail.txt*," which flags all of these cases. Those cases are then removed in a postprocessing step. This is described in more detail in Section 6.3.4.

The qualified computer code FLAC V. 4.0 (STN: 10167-4.0-00 [DIRS 161953]) is a finite element continuum mechanics code that was used in Appendix G of this report to help develop values for the table of dike proximity factors. FLAC was used for its intended purposes and within its range of validation. FLAC was run on a PC platform using the Windows 2000 operating system.

The qualified computer code CORPSCON V. 5.11.08 (STN: 10547-5.11.08-00 [DIRS 155082]) was used to convert universal transverse Mercator (UTM) coordinates to Nevada state plane (NSP) coordinates in support of this analysis. The software was selected both because it was suitable for that task and the input data was suitable for use by this software. CORPSCON was run on a Windows 2000 operating system.

Only standard Excel functions were used in the calculations prepared using Microsoft Excel 2000. However, a single macro was used for a repeated task of deleting a row and shifting lower cells up. Electronic output files from Excel are included as Appendices A and B, and use of the macro is documented in each worksheet in which it was used.

In a prototyping and scoping effort, the mining engineering/design software code VULCAN V. 6.0 was used to view in detail, via zooming and panning, the geometry of selected turnouts to emplacement drifts.

Rhino 3D was used in a preprocessing step to produce initial block shapes, which ultimately feed to DIRECT and are used to represent geometric features.

Milkshape 3D was used in a follow-on step to Rhino 3D, to produce "shapefiles" based on the initial block shapes. These were then replicated, extruded, rotated, and translated to represent each drift, dike, and conduit segment, as well as to represent the background grid, the repository perimeter, and additional geometric indicators for the dike swarm.

INTENTIONALLY LEFT BLANK

4. DIRECT INPUTS

4.1 PARAMETERS/DATA

The parameters/data direct inputs used for the analyses are described in this section and listed in Table 4-1. Figure 4-1 is a flowchart that maps the flow of data from qualified inputs to the outputs of this analysis. The data flow generally corresponds to the five steps listed at the beginning of Section 6.3.

Inputs can be divided into two main categories: repository design and igneous parameters. Repository design parameters include emplacement drift locations, turnout locations, drift extensions, and boundaries. The design information is extracted from *Total System Performance Assessment Data Input Package for Requirements Analysis for Subsurface Facilities* (SNL 2007 [DIRS 179466]).

Igneous parameters include dike swarm features and conduit features. Updates to these parameters include a sampling of dike swarm centroid locations, new distributions for dike length, dike azimuth, dike spacing, conduit size, and number of conduits. The reports associated with the sources for most of the igneous parameter updates are *Characterize Eruptive Processes at Yucca Mountain, Nevada* (SNL 2007 [DIRS 174260]), and *Characterize Framework for Igneous Activity at Yucca Mountain, Nevada* (BSC 2004 [DIRS 169989]).

Some parameters, such as minimum spacing between conduits, and rock dilation angle are developed in Section 5.

Table 4-1. Direct Inputs to Analysis

Input Information	Input Information Source	Value, Type, or Form
Repository Design Inputs		
1. Drift layout	SNL 2007 [DIRS 179466], Table 4-1, item 01-02	Graphical
2. Emplacement drift coordinates	SNL 2007 [DIRS 179466], Table 4-1, item 01-02; also see Appendix C of this report	Table of values
3. Geometry of drift turnouts and extensions	SNL 2007 [DIRS 179466], Table 4-1, item 01-02	Graphical
4. Drift spacing and diameter	SNL 2007 [DIRS 179466], Table 4-1, items 01-13 and 01-10, respectively	81-m spacing (between drift center lines) 5.5-m diameter
5. Planned total number of waste packages	DTN: MO0702PASTREAM.001 [DIRS 179925], Cell L-49 of "UnitCell" tab of spreadsheet: <i>DTN-Inventory-Rev00.xls</i>	11,629
6. Total number of active (non- contingency) drifts	SNL 2007 [DIRS 179466], Table 4-1, item 01-02	108
7. Total length of emplacement drifts	SNL 2007 [DIRS 179466], Table 4-1, item 01-02	65,273 m This number has subsequently been adjusted, as discussed in Section 6.3.1
8. Uncertainty in repository coordinates	SNL 2007 [DIRS 179466], Table 4-1, item 01-02	±10 m

Table 4-1. Direct Inputs to Analysis (Continued)

Input Information	Input Information Source	Value, Type, or Form																																						
Igneous Inputs—First Branch: Dike Swarm Seed Locations and Frequencies																																								
9. Dike swarm seed locations and frequencies	DTN: LA0009FP831811.001 [DIRS 164712], file: <i>CFRACSM.XY</i> (in <i>Dtn21.zip</i>)	Table of discrete probabilities associated with a regularly spaced coordinate grid																																						
Igneous Inputs—Second Branch: Geometric and Quantitative Characteristics of the Dike Swarm and Associated Eruptive Conduits																																								
10. Dike azimuth angles	DTN: LA0612DK831811.001 [DIRS 179987], file: <i>LA0612DK831811_001.xls</i> , Table 6-7	<table border="0"> <tr> <td>Azimuth (degrees clockwise from north)</td> <td>Probability (all sum to 1)</td> </tr> <tr> <td>0 to 009</td> <td>0.130</td> </tr> <tr> <td>010 to 019</td> <td>0.120</td> </tr> <tr> <td>020 to 029</td> <td>0.100</td> </tr> <tr> <td>030 to 039</td> <td>0.090</td> </tr> <tr> <td>040 to 049</td> <td>0.070</td> </tr> <tr> <td>050 to 059</td> <td>0.050</td> </tr> <tr> <td>060 to 069</td> <td>0.030</td> </tr> <tr> <td>070 to 079</td> <td>0.020</td> </tr> <tr> <td>080 to 089</td> <td>0.020</td> </tr> <tr> <td>090 to 099</td> <td>0.010</td> </tr> <tr> <td>100 to 109</td> <td>0.005</td> </tr> <tr> <td>110 to 119</td> <td>0.005</td> </tr> <tr> <td>120 to 129</td> <td>0.005</td> </tr> <tr> <td>130 to 139</td> <td>0.005</td> </tr> <tr> <td>140 to 149</td> <td>0.030</td> </tr> <tr> <td>150 to 159</td> <td>0.070</td> </tr> <tr> <td>160 to 169</td> <td>0.110</td> </tr> <tr> <td>170 to 179</td> <td>0.130</td> </tr> </table>	Azimuth (degrees clockwise from north)	Probability (all sum to 1)	0 to 009	0.130	010 to 019	0.120	020 to 029	0.100	030 to 039	0.090	040 to 049	0.070	050 to 059	0.050	060 to 069	0.030	070 to 079	0.020	080 to 089	0.020	090 to 099	0.010	100 to 109	0.005	110 to 119	0.005	120 to 129	0.005	130 to 139	0.005	140 to 149	0.030	150 to 159	0.070	160 to 169	0.110	170 to 179	0.130
Azimuth (degrees clockwise from north)	Probability (all sum to 1)																																							
0 to 009	0.130																																							
010 to 019	0.120																																							
020 to 029	0.100																																							
030 to 039	0.090																																							
040 to 049	0.070																																							
050 to 059	0.050																																							
060 to 069	0.030																																							
070 to 079	0.020																																							
080 to 089	0.020																																							
090 to 099	0.010																																							
100 to 109	0.005																																							
110 to 119	0.005																																							
120 to 129	0.005																																							
130 to 139	0.005																																							
140 to 149	0.030																																							
150 to 159	0.070																																							
160 to 169	0.110																																							
170 to 179	0.130																																							
11. Dike lengths	DTN: LA0612DK831811.001 [DIRS 179987], file: <i>LA0612DK831811_001.xls</i> , Table 7-1	Normal distribution, mean of 2 km, 95th percentile of 6 km, lower truncation at 0.4 km, upper truncation at 8 km.																																						
12. Dike thickness ("width" as used in cited document) at repository depth	DTN: LA0612DK831811.001 [DIRS 179987], file: <i>LA0612DK831811_001.xls</i> , Table 7-1	Normal distribution, mean of 8 m, 95th percentile value of 12 m. Lower truncation at 1 m.																																						
13. Number of dikes in a swarm	DTN: LA0612DK831811.001 [DIRS 179987], file: <i>LA0612DK831811_001.xls</i> , Table 7-1	Discrete Probabilities (sum to 1): One dike, 0.40 Two dikes, 0.25 Three dikes, 0.15 Four dikes, 0.10 Five dikes, 0.10																																						
14. Dike spacing (edge to edge)	DTN: LA0612DK831811.001 [DIRS 179987], file: <i>LA0612DK831811_001.xls</i> , Table 7-1	Random uniform distribution Minimum = 0.5 m Maximum = 1,500 m																																						

Table 4-1: Direct Inputs to Analysis (Continued)

Input Information	Input Information Source	Value, Type, or Form
15. Number of volcanic conduits at repository depth	DTN: LA0612DK831811.001 [DIRS 179987], file: LA0612DK831811_001.xls, Table 7-1	Discrete Probabilities (sum to 1): One conduit, 0.85 Two conduits, 0.10 Three conduits, 0.05
16. Volcanic conduit diameter at repository depth	DTN: LA0612DK831811.001 [DIRS 179987], file: LA0612DK831811_001.xls, Table 7-1	Normal distribution, mean = 15 m, 95th percentile = 21 m, lower truncation at 1 m. In addition, diameter cannot be less than the width of the parent dike chosen for each realization.
Magma—Repository Interaction Inputs		
17. Rock mass properties	DTN: MO0408MWDDDMIO.002 [DIRS 171483], \calculation files\Material Property, file: <i>Rock Mass Strength v2.xls</i> , folder: Lithophysal Rock	Table of mechanical properties (cohesion, friction, bulk modulus, and shear modulus) of three rock-mass categories
18. Rock thermal conductivity	DTN: SN0404T0503102.011 [DIRS 169129], Table 7-10)	1.28 W/mK
19. Rock specific heat	DTN: SN0402T0503102.010 [DIRS 170993], file <i>SN_new_DTN.xls</i>	985 J/kgK
20. Rock density	DTN: SN0404T0503102.011 [DIRS 169129], Table 7-10	1,979 kg/m ³
21. Lithophysal porosity	DTN: MO0408MWDDDMIO.002 [DIRS 171483], \Calculation Files\Material property\Lith porosity\Drift Deg AMR AF T-A-P Fit V1.xls, worksheet "Volume Percent - Stats," cells L20 to L206	Table of values

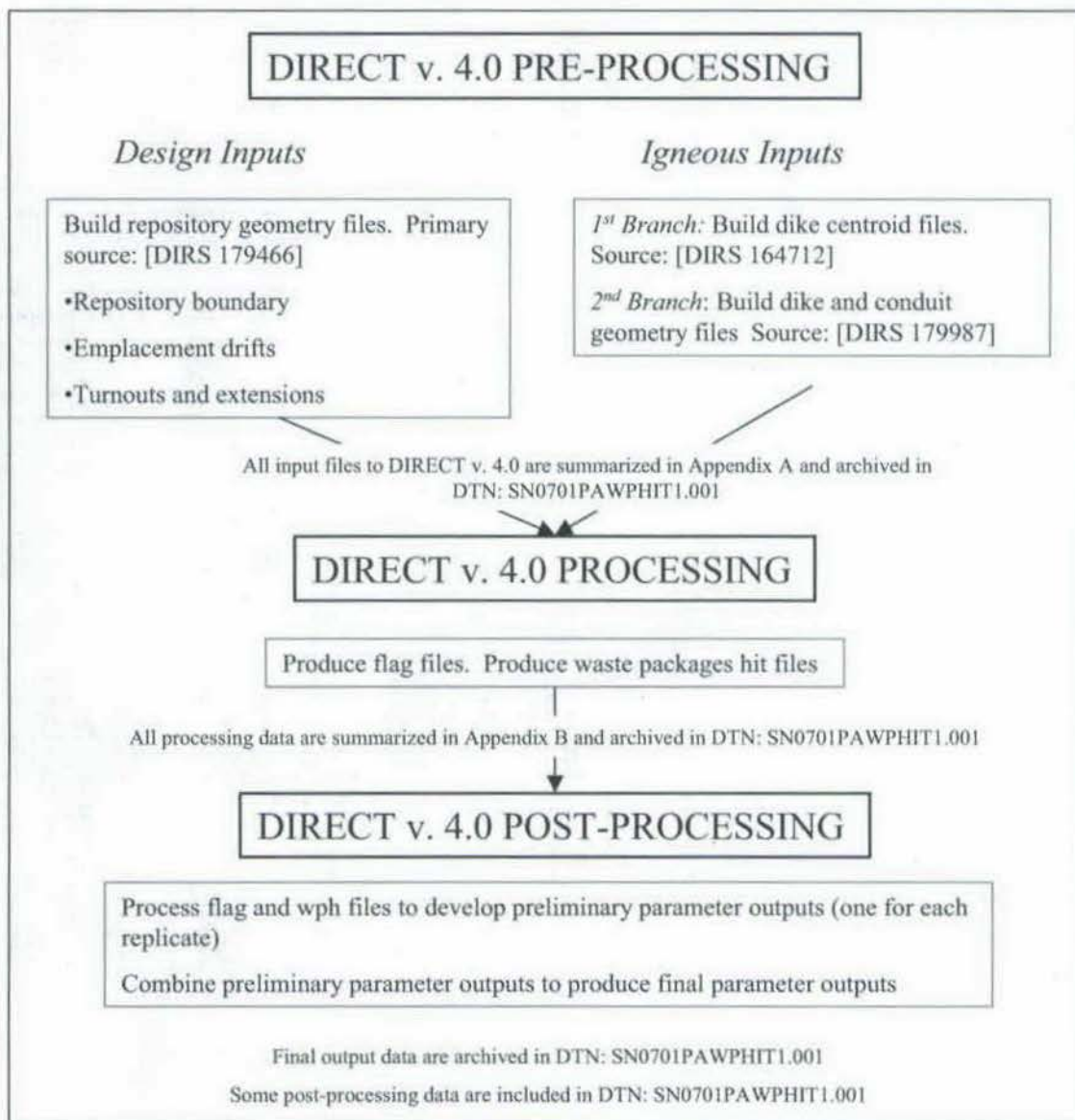

Source: All sources described within figure.

NOTE: wph = waste package hit.

Figure 4-1. Data Processing Flow for Waste Packages Hit Analysis

4.2 CRITERIA

The general requirements to be satisfied by the TSPA are stated in 10 CFR 63.114 [DIRS 180319]. The acceptance criteria that will be used by the U.S. Nuclear Regulatory Commission (NRC) to determine whether the technical requirements for the LA have been met are identified in *Yucca Mountain Review Plan, Final Report* (YMRP) (NRC 2003 [DIRS 163274]). This analysis constitutes a subcomponent of the TSPA, and the pertinent requirements and criteria for this report are summarized in Appendix E.

This report provides documentation that acceptance criteria described in the YMRP (NRC 2003 [DIRS 163274], Sections 2.2.1.3.2.3, 2.2.1.3.10.3, and 2.2.1.3.11.3) have been addressed. YMRP acceptance criteria associated with the integrated subissue of "Mechanical Disruption of Engineered Barriers" (NRC 2003 [DIRS 163274], Section 2.2.1.3.2.3) are intended to ensure the requirements of 10 CFR 63.114(a)-(c) and (e)-(g) [DIRS 180319] have been met. Descriptions of information in this report addressing acceptance criteria associated with the integrated subissue of "Mechanical Disruption of Engineered Barriers" are provided in Appendix E.

Similarly, YMRP acceptance criteria associated with the report's integrated subissue of "Volcanic Disruption of Waste Packages" (NRC 2003 [DIRS 163274], Section 2.2.1.3.10.3) are intended to ensure that the requirements at 10 CFR 63.114(a)-(c) and (e)-(g) [DIRS 180319] are met. Descriptions of how information in this report addresses the acceptance criteria associated with the integrated subissue of "Volcanic Disruption of Waste Packages" are provided in Appendix E.

Finally, YMRP acceptance criteria associated with the report's integrated subissue of "Airborne Transport" (NRC 2003 [DIRS 163274], Section 2.2.1.3.11.3) are intended to ensure that the requirements at 10 CFR 63.114(a)-(c) and (e)-(g) [DIRS 180319] are met. Descriptions of how information in this report addresses the acceptance criteria associated with the integrated subissue of "Airborne Transport" are provided in Appendix E.

4.3 CODES, STANDARDS, AND REGULATIONS

Other than the citations discussed in Section 4.2, there are no specific formally established codes, standards, or regulations identified as applying to this scientific analysis activity.

INTENTIONALLY LEFT BLANK

5. ASSUMPTIONS

5.1 MAGMA FLOODING OF REPOSITORY FROM AN IGNEOUS INTRUSION

Assumption: When a main, drift, turnout or other extension is hit (intersected) by a dike, magma inundates all repository openings, and therefore inundates the total inventory of waste packages, causing all packages to fail (no longer capable of providing isolation of radioactive waste). Note that this assumption does not apply to conduit intersections. That is covered by Assumption 5.2.

Rationale: Both natural conditions within the drifts (rockfall) and design features may impede magma flow, but the degree of this is unknown. In addition, there are no specific design features that would preclude magma from flowing to all repository drifts. Therefore no credit is taken for either natural or design features

5.2 INTERSECTIONS OF CONDUITS WITH REPOSITORY

Assumption: When a waste emplacement drift is hit by a conduit, then only the number of waste packages that can fit within the profile (footprint) of the conduit are considered to fail. Although magma associated with an eruption may contact other packages along the drift, magma moving with sufficient vertical velocity to entrain waste packages in an eruption is assumed to be located only within the conduit

Figure 5-1 is an illustration of this “cookie cutter” treatment. It shows a conduit profile (red) overlain onto an emplacement drift (green) with waste packages depicted as gray or magenta, depending upon whether they fall within the conduit profile or not. Only packages within the conduit profile (including any fractional waste packages) are considered hit; hence the cookie cutter analogy.

Rationale: Conduits are secondary features, spawned by dikes, which in the cases of concern have already penetrated the repository and filled drifts with magma. Two analyses in *Dike/Drift Interactions* (BSC 2007 [DIRS 177430]), Sections 6.4.8.3.1 and 6.4.8.3.2, evaluate conditions associated with waste packages immersed in magma during conduit development. Section 6.4.8.3.1, Degradation of Waste Packages, determines that magma in the repository would be largely stagnant once all drifts are filled. The section concludes that waste forms not in the conduit profile will remain within the waste packages over the relatively brief eruptive period. Section 6.4.8.3.2, Movement of Waste Packages by Magma, evaluates the possibility that flowing magma could move waste packages initially outside of a conduit towards that conduit. This analysis considers expected magma velocities, pressures, and viscosities, as well as waste package dimensions and mass. The analysis concludes that waste package movement outside of a conduit profile is not expected under these conditions. It also concludes that the conditions are appropriate for waste packages initially within a conduit profile to be lifted up to the surface. Therefore, it is assumed there will be no significant interaction of magma in the conduit with waste packages outside of the conduit boundary.

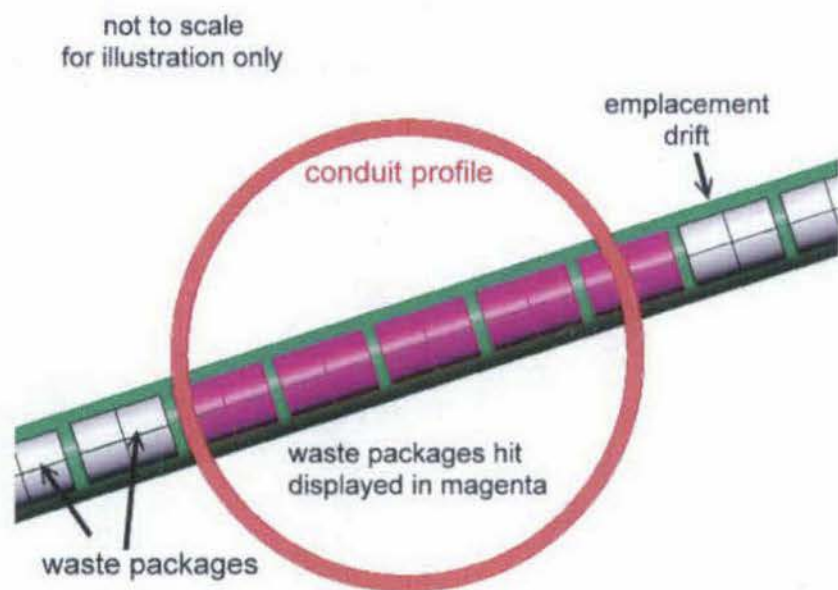

Figure 5-1. Illustration of Eruptive Conduit "Cookie Cutter" Treatment

5.3 MINIMUM SPACING BETWEEN CONDUITS

Assumption: It is assumed that a minimum spacing of 400 m between conduits along a dike is an acceptable representation.

Rationale: A 400-m value acknowledges smaller values for conduit spacing (including for minor vents) listed in Table F-1 of *Characterize Eruptive Processes at Yucca Mountain, Nevada* (SNL 2007 [DIRS 174260]). Note that the minimum spacing of 500 m between conduits (from SNL 2007 [DIRS 174260]) is based upon eruptive vents at eroded analogs that are demonstrably on the same dike. In the present calculations, the minimum spacing is allowed to be 400 m to account for the additional possibility that SW and NE Little Cones, which are spaced approximately 400 m apart, are on the same dike² (SNL 2007 [DIRS 174260], Figure E-8). These volcanoes are not sufficiently eroded to expose the underlying dike system, and therefore the possibility that they lay along a single dike cannot be ruled out.

5.4 CONDUITS ASSIGNED ALONG A SINGLE DIKE

Assumption: Conduits will form along the thickest dike.

Rationale: Several historical observations emphasize that initial linear eruptions (so-called "curtains of fire") along magmatic dikes tend to focus their eruptive activity down to a main location, which becomes the eruptive vent and the source of cone-building material and eruptive

² These two volcanoes are part of the Crater Flat group of Quaternary volcanoes located in southwestern Nevada, adjacent to Yucca Mountain.

ash clouds (SNL 2007 [DIRS 174260], Section 6.3.1). In the case of multiple dikes in a single volcanic event, the thickest dike over a given length will tend to host conduit formation and cone growth. In the Yucca Mountain region, this process is inferred at several locations, including well-exposed sequences such as Basalt Ridge (SNL 2007 [DIRS 174260], Appendix F.2.4) and East Basalt Ridge (SNL 2007 [DIRS 174260], Appendix F.2.5) and the eroded surface exposures of the southeast Crater Flat basalts (SNL 2007 [DIRS 174260], Appendix F.2.6). Each of these eruptive events includes several conduits spaced along the dike length and each conduit occurs along the dominant (thickest) dike in the set.

5.5 ROCK DILATION ANGLE

Assumption: A value of zero degrees is assigned as the minimum dilation angle for all rock types that are evaluated.

Rationale: The minimum value for the dilation angle is assumed to be zero, which represents non-dilatant material. The other extreme case is associated plastic material for which the dilation angle is equal to the friction angle. Because non-dilatant materials are weaker than materials which dilate (and particularly associated materials), the analyses of critical distance between dike and emplacement drift were carried out for a dilation angle equal to zero.

INTENTIONALLY LEFT BLANK

6. DISCUSSION

6.1 ANALYSIS OBJECTIVES

The objectives for these analyses are to develop predictive distributions for the number of waste packages hit (damaged) due to igneous intrusions (dikes) or igneous eruptive events (conduits), and to produce a probability value for conduit occurrence within the repository. These distributions, along with the conduit probability value, will be inputs to the source term determination for the igneous intrusion model case and for the volcanic eruption model case in the TSPA.

6.2 FEATURES, EVENTS, AND PROCESSES INCLUDED IN THE ANALYSIS

The development of a comprehensive list of features, events, and processes (FEPs) potentially relevant to postclosure performance of the Yucca Mountain repository is an iterative process based on site-specific information, design, and regulations. Table 6-1 provides a list of igneous-related FEPs (DTN: MO0706SPAFEPLA.001 [DIRS 181613]) that are included in the TSPA through the use of the results of the analysis described in this document. Detailed discussion of inclusion or exclusion of the disruptive events FEPs is presented in *LA FEP List and Screening (SNL 2007 [DIRS 181613])*.

One or more dikes in the subsurface can be accompanied by formation of scoria cones, spatter cones, ash and lapilli fall, and/or lava flows on the surface (BSC 2007 [DIRS 174260], Section 5). The TSPA addresses the effects of intrusive (dikes) and extrusive (eruptive conduits) igneous activity simultaneously, but these are computationally separated through consideration of the igneous intrusion model case and the eruption model case. In the igneous intrusion model case, waste packages are damaged by magma that intrudes into the repository, but eruptive conduits do not form. Radionuclides are released from the cooled magma to the unsaturated zone by groundwater flow and transport processes once percolation is re-established. This model case is described in Section 6.3.2.2.

In the eruption model case, magma rising to the surface in a conduit carries radioactive waste with it. One or more eruptive conduits transport magma with entrained waste to the surface. Some fraction of the contaminated magma is erupted into the atmosphere (SNL 2007 [DIRS 177431] Section 6.3.2.22), dispersed downwind, and deposited onto and transported along the ground surface (SNL 2007 [DIRS 179347]). This allows for pathways reaching the reasonably maximally exposed individual via either atmospheric or fluvial sediment transport. The eruption model case is discussed in Section 6.3.2.2 of this report.

The eruptive center probability (ECP) is a measure of the relative frequency of conduit formation within the repository footprint, given that at least one dike has intersected the repository.³ The ECP model case is described in Sections 6.3.4, and 7.1.

³ The terms "eruptive center," "eruptive event" "eruptive conduit," and "conduit" are used interchangeably throughout this document.

The parameters and distributions developed as output in this report are used directly in TSPA. The FEPs listed in Table 6-1 are part of the conceptual basis for the model cases described in this report.

Table 6-1. Included FEPs for this Report

TSPA FEP Number	TSPA FEP Name	Disposition Description Location
1.2.04.03.0A	Igneous Intrusion into Repository	Sections 4, 6.3.2, and 7
1.2.04.04.0A	Igneous Intrusion Interacts with EBS Components	Sections 4, 6.3.2, and 7
1.2.04.06.0A	Eruptive Conduit to Surface Intersects Repository	Sections 4, 6.3.2, and 7

Source for columns 1 and 2: DTN: MO0706SPAPEPLA.001 [DIRS 181613].

6.3 ANALYSIS

In a departure from the previous versions of this report (such as BSC 2005 [DIRS 174066]), and as detailed in Section 5.1, this analysis explores conditions that include those where no credit is taken for natural or man-made barriers, as reflected by the numbers of waste packages hit. This is necessary because the current repository design does not include engineered structures that could limit magma flow within the repository (SNL 2007 [DIRS 179466], Table 4-3). Under this set of conditions, for the igneous intrusive case only, if any drift is breached by a dike, then the entire repository inventory of waste packages (11,629 packages; see DTN: MO0702PASTREAM.001 [DIRS 179925]) is tallied as hit. If the repository perimeter is breached by any dike, but no drift is breached (possible under certain circumstances), then the tally for waste packages hit is still ultimately treated as the entire repository inventory. This is because repository access and exhaust mains comprise the perimeter of the repository. Those mains provide access for magma from dikes to reach all emplacement drifts. This leads to a cumulative distribution function (CDF) for the igneous intrusive case that is essentially a vertical line segment, because 11,629 is the result for every valid case.

The basic approach of this analysis is summarized in the following steps:

1. Capture the repository geometries of interest (design inputs). This step is described in Section 6.3.1.
2. Capture the stochastic igneous parameter sets of interest (igneous inputs). This step is described in Section 6.3.2.
3. Use DIRECT to overlay these features against each other. In so doing, DIRECT calculates the numbers of waste packages hit by igneous events (both intrusive and eruptive), within a stochastic framework, and feeds these numbers to output files. This step is described in Section 6.3.3.
4. Because of the nature of the stochastic feeds, many of the resulting DIRECT output cases (also called sets or realizations) are screened out. This step is described in Section 6.3.4.

5. From the remaining valid cases, the two final CDFs (one for the intrusive and one for the eruptive case) are determined. The value for ECP (a ratio) is calculated by dividing the number of cases in which conduits intersect the repository by the number of cases in which dikes intersect the repository. These products are developed and documented in data packages.

Tallies of waste packages for the intrusive case are also adjusted due to the operating assumption (see Section 5.1) that, if any drift is intersected by a dike, then the entire inventory of waste packages is considered to be hit (for the intrusive case only).

This step is discussed further in Sections 6.3.3 and 7.

Figure 4-1 maps the flow of data from qualified inputs to the outputs of this analysis. The data flow generally corresponds to these five steps. The corresponding sections follow.

6.3.1 Repository Geometry

The repository geometric features of interest include the 108 emplacement drifts and their associated extensions and turnouts at either end. Items 1 through 5 in the first part of Table 4-1, Repository Design Inputs, cover these data feeds.

Figure 6-1 is an overlay of the repository representation of DIRECT against the current repository layout figure from item 1 of Table 4-1. The DIRECT representation consists of the bolder lines, representing emplacement drifts, turnouts and extensions, as well as the green outline. The background grid spacing is 500 m.

As described in step 3, DIRECT provides granular totals of the number of waste packages in each drift that is intersected by a dike. The code as used, therefore, treats each drift as isolated from each other drift. The single exception to this drift isolation treatment involved combining the top eighteen drifts (located in panels 4 and 3w) into nine pairs of two drifts, with a 30-m gap between each pair (Figure 6-1). This reduced the total number of drifts from 108 to 99. These particular drifts were combined in this way because the nine pairs are collinear and the gap between each drift pair is only 30 m.

Combination of the top nine drift rows adds 270 meters to raise the total emplacement drift length from 65,273 m to 65,543 m (see item 7 in Table 4-1). Additional details of development of the DIRECT repository geometry are provided in Appendix A.

6.3.2 Igneous Intrusive and Eruptive Analyses

There are eight direct igneous parameters of interest (items 9 through 16 of Table 4-1). For this stochastic analysis, a sufficient number of plausible cases for each igneous parameter must be synthesized to produce a CDF (for the number of waste packages hit) that is suitable for delivery to TSPA. Synthesis of these parameters is accomplished along two major branches, which lead to two separate igneous feeds to DIRECT. Both branches develop four "replicates" of feeds of 1,000 samples each.

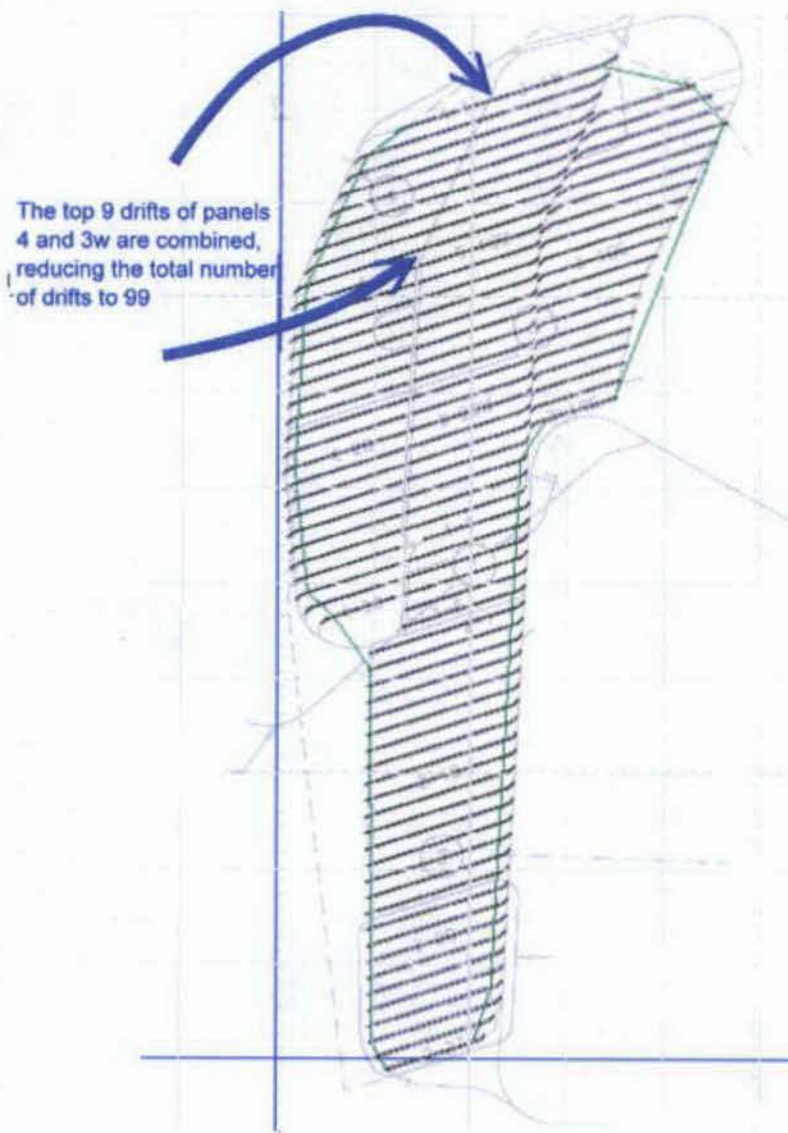

Source: SNL 2007 [DIRS 179466], Table 4-1; also output DTN: SN0701PAWPHIT1.001.

NOTE: The gray grid is 500 m square.

Figure 6-1. Overlay of DIRECT V. 4.0 Representation of Repository onto Repository Design

One igneous branch addresses the question of where the centroid of a swarm of dikes could be located. Spreadsheet calculations, which are fed the first igneous parameter (item 9 in Table 4-1), address this branch, and result in an independent file of slightly over 1,000 samples that is input to DIRECT for each replicate. The spreadsheet and its calculations are detailed in Appendix A.

The other igneous branch concerns the geometric and quantitative characteristics of the dike swarm, as well as any associated eruptive conduits. The software code LHS V. 2.51 is used in conjunction with the remaining seven igneous parameter inputs of Table 4-1 (items 10 to 16) to

synthesize an independent file of slightly over 1,000 samples that is input to DIRECT for each of the four replicates. Upon execution, DIRECT evaluates exactly 1,000 samples per replicate.

6.3.2.1 First Stochastic Igneous Branch, Dike Swarm Seed Locations and Frequencies

The first input parameter (for the first stochastic igneous branch, item 9 of Table 4-1) is based upon dike swarm seed location frequencies. This parameter was originally developed in *Characterize Framework for Igneous Activity at Yucca Mountain, Nevada* (BSC 2004 [DIRS 169989], Section 6.5.3, and Figure 6-11a). That analysis summarizes and builds upon *Probabilistic Volcanic Hazards Assessment for Yucca Mountain, Nevada* (CRWMS M&O 1996 [DIRS 100116]), in which the interpretations of an expert panel were used to compute a probability distribution of the annual frequency of intersection of basaltic dike swarms with the repository footprint. Among other topics, the analysis develops origin location frequencies for the igneous event.

Figure 6-2 is adapted from that prior study (BSC 2004 [DIRS 169989], Figure 6-11a). The repository is represented by the small black rectangle in the center of the figure. The spatial distribution of expected volcanic event frequency is depicted over a large area encompassing the repository. As shown, the greatest frequencies of volcanism are expected to occur several kilometers to the southwest of the repository. The frequency decreases moderately to the northeast from there.

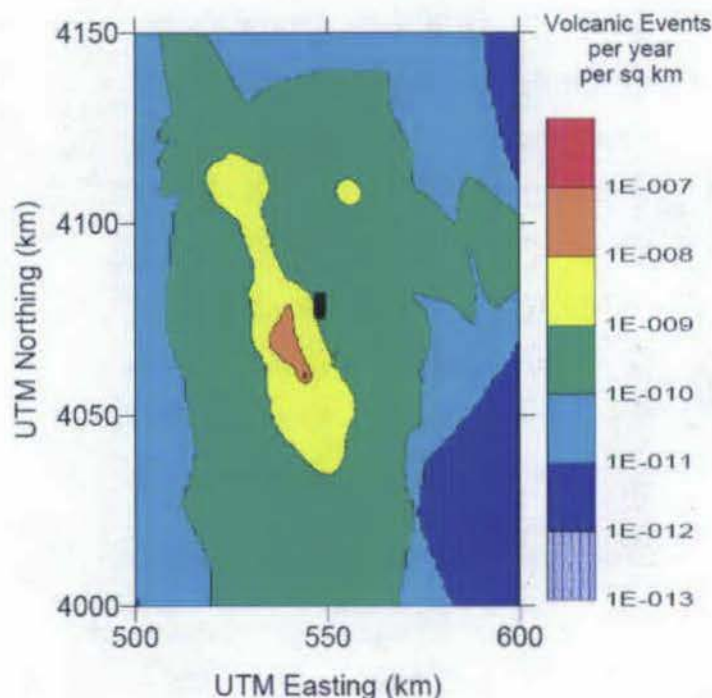

Source: BSC 2004 [DIRS 169989], Figure 6-11a.

NOTE: Black rectangle in center of figure represents repository; UTM = universal transverse Mercator.

Figure 6-2. Spatial Distribution of Expected Volcanic Event Frequency

Figure 6-3 shows a subset of the data used to implement the spatial grid of expected volcanic event frequency in Figure 6-2. Each cell of that distribution is a one-kilometer square, represented by the blue diamonds (the diamonds represent the center of each square only). The repository outline is shown in green. Because of limitations on dike lengths, which cannot exceed 8 km, a subset of these data was used for the actual feeds to DIRECT; the magenta squares within the blue diamonds indicate this subset. According to this, a dike swarm, centered anywhere along the margins defined by the outermost magenta squares, could conceivably reach the repository, up to 4 km away.

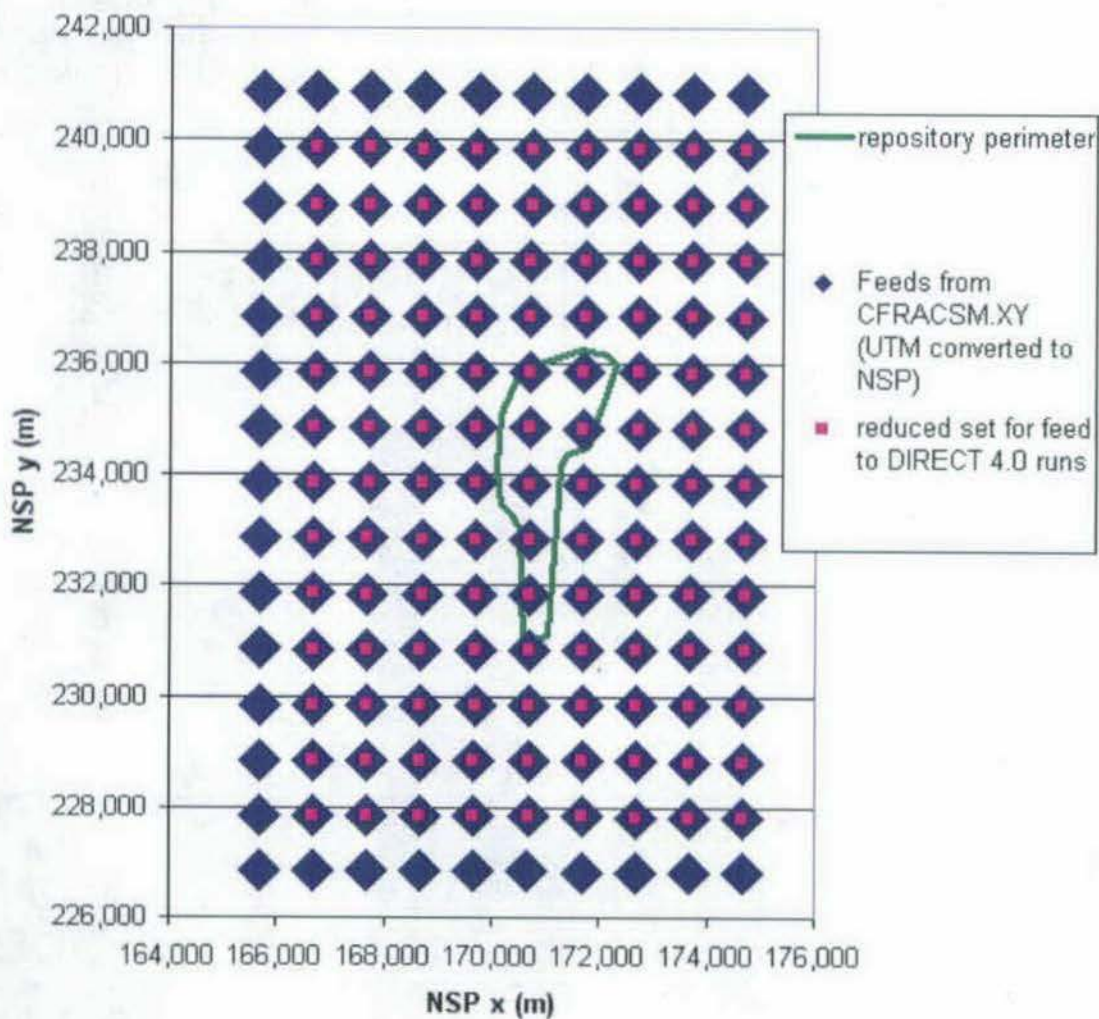

Output DTN: SN0701PAWPHIT1.001 file: *DikeSeeds_07.xls*, worksheet "NSP_sourceCoords" (see Appendix A of this report).

NOTE: NSP = Nevada state plane coordinate system; UTM = universal transverse Mercator. Vertical and horizontal scales vary slightly.

Figure 6-3. General Coverage in Which Dike Swarms Can Be Centered and Conceivably Intersect the Repository

Each of those frequency data points defines a square kilometer within which any location has the same probability of occurrence. As detailed in Appendix A.2 and Table A-1, these data points were extracted, normalized, and used in a spreadsheet to synthesize roughly 1,050 dike-swarm centroid realizations per replicate. A replicate of 1,000 samples is ultimately desired for DIRECT runs, but an artifact of the spreadsheet approach produces slightly more than that number.

Figure 6-4 shows the resulting centroid locations for all samples from all replicates as blue crosses. In this figure, the grid is composed of squares 1,000 m per side, and the coordinates have been shifted to reflect the operational domain customized to this analysis. The moderate decrease in point density from southwest to northeast is discernable in this figure and accurately reflects the spatial distribution of expected event frequency from which it is adapted (Figure 6-2).

Those cases that actually lead to dikes which intersect the repository footprint are shown as crosses embedded in magenta squares in Figure 6-4. These cases are primarily a result of the variations in dike swarm lengths, widths, and orientations, among other things. Those dike features comprise the second igneous stochastic branch and are described below.

Also, some centroid locations fall within the repository footprint, yet do not register as “hits” (intersections). This is usually due to screening logic. For example, a dike set initially generated from the LHS code may have a length that falls short of the truncation limit and therefore must eventually be ruled out via this screening logic, even if the dike centroid location is inside the repository footprint. More details on the screening logic applications are provided in Table 6-3.

The set of magenta “hit” cases forms a roughly elliptical shape that can be compared approximately to Figure 6-11b of *Characterize Framework for Igneous Activity at Yucca Mountain, Nevada* (BSC 2004 [DIRS 169989]). The differences in length and orientation are a result of the newer distributions for the dike geometry parameters (SNL 2007 [DIRS 174260], Table 7-1).

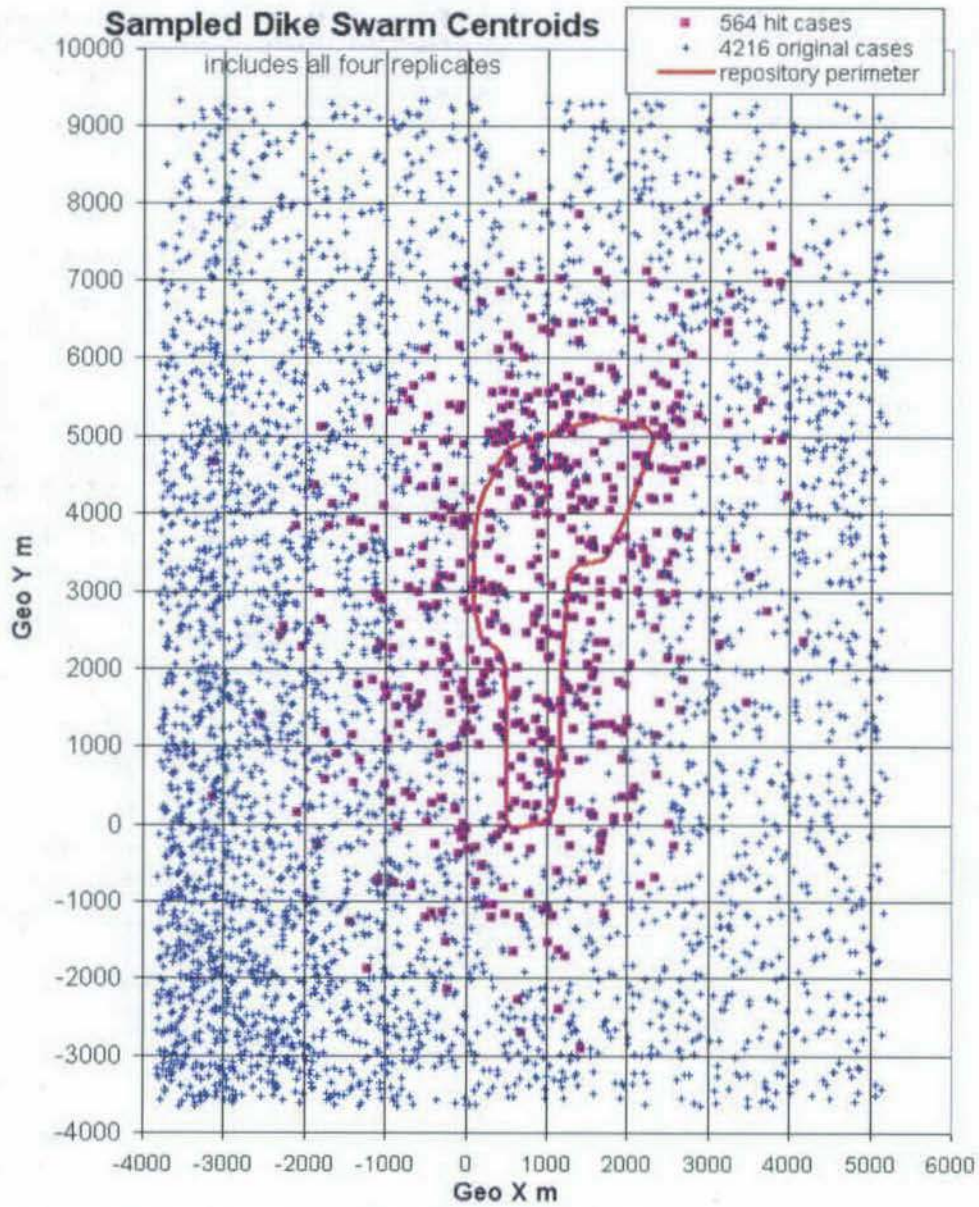

Output DTN: SN0701PAWPHIT1.001, files: *DikeSeeds_07.xls*, *ResultsPrelimCase00_amr.xls*, *ResultsPrelimCase01_amr.xls*, *ResultsPrelimCase02_amr.xls*, *ResultsPrelimCase03_amr.xls*.

Figure 6-4. Sampled Dike Swarm Centroids

6.3.2.2 Second Stochastic Igneous Branch, Geometric and Quantitative Characteristics of the Dike Swarm and Associated Eruptive Conduits

The second stochastic branch encompasses all remaining igneous parameters that are most conducive to distribution synthesis through use of the LHS code (Table 4-1, items 10 through 16). With the exception of minimum eruptive conduit spacing, all of these parameters come from the single DTN: LA0612DK831811.001 [DIRS 179987]. As described in Section 4.3, LHS approximates the Monte Carlo method without missing representative distribution tail values. This offers opportunities to reduce the required number of samples to sufficiently address uncertainty. However, as described later in the discussion of screening logic (Section 6.3.4 and Table 6-3), LHS does not have the ability to process user-defined truncations of a normal distribution, and therefore, truncations are performed after LHS results are produced.

The first element of this branch (Table 4-1, item 10), is a tabular distribution of dike azimuth angles. Through use of the LHS code, this analysis allows for continuous variation from one azimuth bin to the next. Therefore, virtually any azimuth angle can be sampled, as long as the general distribution shape is still captured. The second element of this branch (Table 4-1, item 11) is the distribution of dike lengths and is a specification of a normal distribution with a mean value of 2 km and a 95th percentile of 6 km. For this analysis, two limits to the distribution are specified: 0.4 km at lower end and 8 km at upper end. The upper limit is approximated in this analysis, because LHS by default applies a truncation at the 99th percentile, which equals 7,657 m. This default upper limit used by LHS is described in Appendix A. The remaining truncation for the lower limit is handled by a flag from the DIRECT code, during processing, followed by culling of those cases in postprocessing steps, prior to final CDF generation. This process is discussed in more detail in Section 6.3.4, Screening Logic, and in Table 6-3.

The third element of this branch (Table 4-1, item 12) is the distribution of dike thickness. This distribution is defined as a normal distribution with a mean of 8 m and a 95th percentile of 12 m. Although a lower limit of 1 m is specified in the table, the LHS code actually sets the lower limit to 2.343 m, because that represents the default 1st percentile. This default lower percentile limit used by LHS is discussed in Appendix A.3. In the few cases where the thicker minimum value might be expressed, its use would, if anything, increase the chance of an intersection with a drift.

Within the DIRECT code, these basic dike widths are increased by an effective extension, called a "halo," to the dike width (added to both sides of dike) due to anticipated fracturing of lithophysal rock through which a dike penetrates. A detailed rationale and study of this phenomenon is included in Appendix G. Figure 6-5 depicts a sample dike as a vertical red slab sandwiched between two gray slabs. Each gray slab represents the sampled halo width extension. One of the gray slabs is shown intersecting a waste emplacement drift, depicted as the green cylinder. In this example, the drift would be treated as "hit" by DIRECT, even though the dike does not directly intersect the drift.

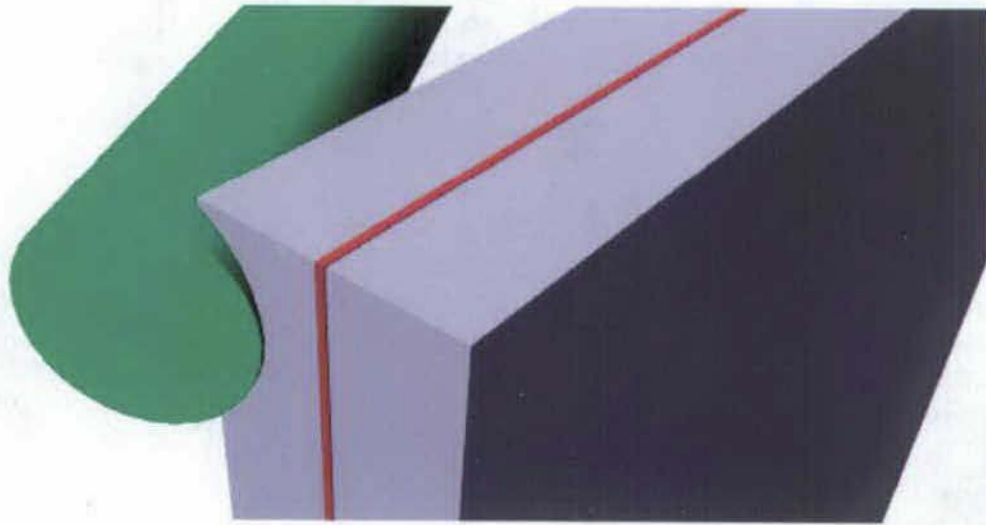

For Illustration Only. Not to Scale.

Figure 6-5. Example of a Dike – Drift 'Hit' Case Caused by Halo Intersection with Emplacement Drift

The remaining two sampled dike parameters, the number of dikes in a swarm and the spacing between dikes (Table 4-1, items 13 and 14), are tabular and random uniform distributions, respectively. No truncations or other modifications are required to these parameters, and they do not directly affect any subsequent screening logic.

Conduit parameters comprise the last component of this igneous set. The number of volcanic conduits is a discrete probability set (Table 4-1, item 15), ranging from one to three conduits. The distribution for conduit diameter is defined as normal with a mean of 15 m and a 95th percentile of 21 m (Table 4-1, item 16). Although a lower limit of 1 m is specified in the table, the LHS code actually sets the lower limit to 6.515 m, because that represents the default 1st percentile. This default lower percentile limit used by LHS is discussed in Appendix A. In the few cases where the lower limit might be expressed, the larger minimum value would, if anything, increase the chance of an intersection with a drift. In addition, and in line with the input description, DIRECT is programmed to reset any conduit diameter to the total parent dike width, if the dike width is larger than the conduit diameter. However, if the conduit diameter is larger than the total dike width, then no changes are made.

Conduits that occur within or near the repository are simulated by conditional linkage to the igneous intrusion calculations. According to *Characterize Eruptive Processes at Yucca Mountain, Nevada* (SNL 2007 [DIRS 174260], Section 6.3), and as detailed in Assumption 5.4, Section 5 of this report, for every dike swarm, a single dike (measured within a horizontal plane that cuts through the swarm) provides a range of locations for spawning a sampled number of conduits (each with a variable diameter). Conduits are constrained to occur only along the midline of the thickest dike, according to a simple random uniform process. Diameters of conduits are allowed to vary but can be no smaller than the width of the parent dike (including any dike width extensions) along which they form. As stated in Assumption 5.2, Section 5 of this report, conduits are represented according to this approach and are treated as "cookie cutters," by only calculating the likely number of intersected waste packages.

The DIRECT code attempts to ensure that the conduit parameter, minimum spacing between conduits along a dike (Assumption 5.3, Section 5), is honored. However, cases are possible in which the dike is too short to accommodate this condition. In those cases, DIRECT applies screening logic, and a postprocessing step ensures that the violating cases are removed from the results before any CDFs are produced. Further details on this screening are provided in Section 6.4.

6.3.3 Use of DIRECT Software to Produce Preliminary Results

As stated at the beginning of Section 6.3, ultimate tallies of the numbers of waste packages hit by igneous intrusion are adjusted to reflect the total expected waste package inventory. However, the DIRECT code output is more granular. It provides only the number of waste packages in intersected drifts. The correction to total waste package inventory for all non-zero cases is performed in a postprocessing step, as detailed in Appendix B.

No corrections are needed for the eruptive case, due to the assumption in Section 5.2.

An example of an igneous parameter sample set is provided here, along with the quantitative and graphic results from the DIRECT code. The example chosen, Set 679 of Replicate 03, is exemplary of a case in which both dikes and a conduit intersect drifts. Table 6-2 summarizes the igneous parameters for this sample.

Figures 6-6 through 6-9 show the same DIRECT result at successively increasing scales. The first image depicts the result at the smallest scale, which is comparable to the scale used previously in Figure 6-4. The final image is a close-up of the single conduit for this case. Figures 6-8 and 6-9 are for illustration purposes only.

Table 6-2. Summary of Selected Igneous and Related Parameter Inputs for Set 679 of Replicate 03

Parameter	Input Value
Number of dikes	3
Length of each dike	2,464 m
Azimuth angle of each dike	13.75 degrees
Maximum: Width of dike + proximity halo combination (2X the halo value)	$8.3 + 2*(6.5) = 21.3$ m
Number of conduits	1
Diameter of conduit	16.5 ^a
X coordinate of dike swarm centroid	894 m ^b
Y coordinate of dike swarm centroid	4,139 m ^b
Spacing between thickest dike and next dike to left	890.7 m
Spacing between two left-most dikes	145.5 m

Output DTN: SN0701PAWPHIT1.001.

NOTE: ^a This diameter is later reset by DIRECT [DIRS 179574] to equal width of thickest dike.

^b Values in "Geo" coordinate system.

Complementing the previous discussion, the following factors apply to these and all other DIRECT graphic results:

1. The long vertical and horizontal blue lines represent the axes for this operational domain, which is termed the "Geo" coordinate system.
2. Each grid square (gray) is 500 m to a side.
3. The green cross (+) represents the sampled center of the dike swarm.
4. The two green Xs (not to be confused with the green cross) represent the dike length extents for a hypothetical dike that is centered at the centroid. This is simply a feature of convenience and is not involved in any further calculations.
5. The red lines represent the sampled dikes.
6. The blue circles represent the sampled conduits.
7. The green line is a feature of convenience that helps define the repository perimeter.
8. The black lines represent the repository emplacement drifts, turnouts, and extensions. Each of these is variable in length, but each is always 5.5 m wide.
9. When a turnout, extension, or emplacement drift is intersected by a dike, then the emplacement drift color changes to magenta. Also DIRECT produces a tally of waste packages hit by dikes based on an implicit assumption that all packages in that drift are damaged. Although more than one dike may intersect a drift, DIRECT ensures that waste packages hit are not tallied multiple times.
10. This report operates on the assumption that, when any drift, turnout or extension is hit by a dike, then all waste packages in the entire repository are hit. That condition is asserted in a postprocessing step (after DIRECT results are produced), prior to final CDF generation.
11. When a conduit intersects an emplacement drift, DIRECT determines the length of intersected drift, divides that length by the input average waste package length, and rounds up to determine the tally of number of waste packages hit.

A reviewer can use these factors, along with previous discussion, to confirm the LHS example table inputs are correct.

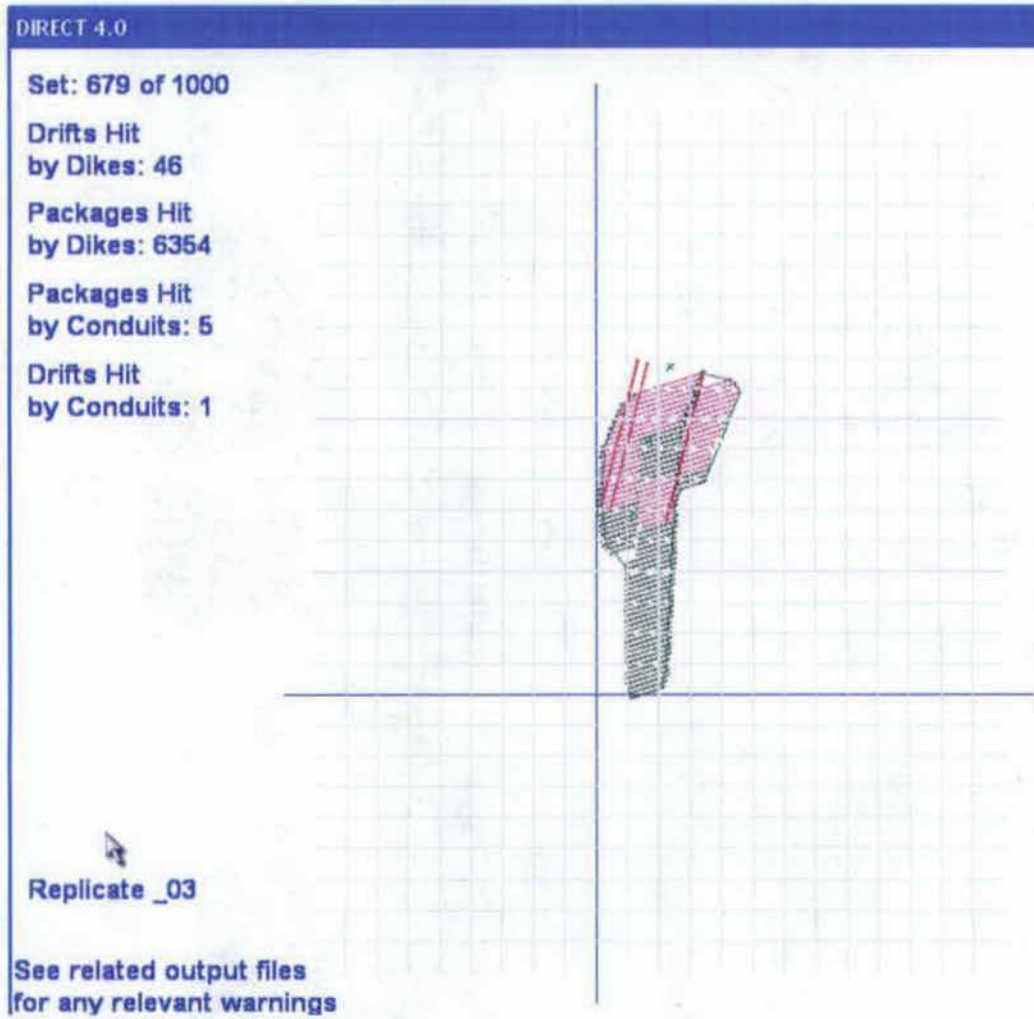

Output DTN: SN0701PAWPHIT1.001.

Figure 6-6. Sample DIRECT V. 4.0 Output, Replicate 03, Set 679, Remote View

DIRECT 4.0

Set: 679 of 1000

**Drifts Hit
by Dikes: 46**

**Packages Hit
by Dikes: 6354**

**Packages Hit
by Conduits: 5**

**Drifts Hit
by Conduits: 1**

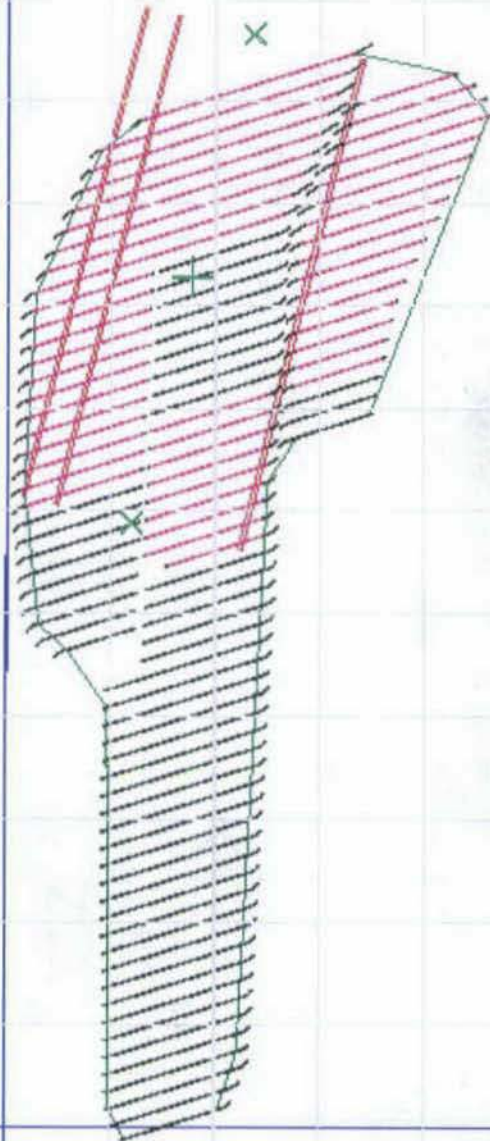

Replicate _03

**See related output files
for any relevant warnings**

Output DTN: SN0701PAWPHIT1.001.

Figure 6-7 Sample DIRECT V. 4.0 Output, Replicate 03, Set 679, Standard View

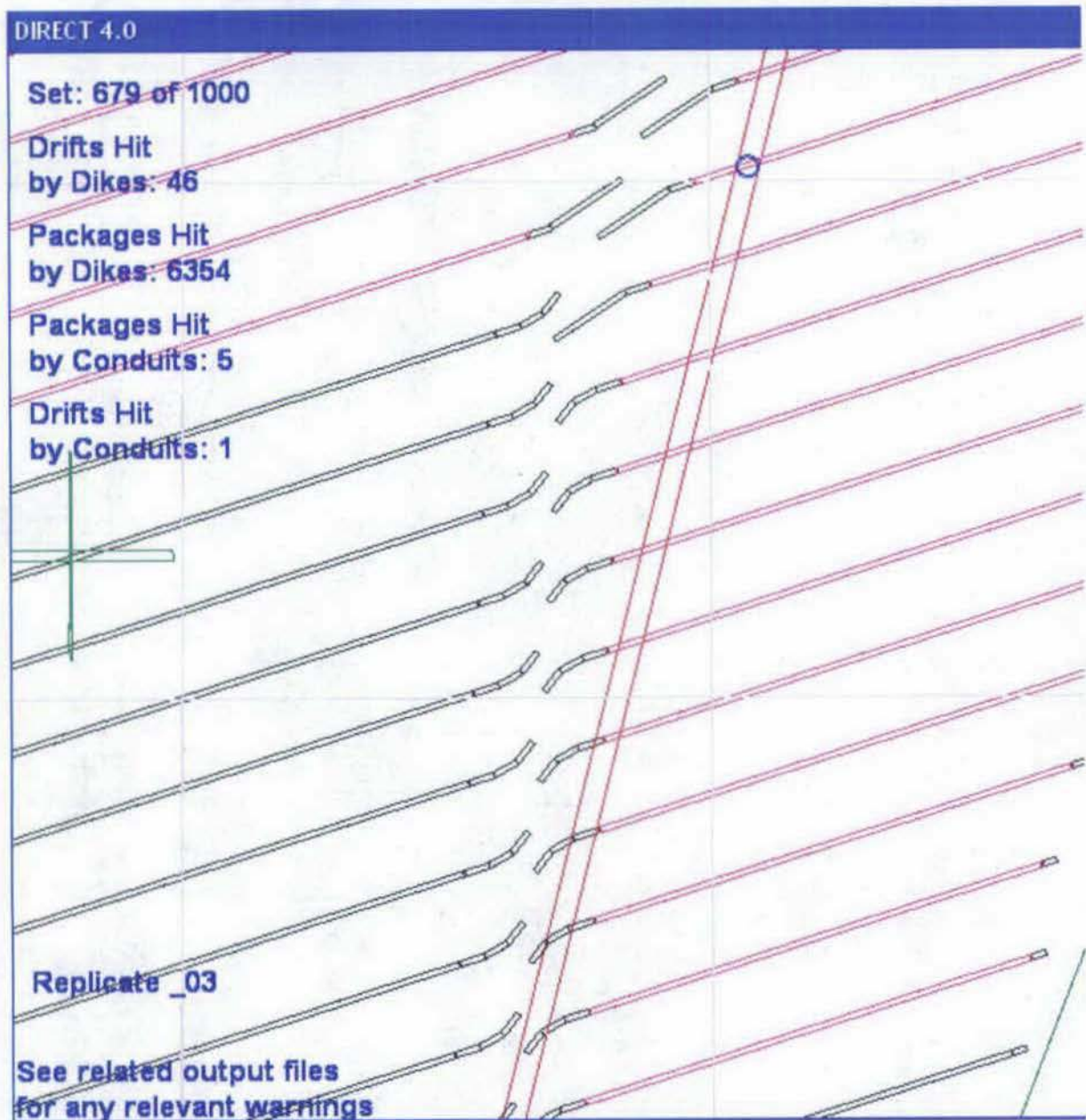

This graphic is supplied for illustration purposes only.

Figure 6-8. Sample DIRECT V. 4.0 Output, Replicate 03, Set 679, Detail

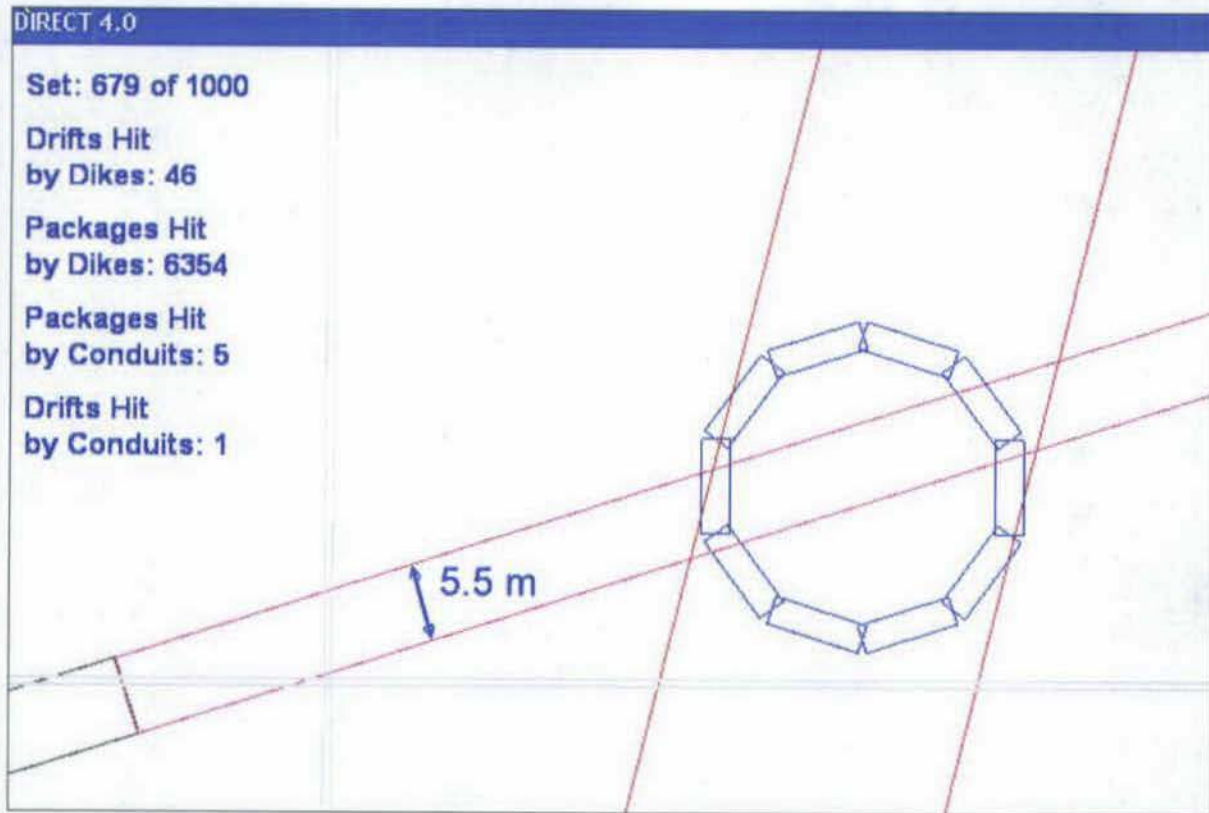

This graphic is supplied for illustration purposes only.

Figure 6-9. Sample DIRECT V. 4.0 Output, Replicate 03, Set 679, Detail of Conduit—Drift Intersection

DIRECT also produces an extensive array of output files. Some are for diagnostic purposes, others relate to screening logic, and finally, a base set of output files is supplied that provides preliminary numbers of waste packages hit by eruptive and by intrusive events. Outputs are described in greater detail in Appendix B, as well as where appropriate in the following section on screening logic.

6.3.4 Screening Logic and Subsequent Final Development Steps

As described earlier, and suggested in Figure 6-4, of over 4,000 initial sample cases, approximately one eighth of the cases pass the screening criteria. All primary screening criteria are summarized in Table 6-3 below.

Table 6-3. Screening Criteria Information for Output from DIRECT V. 4.0 Runs

Screening Issue	Application
Screening issues for elimination of invalid cases	
Dikes must intersect the repository footprint. This is a necessary condition for TSPA feeds.	All DIRECT results are visually examined, and cases that do not meet this condition are eliminated from further analysis. This is captured by the spreadsheet series (one for each replicate), <i>ResultsPrelimCase0#d.xls</i> , detailed in Appendix B.
Dike length and width distributions require truncation of normal tails	DIRECT outputs a file, <i>DikeFail.txt</i> , which flags all cases where dikes are too thin, too short, or too long. Those files, one for each replicate, are then processed in the spreadsheet series <i>ResultsPrelimCase0#d.xls</i> , detailed in Appendix B. For archiving purposes, the file name is changed to <i>DikeFail_##.txt</i> , where ## stands for replicate number. See Appendix B.
Dikes cannot have a zero or near-zero azimuth; otherwise the DIRECT intersection algorithms fail.	DIRECT outputs a file, <i>DikeAzFail.txt</i> , that flags all cases where the sampled azimuth creates this condition. Those files, one for each replicate, are then processed in the spreadsheet series <i>ResultsPrelimCase0#d.xls</i> , detailed in Appendix B. For archiving purposes, the file name is changed to <i>DikeAzFail_##.txt</i> , where ## stands for replicate number. See Appendix B. Only one case per replicate (at most) gets flagged by this screening logic.
Inter-conduit spacing must honor minimum distance criteria.	DIRECT outputs a file, <i>ConSpaceFail.txt</i> , which flags all cases where conduits are too close together. Those files, one for each replicate, are then processed in the spreadsheet series, <i>ResultsPrelimCase0#d.xls</i> , detailed in Appendix B. For archiving purposes, the file name is changed to <i>ConSpaceFail_##.txt</i> , where ## stands for replicate number. See Appendix B.
Screening to facilitate above and to prevent improper eliminations of samples	
Visual capture of valid conduit cases (whether or not any waste packages are hit)	DIRECT outputs a file, <i>ConCapture.txt</i> , that flags all cases where conduits at least fall within a rectangle defined by the maximum extents of the repository perimeter. Those files, one for each replicate, are then processed in the spreadsheet series, <i>ResultsPrelimCase0#d.xls</i> , detailed in Appendix B. The repository perimeter, shown as the green outline in Figure 6-1, has an irregular boundary, and therefore <i>ConCapture.txt</i> will flag some cases that do not actually have conduits within the repository footprint. From that point, the user visually determines in which of these subset cases at least one conduit falls within the repository footprint. All other conduit cases are then eliminated. For archiving purposes, the file name is changed to <i>ConCapture_##.txt</i> , where ## stands for replicate number. See Appendix B.

Output DTN: SN0701PAWPHIT1.001.

These screening steps are performed in several worksheets within the spreadsheets *ResultsPrelimCase0#amr.xls*, where the “#” character signifies the replicate identification number (0, 1, 2, or 3). In other words, each replicate population is processed in an identical manner, but within its own spreadsheet. Appendix B provides additional details and further points to the heavily annotated spreadsheets.

The final results are developed in two spreadsheets that draw from the combined four preliminary spreadsheets just described.

The first primary TSPA output, **Num_WPs_Hit_Intrusive_a**, represents the number of waste packages hit by igneous intrusions. This is a tabular CDF and is found in the worksheet

“amrNwphIntrusive” of the spreadsheet *Num_WPs_Hit_Intrusive_amr.xls*. After screening of the initial population of 4,000 cases, the population of valid results used to produce this CDF is 564.

The second primary TSPA output, **Num_WPs_Hit_Eruptive_a**, represents the number of waste packages hit by eruptive conduits. This is a tabular CDF and is found in the worksheet “amrNwphEruptive_a” of the spreadsheet *ConduitsECP_and_ConduitsWPH_amr.xls*. After screening of the initial population of 4,000 cases, the population of valid results used to produce this CDF is 155.

The final primary output is a single number representing the TSPA parameter **Eruptive_Center_Probability_a**, contained in worksheet “amrECPa” of the spreadsheet *ConduitsECP_and_ConduitsWPH_amr.xls*. This parameter is developed by taking the ratio (and using the Excel ‘ceiling’ function to round up) of the number of valid results from **Num_WPs_Hit_Eruptive_a** over the number of valid results from **Num_WPs_Hit_Intrusive_a**. Therefore the value of this parameter is 0.28. This ratio represents the probability of an eruptive center intersecting the repository, given that an igneous intrusion has intersected the repository. It is identical to the ECP parameter described in Section 6.1.

6.4 UNCERTAINTY

The analysis addresses uncertainty primarily through stochastic treatments of outputs in the forms of CDFs. The outputs for the intrusive and eruptive cases of number of waste packages hit both consist of a discrete rank-ordered set of stochastically generated values (usually representing an x axis), mapped against their relative fraction of non-exceedance (representing the y axis, with maximum value equal to 1.), which effectively constitutes a CDF. This distribution is justified through a description of the input distributions and the calculation approaches that have been implemented.

Any uncertainties in timing/occurrences of igneous events are covered by TSPA abstractions. The remaining major identified uncertainties can be addressed within three areas: design uncertainty, igneous uncertainty, and numerical uncertainty. This analysis acquires those uncertainty distributions and incorporates them into the document. This analysis also includes a “buffer zone” to address uncertainty in proximal effects of dikes on drifts through rock-failure processes.

6.4.1 Repository Design Uncertainties

Repository design uncertainty is addressed primarily through supporting reports. The repository drift endpoint coordinates have been given an uncertainty value of ± 10 m (SNL 2007 [179466], Table 4-1).

6.4.2 Epistemic Igneous Uncertainties

Igneous uncertainty is addressed primarily through supporting reports. In addition, this analysis produces a value for ECP (see Section 6.3.4) that, due to differences in uncertainty approaches, inputs, and analyses, departs from previous studies. The ECP remains a measure of the

probability of an eruptive center (intersecting the repository), given that an igneous event has intersected the repository.

The new value of ECP is 0.28, whereas the original value was 0.78 (BSC 2004 [DIRS 169989], Table 7-1). The differences in approach to obtaining these values are summarized below along with a subsequent alternate ECP construction, which constitutes an exploration of epistemic, or model, uncertainty.

That original value was developed based on probabilistic volcanic hazard analyses (CRWMS M&O 1996 [DIRS 100116]), which considered a single dike penetrating the repository in all cases. Integrated into the estimate originated by the probabilistic volcanic hazard analyses were considerations of the possibility that the repository presence could influence the occurrence of dikes. The effort included probabilistic weighting applied to several alternative possibilities for conduit spacing along a dike. For example, two alternatives considered that the parent dike is divided up into equally spaced segments, one for each conduit (BSC 2004 [DIRS 169989], Section 6.5.1.3, p. 6-59). In addition, correlation between dike length and number of eruptive conduits—and lack of correlation of same—were considered and included in the probability estimates. Following the development of weighted probabilities for each value of number of conduits under all alternatives, an array of ECP values could be directly calculated by subtracting the composite probability (under three percentile cases, including the mean) for zero conduits in the repository from the number 1. That analysis is captured in Section 6.5.3 of *Characterize Framework for Igneous Activity* (BSC 2004 [DIRS 169989]), where it is partially summarized in Table 6-11. The middle section of that table, under the subheading “Conditional Distributions for Mean Frequency of Intersection” represents a mean case (one column per case) for each of the alternatives by listing the probabilities for zero conduits, one conduit, and so on, at one entry per row. The combined probabilities for each alternative always sum to 1. The seventh column, “Weighted Average for Random Location,” as its title indicates, provides the weighted averages for the alternatives represented by columns 2 through 6. The remaining columns of the table incorporate additional significant departures, in which the repository is considered to strongly influence the formation of a conduit.

The top entry of probability for zero conduits, for any alternative, can be used to calculate the probability of at least one conduit intersecting the repository, by simply subtracting that value from the number one, as described earlier.

The current analysis does not factor in a possibility that the repository can influence conduit formation. This is based on analyses described in Section 6.3.3.5.6 (SNL 2007 [DIRS 177430]).⁴ Therefore the most suitable ECP value from Table 6-11 of *Characterize Framework for Igneous Activity* (BSC 2004 [DIRS 169989]) for comparison to the current ECP value is the mean case for the column titled “Weighted Average for Random Location.” The value for zero conduits is 0.435, which when subtracted from the number 1, yields an ECP approximately equal to 0.56.⁵

⁴ The analyses suggest that drifts do not promote conduit formation.

⁵ The similarity of 0.435 to a subsequent ECP value described at the end of this section is purely coincidental.

The ECP value of 0.56 is still 100% greater than the current value of 0.28, and it is worthwhile to consider other variances in approach in more detail. The current analysis has a number of additional departures of input parameter treatments from the earlier work:

- The current repository design is incorporated
- The distributions from analogous volcanoes from the Yucca Mountain region for numbers, lengths, azimuth angles, and widths of dikes are incorporated, as documented in *Characterize Eruptive Processes at Yucca Mountain, Nevada* (SNL 2007 [DIRS 174260])
- The ECP is now directly calculated by dividing the number of valid conduit sample cases by the number of valid dike sample cases. Those cases are themselves calculated via the DIRECT code, which utilizes geometric intersection algorithms not applied in earlier ECP calculations.

Some data output can be extracted from the existing results to examine an alternate ECP construction that is somewhat more aligned with the original approach used in *Characterize Framework for Igneous Activity* (BSC 2004 [DIRS 169989]).

In the current calculation of ECP, as described in Section 7.2, the parameter is developed as a ratio between the number of valid conduit cases and the number of valid dike cases. The number of valid dike cases, in the denominator, is defined as the total of all valid cases in a sample in which at least one dike (whether or not it is the thickest) touches the repository footprint.

For this alternate ECP construction, the number of valid dike cases is defined as the total of all valid cases in a sample in which the thickest dike (which is always the dike where conduits are assigned for this analysis) is found to touch the repository footprint. The sample selected for this study was the first replicate of the main analysis. That replicate is labeled “_00” and described throughout this report.

The spreadsheet *ResultsPrelimCase_00_amr.xls* (described in Appendix B) contains the development of the base case for this replicate, within an annotated worksheet tab titled “Valid_TD_00” appended to the end. After identifying cases in which the thickest dike intersects the repository, the number of valid dike cases drops from 152 to 100. Given that the number of valid conduit cases for this replicate remains unchanged at 30, then a new ECP for this replicate becomes 0.3, compared to the original value for this replicate of about 0.2. This is roughly a 50% increase.

If that 50% increase is applied to the final calculated value of ECP of 0.28 (which incorporated all four replicates), then the new value rises to approximately 0.43. That value of 0.43 compares favorably with the value of 0.56 just described. This comparison is consistent with expectations given the many factors that play an independent role in the development of ECP.

6.4.3 Numerical Uncertainties

In the case of the use of the stochastic feeds to the DIRECT code, there is also numerical uncertainty associated with the values of the random-number seeding as part of the LHS activity.

The analysis was broken into four individual replicates, as described throughout the report and notably in the previous section. Each replicate of 1,000 samples was generated from LHS inputs based on a different random seed per replicate. Due to the treatment of magma flooding, there is no variation in the results of the igneous intrusion CDF due to random number seeding. However the CDF for the eruptive conduit case has variable results for each seed, as shown in Table 6-4. In addition, the uncertainty in ECP results due to random seed value is summarized in Table 6-5. No further claims to quantification of uncertainty treatment are made.

Table 6-4. Number of Waste Packages Hit by Eruptive Conduits as a Function of Replicate Number

Replicate Number	Median Number of Waste Packages Hit ^a	Maximum Number of Waste Packages Hit ^a
1	0	5
2	0	5
3	0	6
4	0	7
Composite of all four replicates (the results shown in Figure 7-2).	0	7

^a Output DTN: SN0701PAWPHIT1.001, worksheet "amrNwphEruptive_a" of spreadsheet *ConduitsECP_and_ConduitsWPH_amr.xls*.

Table 6-5. Eruptive Center Probability Calculated by Replicate Subpopulation

Replicate Number	Approximate ECP ^a	
1	0.20	
2	0.34	
3	0.24	
4	0.33	
Composite of all four replicates.	0.28	Standard deviation of replicate population: 0.068

^a Output DTN: SN0701PAWPHIT1.001, worksheet "amrECPa" of spreadsheet *ConduitsECP_and_ConduitsWPH_amr.xls*.

INTENTIONALLY LEFT BLANK

7. CONCLUSIONS

7.1 SUMMARY

This report documents an analysis of the number of waste packages that could be damaged in a potential future igneous event intersecting a repository at Yucca Mountain. The analyses consider the igneous intrusion scenario and the igneous eruption scenario.

The analysis draws stochastically from numerous igneous parameter distributions to create sets of plausible intersections between the repository and dikes with conduits. This leads to the development of outputs of the number of waste packages that could be affected by each of the two igneous scenarios. The parameter **Num_WPs_Hit_Intrusive_a** captures the results for numbers of waste packages hit under the igneous intrusion scenario. The parameter **Num_WPs_Hit_Eruptive_a** captures the results for numbers of waste packages hit under the igneous eruption scenario. In addition, the parameter, **Eruptive_Center_Probability_a**, relates the frequency of eruptive centers that intersect the repository to the frequency of intrusive events that intersect the repository.

7.2 ANALYSIS OUTPUT AND RATIONALE

A plot of the intrusive case CDF (TSPA parameter **Num_WPs_Hit_Intrusive_a**) is included in Figure 7-1. After screening logic is applied, the total number of samples used to create this CDF is 564. There are 16 cases in which dikes intersect the repository footprint but do not touch any drifts. These are treated identically to the remaining cases, and subsequently all valid cases are considered to hit the entire inventory. Therefore, the median number of waste packages hit for the intrusive compliance case is 11,629.

The CDF can be easily approximated in use by the number 1 (to represent fraction of total number of waste packages hit), provided sufficient justification is given.

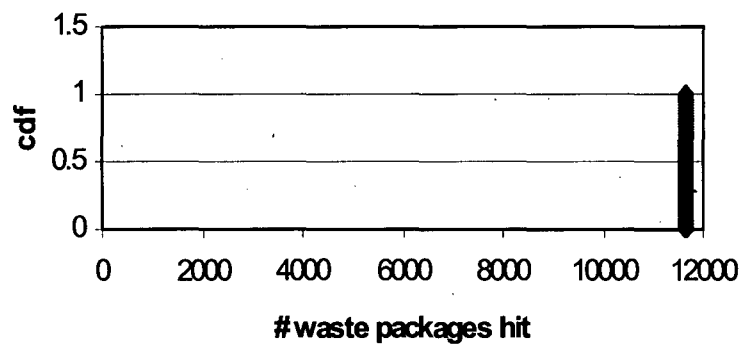

Output DTN: SN0701PAWP HIT1.001, file: *Num_WPs_Hit_Intrusive_amr.xls*.

Figure 7-1. Number of Waste Packages Hit, Intrusive Compliance Case

A plot of the eruptive case CDF (TSPA parameter **Num_WPs_Hit_Eruptive_a**) is included in Figure 7-2. After screening logic was applied, the total number of cases used to produce this plot was 155. Of that total, there were 109 cases in which conduits fell within the repository footprint but did not intersect any drifts. As a result, the median number of waste packages hit by eruptive conduits is equal to zero.

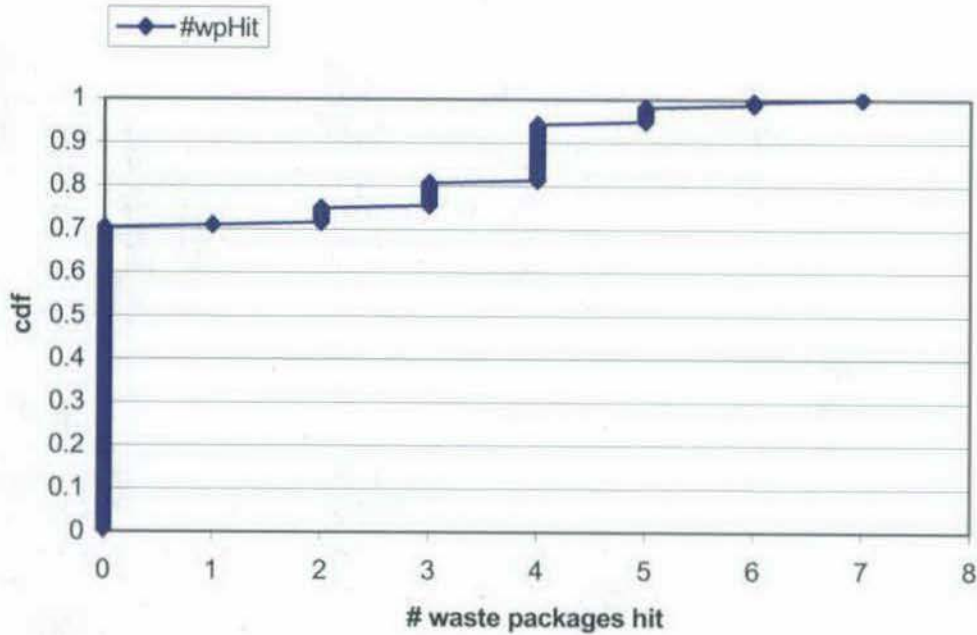

Output DTN: SN0701PAWPHIT1.001, file: *ConduitsECP_and_ConduitsWPH_amr.xls*.

Figure 7-2. Number of Waste Packages Hit by Eruptive Conduits

Eruptive_Center_Probability_a (ECP) is a single value that is used by the TSPA to capture the relative frequency of eruptive cases, compared to the frequency of intrusive cases. The value is calculated as the ratio of the number of valid eruptive cases to the number of valid intrusive cases. Details of this calculation are provided in Section 6.3.4. This ratio is equal to 0.28, after using the Excel “Ceiling” function to set the value of “Round up” to the next highest value in the second decimal.

7.3 PARAMETER VALUES

The parameter output values are described in Table 7-1, except for the values of those parameters that are files. These values can be found in the data tracking number (DTN) identified in the last column of Table 7-1. Also, the two CDFs that represent the files of the first two parameters are illustrated in Figures 7-1 and 7-3 of this report.

7.4 DTN/NAME OR OTHER REFERENCE

The DTN that is used to control and archive the TSPA parameters covered by this report appears in the last column of Table 7-1.

Table 7-1. TSPA Parameters for Number of Waste Packages Hit

Parameter Name	Parameter Definition	Uncertainty Description	Parameter Value(s)	Output DTN/Title/DIRS
Num_WPs_Hit_Intrusive_a	Number of waste packages hit by igneous intrusive event	Stochastic file	worksheet: "amrNwphIntrusive" of spreadsheet: <i>Num_WPs_Hit_Intrusive_amr.xls</i> .	Number of Waste Packages Hit by Igneous Events (output DTN: SN0701PAWPHIT1.001)
Num_WPs_Hit_Eruptive_a	Number of waste packages hit by igneous eruptive event	Stochastic file	worksheet: "amrNwphEruptive_a" of the spreadsheet: <i>ConduitsECP_and_ConduitsWPH_amr.xls</i> .	Number of Waste Packages Hit by Igneous Events (output DTN: SN0701PAWPHIT1.001)
Eruptive_Center_Probability_a	Proportion of calculated intrusive igneous events in which eruptive cases also occur.	Single value	0.28, from worksheet: "021607ECPa" of the spreadsheet: <i>ConduitsECP_and_ConduitsWPH_amr.xls</i>	Number of Waste Packages Hit by Igneous Events (output DTN: SN0701PAWPHIT1.001)

INTENTIONALLY LEFT BLANK

8. REFERENCES

8.1 DOCUMENTS CITED

- 169989 BSC (Bechtel SAIC Company) 2004. *Characterize Framework for Igneous Activity at Yucca Mountain, Nevada*. ANL-MGR-GS-000001 REV 02. Las Vegas, Nevada: Bechtel SAIC Company. ACC: DOC.20041015.0002; DOC.20050718.0007.
- 166107 BSC 2004. *Drift Degradation Analysis*. ANL-EBS-MD-000027 REV 03. Las Vegas, Nevada: Bechtel SAIC Company. ACC: DOC.20040915.0010; DOC.20050419.0001.
- 174070 BSC 2005. *Magma Dynamics at Yucca Mountain, Nevada*. ANL-MGR-GS-000005 REV 00. Las Vegas, Nevada: Bechtel SAIC Company. ACC: DOC.20050829.0006.
- 174066 BSC 2005. *Number of Waste Packages Hit by Igneous Intrusion*. ANL-MGR-GS-000003 REV 02. Las Vegas, Nevada: Bechtel SAIC Company. ACC: DOC.20050829.0001.
- 180434 BSC 2006. *TMRB Decision Proposal, Remove the Requirement for Design and Installation of Magma Bulkheads in the Subsurface Repository*. TMRB-2006-018. Las Vegas, Nevada: Bechtel SAIC Company. ACC: LLR.20070323.0005.
- 178693 BSC 2007. *Subsurface Geotechnical Parameters Report*. ANL-SSD-GE-000001 REV 00. Las Vegas, Nevada: Bechtel SAIC Company. ACC: ENG.20070115.0006.
- 100116 CRWMS M&O 1996. *Probabilistic Volcanic Hazard Analysis for Yucca Mountain, Nevada*. BA0000000-01717-2200-00082 REV 0. Las Vegas, Nevada: CRWMS M&O. ACC: MOL.19971201.0221.
- 182051 DOE (U.S. Department of Energy) 2007. *Quality Assurance Requirements and Description*. DOE/RW-0333P, Rev. 19. Washington, D. C.: U.S. Department of Energy, Office of Civilian Radioactive Waste Management. ACC: DOC.20070717.0006.
- 141885 Guttman, I.; Wilks, S.S.; and Hunter, J.S. 1982. *Introductory Engineering Statistics*. 3rd Edition. New York, New York: John Wiley & Sons. TIC: 246782.
- 163475 Helton, J.C. and Davis, F.J. 2002. *Latin Hypercube Sampling and the Propagation of Uncertainty in Analyses of Complex Systems*. SAND2001-0417. Albuquerque, New Mexico: Sandia National Laboratories. TIC: 254367.
- 109119 Jackson, J.A., ed. 1997. *Glossary of Geology*. 4th Edition. Alexandria, Virginia: American Geological Institute. TIC: 236393.

- 100909 Kotra, J.P.; Lee, M.P.; Eisenberg, N.A.; and DeWispelare, A.R. 1996. *Branch Technical Position on the Use of Expert Elicitation in the High-Level Radioactive Waste Program*. NUREG-1563. Washington, D.C.: U.S. Nuclear Regulatory Commission. TIC: 226832.
- 100297 NRC (U.S. Nuclear Regulatory Commission) 1998. *Issue Resolution Status Report Key Technical Issue: Igneous Activity*. Rev. 0. Washington, D.C.: U.S. Nuclear Regulatory Commission. ACC: MOL.19980514.0576.
- 159538 NRC 2002. *Integrated Issue Resolution Status Report*. NUREG-1762. Washington, D.C.: U.S. Nuclear Regulatory Commission, Office of Nuclear Material Safety and Safeguards. TIC: 253064.
- 163274 NRC 2003. *Yucca Mountain Review Plan, Final Report*. NUREG-1804, Rev. 2. Washington, D.C.: U.S. Nuclear Regulatory Commission, Office of Nuclear Material Safety and Safeguards. TIC: 254568.
- 119693 Reamer, C.W. 1999. "Issue Resolution Status Report (Key Technical Issue: Igneous Activity, Revision 2)." Letter from C.W. Reamer (NRC) to Dr. S. Brocoum (DOE/YMSCO), July 16, 1999, with enclosure. ACC: MOL.19990810.0639.
- 173995 Rocchi, V.; Sammonds, P.R.; and Kilburn, C.R.J. 2004. "Fracturing of Etnean and Vesuvian Rocks at High Temperatures and Low Pressures." *Journal of Volcanology and Geothermal Research*, 132, 137-157. New York, New York: Elsevier. TIC: 257313.
- 145235 Sagar, B., ed. 1997. *NRC High-Level Radioactive Waste Program Annual Progress Report: Fiscal Year 1996*. NUREG/CR-6513, No. 1. Washington, D.C.: U.S. Nuclear Regulatory Commission. ACC: MOL.19970715.0066.
- 165740 Schlueter, J.R. 2003. "Igneous Activity Agreement 2.09, Additional Information Needed." Letter from J.R. Schlueter (NRC) to J.D. Ziegler (DOE/ORD), March 25, 2003, 0331036684, with enclosure. ACC: MOL.20031009.0249.
- 177431 SNL (Sandia National Laboratories) 2007. *Atmospheric Dispersal and Deposition of Tephra from a Potential Volcanic Eruption at Yucca Mountain, Nevada*. MDL-MGR-GS-000002 REV 03. Las Vegas, Nevada: Sandia National Laboratories.
- 174260 SNL 2007. *Characterize Eruptive Processes at Yucca Mountain, Nevada*. ANL-MGR-GS-000002 REV 03. Las Vegas, Nevada: Sandia National Laboratories. ACC: DOC.20070301.0001.
- 177430 SNL 2007. *Dike/Drift Interactions*. MDL-MGR-GS-000005 REV 02. Las Vegas, Nevada: Sandia National Laboratories.

- 179347 SNL 2007. *Redistribution of Tephra and Waste by Geomorphic Processes Following a Potential Volcanic Eruption at Yucca Mountain, Nevada*. MDL-MGR-GS-000006 REV 00. Las Vegas, Nevada: Sandia National Laboratories.
- 182219 SNL 2007. *Technical Work Plan for: Igneous Activity Assessment for Disruptive Events*. TWP-WIS-MD-000007 REV 10. Las Vegas, Nevada: Sandia National Laboratories.
- 179466 SNL 2007. *Total System Performance Assessment Data Input Package for Requirements Analysis for Subsurface Facilities*. TDR-TDIP-PA-000001 REV 00. Las Vegas, Nevada: Sandia National Laboratories.

8.2 CODES, STANDARDS, REGULATIONS, AND PROCEDURES

- 180319 10 CFR 63. 2007 Energy: Disposal of High-Level Radioactive Wastes in a Geologic Repository at Yucca Mountain, Nevada. ACC: MOL.20050405.0118.
- 165519 40 CFR 197. Protection of Environment: Public Health and Environmental Radiation Protection Standards for Yucca Mountain, Nevada. Readily available.
- IM-PRO-003, *Software Management*.
- SCI-PRO-005, *Scientific Analyses and Calculations*.

8.3 SOURCE DATA, LISTED BY DATA TRACKING NUMBER

- 164712 LA0009FP831811.001. Compilation and Summaries of Data Supporting Computation of Volcanic Event Intersection Frequencies. Submittal date: 09/01/2000.
- 179987 LA0612DK831811.001. Physical Parameters of Basaltic Magma and Eruption Phenomena. Submittal date: 03/23/2007.
- 171483 MO0408MWDDDMIO.002. Drift Degradation Model Inputs and Outputs. Submittal date: 08/31/2004.
- 179925 MO0702PASTREAM.001. Waste Stream Composition and Thermal Decay Histories for LA. Submittal date: 02/15/2007.
- 181613 MO0706SPAFEPLA.001. FY 2007 LA FEP List and Screening. Submittal date: 06/20/2007.
- 170993 SN0402T0503102.010. Heat Capacity Values for Lithostratigraphic Layers of Yucca Mountain. Submittal date: 02/24/2004.
- 169129 SN0404T0503102.011. Thermal Conductivity of the Potential Repository Horizon Rev 3. Submittal date: 04/27/2004.

8.4 SOFTWARE CODES

- 161953 FLAC V. 4.0. 2002. WINDOWS 2000/NT 4.0. STN: 10167-4.0-00.
- 167794 LHS V. 2.51. 2004. DEC ALPHA, OPEN VMS AXP 7.3-1. STN: 10205-2.51-00.
- 179574 DIRECT V. 4.0. 2007. WINDOWS XP. STN: 11121-4.0-00.
- 155082 CORPSCON V. 5.11.08. 2001. WINDOWS NT 4.0. STN: 10547-5.11.08-00.

8.5 PRODUCT OUTPUT, LISTED BY DATA TRACKING NUMBER

SN0701PAWPHIT1.001 Number of Waste Packages Hit by Igneous Events.
Submittal date: 09/13/2007.

MO0506SPACRITL.000. Critical Distance Between Dike and Drift Calculations.
Submittal date: 06/20/2005.

APPENDIX A
PREPROCESSING TO DIRECT CODE

APPENDIX A PREPROCESSING TO DIRECT CODE

A.1 REPOSITORY DESIGN INPUTS

This section of the appendix describes the files and supporting calculations that are developed in support of repository representation within the DIRECT V. 4.0 code (STN: 11121-4.0-00 [DIRS 179574]) code. All files are archived in output DTN: SN0701PAWPHIT1.001

DIRECT reads in three geometry files:

1. *DriftData.txt* describes the geometry of each waste emplacement drift.

The single entry in the first row is the average waste-package-and-spacing length in meters. This value is later modified in a postprocessing step.

Each subsequent row defines a single drift. Only one shape segment is necessary to define each emplacement drift.

The first three numbers in a row represent the x, y, and z coordinates, respectively (in DIRECT's internal geometry system, described in Section A1.1, Descriptions for *RepGeometry_Bas07_June.xls*), of the center of the drift.

The next three numbers in the row represent the scaling to be applied in the x, y, and z directions, respectively, for the shape segment that will accurately represent the drift. The y scale values represent the actual emplacement drift lengths in meters. The other scale values correspond to DIRECT's internal geometry system.

The final four numbers define rotations. The first three numbers are logical flags for the x, y, or z axes, respectively. The fourth number is rotation in degrees counter-clockwise, starting from due east. If any flag is labeled 1 instead of zero, then the drift is rotated counter clockwise about that axis by the stated number of degrees.

The entire sequence is repeated until all drifts are addressed.

2. *eDriftData.txt* describes the geometry of each drift turnout and extension segment.

The single entry in the first row is a flag for whether or not these data will actually be used by DIRECT. "1" means to use the data. "0" means not to use the data.

Each subsequent two-row set defines a single drift extension segment and the parent emplacement drift to which it is connected. The first subrow lists the parent drift, and the second subrow represents the drift extension segment geometry. The parent drift numbers used by DIRECT are also provided in column B of the worksheet "DriftExport 07" of the spreadsheet *RepGeometry_Bas07_June.xls*

The first three numbers in the second subrow represent the x, y, and z coordinates, respectively, of the center of the drift segment.

The next three numbers in the subrow represent the scaling to be applied in the x, y, and z directions, respectively, for the drift segment. The y scale values represent the actual emplacement drift lengths in meters. The other scale values correspond to DIRECT's internal geometry system.

The final four numbers define rotations. The first three numbers are logical flags for the x, y, or z axes, respectively. The fourth number is rotation in degrees, counter-clockwise, starting from due east. If any flag is labeled 1 instead of zero, then the drift is rotated counter clockwise about that axis by the stated number of degrees.

The entire sequence is repeated until all drift extension segments are addressed.

3. *repositoryBoundaryData.txt* describes a perimeter around the emplacement drift endpoints. It consists of, first, a number defining the number of coordinate pairs to follow, then one coordinate pair per row, accordingly. The coordinates are in the "Geo" coordinate system.

All files are developed from heavily annotated spreadsheets, which are described in summary fashion below.

A.1.1 Descriptions for *RepGeometry_Bas07_June.xls*

This spreadsheet develops the geometry of the repository emplacement drifts for integration into the DIRECT input files *DriftData.txt* and *repositoryBoundaryData.txt*. It consists of five worksheets: "Orig-07," "scaled down 07," "DriftExport 07," "perimeter," and "Auxiliary." The multi-step process is necessary in order to produce geometry in both the Torque Game Engine (TGE) coordinate system, and the "Geo" coordinate system, which is the primary system used for representations in this analysis.

The "Orig-07" worksheet contains a tabulation of the bounding endpoints in Nevada state plane (NSP) coordinates (in meters) for each repository drift, as well as calculations of drift length (m). Due to narrow proximities between the top nine drifts of Panels 3w and 4, there is no rationale to assume any effective barriers between the adjacent drifts. Therefore, in these drifts, the nine adjacent pairs of 3w and 4 elements are combined into nine single drifts. This condition is highlighted by blue arrows in Figure 6-1.

The "scaled down 07" worksheet contains tabulations of the previous worksheet values. To facilitate an origin with a y and x axis viewable near the repository, the NSP coordinates are transformed to produce the "Geo" coordinate system. In this system, 170,000 is subtracted from all NSP x values and 231,000 is subtracted from all NSP y values. Also, the midpoint of each drift in these transformed coordinates is tabulated. Equations A-1 and A-2 represent the formal transformations to "Geo" coordinates.

$$X_{\text{Geo}} = X_{\text{NSP}} - 170,000 \quad (\text{Eq. A-1})$$

$$Y_{\text{Geo}} = Y_{\text{NSP}} - 231,000 \quad (\text{Eq. A-2})$$

where:

X_{Geo} is the X "Geo" coordinate value in meters

Y_{Geo} is the Y "Geo" coordinate value in meters

X_{NSP} is the X NSP coordinate value in meters, and

Y_{NSP} is the Y NSP coordinate value in meters

The "DriftExport 07" worksheet continues the transformation to the TGE system and contains geometric descriptions suitable (if directions are followed) for producing *DriftData.txt*, which is an input to the DIRECT code. In this final transformation, the coordinates and scale are reconciled with the underlying DIRECT game engine geometry. First, 1,000 is subtracted from all "Geo" coordinate values and the remaining difference is divided by 100. The displays from DIRECT, such as those shown in Figures 6-6 through 6-9, are still viewable in "Geo" scale, such that every grid square represents 500 m to a side.

$$X_{TGE} = (X_{Geo} - 1,000)/100 \quad (\text{Eq. A-3})$$

$$Y_{TGE} = (Y_{Geo} - 1,000)/100 \quad (\text{Eq. A-4})$$

where:

X_{TGE} is the X TGE coordinate value in TGE scale

Y_{TGE} is the Y TGE coordinate value in TGE scale

The "perimeter" worksheet contains coordinates in the "Geo" coordinate system that define a perimeter around the collection of drifts. Those coordinates can then be pasted into *repositoryBoundaryData.txt*. It should be noted that this perimeter is not used by DIRECT other than for display convenience. The "Auxiliary" worksheet contains calculations used for preliminary verification of some of the geometry inputs. It also contains the calculation of the average waste-package-and-spacing length, in meters, which is the first entry in *DriftData.txt*.

A.1.2 Descriptions for *RepGeometryTurnoutsVents07b.xls*

This spreadsheet develops the geometry of the repository emplacement drift extensions and turnouts for integration into the DIRECT input file *eDriftData.txt*. It consists of four worksheets: "PreBuild," "Build," "Export 07full" (not used), and "Export 07 short."

The "PreBuild" worksheet addresses the fact that in the top nine drifts of panels 3w and 4, there is no rationale to assume any effective barriers between the adjacent drifts. Therefore in these drifts, the adjacent 3w and 4 elements are combined.

The "Build" worksheet is used to represent each turnout by up to four subsegments, and each extension by one segment. These representations are approximate, and the underlying patterns were developed through trial and error and checked by visual examination (see Figure 6-1).

The "Export 07full" worksheet is not used.

The "Export 07 short" worksheet continues the transformation to the TGE system and contains geometric descriptions suitable (if directions are followed) for producing *eDriftData.txt*, which is an input to the DIRECT code.

A.2 DETAILS OF STOCHASTIC IGNEOUS FEEDS

Details of each input file for this topic are provided in this section of the appendix. The first input file of interest is *DikeCentroidXY.txt*, which defines the centroid location of each sampled dike swarm. This is a simple text file containing one x coordinate and one y coordinate per row. There are at least as many rows as there are samples for the replicate with which this file is associated.

There are four versions of this file, one for each replicate defines all of the dike swarm centroid positions that are plotted in Figure 6-4. These files are archived as *DikeCentroidXY_freeze_##.txt*, where ## stands for the replicate number. The files are generated within the spreadsheet *DikeSeeds_07.xls*

This spreadsheet consists of seven worksheets defined in Table A-1.

Table A-1. The Seven Worksheets of *DikeSeeds_07.xls*

Worksheet ID	Description
"UTMtoNSP"	Documents use of CORPSCON V. 5.11.08 software to convert UTM values of expected volcanic event frequency locations (DTN: LA0009FP831811.001 [DIRS 164712], file: <i>CFRACSM.XY</i>) to NSP coordinates
"NSP_sourceCoords"	Develops the final subset of coordinates to use from <i>CFRACSM.XY</i> (DTN: LA0009FP831811.011 [DIRS 164712]), based on anticipated maximum dike lengths
"SeedReplicator"	Uses the Excel RANDBETWEEN function to produce a set of over 1,000 dike swarm centroid coordinates which honor the probability subset or "NSP_sourceCoords." The number of times this function is employed per 1,000-m by 1,000-m cell is dictated by the corresponding volcanic event frequency.
"freeze_00"	The first case of "SeedReplicator" results is pasted here, with the random function de-activated. Afterwards, these results, in "Geo" coordinates, are pasted into <i>DikeCentroidXY_freeze_00.txt</i> (which ultimately feeds to DIRECT as file <i>DikeCentroidXY.txt</i>).
"freeze_01"	The second case of "SeedReplicator" results is pasted here, with the random function de-activated. Afterwards, these results, in "Geo" coordinates, are pasted into <i>DikeCentroidXY_freeze_01.txt</i> (which ultimately feeds to DIRECT as file <i>DikeCentroidXY.txt</i>).
"freeze_02"	The third case of "SeedReplicator" results is pasted here, with the random function de-activated. Afterwards, these results, in "Geo" coordinates, are pasted into <i>DikeCentroidXY_freeze_02.txt</i> (which ultimately feeds to DIRECT as file <i>DikeCentroidXY.txt</i>).
"freeze_03"	The fourth and last case of "SeedReplicator" results is pasted here, with the random function de-activated. Afterwards, these results, in "Geo" coordinates, are pasted into <i>DikeCentroidXY_freeze_03.txt</i> (which ultimately feeds to DIRECT as file <i>DikeCentroidXY.txt</i>).

As stated in first entry of Table A-1, the CORPSCON V. 5.11.08 software was used to produce the converted NSP coordinate values. The files associated with this conversion exercise are all stored in the folder CORPSCON io and are described below:

Wallace_20061211_2.in – The ASCII input file, containing multiple rows of data. Each row lists a record number followed by the X and the Y UTM coordinate.

Wallace_20061211_2.out – The ASCII output file, containing multiple rows of data. Following the first four lines of run identification information, each row lists a record number followed by the X and the Y NSP coordinate.

Wallace_20061211_2.txt – The ASCII run log file, providing various feedback information on the results of the run.

The number of samples per replicate, among other parameters for each dike swarm and associated conduits, is defined in the input file *lhs.dat*, shown in Figure A-1 below. Other than the initial nine lines, these files are developed through the software code LHS V. 2.51. Each replicate case of this file is stored as *lhs_rep#c.dat*, where “#” stands for the replicate number.

As Figure A-1 shows, there are five entries each for dike thickness and dike halo (red and green respectively) and therefore, only four entries (purple) are needed to define the spacing between each dike.

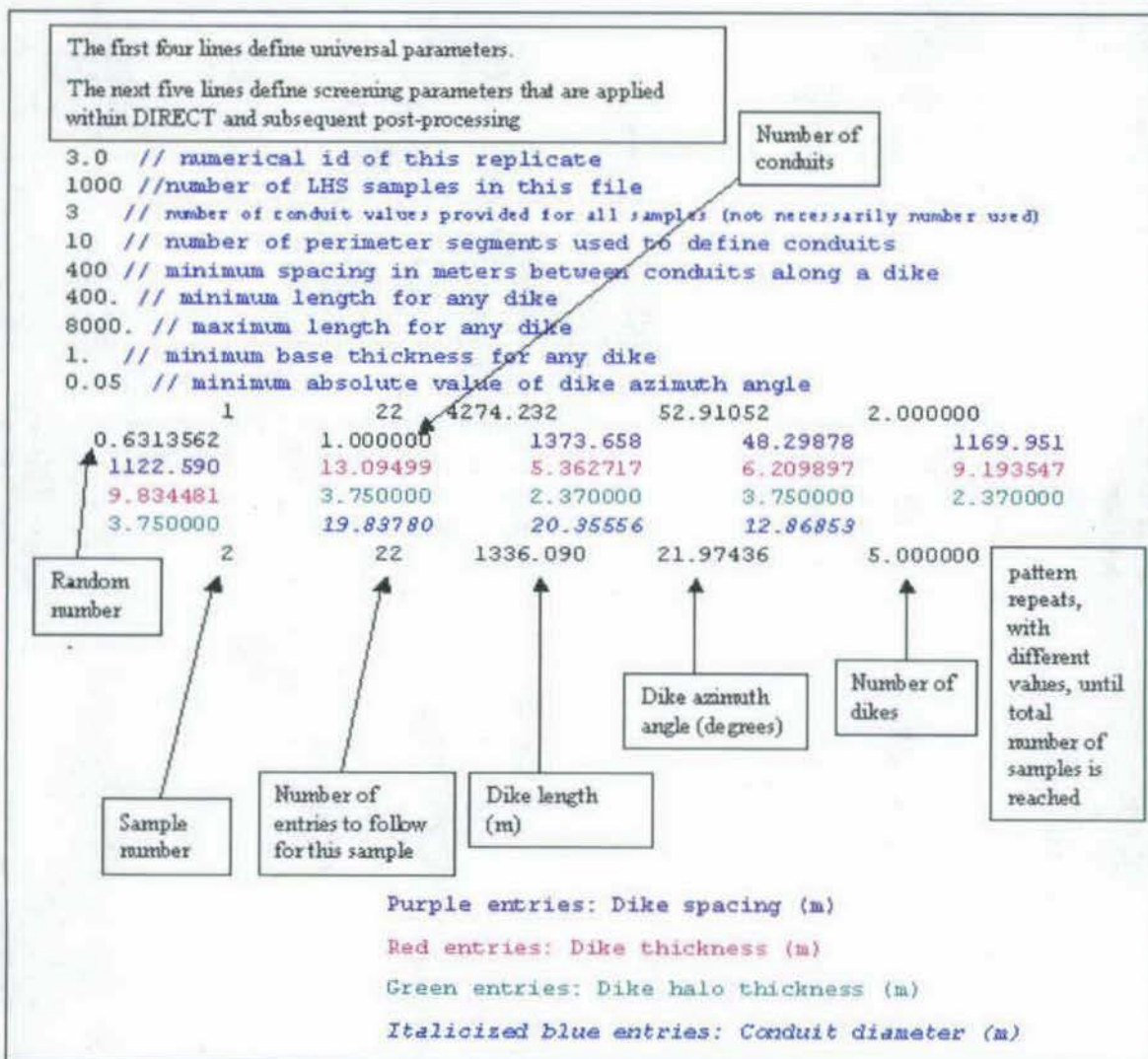

Adapted from Output DTN: SN0701PAWP HIT1.001.

NOTE: This graphic must be viewed in color to ensure correct legend mapping.

Figure A-1. Description of *lhs.dat* Input File to DIRECT

The input file to LHS is labeled *lhs4_uif\$input.dat*. This input data file uses keywords starting in the first column of a line to identify the line or lines of data for each input block. The input file starts with two lines of title information with the keyword "TITLE" at the start of each line. The title information is followed by the number of observations or samples following the keyword "NOBS." The fourth line indicates the number of replicates. The fifth line of input is a seed for the random number generator following the keywords "RANDOM SEED."

It should be noted that some excess results were created (1,100 per replicate, versus the first 1,000 per replicate actually used). That excess was deliberate, in the eventuality that not enough valid samples would result to produce acceptable CDFs for TSPA feeds. If that were to occur, the analysts would have the option to run those remaining cases. This did not turn out to be necessary, so those extra samples are extraneous. The resulting set of 1,000 cases is expected to adequately capture the original distribution

The probability distributions follow the first four lines of input. Each distribution type is identified by one of the following keywords: "BETA," "EXPONENTIAL," "LOGNORMAL," "LOGSTUDENT," "LOGUNIFORM," "NORMAL," "RAYLEIGH," "RAYLEXP," "STUDENT," "TRIANGULAR," "UNIFORM," or "USER DISTRIBUTION."

The distribution type is followed by two words that uniquely identify the variable. A distribution is sampled by choosing "NOBS" values from equally sized "NOBS" intervals for the cumulative probability distribution. Each sampled value is chosen randomly from within each interval. "NREPS" defines the number of replicates of "NOBS" values. Four replicates are therefore used, and each replicate initially has 1,100 values.

It should be noted that for a discrete distribution, only the specified values are possible sampled values. For a continuous distribution, all values between the starting and ending values are possible sampled values.

The first distribution used for DIRECT is the probability distribution of the dike lengths and azimuths. The distribution is a "NORMAL" distribution and the variable name is "DIKE LENGTH." The second line of the "NORMAL" distribution gives the first percentile value and 99th percentile value (see end of this section for a description of how these values are obtained). The second distribution used for DIRECT is the probability distribution of the dike azimuths. The distribution is a "USER DISTRIBUTION" and the variable name is "DIKE AZIMUTH." The second line of "USER DISTRIBUTION" gives the number of data points (19) and specifies that the probability data is continuous ("CONTINUOUS").

The third sampled variable is the number of dikes. The distribution is identified by the line "USER DISTRIBUTION DIKE COUNT." The dike count distribution consists of five specified discrete values of dike count and probability.

The fourth distribution is a uniform distribution for a random seed. This is only developed as a convenience, should such a random number be needed by DIRECT. For the current analysis, this random value is not used.

The fifth distribution specifies tabular probabilities for the sampled number of conduits. The distribution is identified by the line "USER DISTRIBUTION CONDUIT COUNT." The conduit count distribution consists of three specified discrete values of conduit count and probability.

The next four distributions give the spacing between the five dikes. The first spacing distribution is identified by the line "UNIFORM DIKE SPACING1." The final spacing distribution is identified by the line "UNIFORM DIKE SPACING4." The second line of each distribution indicates that the spacing is sampled uniformly on the interval from 0.5 to 1500 meters.

The next five distributions give the core dike widths of the five dikes. The first spacing distribution is identified by the line "NORMAL DIKE WIDTH1." The final spacing distribution is identified by the line "NORMAL DIKE WIDTH5." The second line of the "NORMAL" distribution gives the first percentile value and 99th percentile value (see end of this section for a description of how these values are obtained).

The next five distributions give the proximity factors (halos) of the five dikes. The first spacing distribution is identified by the line "USER DISTRIBUTION HALO THICKNESS1." The final spacing distribution is identified by the line "USER DISTRIBUTION HALO THICKNESS5." The following four lines of each distribution indicate that the proximity value is sampled from a discrete set of three possibilities, each with its own probability. These values are developed within Appendix G, as seen in Table G-5.

The next three distributions give the sampled diameters of each of the three conduits. The first diameter distribution is identified by the line "NORMAL CONDUIT DIAMETER1." The final spacing distribution is identified by the line "NORMAL CONDUIT DIAMETER3." The second line of the "NORMAL" distribution gives the first percentile value and 99th percentile value (see end of this section for a description of how these values are obtained).

The distributions are followed by a line of output options started by the keyword "OUTPUT." The three output options specified are "CORR" (correlations), "HIST" (histograms), and "DATA" (sampled data listings). The correlation output gives rank correlations of the sampled variables. The rank correlations range from -1 to 1, and values near zero (typically between -0.2 and 0.2) indicate that the grouping of sampled variables shows no strong rank correlations.

The LHS input data end with a repetition of the two title lines.

A.3 DEVELOPMENT OF 1ST AND 99TH PERCENTILES FROM OTHER MOMENT VALUES OF THE NORMAL DISTRIBUTION.

The LHS code is pre-conditioned to read in a 99th or a 1st percentile to help define the input normal distribution. Some of the normal igneous inputs to this analysis are defined in part by either the 95th percentile or the 5th percentile.

Due to the definition of a normal distribution, any subsequent percentile value, even a negative one, can be computed. Standard transformations were used to produce the necessary 1st and/or 99th percentiles for use in the LHS code.

Figure 7.2.1 of the text *Introductory Engineering Statistics* (Guttman et al. 1982 [DIRS 141885]) describes a relationship between the standard normal variable and the normally distributed variable, along with its mean and standard deviation through the inclusion of an equation reproduced below:

$$Z = (x - \mu) / \sigma \quad (\text{Eq. A.1})$$

where

- Z = the standard normal variable,
- x = the normal variable
- μ = the mean of the normal distribution, and
- σ = the standard deviation of the normal distribution

This relation ensures that when $Z = 1$, then $x - \mu = \sigma$. Also, when $Z = 2$ then $x - \mu = 2 \sigma$, and so on. In other words, Z measures the distance from the mean in units of multiples of the standard deviation.

With this equation and the associated Table II which covers Z versus the percentile value (Guttman et al., 1982 [DIRS 141885]), one can simply calculate the 99th or the 1st percentile.

For example, the distribution of dike lengths is given in Table 4-1, in part, as a normal distribution, mean of 2 km, 95th percentile of 6 km. Therefore x_{95} is 6,000 m and μ is 2,000 m.

Note that σ is constant for a normal distribution; therefore Equation A.1 can be modified and then directly used for the 95th percentile to calculate the 99th as shown below.

$$\sigma = (x - \mu) / Z \quad (\text{Eq. A.2})$$

Then comparing the relation for the 99th percentile with the relation for the 95th percentile yields

$$(x_{95} - \mu) / Z_{95} = (x_{99} - \mu) / Z_{99} \quad (\text{Eq. A.3})$$

Then x_{99} can then be directly solved algebraically.

$$x_{99} = (Z_{99} * (x_{95} - \mu) / Z_{95}) + \mu \quad (\text{Eq. A.4})$$

For the 95th percentile value, Z approximately equals 1.645.

For the 99th percentile value, Z approximately equals 2.326.

Therefore, $x_{99} = 2.326 * ((6000 - 2000) / 1.645) + 2000 = 7657$

The number 7657 is the value fed to LHS for defining the 99th percentile. The input Table 4-1 also describes a truncation at 8 km. This is moot, since, as stated earlier, LHS does not produce values outside of the 99th percentile. Therefore, given the distribution assigned in Table 4-1, no sampled dike length values will ever exceed 7657 m.

INTENTIONALLY LEFT BLANK

**APPENDIX B
OUTPUT DEVELOPMENT**

APPENDIX B OUTPUT DEVELOPMENT DETAILS

Development of output consists first of DIRECT V. 4.0 output, followed by extensive spreadsheet postprocessing.

DIRECT produces four types of output files described below:

1. The first type includes the primary results of tabulations of numbers of waste packages hit and also of drifts hit under various conditions.
2. The second type includes the screening outputs. These files each describe a logical condition that is tracked for every result case. Certain conditions may ultimately lead to that case being discarded or included in ultimate CDF development.
3. The third type is a log file, and *console.log* is the only file to fit under this category. This file gives detailed textual information on the setup and results of each case considered.
4. The final file type is an image file, in the .png format. This file is a screenshot display of a sample case.

All relevant DIRECT output files are described below. Each numerical designation associates the file with the respective replicates, labeled 00, 01, 02, or 03. All files are archived in output DTN: SN0701PAWPHIT1.001

Table B-1. DIRECT V4.0 Output Files

DIRECT Output File and Type	Description
<i>wph_conduit_results_00.txt</i> <i>wph_conduit_results_01.txt</i> <i>wph_conduit_results_02.txt</i> <i>wph_conduit_results_03.txt</i> type 1	The four <i>wph_conduit_...</i> files are outputs from four runs of DIRECT V. 4.0. They each contain a listing of numbers of waste packages hit by eruptive conduits for each case considered. There are 1,000 numbers (results) per file.
<i>wph_dike_results_00.txt</i> <i>wph_dike_results_01.txt</i> <i>wph_dike_results_02.txt</i> <i>wph_dike_results_03.txt</i> type 1	The four <i>wph_dike_...</i> files are outputs from four runs of DIRECT V. 4.0. They each contain a listing of numbers of preliminary waste packages hit by vertical tabular dikes for each case considered and are used in the compliance consideration by capturing the cases in which a dike intersects the repository. There are 1,000 numbers (results) per file.
<i>drift_conduit_results_00.txt</i> <i>drift_conduit_results_01.txt</i> <i>drift_conduit_results_02.txt</i> <i>drift_conduit_results_03.txt</i> type 1	The four <i>drift_conduit_...</i> files are outputs from four runs of DIRECT V 4.0. They each contain a listing of numbers of drifts hit by eruptive conduits for each case considered. There are 1,000 numbers (results) per file. These are not used directly in analysis but are useful for spot confirmations.
<i>drift_dike_results_00.txt</i> <i>drift_dike_results_01.txt</i> <i>drift_dike_results_02.txt</i> <i>drift_dike_results_03.txt</i> type 1	The four <i>drift_dike_...</i> files are outputs from four runs of DIRECT V. 4.0. They each contain a listing of numbers of drifts hit by vertical tabular dikes for each case considered, under the performance margin analysis consideration. There are 1,000 numbers (results) per file. These are not used directly in analysis but are useful for spot confirmations.
<i>concapture_00.txt</i> <i>concapture_01.txt</i> <i>concapture_02.txt</i> <i>concapture_03.txt</i> type 2	The four <i>concapture_...</i> files are also outputs from four runs of DIRECT V. 4.0. They each contain a listing of a flag variable for each case considered. The flag indicates whether or not a conduit falls within a rough rectangle approximating the repository. There are 1,000 numbers (results) per file. They are described in detail in supporting spreadsheets.

Table B-1. DIRECT Output Files (Continued)

DIRECT Output File and Type	Description
<i>ConSpaceFail_00.txt</i> <i>ConSpaceFail_01.txt</i> <i>ConSpaceFail_02.txt</i> <i>ConSpaceFail_03.txt</i> type 2	The four <i>ConSpace...</i> files are also outputs from four runs of DIRECT V. 4.0. They each contain a listing of a flag variable for each case considered. The flag indicates whether or not conduit spacing conditions were met. There are 1,000 numbers (results) per file. They are described in detail in supporting spreadsheets.
<i>DikeAzFail_00.txt</i> <i>DikeAzFail_01.txt</i> <i>DikeAzFail_02.txt</i> <i>DikeAzFail_03.txt</i> type 2	The four <i>DikeAzFail...</i> files are also outputs from four runs of DIRECT V. 4.0. They each contain a listing of a flag variable for each case considered. The flag indicates whether or not minimal dike azimuth conditions were met. There are 1,000 numbers (results) per file. They are described in detail in supporting spreadsheets.
<i>DikeFail_00.txt</i> <i>DikeFail_01.txt</i> <i>DikeFail_02.txt</i> <i>DikeFail_03.txt</i> type 2	The four <i>DikeFail...</i> files are also outputs from four runs of DIRECT V. 4.0. They each contain a listing of a flag variable for each case considered. The flag indicates whether or not minimal dike geometry conditions were met. There are 1,000 numbers (results) per file. They are described in detail in supporting spreadsheets.
<i>console_00.log</i> <i>console_01.log</i> <i>console_02.log</i> <i>console_03.log</i> type 3	The four <i>console_...</i> files are also outputs from four runs of DIRECT V. 4.0. They each contain annotated listings of important parameters and variables for each case considered. See Appendix C for additional information.
<i>dikeset_0####.png</i> type 4	The graphic output(s) for each case. Two graphics per case are provided, one at a remote scale and one on a more standard scale. One folder of files is provided for each scale, for each replicate. Replicate number is provided in each graphic, and in each parent folder.

DIRECT output of types 1 and 2 is postprocessed in the following four spreadsheets, which each correspond to a different replicate:

- *ResultsPrelimCase00_amr.xls*
- *ResultsPrelimCase01_amr.xls*
- *ResultsPrelimCase02_amr.xls*
- *ResultsPrelimCase03_amr.xls*

The postprocessing spreadsheets cover the three primary purposes listed below:

1. Apply all screening criteria described in Table 6-3
2. Produce preliminary CDF data for eruptive case
3. Produce preliminary CDF data for intrusive compliance case.

The four spreadsheets are largely identical in structure. Each is initially subdivided into four sub-worksheets (tabs) with the following descriptions:

Table B-2. The Four Worksheets of *ResultsPrelimCase0#d.xls*

Tab ID (worksheet)	Description
"RawCases_0#"	From replicate 0#, the DIRECT output files <i>wph_dike_results_0#.txt</i> , <i>whp_conduit_results_0#.txt</i> , <i>concapture_0#.txt</i> , <i>ConSpaceFail_0#.txt</i> , <i>DikeFail_0#.txt</i> , and <i>DikeAzFail_0#.txt</i> are pasted into this worksheet as a starting point.
"ValidCases_0#"	After the screening criteria of Table 6-3 are applied, this is what remains of the samples.
"ValidConduitCases_0#"	Follow-up work to produce a sub-CDF for this replicate for the eruptive case.
"ValidDikeCasesCompl_0#"	Follow-up work to produce a sub-CDF for this replicate for the intrusive compliance case.

The final spreadsheets, which contain the TSPA parameter values, draw from the above four preliminary spreadsheets.

The first primary TSPA output is a tabular CDF representing the parameter **Num_WPs_Hit_Intrusive_a**, contained in worksheet "amrNwphIntrusive" of the spreadsheet *Num_WPs_Hit_Intrusive_amr.xls*.

The second primary output is a tabular CDF representing the parameter **Num_WPs_Hit_Eruptive_a**, contained in worksheet "amrNwphEruptive_a" of the spreadsheet *ConduitsECP_and_ConduitsWPH_amr.xls*.

The final primary output is a single number representing the parameter **Eruptive_Center_Probability_a**, contained in worksheet "amrECPa" of the spreadsheet *ConduitsECP_and_ConduitsWPH_amr.xls*.

All spreadsheets are extensively annotated.

In addition, an uncertainty analysis was conducted in worksheet "Valid_TD_00" in spreadsheet *ResultsPrelimCase00_amr.xls*. The worksheet is sufficiently annotated for traceability. It explores a different means for representing the parameter **Eruptive_Center_Probability_a**.

INTENTIONALLY LEFT BLANK

APPENDIX C
DESCRIPTION OF MINOR INPUT DISCREPANCIES

APPENDIX C DESCRIPTION OF MINOR INPUT DISCREPANCIES

This appendix describes and documents a minor discrepancy between data used in this report and data feeds from another report. It also documents two output errors in a log file which is not used by any other calculation or analysis. Discrepancies have been found with regard to the following three parameters:

1. Repository drift coordinates (all values)
2. Incorrect flag message in console.log file
3. Incorrect input file descriptor in console.log file.

These discrepancies have all been determined to be inconsequential. The description and evaluation of each discrepancy follows.

C.1 REPOSITORY DRIFT ENDPOINT VALUES

The coordinate values used for emplacement drift endpoints, as shown in worksheet "Orig-07" of spreadsheet *RepGeometry_Bas07_June.xls*, are listed to a higher degree of precision than the current source provides. Nonetheless, the values are essentially correct, so no further corrections are necessary.

C.2 INCORRECT FLAG MESSAGE IN *CONSOLE.LOG* FILE

The file *console.log* is an auxiliary output file that is not used in subsequent data development or analysis. It is primarily used by DIRECT programmers during code development to display various code states of interest. The current discrepancy relates to the fact that when a sampled case has a dike azimuth that is sufficiently close to zero, then that is reported (correctly) in the file *DikeAzFail.txt*. However, the *console.log* reports incorrectly that the angle will be reset to an acceptable value by DIRECT. This resetting is never done. Instead, the case is discarded and not used further.

C.3 INCORRECT FILE REFERENCE IN *CONSOLE.LOG* FILE

The file *console.log* is an auxiliary output file that is not used in subsequent data development or analysis. It is primarily used by DIRECT programmers during code development to display various code states of interest. The current discrepancy relates to the fact that the log file reports that a shape file *diketest1.dts* is used in some instances. In fact, only the *diketest2.dts* is used in those cases.

INTENTIONALLY LEFT BLANK

APPENDIX D
INTERMEDIATE STEPS IN THE DEVELOPMENT OF *DIRECT* SIMULATIONS

APPENDIX D
INTERMEDIATE STEPS IN THE DEVELOPMENT OF *DIRECT* SIMULATIONS

SUPPLEMENTAL DETAILS ON *DIRECT* INPUT FILES AND RUNTIME PARAMETERS

Input Files

DIRECT, for visualization purposes only, expects every object to be defined by its initial shape file definition, the midpoint coordinates of the shapefile object, the scaling in the x, y, and/or z axis of the shapefile object, and the rotations of the shapefile object around the x, y, and/or z axes, centered at its midpoint. For drifts, the shape definitions are set up in the spreadsheet *RepGeometry07.xls* and realized in the DIRECT input file, *driftData.txt*. For dikes, the shape definitions are set up in the output file from the LHS run, which is input into DIRECT, which produces a separate intermediate input file, *dikeData.txt* (these three actions are discussed in Appendix A).

Production of shapefiles is a multistep process:

1. In the 3-D computer-aided design program, Rhinoceros (or an alternate computer-aided design program), construct a unit prism for initial drift geometry.
2. Export the unit prism as an Alias|Wavefront .obj file (this is simply a format that Rhinoceros can write and MilkShape can read).
3. Import the .obj file into MilkShape. (MilkShape has its own drawing capability but does not offer the degree of precision control that Rhinoceros does.)
4. Export the file from MilkShape into the .dts format (*diketest2.dts*, for example), also known as a shapefile. The object's initial orientation and dimensions are such that it has a unit length in the y axis direction.
5. Place the shapefile object into the appropriate directory (example\data\shapes\organic).
6. Repeat the process to produce a unit prism for all sampled dikes.

The development of the transformation parameters applied to the drift shapefile is another multi-step process:

1. Start with original drift coordinates ("original" worksheet of *RepGeometry07.xls*) (Appendix A).
2. Transform scale and position (by first dividing both coordinates by 100, then subtracting 1,710 from the x coordinate and 2,320 from the y coordinate) and confirm the 72 degree azimuth angle ("scaled down" worksheet of *RepGeometr07.xls*) (Appendix A).

3. Produce a transformation instruction file (*driftData.txt*) for input to DIRECT ("DriftExport" worksheet of *RepGeometry07.xls*) (Appendix A).

For all dike sets, DIRECT automatically produces the appropriate transformation parameters and the transformation instruction file based on the file from the LHS step.

Runtime Parameters

DIRECT has automatic and custom viewing features. In automatic mode, DIRECT produces a single file containing all results, but no figures for verification assistance. To set the runs for automatic mode, the user currently must enter the command line: `direct.exe -dedicated` in an MS-DOS window that is set to the same directory as the DIRECT executable.

In custom mode, which is the default setup, the user can examine one case at a time. When the code is launched, the first set is shown on the screen. The user can advance one set at a time by pressing the right arrow key. The user can go backward one step at a time by pressing the left arrow key. The user can skip to any of the steps (out of 1,000) by pressing the `ctrl + j` keys simultaneously and entering the desired step number.

The graphic from that case can then be saved as a .png file for storage and/or printing. The file is saved by simultaneously pressing the `ctrl` and `p` keys to create an image file in .png format in the examples directory. Within DIRECT, the image can be zoomed in or out by pressing the `e` and `c` keys respectively. The image can be panned right or left by pressing the `d` and `a` keys, respectively. The image can be panned up or down by pressing the `w` and `x` keys, respectively. The user can set DIRECT to automatically produce a sequential series of step plots for the current view by pressing the space bar. Pressing the space bar again will toggle out of that mode.

APPENDIX E
APPLICABLE YMRP ACCEPTANCE CRITERIA

APPENDIX E APPLICABLE YMRP ACCEPTANCE CRITERIA

E.1 BACKGROUND

Early in 1995, the NRC recognized the need to refocus its prelicensing repository program on resolving issues most significant to repository performance. In 1996, the NRC identified 10 key technical issues (Sagar 1997 [DIRS 145235]) intended to reflect the topics that the NRC considered most important to repository performance. Nine of the issues were technical, and the tenth concerned the development of the dose standard for a repository at Yucca Mountain (see 40 CFR Part 197 [DIRS 165519]). The technical issues included igneous activity, and the status of resolution of each issue and associated open items were described by the NRC in a series of Issue Resolution Status Reports (e.g., Reamer 1999 [DIRS 119693]). In 2002, the NRC consolidated the subissues into a series of integrated subissues and replaced the series of nine issue resolution status reports with *Integrated Issue Resolution Status Report* (NRC 2004 [DIRS 159538]). Development of *Integrated Issue Resolution Status Report* (NRC 2004 [DIRS 159538]) was based on the realization that the issue resolution process was "mature enough to develop a single Integrated Issue Resolution Status Report that would clearly and consistently reflect the interrelationships among the various key technical issue subissues and the overall resolution status" (NRC 2002 [DIRS 159538], pp. xviii and xix). *Integrated Issue Resolution Status Report* (NRC 2002 [DIRS 159538]) and periodic letters from the NRC (e.g., Schlueter 2003 [DIRS 165740]) provide information about the resolution status of the integrated subissues that are described in the *Yucca Mountain Review Plan, Final Report* (NRC 2003 [DIRS 163274]).

E.2 IGNEOUS ACTIVITY KEY TECHNICAL ISSUE

The key technical issue for igneous activity was defined by the NRC staff as "predicting the consequence and probability of igneous activity affecting the repository in relationship to the overall system performance objective" (NRC 1998 [DIRS 100297], p. 3). Hence, the NRC defined two subissues for the igneous activity key technical issue: probability and consequences (NRC 1998 [DIRS 100297], p. 3). The probability subissue addresses the likelihood that future igneous activity would disrupt a repository at Yucca Mountain. The DOE estimated the probability of future disruption of a repository at Yucca Mountain in *Probabilistic Volcanic Hazard Analysis for Yucca Mountain, Nevada* (CRWMS M&O 1996 [DIRS 100116]). For the TSPA, an analysis based on results from *Probabilistic Volcanic Hazard Analysis for Yucca Mountain, Nevada* and consideration of the repository design were both updated and documented in *Characterize Framework for Igneous Activity at Yucca Mountain, Nevada* (BSC 2004 [DIRS 169989]).

The consequences subissue examined the effects of igneous activity on various engineered and natural components of the repository system. The consequences subissue comprises four integrated subissues:

- Mechanical disruption of engineered barriers (NRC 2003 [DIRS 163274] Section 2.2.1.3.2)

- Volcanic disruption of waste packages (NRC 2003 [DIRS 163274] Section 2.2.1.3.10)
- Airborne transport of radionuclides (NRC 2003 [DIRS 163274] Section 2.2.1.3.11)
- Redistribution of radionuclides in soil (NRC 2003 [DIRS 163274] Section 2.2.1.3.13).

This report addresses the integrated subissues of mechanical disruption of engineered barriers (NRC 2003 [DIRS 163274], Section 2.2.1.3.2), volcanic disruption of waste packages (NRC 2003 [DIRS 163274], Section 2.2.1.3.10), and airborne transport of radionuclides (NRC 2003 [DIRS 163274], Section 2.2.1.3.11), in terms of providing TSPA with distributions of the number of waste packages damaged for the igneous intrusion modeling case and for the volcanic eruption modeling case.

E.3 YMRP ACCEPTANCE CRITERIA

Yucca Mountain Review Plan, Final Report (YMRP) (NRC 2003 [DIRS 163274]) associates the integrated subissue of volcanic disruption of waste packages with the requirements listed in 10 CFR 63.114 (10 CFR 63(a)-(c) and (e)-(g) [DIRS 180319]). Section 2.2.1.3.10.3 of the YMRP (NRC 2003 [DIRS 163274]) describes the acceptance criteria that the NRC will use to evaluate the adequacy of information addressing the volcanic disruption of waste packages in the license application.

The outputs of this analysis are used to describe the source term for TSPA analyses related to the igneous activity volcanic eruption modeling case and the igneous intrusion modeling case. The analyses do not address the amount of damage to waste packages or contents. Rather, for the intrusion case, if intersection of the repository occurs, all drifts are inundated by magma, and all waste packages are assumed to be damaged (Section 5.1 of this report). For the eruption modeling case, the number of waste packages intersected by eruptive conduits is estimated. Hence, the cumulative frequency distribution for the intrusion modeling case represents a step function with values of zero for realizations in which intersection of the repository does not occur, or 11,629 for realizations in which intersection occurs (Section 7.2 of this report)

E.4 YUCCA MOUNTAIN REVIEW PLAN CRITERIA ASSESSMENT

The NRC has identified two integrated subissues that are addressed by information in this report: mechanical disruption of engineered barriers (Section E.4.1) and volcanic disruption of waste packages (Section E.4.2).

Yucca Mountain Review Plan, Final Report (NRC 2003 [DIRS 163274]) provides the review methods and acceptance criteria that the NRC staff will use to evaluate the technical adequacy of the license application. The applicable acceptance criteria, which may also be addressed in other analysis and model reports, are fully addressed when this report is considered in conjunction with those reports. Although not clearly described in the YMRP, *Integrated Issue Resolution Status Report* (NRC 2002 [DIRS 159538], Section 3.3.10.1, Paragraph 1) specifically notes that "Interactions between basaltic magma and waste packages not located along a subvolcanic conduit to the surface are evaluated in the Mechanical Disruption of Engineered Barriers Integrated Subissue" (Section 2.2.1.3.2).

E.4.1 Integrated Subissue: Mechanical Disruption of Engineered Barriers

The following description identifies information from this report that addresses YMRP acceptance criteria and/or review methods related to the integrated subissue of mechanical disruption of engineered barriers (NRC 2003 [DIRS 163274], Section 2.2.1.3.2.3).

Acceptance Criterion 1: System Description and Model Integration Are Adequate

The objectives for calculating the number of waste package hit are described in Section 6.1 of this report. The purpose of the analysis and integration of the analysis into TSPA are described in Section 1. The acceptance criteria addressed in this section apply to the igneous intrusion modeling case.

- (1) *Total system performance assessment adequately incorporates important design features, physical phenomena, and couplings, and uses consistent and appropriate assumptions throughout the mechanical disruption of engineered barrier abstraction process.*

This analysis provides TSPA with distributions for the number of waste packages damaged by contact with magma. For the intrusion modeling case, the distribution represents a step function with values of zero (0), for realizations with no intersection of the repository, or 11,629 for realizations in which intersection occurs.

The primary geologic and geometric elements used in the analysis (the basalt dike(s) and any conduits, and the repository layout) are identified and summarized in Sections 6.3.1 through 6.3.4. Assumptions about the treatment of waste packages following intersection of the repository are described in Section 5.1. The number of waste packages damaged by an igneous intrusion are described in Section 7.2 and summarized in Figure 7-1. Results of the analysis are summarized in Table 7-1, and conclusions are presented in Section 7.2. The principal outputs of the analysis are CDFs for the number of waste packages hit by an igneous intrusion and by an eruptive center probability. The DTN outputs are referenced in Table 7-1.

It is important to note that this analysis provides only the number of waste packages damaged by igneous intrusion into the repository or by development of one or more eruptive conduits through the repository. The analysis does not address the nature and extent of damage to waste packages; that assessment is provided in *Dike/Drift Interactions* (SNL 2007 [DIRS 177430], Section 6.4.3.8).

- (2) *The description of geological and engineering aspects of design features, physical phenomena, and couplings that may affect mechanical disruption of engineered barriers is adequate.*

The primary geologic and geometric elements used in the analysis (the volcanic dike(s) and the repository layout) are identified and summarized in Sections 6.3.1 through 6.3.4. Assumptions about the treatment of waste packages in drifts intersected by a dike are described in Section 5.1.

This analysis provides the number of waste packages damaged by igneous intrusion into the repository. The analysis does not address the nature and extent of damage to waste packages or environmental conditions that might affect the extent of damage. The assessment of waste package damage and identification of environmental parameters used in the damage analysis are provided in *Dike/Drift Interactions* (SNL 2007 [DIRS 177430], Section 6.4.3.8).

- (3) *The abstraction of mechanical disruption of engineered barriers uses assumptions, technical bases, data, and models that are appropriate and consistent with other related U.S. Department of Energy abstractions. The descriptions and technical bases provide transparent and traceable support for the abstraction of mechanical disruption of engineered barriers.*

Data and parameters used in this analysis are traced to related documents listed in Table 4-1. Assumptions used in the analysis are described in Section 5. Assumptions about the treatment of waste packages in drifts intersected by a dike and in drifts not intersected by a dike are described in Section 5.1. Section 6.3.2 describes the analysis of the number of waste packages hit by igneous intrusion and by conduits associated with a volcanic eruption through the repository.

- (4) *Boundary and initial conditions used in the total system performance assessment abstraction of mechanical disruption of engineered barriers are propagated throughout the abstraction approaches.*

Geologic and geometric variables affect the consideration of the number of waste packages that could be affected by igneous intrusion into the repository or volcanic eruption through the repository. As described in Section 6.3.2, the geologic variables are mostly stochastic parameters that include dike length and orientation and geometric elements that include locations of geologic features and repository design elements. Methods to propagate the geologic and geometric variables through the analysis of the number of waste packages hit by igneous intrusion are described in Sections 6.3.1 and 6.3.2 and 6.3.3.

- (5) *Sufficient data and technical bases to assess the degree to which features, events, and processes have been included in this abstraction are provided.*

Features, events, and processes (FEPs) that are specifically addressed by information in this report are identified in Section 6.2 and Table 6-1. Table 6-1 also identifies sections of the report in which the FEPs are addressed. Nine FEPs are associated with igneous activity, but, because of the assumption that intersection of the repository results in damage to all waste packages, only two of the nine is relevant to the analysis of mechanical disruption of engineered barriers by igneous activity and have been included in TSPA, as follows:

- FEP 1.2.04.03.0A, Igneous intrusion into repository. The technical basis for inclusion is provided in Section 6.2.2.2 of *LA FEP List and Screening* (SNL 2007 [DIRS 181613]).

- FEP 1.2.04.04.0A, Igneous intrusion interacts with EBS components. The technical basis for inclusion is provided in Section 6.2.2.3 of *LA FEP List and Screening (SNL 2007 [DIRS 181613])*.

The integration of the included FEPs into the modeling and analysis of mechanical disruption of engineered barriers by igneous activity is described in *Dike/Drift Interactions (SNL 2007 [DIRS 177430], Section 6.1)*. In *Dike/Drift Interactions (SNL 2007 [DIRS 177430], Sections 6.2 and 6.3)*, the process of igneous intrusion into the repository is described as dike propagation and includes the effects of natural and thermal stresses. The interactions of an intrusion with the engineered barrier system components is described in terms of the environment that develops in the repository following intrusion (SNL 2007 [DIRS 177430], Section 6.4).

The output of the analyses described in this report is a CDF for the number of waste packages hit by an igneous intrusion into the repository (Figure 7-1).

Acceptance Criterion 2: Data Are Sufficient for Model Justification

- (1) *Geological and engineering values, used in the license application to evaluate mechanical disruption of engineered barriers, are adequately justified. Adequate descriptions of how the data were used and appropriately synthesized into the parameters are provided.*

Geologic and geometric variables affect the consideration of the number of waste packages that could be affected by igneous intrusion into the repository or volcanic eruption through the repository. Input data are justified in Section 4.1, and their synthesis into parameters is described in Section 6.3. As described in Section 6.3.2, the geologic variables are mostly stochastic parameters that include dike length and orientation and geometric elements that include locations of geologic features and repository design elements. Methods to propagate the geologic and geometric variables through the analysis of the number of waste packages hit by igneous intrusion are described in Sections 6.3.2 and 6.3.3. For the intrusion modeling case, the output of the analysis is a CDF for the number of waste packages damaged by an igneous intrusion into the repository (Figure 7-1).

- (2) *Sufficient data have been collected on the geology of the natural system, engineering materials, and initial manufacturing defects to establish initial and boundary conditions for the total system performance abstraction of mechanical disruption of engineered barriers.*

The analysis described in this report uses a set of data about igneous activity parameters (e.g., the probability of a dike intersecting the repository, dike lengths, dike orientations, and the number of volcanic conduits that could form within the repository footprint) derived from studies of igneous activity in the Yucca Mountain region (SNL 2007 [DIRS 174260]). Data and input parameters used in this analysis are described in Section 4.1 and summarized in Table 4-1. Table 4-1 also provides

specific references to individual sources for data used in the analysis. Assumptions used in the analysis and derived from the data inputs are described in Section 5.1.

- (3) *Data on geology of the natural system, engineering materials, and initial manufacturing defects, used in the total system performance assessment abstraction, are based on appropriate techniques. These techniques may include laboratory experiments, site-specific field measurements, natural analogue research, and process-level modeling studies. As appropriate, sensitivity or uncertainty analyses used to support the U.S. Department of Energy total system performance assessment abstraction are adequate to determine the possible need for additional data.*

The analysis described in this report uses a set of data about igneous activity parameters (e.g., the probability of a dike intersecting the repository, dike lengths, dike orientations, and the number of volcanic conduits that could form within the repository footprint) derived from studies of igneous activity in the Yucca Mountain region (SNL 2007 [DIRS 174260]). Data and input parameters used in this analysis are described in Section 4.1 and summarized in Table 4-1. Table 4-1 also provides specific references to individual sources for data used in the analysis. Assumptions used in the analysis and derived from the data inputs are described in Section 5.1.

Acceptance Criterion 3: Data Uncertainty Is Characterized and Propagated Through the Model Abstraction

Data and parameters used for the analysis of magma-waste package and magma-waste form interactions are described in Section 4.1.

- (1) *Models use parameter values, assumed ranges, probability distributions, and bounding assumptions that are technically defensible, reasonably account for uncertainties, and variabilities, and do not result in an under-representation of risk.*

The analysis described in this report uses a set of data about igneous activity parameters (e.g., the probability of a dike intersecting the repository, dike lengths, dike orientations, and the number of volcanic conduits that could form within the repository footprint) derived from studies of igneous activity in the Yucca Mountain region (SNL 2007 [DIRS 174260]). Data and input parameters used in this analysis are described in Section 4.1 and summarized in Table 4-1. Table 4-1 also provides specific references to individual sources for data used in the analysis. Assumptions used in the analysis and derived from the data inputs are described in Section 5.1.

The representation of risk is a TSPA responsibility. This report describes no results that could be used to evaluate the representation of risk from magma-drift and magma-waste package interactions.

- (2) *Process-level models used to represent mechanically disruptive events within the emplacement drifts at the proposed Yucca Mountain repository are adequate. Parameter values are adequately constrained by Yucca Mountain site data, such that the estimates of mechanically disruptive events on engineered barrier integrity are not*

underestimated. Parameters within conceptual models for mechanically disruptive events are consistent with the range of characteristics observed at Yucca Mountain.

The analysis described in this report examines the number of waste packages that could be damaged by intersection of the repository by a basaltic volcanic dike (Figure 7-1). Sources of inputs for the analysis are listed in Table 4-1. Consistency of parameter values with observed ranges of characteristics (e.g., frequency of intersection of the repository by a basalt dike, dike length and orientation, and the CDF for number of conduits that could form within the repository) are described in *Characterize Eruptive Processes at Yucca Mountain, Nevada* (SNL 2007 [DIRS 174260]). Table 7-1 presents a mapping of CDF technical product outputs from this report to the results spreadsheet. This analysis does not evaluate failure modes for engineered barrier components or damage that could result from exposure of waste packages and waste forms to magmatic conditions. Assessments of damage to waste packages and waste forms associated with intrusion of a dike into the repository or eruption of a volcano through the repository are provided in *Dike/Drift Interactions* (SNL 2007 [DIRS 177430], Section 6.4.3.8).

- (3) *Uncertainty is adequately represented in parameter development for conceptual models, process-level models, and alternative conceptual models considered in developing the assessment abstraction of mechanical disruption of engineered barriers. This may be done either through sensitivity analyses, or use of conservative limits.*

Uncertainties in the current analysis have been intrinsically accounted for by the nature of the Latin Hypercube Sampling approach (Section 3). Conservatism adopted in the analyses ensures that the risk is not under-represented; uncertainties are discussed in Section 6.4.

- (4) *Where sufficient data do not exist, the definition of parameter values and conceptual models is based on appropriate use of expert elicitation, conducted in accordance with NUREG-1563 (Kotra et al. 1996 [DIRS 100909]). If other approaches are used, the U.S. Department of Energy adequately justifies their use.*

Expert elicitation was not used in the development of the analysis of number of waste packages hit by igneous intrusion into the repository. However, expert elicitation was used to estimate the annual frequency of intersection of the repository by an igneous event (CRWMS M&O 1996 [DIRS 100116], Section 4.2) and summarized in *Characterize Framework for Igneous Activity at Yucca Mountain, Nevada* (BSC 2004 [DIRS 169989], Section 6.3).

Acceptance Criterion 4: Model Uncertainty Is Characterized and Propagated Through the Model Abstraction

- (1) *Alternative modeling approaches of features, events, and processes are considered and are consistent with available data and current scientific understanding, and the results and limitations are appropriately considered in the abstraction.*

Features, events, and processes that are included in this report are described in Section 6.2 and summarized in Table 6-1. Table 6-1 also summarizes the TSPA description of each included FEP and includes references to sections of the report in which the TSPA disposition is described.

- (2) *Consideration of conceptual model uncertainty is consistent with available site characterization data, laboratory experiments, field measurements, natural analogue information and process-level modeling studies; and the treatment of conceptual model uncertainty does not result in an under-representation of the risk estimate.*

Uncertainties in the current analysis have been intrinsically accounted for by the nature of the Latin Hypercube Sampling approach with use of conditional probability distributions for key inputs as described in Section 4.1. Additionally, conservative assumptions have been included to bound uncertainties associated with parameters used in the analysis as described in Sections 5 and 6.3.3 (also see Acceptance Criterion 3, Item 4). This report describes the number of waste packages hit by igneous intrusion into the repository (Figure 7-1). The representation of risk is a TSPA responsibility. No results that could be used to evaluate the representation of risk from the abstractions for number of waste packages are developed in this report.

Acceptance Criterion 5: Model Abstraction Output Is Supported by Objective Comparisons

- (1) *Models implemented in this total system performance assessment abstraction provide results consistent with output from detailed process-level models and/or empirical observations (laboratory and field testing and/or natural analogues).*

The bases for the analysis of number of waste packages damaged by igneous intrusion into the repository are presented in Section 6.3.2. The abstraction of the number of waste packages damaged by an intrusion into the repository is presented in Section 6.3.3 and summarized in Figure 7-1.

- (2) *Outputs of mechanical disruption of engineered barrier abstractions reasonably produce or bound the results of corresponding process-level models, empirical observations, or both.*

The output of this analysis is a distribution for the number of waste packages hit by igneous intrusion (Figure 7-1). The output represents a step function with values of zero for realizations in which the repository is not intersected and 11,629 for realizations in which intersection occurs.

E.4.2 Integrated Subissue: Volcanic Disruption of Waste Packages

The following information addresses the YMRP acceptance criteria related to volcanic disruption of waste packages (NRC 2003 [DIRS 163274], Section 2.2.1.3.10.3).

Acceptance Criterion 1: System Description and Model Integration Are Adequate

- (1) *Total system performance assessment adequately incorporates important design features, physical phenomena, and couplings, and uses consistent and appropriate assumptions throughout the volcanic disruption of waste package abstraction process.*

The intersection of one or more repository drifts by a basaltic dike and subsequent damage to waste packages by inclusion in a volcanic conduit are coupled processes, whose characteristics depend on the nature of the processes that are associated with the intersection and subsequent evolution of the magma/drift system. This report describes the number of waste packages intersected by conduits that could form within the repository. Results of the analysis are presented in Sections 6.3.2. The methods used to propagate uncertainties in the number and diameters of conduits are described in Section 6.3.2 and 6.3.3. Assumptions supporting the analysis are described in Section 5.2. The uses of information from this analysis, in terms of FEP issues, are summarized in Table 6-1.

This analysis incorporates design features as documented in Table 4-1 and reflects the analyses and models used as input and with companion analysis reports and model reports, including *Characterize Framework for Igneous Activity at Yucca Mountain, Nevada* (BSC 2004 [DIRS 169989], Table 7-1), *Characterize Eruptive Processes at Yucca Mountain, Nevada* (SNL 2007 [DIRS 174260], especially Section 6.3.3), and *Dike/Drift Interactions* (SNL 2007 [DIRS 177430], Sections 6.3 and 6.4). This analysis also provides the source term for the volcanic eruption modeling case as described in *Atmospheric Dispersal and Deposition of Tephra from a Potential Volcanic Eruption at Yucca Mountain, Nevada* (SNL 2007 [DIRS 177431]).

- (2) *Models used to assess volcanic disruption of waste packages are consistent with physical processes generally interpreted from igneous features in the Yucca Mountain region and/or observed in active igneous systems.*

No models were used in the analysis documented in this report. However, the analyses used to develop parameters for TSPA are related to this criterion. The analyses documented in this report are limited to estimating the number of waste packages included in eruptive conduits for the volcanic eruption modeling case. These analyses do not examine waste package damage caused by, or damage processes related to, volcanic disruption of the repository. Models that assess damage to waste packages and waste forms are documented in *Dike/Drift Interactions* (SNL 2007 [DIRS 177430], Section 6.4.3.8). Other pertinent physical processes are described in *Characterize Eruptive Processes at Yucca Mountain, Nevada* (SNL 2007 [DIRS 174260]), and the processes are investigated in *Dike/Drift Interactions* (SNL 2007 [DIRS 177430], Sections 6.3 and 6.4).

- (3) *Models account for changes in igneous processes that may occur from interactions with engineered repository systems.*

The report does not consider changes in igneous processes that could result from interactions with engineered repository systems. Models of the interactions between a basalt dike(s) and the engineered repository system are documented in *Dike/Drift Interactions* (SNL 2007 [DIRS 177430], Sections 6.3 and 6.4). Results of these models support this analysis.

Acceptance Criterion 2: Data Are Sufficient For Model Justification

- (1) *Parameter values used in the license application to evaluate volcanic disruption of waste packages are sufficient and adequately justified. Adequate descriptions of how the data were used, interpreted, and appropriately synthesized into the parameters are provided.*

This analysis derives parameters that are sampled as direct feeds to the TSPA (Section 6.3.2). Design features and developed parameters based on analogue data are identified in Table 4-1. Data used in the analysis are described and justified and the bases for the values are documented in the references cited in this report (Sections 4.1 and 6.3).

- (2) *Data used to model processes affecting volcanic disruption of waste packages are derived from appropriate techniques. These techniques may include site-specific field measurements, natural analogue investigations, and laboratory experiments.*

The analysis of the number of waste packages hit does not include any modeling of processes affecting volcanic disruption of waste packages. Upstream analyses provide inputs for this analysis, and the bases for the values used in this analysis are documented in the references cited in this report (Sections 4.1 and 6.3).

- (3) *Sufficient data are available to integrate features, events, and processes, relevant to volcanic disruption of waste packages into process-level models, including determination of appropriate interrelationships and parameter correlations.*

Features, events, and processes related to this analysis and included in TSPA are identified in Table 6-1 and Section 6.2. Screening of igneous activity FEPs and the technical basis for including (or excluding) each FEP in (from) TSPA are described in *LA FEP List and Screening* (SNL 2007 [DIRS 181613]).

Acceptance Criterion 3: Data Uncertainty Is Characterized and Propagated Through the Model Abstraction

- (1) *Models use parameter values, assumed ranges, probability distributions, and bounding assumptions that are technically defensible, and reasonably account for uncertainties and variabilities, and do not result in an under-representation of the risk estimate.*

The data, parameter values, assumed ranges, and probability distributions that are used as inputs for this analysis are identified in Section 4.1 and Table 4-1. Justifications for the use of the various forms of input information are provided in Sections 6.3.2. The bases for the values are documented in the references cited in this report.

- (2) *Parameter uncertainty accounts quantitatively for the uncertainty in parameter values observed in site data and the available literature (i.e., data precision), and the uncertainty in abstracting parameter values to process-level models (i.e., data accuracy).*

Methods to include uncertainties in the various input parameters needed for this analysis are described in Sections 6.3.2, 6.3.4, and 6.4. The technical bases for the input values are provided in the documents that have been cited in this report. Outputs of the analysis are described in terms of CDFs (Figures 7-1 and 7-2) and/or conditional probabilities that capture the uncertainties associated with the parameters (Section 6.4).

Acceptance Criterion 4: Model Uncertainty Is Characterized and Propagated Through the Model Abstraction

Parameter distributions developed in this analysis are utilized in TSPA to propagate epistemic uncertainty related to input parameter distributions (Sections 6.3.2 and 6.4). Disruptive event models used to analyze interactions between a basalt dike(s) and engineered repository systems are documented in *Dike/Drift Interactions* (SNL 2007 [DIRS 177430], Sections 6.2, 6.3, and 6.4).

Acceptance Criterion 5: Model Abstraction Output Is Supported by Objective Comparisons

The analysis documented in this report provides the number of waste packages that could be included in volcanic conduits (Section 6.4 and Figure 7-2). Models used to analyze interactions between a basalt dike(s) and engineered repository systems are documented in *Dike/Drift Interactions* (SNL 2007 [DIRS 177430], Sections 6.2, 6.3, and 6.4).

E.6 NUREG-1804, REV 2, SECTION 2.2.1.3.11.3: AIRBORNE TRANSPORT OF RADIONUCLIDES

Acceptance Criterion 2: Data Are Sufficient for Model Justification

- (3) *Sufficient data are available to integrate features, events, and processes, relevant to airborne transport of radionuclides into process-level models. Including determination of appropriate interrelationships and parameter correlations.*

The direct inputs to the analysis are described in Section 4.1 of this report, and the features, events, and processes that are included in the analysis are documented in Section 6.2. Nine FEPs are associated with igneous activity, and one of those nine is relevant to the analysis of volcanic disruption of waste packages and has been included in TSPA, as follows:

- 1.2.04.06.0A, Eruptive conduit to surface intersects repository. The technical basis for inclusion is provided in Section 6.2.2.6 of *LA FEP List and Screening (SNL 2007 [DIRS 181613])*.

The integration of the included FEP into the modeling and analysis of volcanic disruption of waste packages is described in Section 6.2 and Section 6.3.2 of this report. The probability that at least one eruptive conduit would form within the repository footprint is presented as the ratio of the number of valid eruptive cases to the number of valid intrusive cases. Details of this calculation are provided in Appendices A and B. The ratio is equal to 0.28 (Section 7.2 and Table 7-1 of this report).

**APPENDIX F
GLOSSARY**

APPENDIX F GLOSSARY

conduit—The vertical or subvertical, essentially cylindrical, tube that brings magmatic material to land surface. Conduit is the appropriate term regarding the subsurface, and PA conceptual models emphasize the interactions that occur at the intersection of a conduit with the repository.

dike—A tabular subplanar magma-filled crack that cuts across local geologic contacts, such as bedding planes. Length and width (or thickness) describe the size of a dike, although minor variations in width and strike direction can be expected along the length of any one dike.

dike system—One or more dikes closely related in space and time. Dike systems may include multiple dikes that share a common magmatic source with a single volcano. This definition does not preclude the possibility that a dike system may feed more than one volcano.

eruptive event (with respect to repository performance)—The formation of a volcano that includes at least one subsurface conduit.

igneous activity—Any process associated with the generation, movement, emplacement, or cooling of molten rock within the earth or on the earth's surface.

intrusive event (with respect to repository performance)—An igneous structure (such as a dike, dike system, or other magmatic body in the subsurface) that intersects the repository footprint at the repository elevation.

magma—Partially or completely molten rock within the earth's crust or mantle.

volcanic event—The formation of a volcano (with one or more vents) resulting from the ascent of basaltic magma through the crust as a dike or system of dikes.

volcano—A geologic feature that includes an edifice of magmatic material erupted on the land surface, one or more conduits that feed the eruption, and a dike or dike system that feeds the conduit or conduits.

INTENTIONALLY LEFT BLANK

APPENDIX G
CRITICAL DISTANCE ANALYSIS

APPENDIX G CRITICAL DISTANCE ANALYSIS

G.1 INTRODUCTION

An analysis was performed to define the distance between an ascending dike and the emplacement drift at which the pillar between the dike and the drift fails, and magma from the dike can break through the pillar and flow into the drift. The methods and results of this analysis are reported in this appendix. Because no new mathematical model development was required and because the work was performed using straightforward engineering applications, this work is considered a scientific analysis.

As a dike propagates through rock, it causes damage, which occurs mostly in the "process zone" ahead of the dike tip. That damage is evident up to a certain depth into the dike walls behind the dike tip (Figure G-1). Based on field observations of shallow intrusions at Pahute Mesa, Nevada, and at Paiute Ridge, Nevada (BSC 2005 [DIRS 174070], Figures 6-7 and 6-5, respectively), it can be inferred that at depths less than or equivalent to the depth of the repository, the horizontal extent of rock disruption to the surrounding dike walls is much less than near the surface. For the purposes of this analysis, this process zone is not included.

Moreover, a rising dike may affect stability of the drift located in its vicinity (but not intersected by the dike) and of the "pillar" between the dike and the drift, due to variation in the horizontal stress induced by the dike. Far behind the dike tip and magma front, the horizontal stress normal to the dike plane is practically equal to the in situ horizontal stress. Therefore, an excavation that is relatively close to the dike but far below the magma front will be under stress conditions similar to those occurring were the dike not to exist. However, as the dike tip and the magma front pass by the excavation, the horizontal stress will undergo changes. First, the stress will decrease from the in situ value to zero at the stage when the gap ahead of magma front is at the elevation of the excavation—i.e., the dike tip is above the drift elevation and the magma front below the drift elevation. Subsequently, as the magma front rises above the elevation of the excavation, the magma pressure in the dike will cause an increase in the horizontal stress (ΔP in Figure G-1).

Two situations can be considered in this regard. The first case is the *nominal* situation, for which the increase in horizontal stress is less than 1 MPa in excess of the in situ horizontal stress (SNL 2007 [DIRS 177430], Section 6.3.7.1). The second case is an *extreme* situation (e.g., associated with the possibility of plugging the dike above the repository level), for which the increase in magma pressure can be even more in excess of the in situ horizontal stress, although not larger than the lithostatic vertical stress at the level of the repository (approximately 7 MPa). In summary, the limiting stress conditions (zero horizontal stress and maximum overpressure for the *nominal* and the *extreme* situations, respectively) will control the critical distance between the dike and the excavation when the pillar between the dike and the drift collapses and magma starts to flow into the excavation.

Stability of the pillar between the drift of radius R and a vertical boundary representing the dike located at a distance d from the drift wall was investigated with the two-dimensional continuum code FLAC V. 4.0. A simple Mohr-Coulomb constitutive relation was used to represent inelastic

deformation of the rock mass. Topopah Spring Tuff at the repository level is a fractured rock mass. The degree to which a continuum is an appropriate representation of the rock mass in the calculation of critical distance between the drift and the dike depends on the characteristic dimension of the analyzed problem compared to the average joint spacing. Jointing of the rock mass on the repository horizon is variable (i.e., orientation and spacing), but, in the poorest-quality rock mass, in which the critical distance between the dike and the drift will be the greatest, the average joint spacing is on the order of the fraction of a meter (between 0.1 m and 0.3 m, as reported in *Drift Degradation Analysis* (BSC 2004 [DIRS 166107], Section 6.4.1.1). For such a joint spacing, the continuum approximation of the deformation and stability of the pillar between the dike and the drift is adequate for pillar widths larger than 1 m, but uncertainty in predictions of the calculations increase as the pillar becomes narrower. Although this calculation shows that, for the best-quality rock mass, the critical distance can be very small, a fraction of a meter, the minimum critical distance was adopted to be equal to or larger than a half of the drift radius—i.e., 1.375 m.

Thermal effects on deformation and mechanical properties of the rock mass were not considered in the FLAC calculation. Test results in *Drift Degradation Analysis* (BSC 2004 [DIRS 166107], Table E-9) indicate that temperatures up to 200°C (which are higher than expected), due to radioactive heating in the first 1,000 years after closure, do not have a deleterious effect that would contribute to the degradation of mechanical properties of the drift wall. However, after completing the calculations, the critical distance is modified (see Section G.4) to account for the thermal effects of higher temperatures resulting from the intrusion of magma on the strength of the rock mass. Details of the analysis and results obtained are summarized in this appendix.

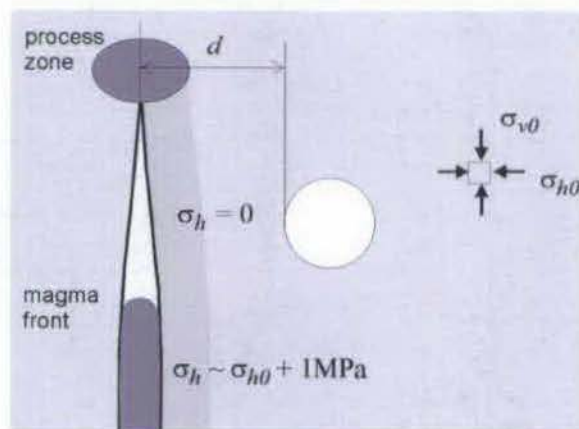

Figure G-1. Conditions of Dike Propagation in the Vicinity of the Drift

G.2 DESCRIPTION OF THE FLAC CALCULATION

In agreement with the mechanism of dike-drift interaction described in Section G.1, the following four stages are considered in the FLAC calculations. Figure G-2 shows intermediate FLAC results, which display the distributions of plastic (failure) zones under the conditions to be analyzed.

Stage 0 (Figure G-2a) represents the initial condition (before the drift and dike exist) of a rock mass at the repository level, subject to non-hydrostatic in situ stresses—the vertical stress equal to 7 MPa and the horizontal stress equal to 3.5 MPa (BSC 2004 [DIRS 166107], Section 6.3.1.1).

Stage 1 (Figure G-2b) represents the situation after excavation of the drift of radius R . As a result of excavation, stress redistribution occurs, and a plastic (or failure) zone of elliptical shape, with its major axis oriented perpendicular to the larger in situ stress, is observed (Figure G-2b).

Stage 2, also referred to as the “unpressurized dike stage” (Figure G-2c), considers the situation in which a vertical dike approaches the repository level from below. The vertical boundary at distance d from the wall of the drift represents the stress-free walls of the forming “crack” ahead of the advancing magma (Figure G-1). The calculation considers the most conservative situation for which the length of the stress-free crack is large enough that its mechanical effect on the drift is as if a stress-free vertical boundary exists in the vicinity of the drift. Because of the existence of the stress-free vertical boundary, further stress redistribution around the drift occurs, and a plastic zone showing a “butterfly” shape develops (Figure G-2c). The objective of the present analysis is to assess whether the zone between the drift and the vertical boundary is stable at this stage and represents a barrier to magma flow.

Stage 3, also referred to as the “pressurized dike stage” (Figure G-2d), considers the situation in which the dike has passed the repository level and magma is filling the crack considered in Stage 2. According to the discussion in Section 1, the vertical boundary is considered to be subject to a normal pressure equal to 5 MPa in the *nominal* case and to a normal pressure equal to 8 MPa in the *extreme* case. (Considering uncertainties in the calculation, both the nominal and extreme case pressures are increased by approximately 1 MPa as a safety margin.) Again, the objective of the present analysis is to assess whether the zone between the drift and the vertical boundary is stable at this stage and represents a barrier to magma flow.

Stages 0, 1, 2 and 3 have been analyzed for different distances d between the vertical boundary and the wall of the drift. The cases analyzed are for ratios $d/2R$ equal to 2.0, 1.0, 0.5, 0.25, 0.10 and 0.05, where $R = 2.75$ m is the radius of the drift.

The characteristics of the FLAC mesh used in the analysis are shown in Figure G-3a. The size of the mesh and the number of elements in both the horizontal and vertical directions are indicated in the figure. Note that Figure G-3a represents the full mesh considered in Stages 0 and 1 of the calculation sequence. For Stages 2 and 3, the portion of the mesh located on the left side of the vertical boundary representing the dike is removed. Figure G-3b shows an enlargement of the mesh in the vicinity of the drift used for the particular case $d/2R = 0.25$. For all considered values of $d/2R$, the characteristic size of zones in the vicinity of the drift is such that one diameter of drift comprises approximately 32 zones (i.e., zones have a side length of approximately 0.17 m).

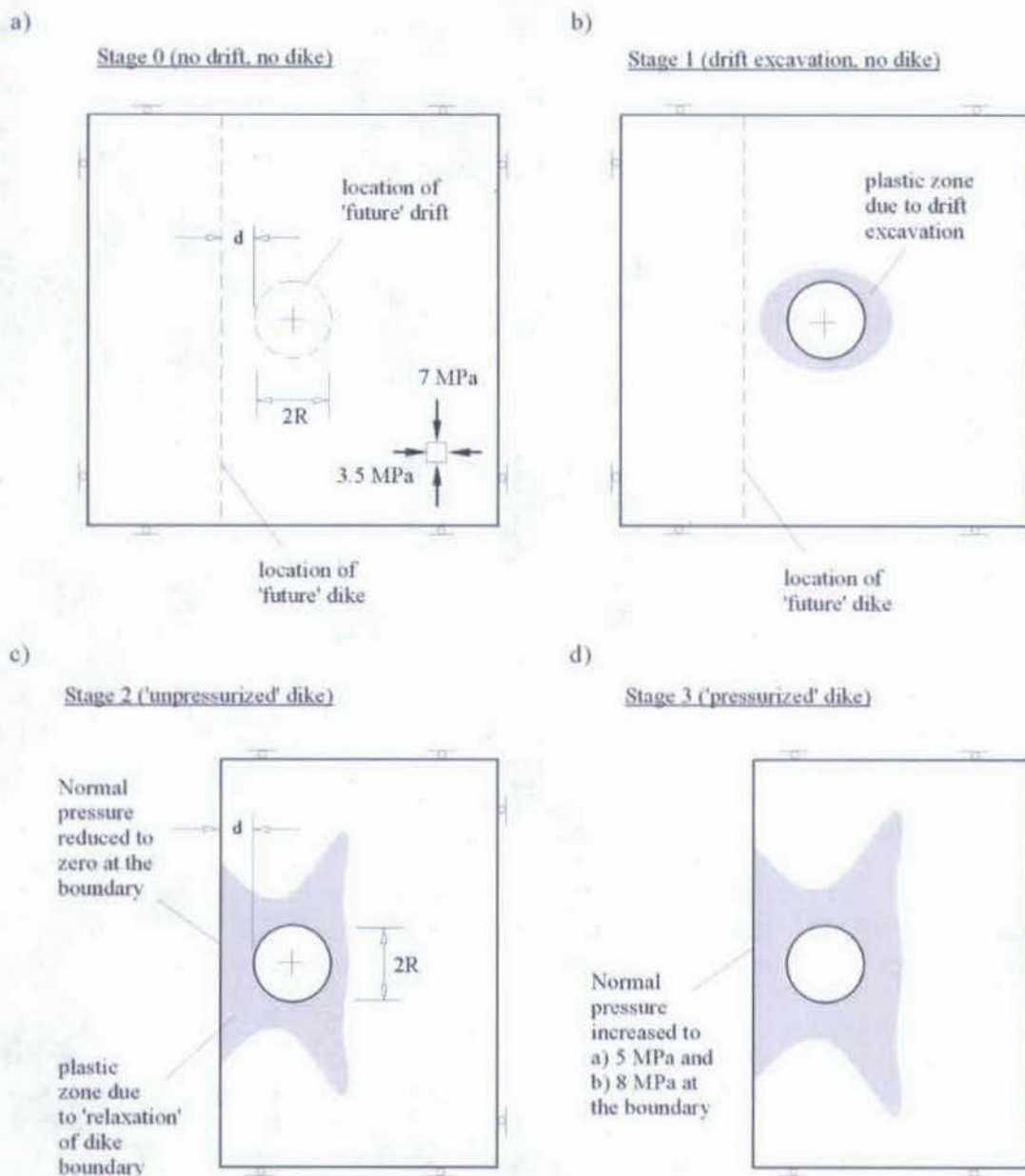

Figure G-2. Stages 0, 1, 2, and 3 Considered in the Calculation of Mechanical Interaction between Dike and Drift

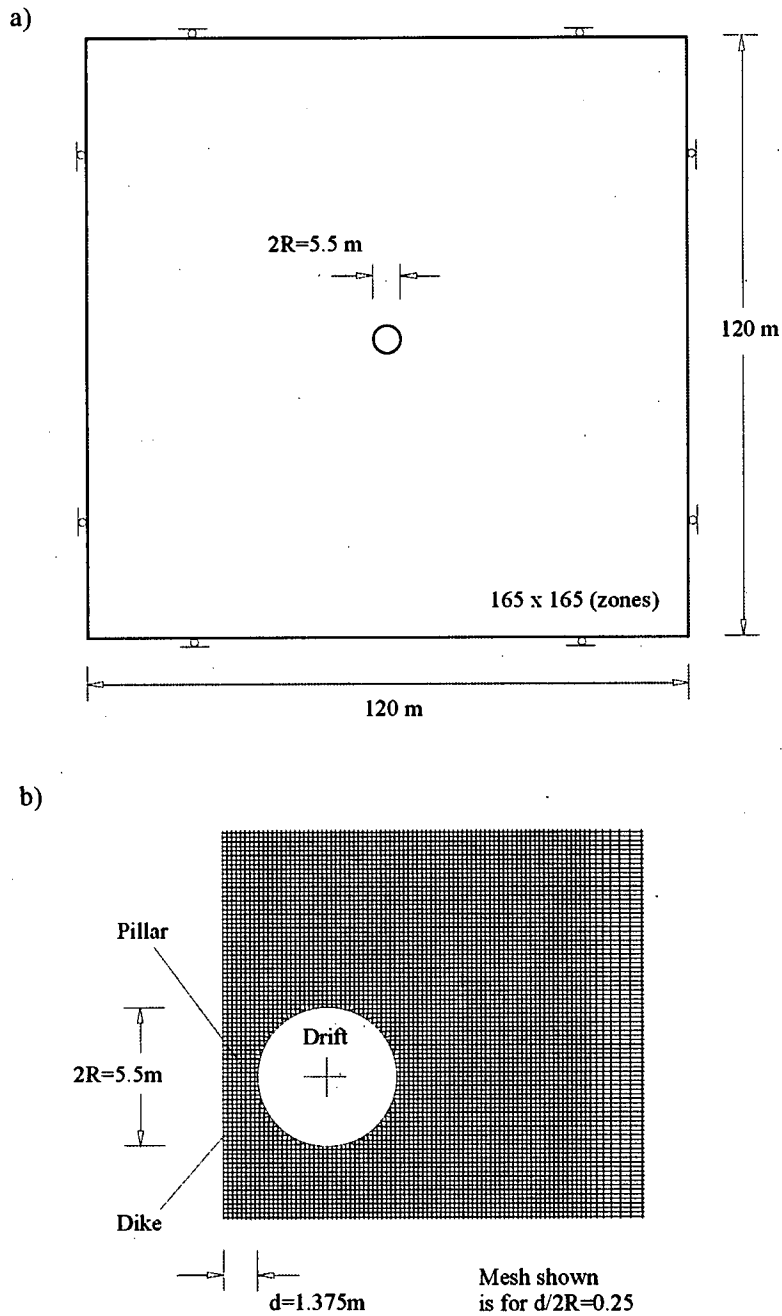
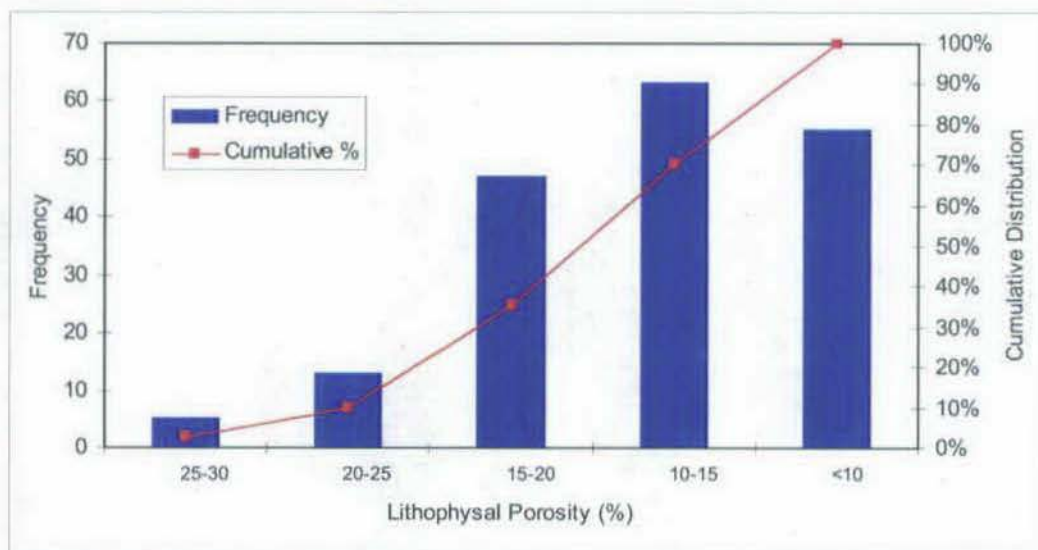

Figure G-3. Characteristics of the FLAC Mesh Used in the Analysis

The emplacement drifts will be located in two different types of rock mass units: (a) lithophysal, and (b) nonlithophysal. Because approximately 85% of the repository will be in the lithophysal rock mass and the lithophysal rock mass is generally weaker than the nonlithophysal (SNL 2007 [DIRS 178693], Section 6.4.2.1), only the lithophysal rock mass was considered in this analysis.

Variability of rock mass quality and mechanical properties of the lithophysal rock mass is represented by five rock-mass categories. Category 1 represents the poorest-quality rock mass; Category 5 represents the best-quality rock mass. Although many different factors affect rock-mass quality (e.g., lithological composition and fracturing), the lithophysal porosity has the most profound effect on mechanical properties (i.e., stiffness and strength) of the lithophysal units at the repository level. Different rock-mass categories of the lithophysal rock mass can be related directly to the lithophysal porosity. Based on mapping of lithophysal porosity in the Enhanced Characterization of the Repository Block (ECRB) Cross-Drift, the poor-quality categories (i.e., 1 and 2) include approximately 10 percent of the overall volume of lithophysal units (the histogram of mapped porosity frequency is shown in Figure G-4). The porosity ranges from the chart correspond to lithophysal rock-mass categories 1 through 5. Category 1 is for the largest lithophysal porosity; Category 5 is for the smallest lithophysal porosity. Categories 3 and 4 represent about 60% of the rock mass. The remaining 30% of the lithophysal rock mass falls into the best quality, Category 5.



Source: BSC 2004 [DIRS 166107], Figure E-10.

NOTE: Lithophysal porosity data are from ECRB Cross-Drift stations 14+44 to 23+26 (see DTN: MO0408MWDDDMIO.002\Calculation Files\Material property\Lith porosity\Drift Deg AMR AF T-A-P Fit V1.xls, worksheet: 'Volume Percent - Stats', cells L20 to L206 [DIRS 171483]).

Figure G-4. Distribution of Lithophysal Porosity Abundance (Frequency) for the Tptpl in the ECRB Cross-Drift

The mechanical properties used in the calculations correspond to the poorest rock-mass quality (Category 1), intermediate rock-mass quality (Category 3), and the best rock-mass quality (Category 5). The results obtained for Category 1 were conservatively assumed to be representative of Categories 1 and 2; the results obtained for Category 3 were conservatively assumed to be representative of Categories 3 and 4, making that case appropriate for 60% of the lithophysal mass in the repository. The properties of these three rock-mass categories, as listed in *Drift Degradation Analysis* (BSC 2004 [DIRS 166107], Table E-10) and sourced as

DTN: MO0408MWDDDMIO.002 [DIRS 171483] \calculation files\Material Property, file: *Rock Mass Strength v2.xls*, folder: Lithophysal Rock are summarized in Table G-1.

Table G-1. Mechanical Properties for Rock Mass Categories

Property	Category 1	Category 3	Category 5
Cohesion (MPa) ¹	2.07	4.14	6.21
Friction angle (degrees) ¹	45	45	45
Dilation angle (degrees) ²	0	0	0
Bulk Modulus (GPa) ¹	1.07	6.01	10.95
Shear Modulus (GPa) ¹	0.8	4.51	8.21

1. Source: DTN: MO0408MWDDDMIO.002\calculation files\Material Property, file: *Rock Mass Strength v2.xls*, folder: Lithophysal Rock [DIRS 171483].

2. Source: Assumption 5.5 of this report.

Spatial variability of the porosity of the lithophysal rock mass occurs on a length scale on the order of few meters. However, it is assumed in the calculations that a given rock-mass category extends throughout the entire analyzed domain. This assumption is certainly conservative for Category 1, which is quite sparse on the repository level.

Elasto-plastic Mohr-Coulomb material constitutive relation is used in the FLAC simulations. The simulations considered both an elastic/perfectly plastic behavior and an elastic/perfectly brittle behavior. The stress-strain post-peak behavior has an important effect on the stability of the rock mass. Unfortunately, the post-peak portion of the stress-strain curve is very difficult to determine for brittle materials such as rocks. Another difficulty with understanding the post-peak behavior of the rocks is that it is scale dependent. The existing laboratory and in situ test results on Topopah Spring Tuff do not provide sufficient evidence of their post-peak behavior. Hard rocks (relatively unfractured) generally exhibit brittle response as a result of fracturing when peak strength is reached. The perfectly brittle constitutive relation approximates such a mechanical behavior within the context of continuum mechanics. The poor-quality rock mass (e.g., lithophysal Category 1) usually is intensely fractured as a result of previous mechanical damage. Subsequent loading beyond the strain corresponding to the peak strength most likely will exhibit perfectly plastic post-peak behavior (the strength remains the same despite the additional plastic strain), because its original peak strength already is reduced to the residual strength. Although both approximations were used in calculations for all categories considered, the results obtained with perfectly plastic relation were used to determine the critical distance for Categories 1 and 2, while the results obtained with the perfectly brittle relation were used to determine the critical distance for the other categories. This approach is certainly a conservative representation of post-peak behavior for better quality lithophysal rock mass (i.e., Categories 3, 4 and 5), because perfectly brittle response means sudden loss of strength as soon as the peak strength of the rock mass is reached. Perfectly plastic constitutive relation is a reasonable representation of post-peak behavior of Categories 1 and 2 lithophysal rock mass, which have peak strength already degraded.

G.3 RESULTS OF FLAC CALCULATIONS

Stability of the pillar between the drift and the boundary representing the dike was analyzed for different stages of dike propagation relative to the drift and different distances between the dike and the drift (described earlier; see Figures G-1 and G-3b). The criterion used to determine whether the pillar was "stable" or "unstable" was based on whether the calculation was able to reach equilibrium for the given stress conditions in each of the stages represented in Figure G-2. If the pillar is unstable for a given set of loading conditions, the pillar deformation continuously progresses during the simulation, never reaching the equilibrium configuration. The histories of displacements and velocities for points along a horizontal line intersecting the pillar were recorded and analyzed to assess the stability conditions of the pillar. For some of the analyzed cases, the pillar remains stable for all loading stages, although, in the process, a significant portion of the simulated domain, including the entire cross-section of the pillar, has undergone plastic deformation. The equilibrium is achieved in those cases even if the material is softening, because the load is transferred from the yielding pillar to other portions of the rock mass still deforming elastically. Plastic deformation in a continuum representation of a rock mass indicates fracturing of the rock mass. If the pillar deforms plastically throughout the entire cross-section, it is questionable whether the pillar will be an effective barrier to percolation (movement) of the magma through the fractured rock mass between the dike and the drift, which eventually will lead to erosion and further weakening of the pillar. Therefore, the actual conditions for critical distance between the dike and the drift are that the pillar is stable and at least some certain portion of the pillar between the dike and the drift remain elastic (i.e., unbroken) for all loading steps.

Table G-2 summarizes the results found from the analysis for rock mass Category 1 and perfectly plastic behavior. (Category 1 was analyzed for both perfectly plastic and perfectly brittle post-peak behavior, but only results for the perfectly-plastic case are reported here, as they are more representative of Category 1 material behavior.) Figures G-5 through G-17 show views of the plastic extent obtained with FLAC for the different stages represented in Table G-2. Figure G-5 shows results (plastic extent) for Stage 1, which are common to all values of ratio $d/2R$ listed in Table G-2. Figures G-6, G-7, G-8, G-9, G-10, and G-11 show Stage 2 results for ratio $d/2R$ equal to 2, 1, 0.5, 0.25, 0.1, and 0.05, respectively. Figures G-12, G-13, G-14, G-15, G-16, and G-17 show the corresponding results for Stage 3 and for the two values of lateral pressure considered in the calculations (i.e., 5 MPa and 8 MPa).

Table G-2. Stability Conditions Obtained with FLAC for the Pillar between the Dike and the Drift for Rock Mass Category 1 and Perfectly Plastic Behavior

$d/2R$	d [m]	Stage 1	Stage 2	Stage 3 (5 MPa)	Stage 3 (8 MPa)
2.0	11	Stable	Stable	Stable	Stable
1.0	5.5		Stable	Stable	Stable
0.5	2.75		Stable, broken	Stable, broken	Stable, broken
0.25	1.375		Stable, broken	Stable, broken	Stable, broken
0.10	0.55		Stable, broken	Unstable	Unstable
0.05	0.275		Stable, broken	Unstable	Unstable

Output DTN: MO0506SPACRITL.000.

Inspection of results from Table G-2 and from Figures G-5 through G-17 suggests that for rock mass Category 1 and perfectly plastic behavior, the stability of the pillar between the drift and the dike is compromised only for pillars of small width (ratios $d/2R$ equal to 0.1 and 0.05) and only when pressure is considered for the lateral boundary (i.e., for Stage 3 in Figure G-2). However, as illustrated in Figures G-6 and G-7 (for Stage 2) and Figures G-12 and G-13 (for Stage 3), a portion of the pillar remains elastic only if $d/2R \geq 1$ (i.e., the critical distance is 5.5 m).

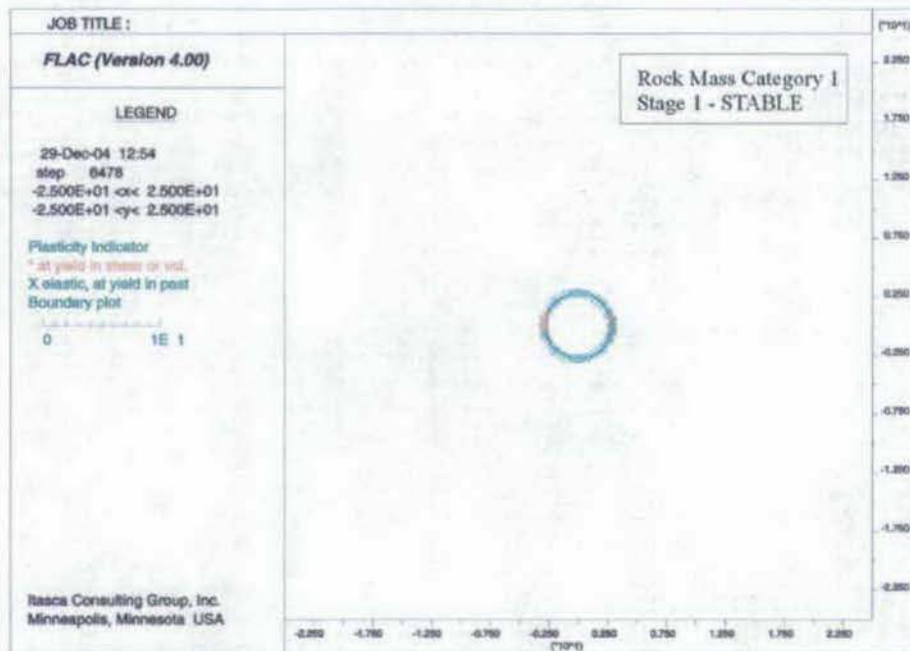

Output DTN: MO0506SPACRITL.000.

Figure G-5. Extent of Plastic Zone for Stage 1 (After Excavation of the Drift) for Rock Mass Category 1 and Perfectly Plastic Behavior

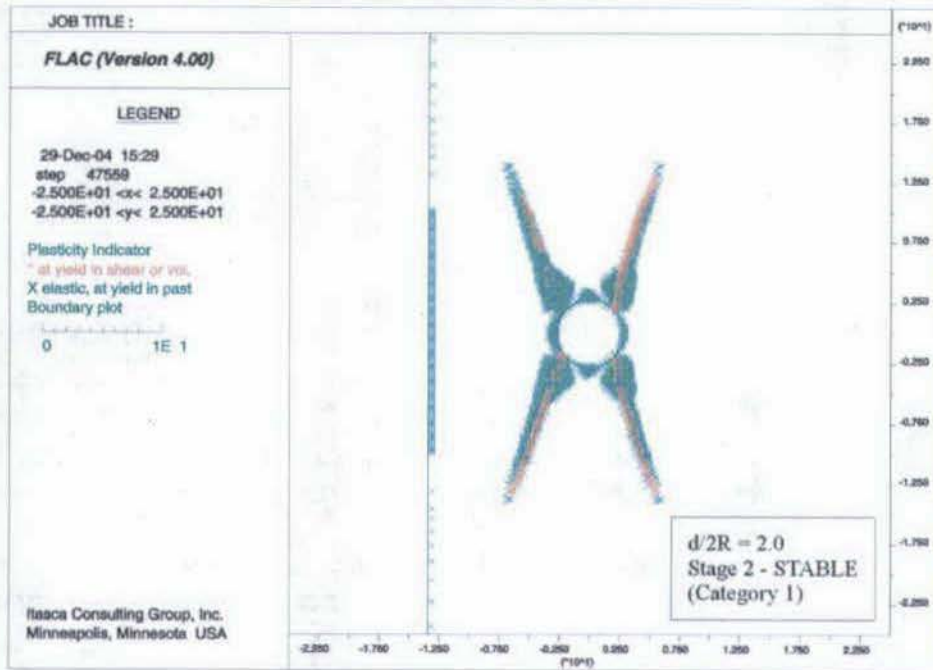

Output DTN: MO0506SPACRITL.000.

Figure G-6. Extent of Plastic Zone for Stage 2 (Rock Mass Category 1 and Perfectly Plastic Behavior) in the Case $d/2R = 2.0$

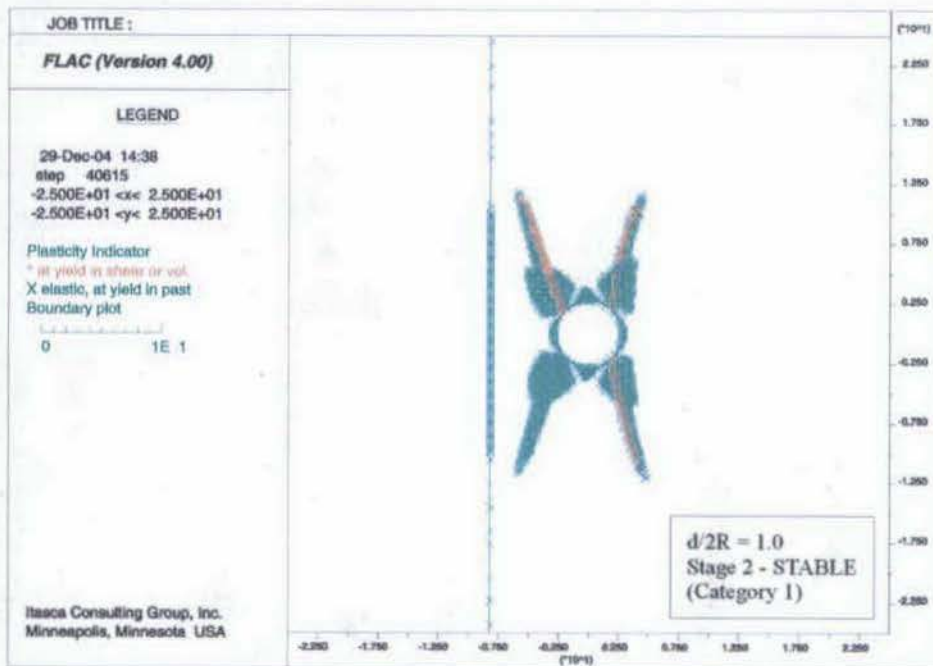

Output DTN: MO0506SPACRITL.000.

Figure G-7. Extent of Plastic Zone for Stage 2 (Rock Mass Category 1 and Perfectly Plastic Behavior) in the Case $d/2R = 1.0$

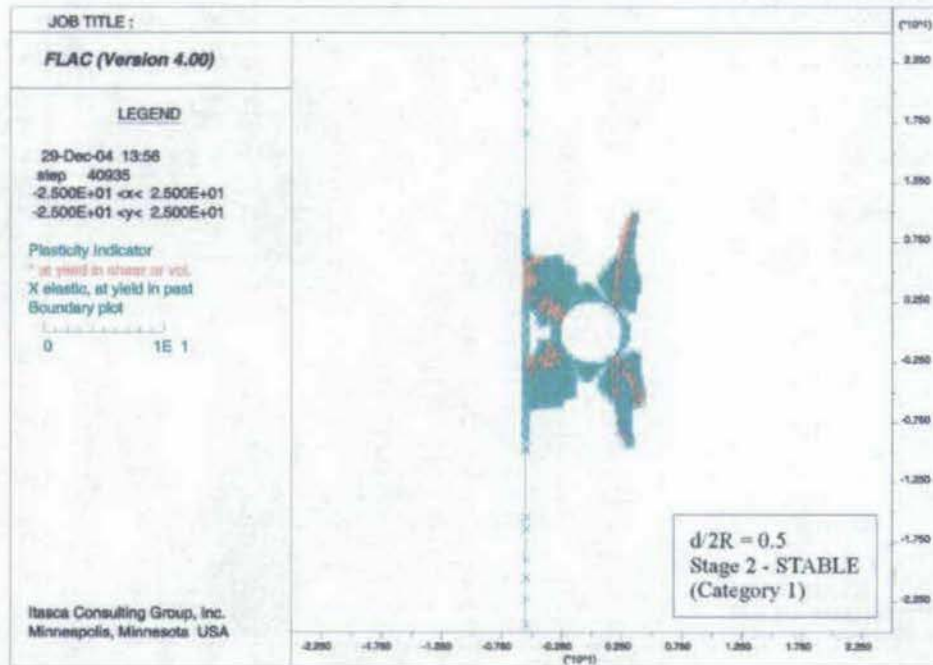

Output DTN: MO0506SPACRITL.000.

Figure G-8. Extent of Plastic Zone for Stage 2 (Rock Mass Category 1 and Perfectly Plastic Behavior) in the Case $d/2R = 0.5$

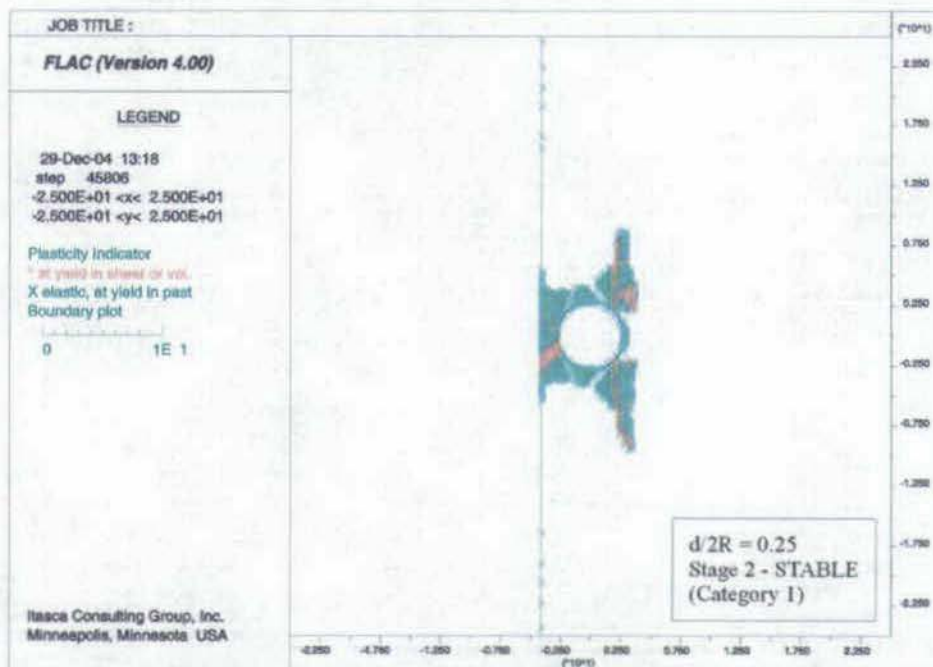

Output DTN: MO0506SPACRITL.000.

Figure G-9. Extent of Plastic Zone for Stage 2 (Rock Mass Category 1 and Perfectly Plastic Behavior) in the Case $d/2R = 0.25$

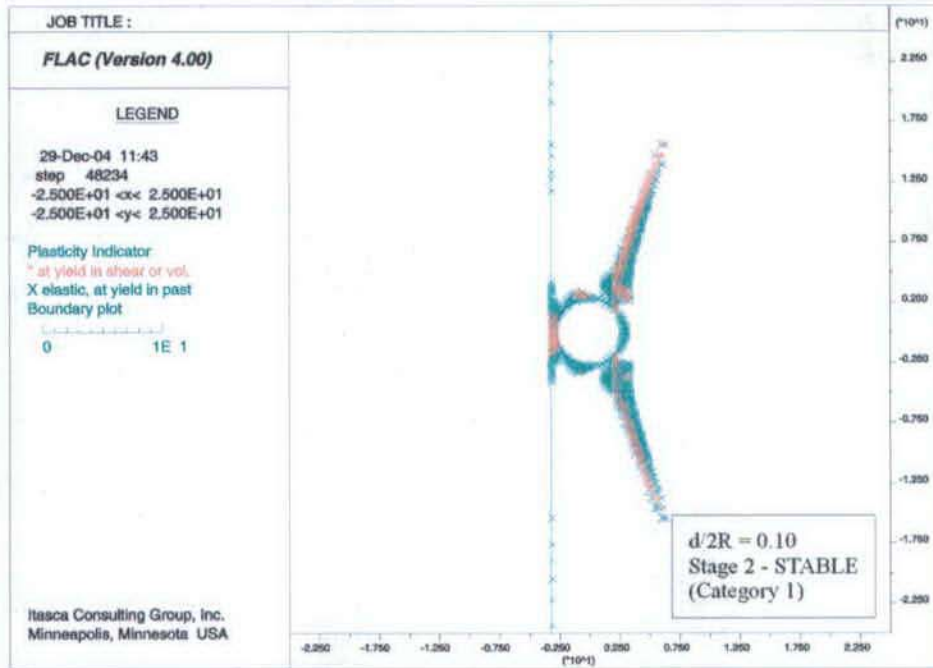

Output DTN: MO0506SPACRITL.000.

Figure G-10. Extent of Plastic Zone for Stage 2 (Rock Mass Category 1 and Perfectly Plastic Behavior) in the Case $d/2R = 0.10$

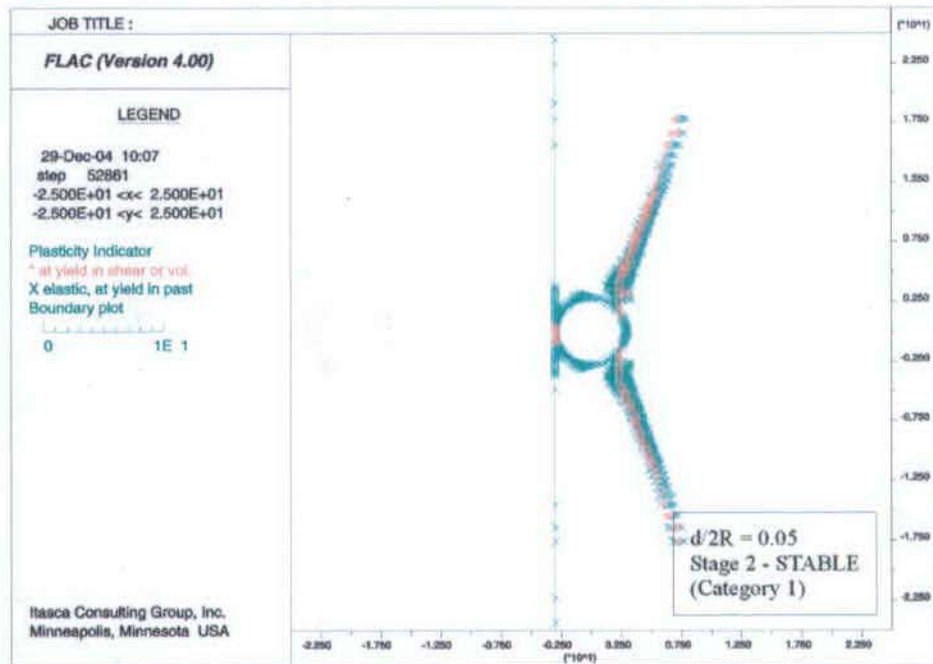

Output DTN: MO0506SPACRITL.000.

Figure G-11. Extent of Plastic Zone for Stage 2 (Rock Mass Category 1 and Perfectly Plastic Behavior) in the Case $d/2R = 0.05$

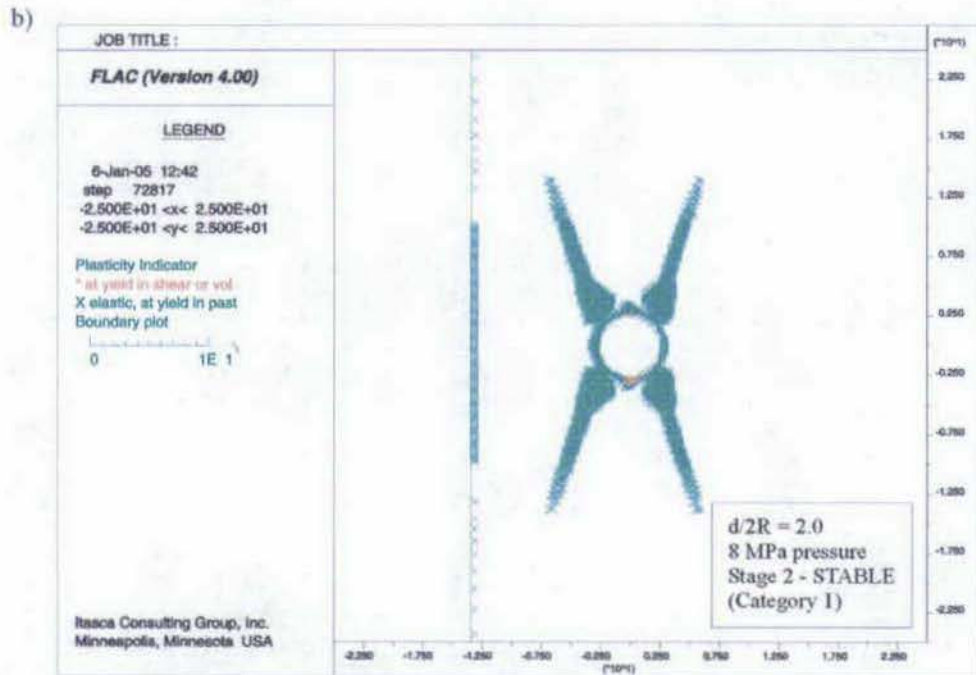
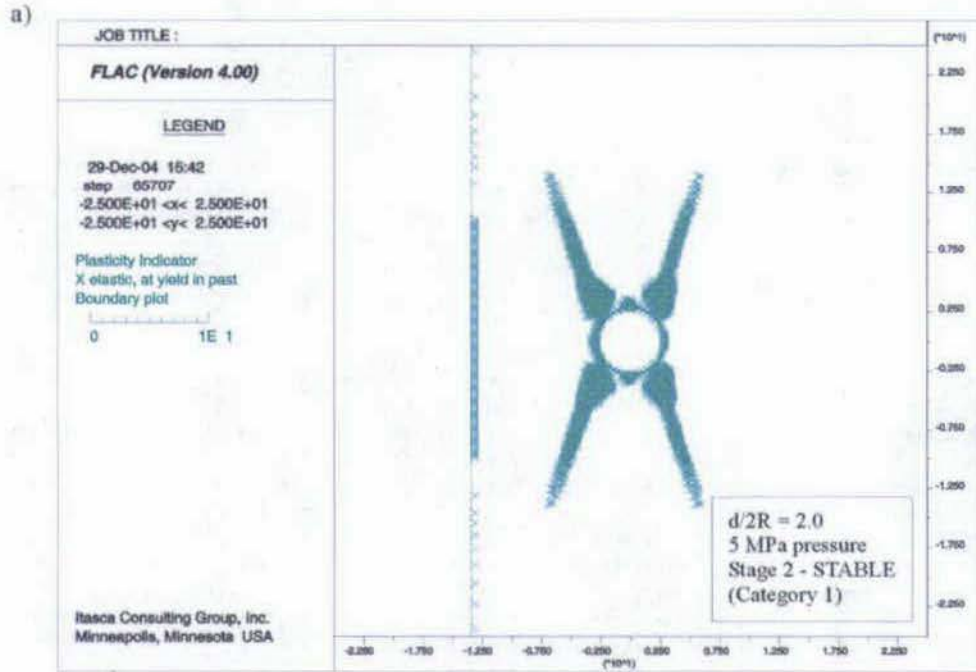

Output DTN: MO0506SPACRITL.000.

NOTE: a) Corresponds to the nominal case of lateral pressure, 5 MPa; b) corresponds to extreme case of lateral pressure, 8 MPa.

Figure G-12. Extent of Plastic Zone for Stage 3 (Rock Mass Category 1 and Perfectly Plastic Behavior) in the Case $d/2R = 2.0$

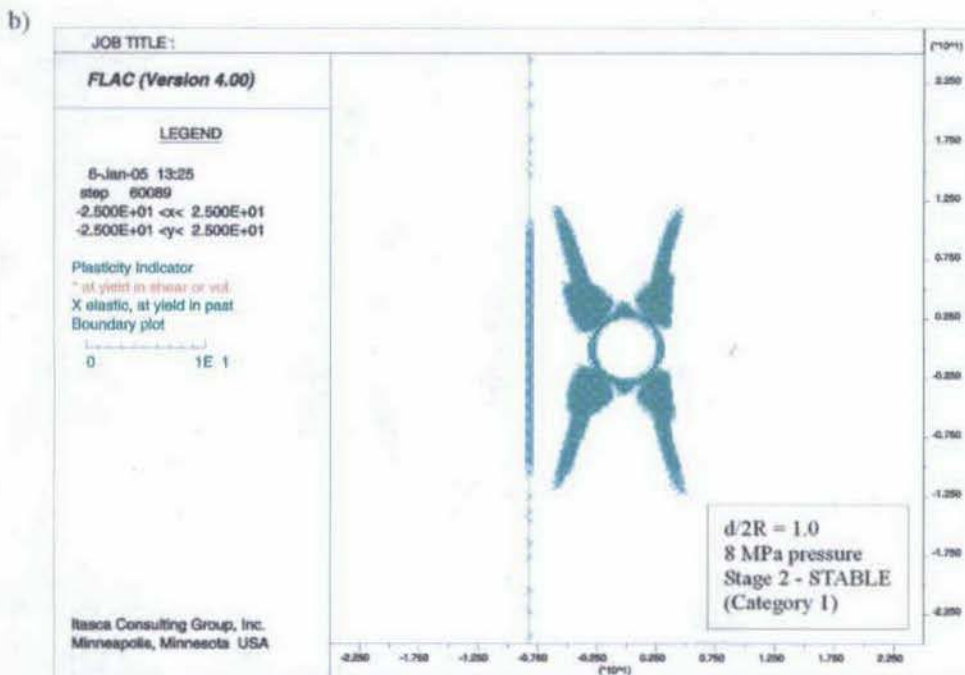
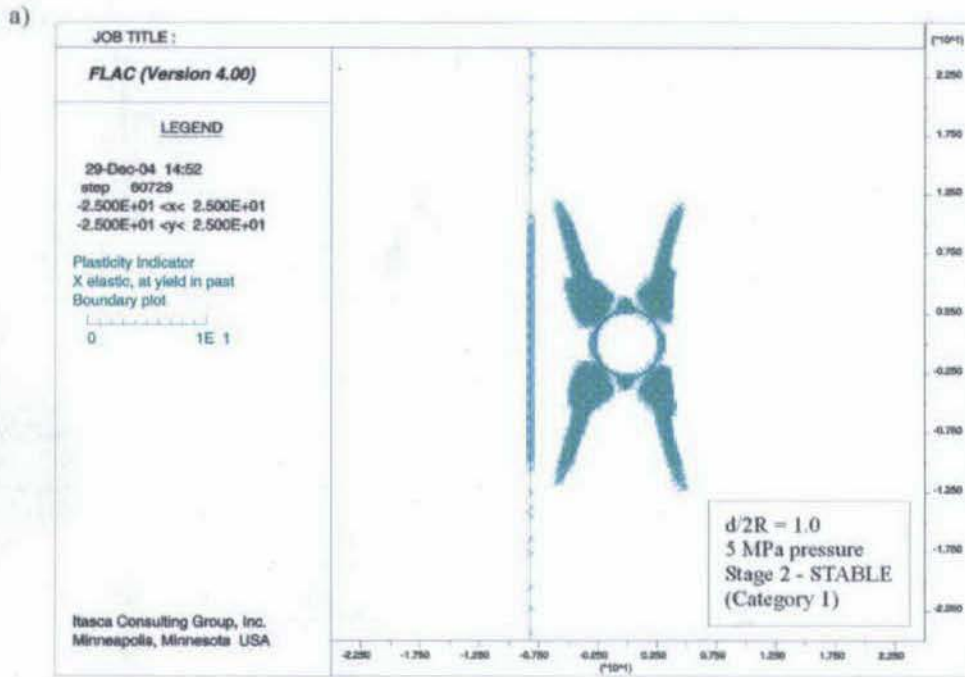

Output DTN: MO0506SPACRITL.000.

NOTE: a) Corresponds to the nominal case of lateral pressure, 5 MPa; b) corresponds to extreme case of lateral pressure, 8 MPa.

Figure G-13. Extent of Plastic Zone for Stage 3 (Rock Mass Category 1 and Perfectly Plastic Behavior) in the Case $d/2R = 1.0$

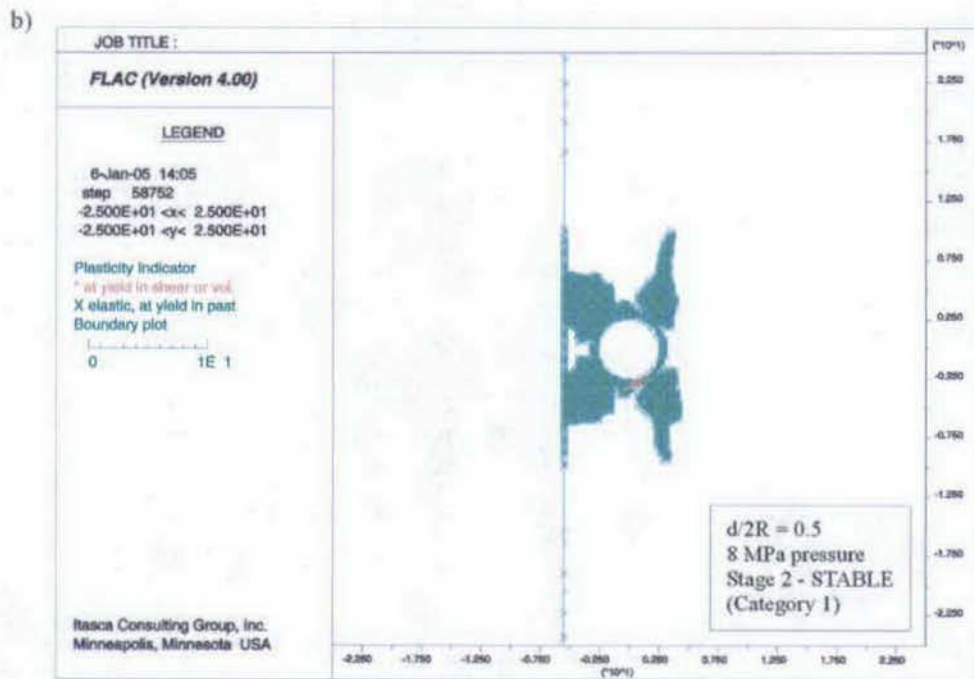
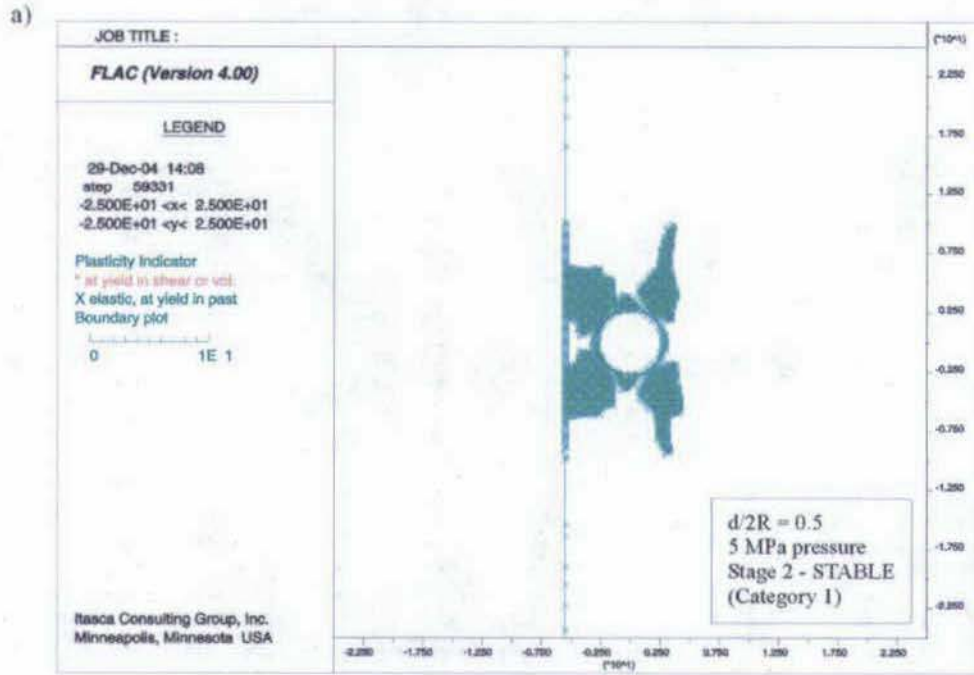

Output DTN: MO0506SPACRITL.000.

NOTE: a) Corresponds to the nominal case of lateral pressure, 5 MPa; b) corresponds to the extreme case of lateral pressure, 8 MPa.

Figure G-14. Extent of Plastic Zone for Stage 3 (Rock Mass Category 1 and Perfectly Plastic Behavior) in the Case $d/2R = 0.5$

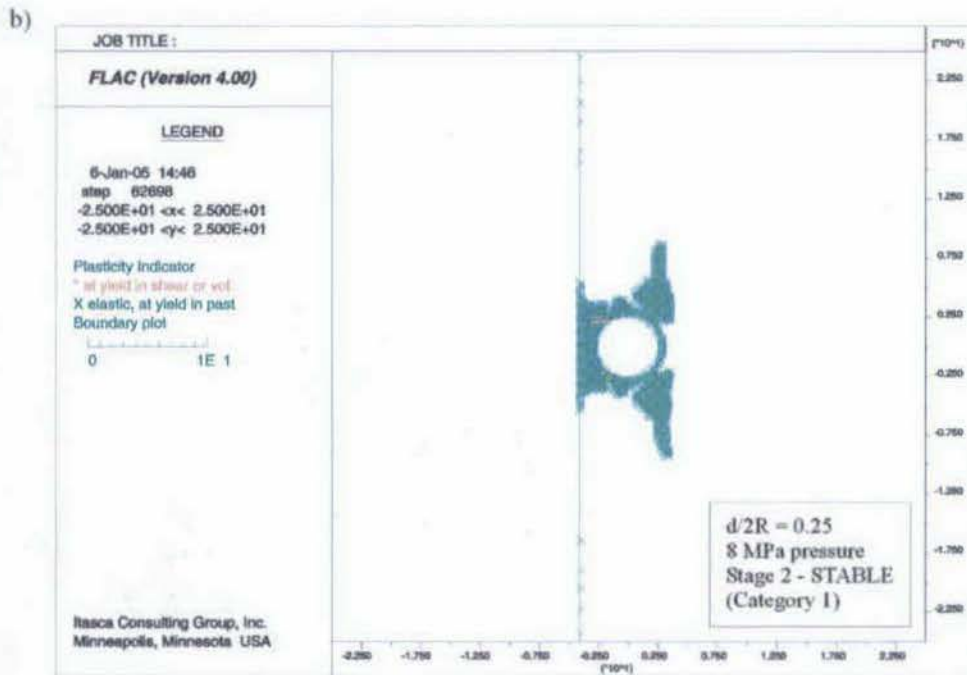
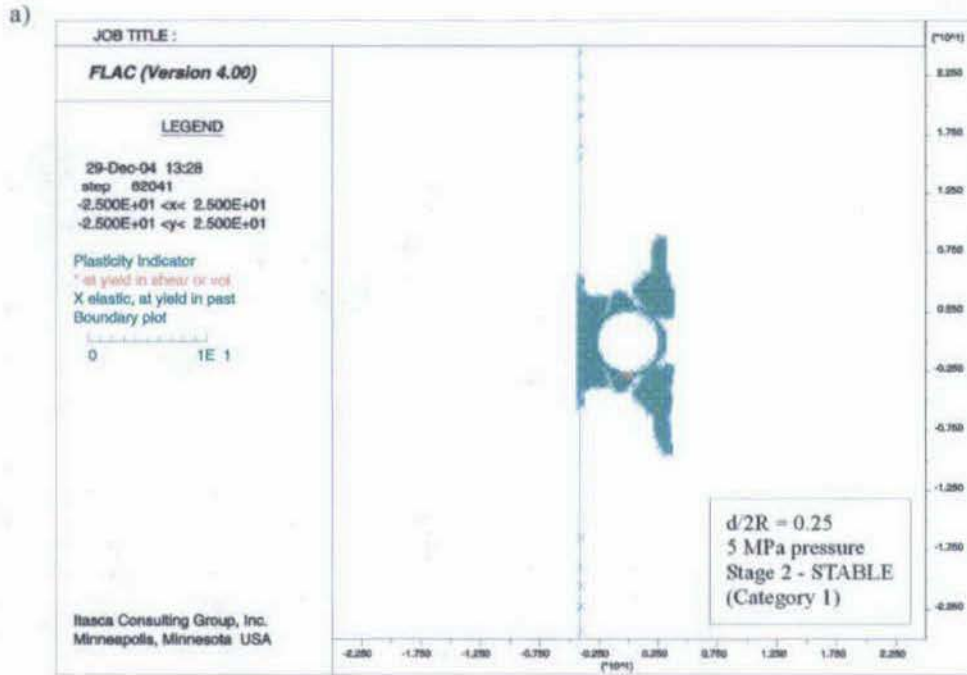

Output DTN: MO0506SPACRITL.000.

NOTE: a) Corresponds to the nominal case of lateral pressure, 5 MPa; b) corresponds to the extreme case of lateral pressure, 8 MPa.

Figure G-15. Extent of Plastic Zone for Stage 3 (Rock Mass Category 1 and Perfectly Plastic Behavior) in the Case $d/2R = 0.25$

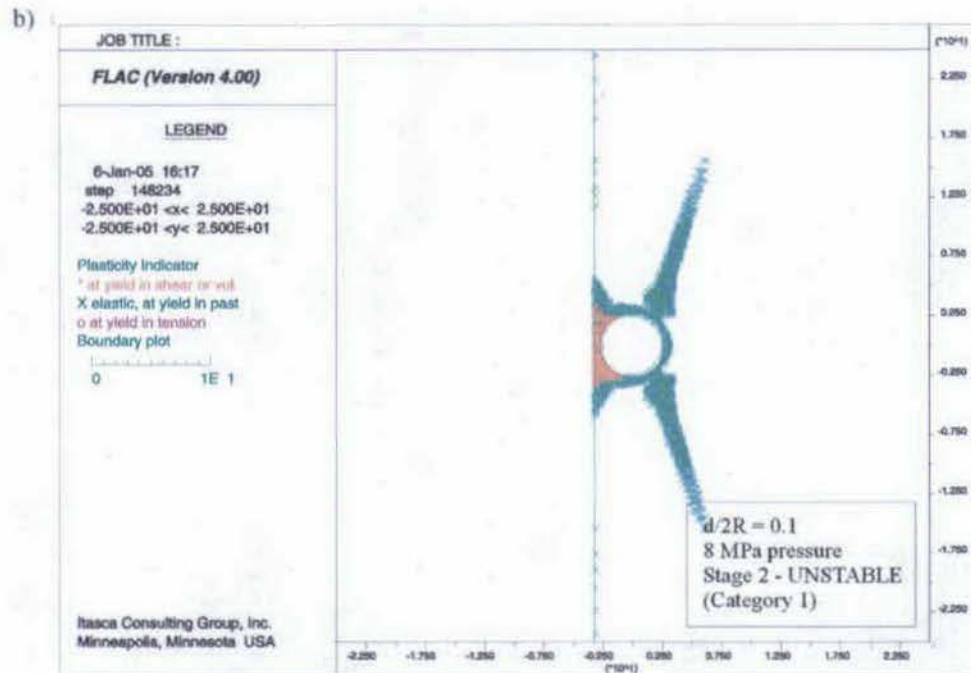
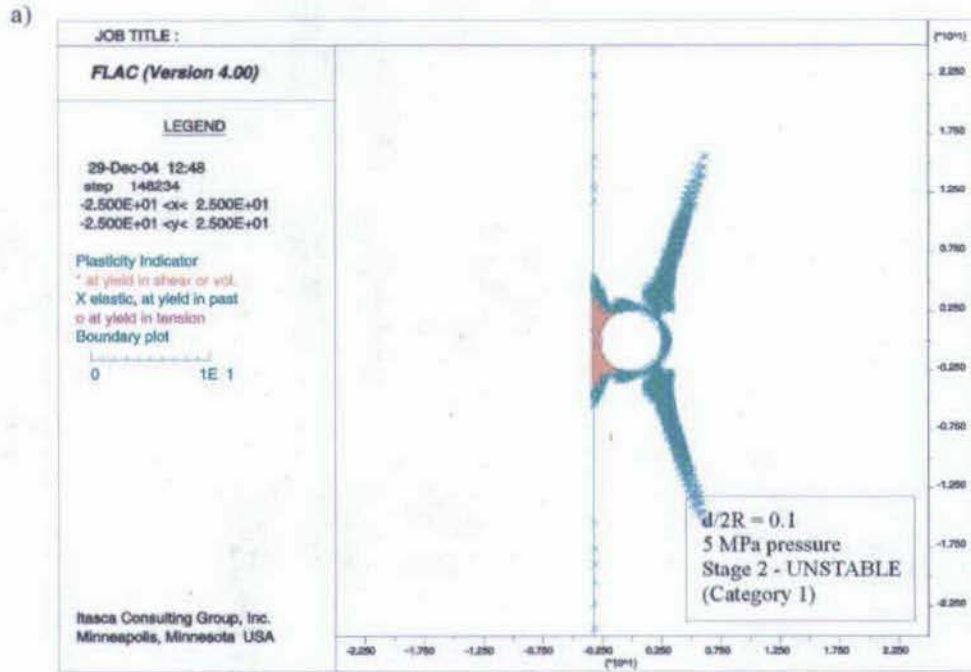

Output DTN: MO0506SPACRITL.000.

NOTE: a) Corresponds to the nominal case of lateral pressure, 5 MPa; b) Corresponds to the extreme case of lateral pressure, 8 MPa.

Figure G-16. Extent of Plastic Zone for Stage 3 (Rock Mass Category 1 and Perfectly Plastic Behavior) in the Case $d/2R = 0.10$

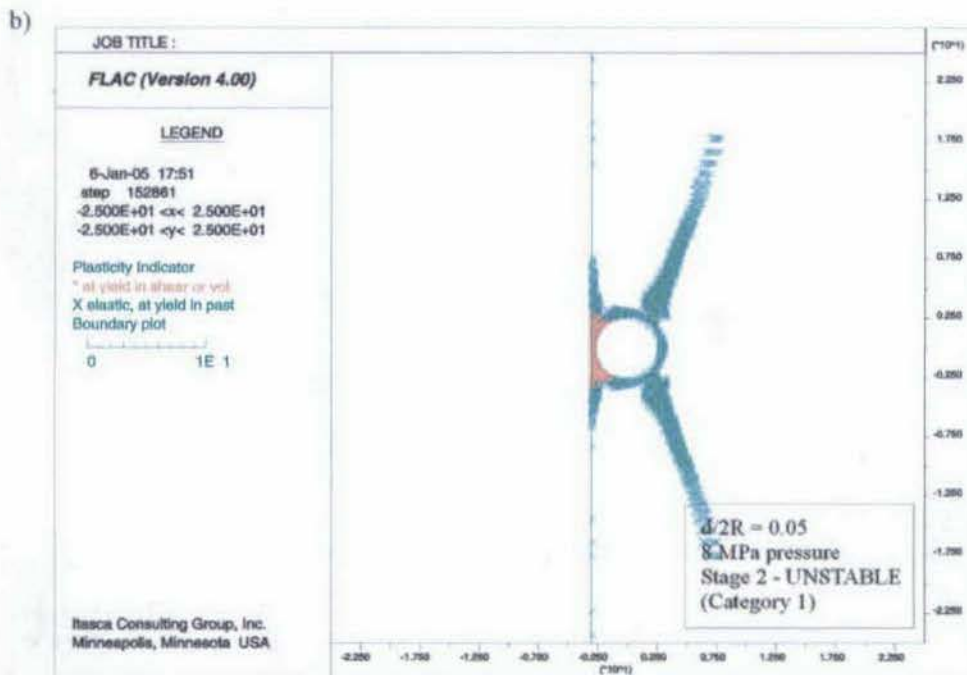
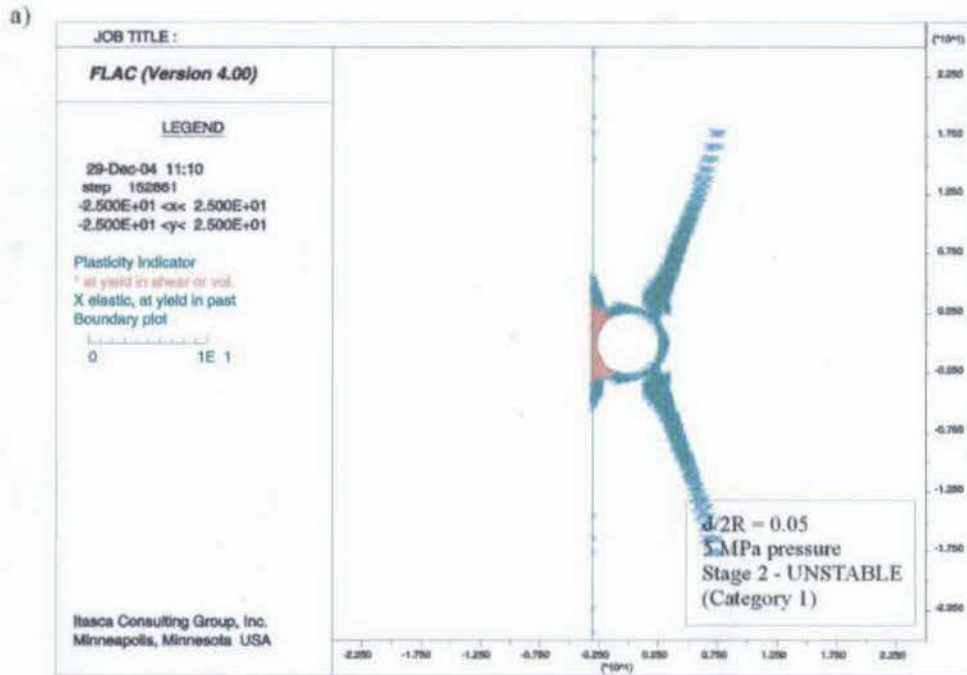

Output DTN: MO0506SPACRITL.000.

NOTE: a) Corresponds to the nominal case of lateral pressure, 5 MPa; b) corresponds to the extreme case of lateral pressure, 8 MPa.

Figure G-17. Extent of Plastic Zone for Stage 3 (Rock Mass Category 1 and Perfectly Plastic Behavior) in the Case $d/2R = 0.05$

The problem also was analyzed for the intermediate rock mass, Category 3, and the best-quality rock mass, Category 5, using both a perfectly plastic and a perfectly brittle behavior with the value of residual cohesion taken to be 50% of the value indicated in Table G-1. However, only the results for perfectly brittle behavior, as more representative of Categories 3 and 5, are reported here. The extreme situation in Stage 3 (i.e., 8 MPa of lateral pressure) was inspected. The results of these calculations, summarized in Tables G-3 and G-4, show that the pillar remains stable even when the dike is very close to the drift (1.375 m or less). Inspection of the plastic deformation (i.e., damage) of the pillar (illustrated in Figures G-18 and G-19 for Category 3 and in Figures G-20 and G-21 for Category 5) indicates that a portion of the pillar clearly remains elastic for $d/2R = 0.5$ in Category 3 and for $d/2R = 0.25$ in Category 5.

Table G-3. Stability Conditions Obtained with FLAC for the Pillar between the Dike and the Drift for Rock Mass Category 3 and Perfectly Brittle Behavior, with Residual Cohesion 50 Percent of the Peak Cohesion

$d/2R$	d (m)	Stage 1	Stage 2	Stage 3 (8 MPa)
2.0	11	Stable	Stable	Stable
1.0	5.5		Stable	Stable
0.5	2.75		Stable	Stable
0.25	1.375		Stable	Broken, stable
0.10	0.55		Broken, stable	Unstable
0.05	0.275		Broken, stable	Unstable

Output DTN: MO0506SPACRITL.000.

Table G-4. Stability Conditions Obtained with FLAC for the Pillar between the Dike and the Drift for Rock Mass Category 5 and Perfectly Brittle Behavior, with Residual Cohesion 50 Percent of the Peak Cohesion

$d/2R$	d (m)	Stage 1	Stage 2	Stage 3 (8 MPa)
2.0	11	Stable	Stable	Stable
1.0	5.5		Stable	Stable
0.5	2.75		Stable	Stable
0.25	1.375		Stable	Stable
0.10	0.55		Broken, stable	Unstable
0.05	0.275		Broken, stable	Unstable

Output DTN: MO0506SPACRITL.000.

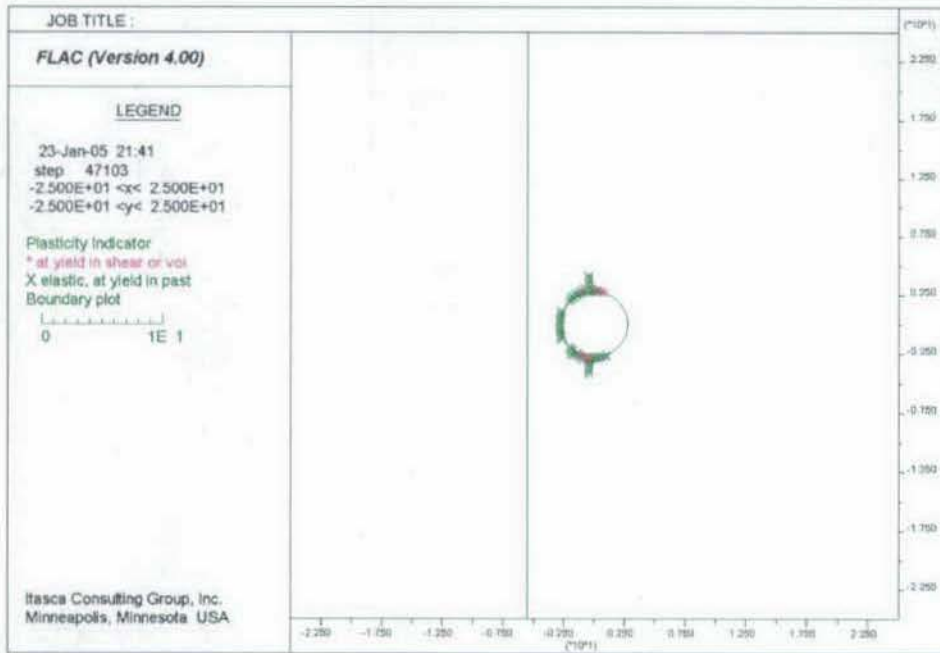

Output DTN: MO0506SPACRITL.000.

Figure G-18. Extent of Plastic Zone for Stage 3, Lateral Pressure 8 MPa, in the Case $d/2R = 0.5$ (Rock Mass Category 3 and Brittle Behavior with 50 Percent Reduction of Cohesion)

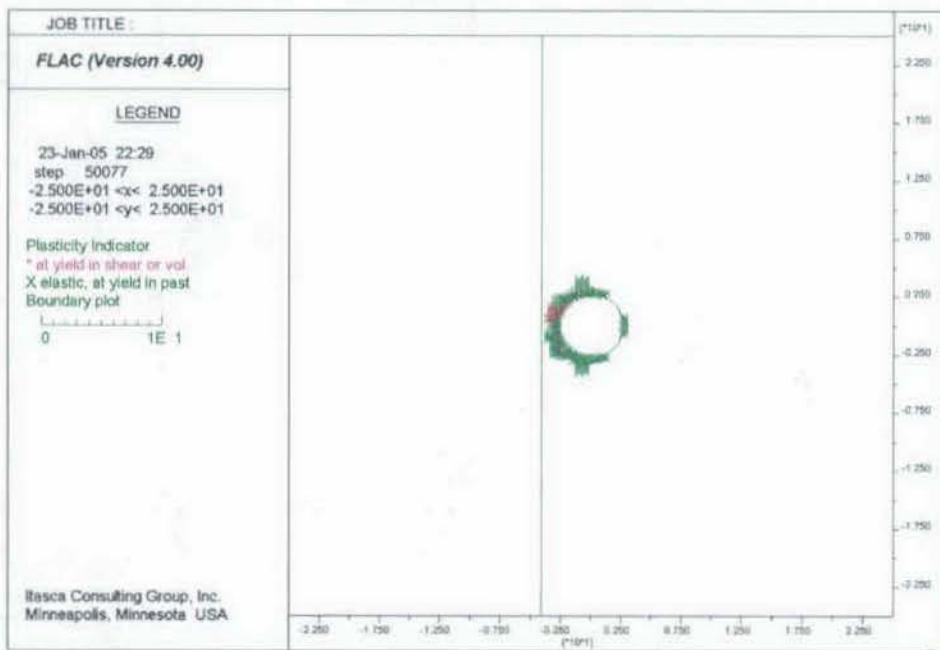

Output DTN: MO0506SPACRITL.000.

Figure G-19. Extent of Plastic Zone for Stage 3, Lateral Pressure 8MPa, in the Case $d/2R = 0.25$ (Rock Mass Category 3 and Brittle Behavior with 50 Percent Reduction of Cohesion)

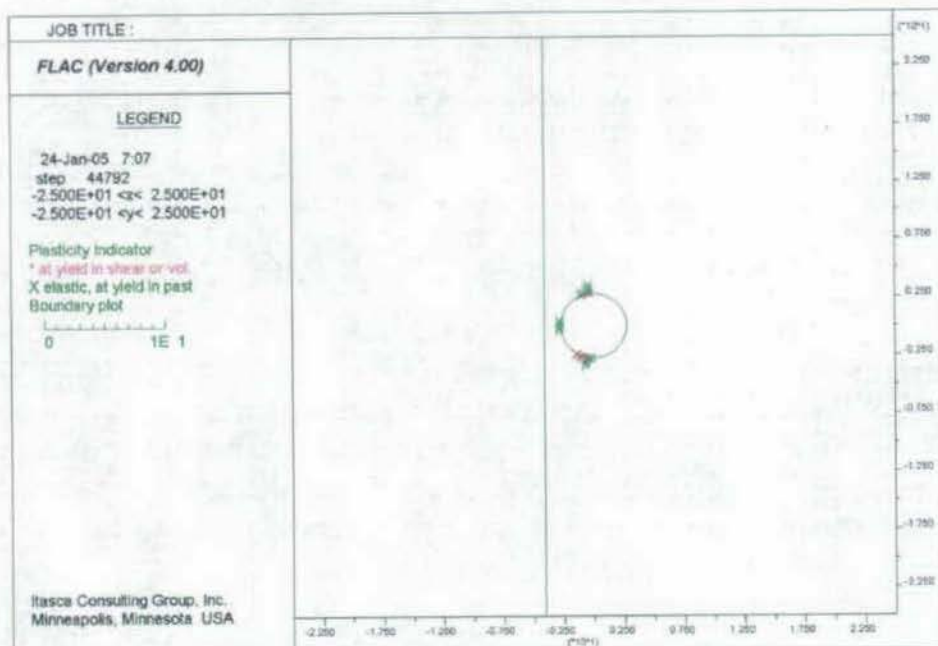

Output DTN: MO0506SPACRITL.000.

Figure G-20. Extent of Plastic Zone for Stage 3, Lateral Pressure 8MPa, in the Case $d/2R = 0.25$ (Rock Mass Category 5 and Brittle Behavior with 50 Percent Reduction of Cohesion)

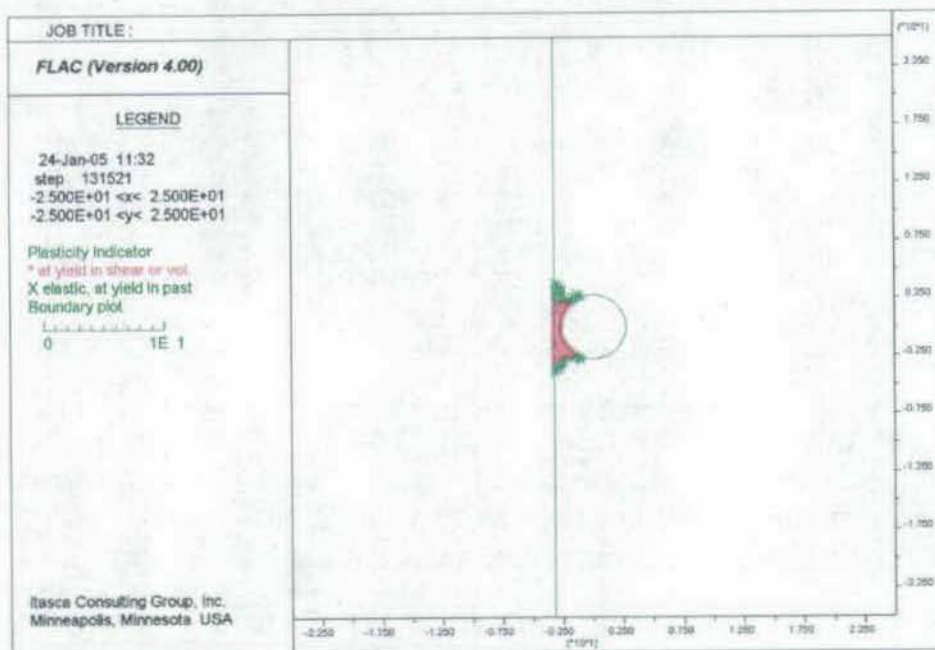

Output DTN: MO0506SPACRITL.000.

Figure G-21. Extent of Plastic Zone for Stage 3, Lateral Pressure 8MPa, in the Case $d/2R = 0.10$ (Rock Mass Category 5 and Brittle Behavior with 50 Percent Reduction of Cohesion)

G.4 TEMPERATURE EFFECT

The analysis of pillar stability was carried out assuming the mechanical properties of the lithophysal rock mass at the in situ temperature, which is approximately 20°C. The mechanical properties of the rocks are temperature dependent. In general, the strength and stiffness of the rock decrease as the temperature increases. The temperature dependence of the mechanical properties of the lithophysal rock mass is not available currently. However, Rocchi et al. (2004 [DIRS 173995]) report that the mechanical properties of basalt are not affected when heated to approximately 600°C.

The ascending dike will heat the surrounding rock mass to a certain distance from the dike wall. The distance to which the thermal effect of the dike is propagated into the wall is a function of time. If the magma temperature, T_0 , is 1,379 K and the initial temperature of the rock mass, T_i , is 293 K, the distance from the dike wall of the surface corresponding to the $T(x,t)$ of 873°K (i.e., if the temperature dependence of the strength of lithophysal rock mass were the same as for basalt) can be calculated from the following formula:

$$\frac{T(x,t) - T_0}{T_i - T_0} = \operatorname{erf}\left(\frac{x}{2\sqrt{\alpha t}}\right) \quad (\text{Eq. G-1})$$

where α is the thermal diffusivity, x is the distance, and t is time. In this particular case,

$$\frac{T(x,t) - T_0}{T_i - T_0} = 0.47 \quad (\text{Eq. G-2})$$

which yields

$$x = 2 \times 0.44\sqrt{\alpha t} \quad (\text{Eq. G-3})$$

The thermal diffusivity can be calculated as

$$\alpha = \frac{k}{c\rho} \quad (\text{Eq. G-4})$$

where thermal conductivity, k , is approximately 1.28 W/mK (DTN: SN0404T0503102.011 [DIRS 169219], Table 7-10); specific heat, c , is 985 J/kg K (DTN: SN0402T0503102.010 [DIRS 170993], file: *SN_new_DTN.xls*); and density, ρ , is 1,979 kg/m³ (DTN: SN0404T0503102.011 [DIRS 169129], Table 7-10).

A period of approximately 30 days (SNL 2007 [DIRS 174260], Section 6.3.4.4) is taken to be the duration of eruption. The calculation shows that roughly 1 m of the rock in the dike wall will be heated above 600°C after 30 days. Assuming that strength reduction as a function of temperature of the lithophysal tuff is similar to that of basalt, an initially stable (or unbroken) pillar will remain stable after 30 days if its thickness is increased by 1 m.

G.5 CONCLUSIONS

The estimates of the critical distances between the ascending dike and the emplacement drift when the pillar between the dike and the drift remains stable and unbroken, preventing the dike from intersecting the drift, are listed in Table G-5. These critical distances are increased to account for the thermal effects of heating on the rock mass strength. If the magma temperature of 1,379 K in the dike is sustained for 30 days, the critical distance should be increased by 1 m.

Table G-5. Calculated Critical Distances for Different Categories of Lithophysal Rock Mass

Category	Estimated Abundance (%)	Critical Distance for In Situ Temperature (m)	Critical Distance after 30 Days of Heating (m)
1 and 2	10	5.50	6.50
3 and 4	60	2.75	3.75
5	30	1.37	2.37

Output DTN: SN0701PAWPHIT1.001, file: *Dike-drift critical distance in lithophysal.xls*.

The entire analysis was performed for different categories of lithophysal rock mass. The nonlithophysal rock mass, which represents approximately 15% of the entire repository horizon, has mechanical properties equal or better than lithophysal rock mass Category 5. The analysis for the nonlithophysal rock mass probably would indicate that the critical pillar width at zero time (i.e., the short time after the dike passes by the repository horizon) can be even smaller than 1.375 m. Considering uncertainties in the input parameters and idealizations used in the calculations, this distance may be too small. The calculation represents the rock mass as a continuum, whereas the actual rock mass is discrete. In the case of a narrow pillar, there is a possibility of fractures connecting the dike and the drift, resulting in instability and flow of magma from the dike into the drift. Therefore, it is recommended that the critical distance in the nonlithophysal rock mass be the same as for the lithophysal rock mass, Category 5.

The conservatism of the results of the critical distance calculations is attributed to the following reasons.

1. It is assumed that the critical distances in Categories 2 and 4 of the lithophysal units are the same as the critical distances in Categories 1 and 3, respectively. Categories 2 and 4 have greater strengths than Categories 1 and 3, respectively, and the corresponding critical distances will be smaller.
2. The critical distance in the nonlithophysal units, which have greater strength than the lithophysal units, is assumed to be equal to the critical distance in Category 5, lithophysal rock mass.

3. The postpeak behavior of the rock mass (with exception of Categories 1 and 2) was assumed to be perfectly brittle. The rock mass at the repository level (irrespective of its brittleness) has a finite softening rate. The assumption of perfectly brittle material response results in greater critical distance.
4. In most of the cases analyzed, the critical distance was obtained for the 8 MPa magma pressure in the dike. This pressure can exist under extreme conditions when the dike or conduit is blocked at an elevation above the repository. Without a blockage, the maximum magma pressure at the repository level will be approximately 4 to 4.5 MPa.