

Calculation Cover Sheet

Complete only applicable items.

2. Calculation Title
Criticality Evaluation of Plutonium Disposition Ceramic Waste Form: Degraded Mode MOL.19980918.0003

3. Document Identifier (including Revision Number)
BBA000000-01717-0210-00014 REV 01 4. Total Pages
20

5. Total Attachments
2 6. Attachment Numbers - Number of pages in each
I-1, II-1 (See Box 10)

	Print Name	Signature	Date
7. Originator	Amir S. Mobasheran	<i>Amir S. Mobasheran</i>	9/18/98
8. Checker	John A. McClure	<i>John A. McClure</i>	9/15/98
9. Lead Design Engineer	Peter Gottlieb	<i>Peter Gottlieb</i>	9/18/98

10. Remarks
Attachment II is contained on a magnetic tape (Ref. 9). The page number shown for Attachment II in box 6 refers to the number of pages in the hardcopy listing of the contents of the magnetic tape (Ref. 9).

REG COMPLIANCE CHECK 9/18/98 W. French

Revision History

11. Revision No.	12. Date Approved	13. Description of Revision
REV 00 REV 01	09/10/98	Initial Issue This revision incorporates the criticality evaluation of six additional cases for the full degradation configurations.

TABLE OF CONTENTS

<u>ITEM</u>	<u>PAGE</u>
1. PURPOSE	5
2. METHOD	5
3. ASSUMPTIONS	5
4. USE OF COMPUTER SOFTWARE	7
4.1 Software Approved for QA Work	7
4.2 Software Routines	7
5. CALCULATION	7
5.1 Input Data	10
5.2 WP Degraded-Mode Configurations	10
5.2.1 Intermediate-Level Degradation Configurations	11
5.2.1.1 "Square" Geometry, Square Lattice Arrangement of Cans	11
5.2.1.2 Pseudo-Cylindrical Segment Geometry, "Square Lattice" Arrangement of Cans ..	11
5.2.1.3 Pseudo-Cylindrical Segment Geometry, "Square Lattice" Arrangement of Ceramic Disks	14
5.2.2 Full Degradation Configuration	14
6. RESULTS	16
6.1 Criticality Evaluation Results for the Intermediate-Level Degradation Configurations	17
6.2 Criticality Evaluation Results for the Full Degradation Configurations	17
7. REFERENCES	18
8. ATTACHMENTS	20

LIST OF FIGURES

<u>ITEM</u>	<u>PAGE</u>
Figure 5-1. 5 HLW Canister WP Design	8
Figure 5-2. Can-in-Canister Assembly	9
Figure 5.2.1.1-1. A Cross-sectional Front View of a Horizontally Emplaced Waste Package Depicting a Square Lattice Arrangement of Cans in a "Square" Geometry	12
Figure 5.2.1.1-2. A Cross-sectional Side View of a Horizontally Emplaced Waste Package for the Square Lattice Arrangement of Cans in a "Square" Geometry	13
Figure 5.2.1.1-3. A Cross-section of a Can Containing the 20 Ceramic Disks.....	13
Figure 5.2.1.2-1. A Cross-sectional Front View of a Horizontally Emplaced Waste Package Depicting a "Square Lattice" Arrangement of Cans in a Pseudo-Cylindrical Segment Geometry	14
Figure 5.2.2-1. A Cross-sectional Front View of a Horizontally Emplaced Waste Package for the Full Degradation Configuration	15

LIST OF TABLES

<u>ITEM</u>	<u>PAGE</u>
Table 5.1-1. The Physical Characteristics of the Main Components of the 5 High-Level Waste Canister Waste Package	10
Table 5.2.2-1. The Most Abundant Elements or Isotopes Present in the Sludge.....	16
Table 6.1-1. k_{eff} Estimates for Intermediate-Level Degradation Configuration: Square Geometry	17
Table 6.1-2. k_{eff} Estimates for Intermediate-Level Degradation Configuration: Pseudo Cylindrical Segment Geometry	17
Table 6.2-1. k_{eff} Estimates for the Full Degradation Configurations with Partial Gd Loss	18
Table 6.2-2. k_{eff} Estimates for the Full Degradation Configurations with no Gd Present.....	18

1. PURPOSE

The purpose of this calculation is to perform degraded mode criticality evaluations of plutonium disposed in a ceramic waste form and emplaced in a Monitored Geologic Repository (MGR). A 5 Defense High-Level Waste (DHLW) Canister Waste Package (WP) design, incorporating the can-in-canister concept for plutonium immobilization is considered for this calculation. Each HLW glass pour canister contains 7 tubes. Each tube contains 4 cans, with 20 ceramic disks (immobilized plutonium) in each. The criticality evaluations estimate the values of the effective neutron multiplication factor, k_{eff} , for different degraded internal WP configurations.

2. METHOD

The following methodology is adopted to estimate the values of the effective neutron multiplication factor, k_{eff} , for different degraded internal configurations of the WP:

- (a) computational models, representing different degraded internal configurations of the WP, are developed for the MCNP4B2 computer code;
- (b) spreadsheet calculations are conducted on the results of the EQ3/6 geochemistry analysis (Ref. 1) to determine the amount of chemical elements or isotopes, their total mass, their total volume, and the density of the homogenized mixture for each case of interest to be incorporated in the computational models developed in (a); and
- (c) the MCNP4B computer code, appropriate for performing nuclear criticality analysis, is run, for the computational models developed above, to estimate the k_{eff} value and its corresponding standard deviation for each model.

This document has been prepared according to Procedure NLP-3-27, REV 1, Engineering Calculations, and is not subject to the Quality Assurance Requirements and Description (QARD) Document (DOE/RW-0333P, REV 08).

3. ASSUMPTIONS

The assumptions used to perform the WP degraded mode criticality investigation are as listed below:

- 3.1 It is assumed that the worst-case configuration can be represented when the five stainless steel canisters and their HLW contents are degraded and the 35 columns of 4 stacked cans (containing the ceramic disks) are settled in the bottom segment of the horizontally-emplaced WP, creating a square lattice. This is a conservative assumption, as the compact geometry of the fissile material is at its maximum (minimizing the neutron leakage) and the absorption of the neutrons by the other degradation products (degraded stainless steel and HLW, with water or dry, in the remaining volume of the WP) is ignored. The choice of square lattice, as the worst-case configuration is justified, as a hexagonal lattice (a more close-packed configuration than square lattice configuration) is much less likely to occur. In other words, while square lattice is less conservative than a

“circular” lattice, the former is more likely than the latter since the latter is gravitationally impossible. This assumption was used in Section 5.2.1.1.

- 3.2** It is assumed that, representing fully collapsed, but still intact, disks, the five stainless steel canisters and their HLW contents are degraded and the intact 35 columns of 4 stacked cans (containing the ceramic disks) are settled in the bottom segment of the horizontally-emplaced WP creating a pseudo-cylindrical segment geometry. The degradation products and the non-degraded portions of the other WP internals, with water or dry in the rest of WP, are ignored. The WP is filled with water. This conservative assumption is similar to Assumption 3.1 above, but the geometry of the settled cans in the current assumption is more “natural” or “reasonable” than that in Assumption 3.1. In other words, while Assumption 3.2 is less conservative than Assumption 3.1, the latter is more realistic (because of gravitational stability). The stacks of cans are shifted downward and touch the inner barrier of the WP, in the absence of any corrosion products. This assumption was used in Section 5.2.1.2.
- 3.3** It is assumed that further degradation of the configuration represented by Assumption 3.2 above results in the loss of all the stainless steel cans, but the ceramic disks maintain their original (intact) positions, and the WP is filled with water. This assumption is more conservative than Assumption 3.2, because the stainless steel cans, when present, can contribute to neutron absorption. It is noted that this configuration would not be as conservative as it could be, if stacks of disks were moved to touch one another peripherally. However, the configuration assumed (no change in the original pitch) is more likely to occur in long term. This assumption was used in Section 5.2.1.3.
- 3.4** It is assumed that the final stage of degradation can be represented by a mixture of degradation products and non-degraded materials settled in the bottom segment of the WP, producing a uniform “sludge.” The basis for this assumption is the degradation rates of materials. This assumption was made to study the impact of a homogenized mixture on the k_{eff} of the system. This assumption is conservative, as the void space in the mixture is ignored (otherwise, water fills the void space and the neutron poisons [Hf and Gd] would act more effectively). This assumption was used in Section 5.2.2.
- 3.5** It is assumed that the homogenized mixture settled in the bottom segment of the WP, as indicated in Assumption 3.4, contains porosity and water fills the void space. This assumption was made to study the impact of the addition of water (to the homogenized mixture of degradation products and non-degraded materials) on the k_{eff} of the system. This assumption is conservative, as the range of porosity considered (0 to 60 percent water by volume) covers the extent of all void space possible. This assumption was used in Section 5.2.2.
- 3.6** It is assumed that, regarding the composition of the ceramic disks, Oxygen (O-16) represents the chemical elements: Cerium (Ce), Lanthanum (La), and Zinc (Zn), as well as representing the unknown portion of the composition. The basis for this assumption is that the said elements are missing from the MCNP4B2 cross section library and they,

along with the unknown portion of the composition, should be properly represented by substitute elements. This assumption is conservative, as O-16 has a lower thermal neutron absorption cross-section than the elements it replaces. This assumption was used throughout Section 5.

4. USE OF COMPUTER SOFTWARE

4.1 Software Approved for QA Work

The calculation of k_{eff} of degraded internal WP configurations was performed with the MCNP4B2 computer code (Computer Software Configuration Item [CSCI] 30033V4B2LV; [Ref. 2]). MCNP is a three-dimensional Monte Carlo particle transport program with a generalized geometry capability that allows the development of detailed, accurate models of the systems of interest. MCNP4B2 calculates k_{eff} for a variety of geometric configurations with neutron cross sections for elements and isotopes described in the Evaluated Nuclear Data File Version B-V (ENDF-B/V). MCNP4B2 is appropriate for the fissile isotopes involved in the geometries, and materials required for these analyses. The calculations using the MCNP4B2 software were executed on a Hewlett-Packard workstation. The software qualification of the MCNP4B2 software is summarized in the Software Qualification Report for the Monte Carlo N-Particle Code (Ref. 2). The MCNP4B2 evaluations performed for this calculation, while not within the range of MCNP Software Qualification Report (Ref. 2), are appropriate for the MCNP physics models. Access to and use of the MCNP4B2 software for this analysis was granted by Software Configuration Management (SCM) and performed in accordance with the QAP-SI series procedures. The names and location of the electronic copies of the MCNP4B2 output files (containing their corresponding echoed input files) are provided in Section 8.

4.2 Software Routines

Microsoft Excel 97, loaded on a 266MHz Pentium II PC. Arithmetic calculations of the elements and isotopes contained in the ceramic disks, corrosion product volumes, and masses are performed electronically in this spreadsheet software package. The names and location of the electronic copies of the spreadsheet files are provided in Section 8.

5. CALCULATION

The degraded mode criticality evaluations are performed for a 5 Defense High-Level Waste (DHLW) Canister WP design (Figure 5-1) which incorporates the can-in-canister concept for plutonium immobilization. The initial configuration of each HLW glass pour canister contains 7 tubes. Each tube contains 4 cans, with 20 ceramic disks (immobilized plutonium) in each. Figure 5-2 shows the can-in-canister assembly.

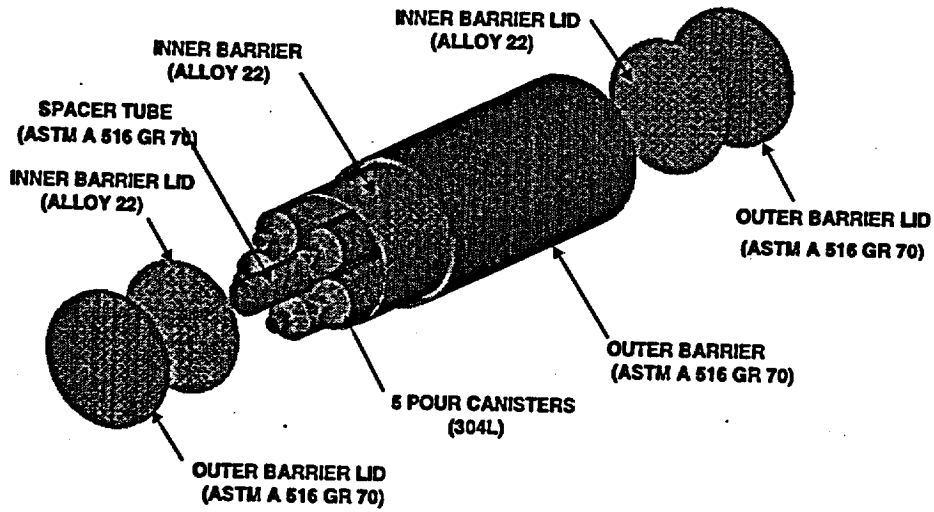

Figure 5-1. 5-DHLW Canister WP Design

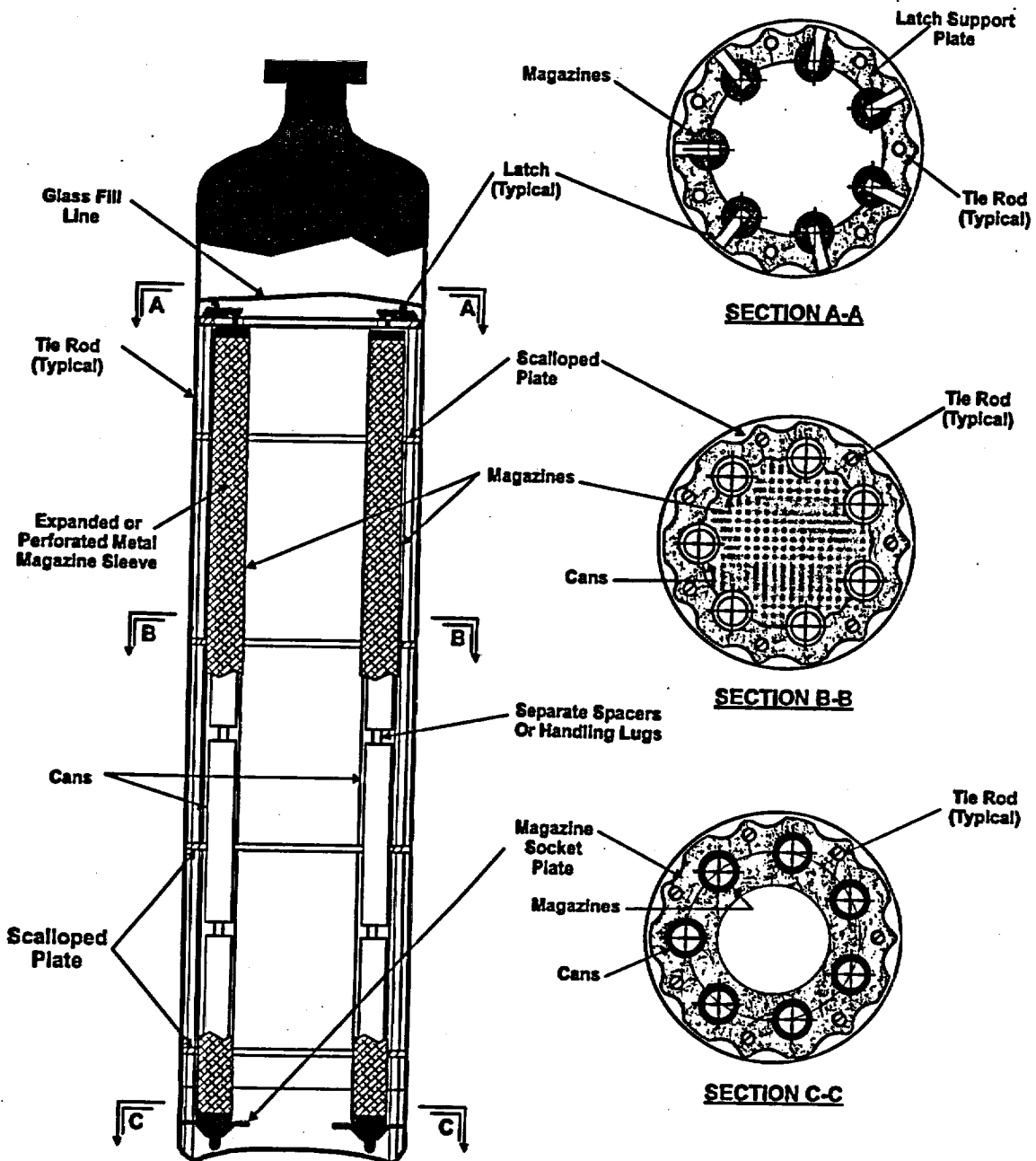

Figure 5-2. Can-in-Canister Assembly

5.1 Input Data

The dimensions and compositions of the intact WP components are provided in Table 5.1-1. The composition of the ceramic disks is provided in the form of a spreadsheet (Ref. 8).

Table 5.1-1. The Physical Characteristics of the Main Components of the 5 High-Level Waste Canister Waste Package

Component	Number	Material	Density (g/cm ³)	Inner Diameter (cm)	Outer Diameter (cm)	Thickness (cm)	Inner Height (cm)	Outer Height (cm)
Outer Barrier	1	ASTM A 516 GR 70 Carbon Steel ^(l)	7.832 ^(a)	177 ^(l)	197 ^(l)	10.0 ^(l)	-----	331 ^(l)
Outer Barrier Lid	2 (top and bottom)	ASTM A 516 GR 70 Carbon Steel ^(l)	7.832 ^(a)	-----	197 ^(l)	11.0 ^(l)	-----	-----
Inner Barrier	1	ASTM B 575 (N06022 (Alloy C-22)) ^(l)	8.69 ^(b)	173 ^(l)	177 ^(l)	2.0 ^(l)	304 ^(l)	-----
Inner Barrier Lid	2 (top and bottom)	ASTM B 575 N06022 (Alloy C-22)) ^(l)	8.69 ^(b)	-----	177 ^(l)	2.5 ^(l)	-----	-----
Canister ^(g)	5	ASTM A312 Type 304L Stainless Steel ^(m)	7.9 ^(c)	59.055 ^(h)	60.96 ^(h)	0.9525 ^(h)	-----	299.72 ^(h)
HLW ^(g)	-----	High-Level (Waste glass)	2.73 ⁽ⁱ⁾	-----	-----	-----	-----	-----
Can	140 (28 per Canister) ^(e)	Type 316 L Stainless Steel ^(j)	7.9497 ^(d)	6.9850 ⁽ⁱ⁾	7.6200 ⁽ⁱ⁾	0.3175 ⁽ⁱ⁾	52.705 ⁽ⁱ⁾	53.340 ⁽ⁱ⁾
Ceramic Disk	2800 (20 per Can) ^(e)	Ceramic ^(k)	5.5 ^(e)	-----	6.6675 ^(e)	2.54 ^(e)	-----	2.54 ^(e)

- (a) Ref. 4, p. I-1.
- (b) Ref. 4, p. I-3.
- (c) Ref. 4, p. I-4.
- (d) Ref. 4, p. I-5.
- (e) Ref. 5, Sec. 1.
- (f) Attachment I.
- (g) Ref. 1 (Sec. 5.1.1.1).
- (h) Ref. 6, pp. 3.3-1 to 3.3-6.
- (i) Ref. 6, p. 3.3-6.
- (j) Ref. 5, Sec. 2.
- (k) Ref. 5, Sec. 3.
- (l) Ref. 7, p. 125.
- (m) Ref. 6, p. 3.3-4.

5.2 WP Degraded-Mode Configurations

The criticality evaluations are conducted for two different series of degraded-mode configurations of the WP internals: Intermediate-level degradation configurations and full degradation configurations.

5.2.1 Intermediate-Level Degradation Configurations

Three configurations are analyzed as conservative configurations for intermediate-level degradation. These configurations are discussed below. The waste form is partially degraded but intact. However, the decay of the radioisotopes has been accounted for.

5.2.1.1 "Square" Geometry, Square Lattice Arrangement of Cans

This intermediate-level degradation configuration is shown in Figures 5.2.1.1-1 and 5.2.1.1-2. As depicted in Figure 5.2.1.1-1, the non-degraded cans, containing the Pu-bearing ceramic disks, create a "square" lattice (a 6x6 array missing the top-right-hand corner element) in the bottom segment of the water-filled WP with a pitch equal to a can outer diameter.

Figure 5.2.1.1-2 provides a cross-sectional side view of the configuration considered (the cutting plane is perpendicular to the x axis and passes through the center of the WP). Figure 5.2.1.1-3 shows the cross-section of a typical can containing 20 ceramic disks. The computational model considers some gaps between the disks as well as between the disks and the can.

As shown in Figures 5.2.1.1-1 and 5.2.1.1-2, a layer of water surrounds the WP computational model. This layer of water acts as neutron reflector.

This degradation configuration is considered to be the most conservative one from the nuclear criticality viewpoint. The conservatism is due to the following assumptions:

- (a) the columns of the stacked cans, loaded with the Pu-containing ceramic disks and preserving their intact-mode arrangement, create a maximum concentration of fissile material (the cans touching in the square lattice);
- (b) the cans are surrounded by pure water (neutron moderator) and water has penetrated into the cans through some pinholes; and
- (c) the degradation products (from the canister, spacer tube, and HLW), which could contribute to neutron absorption, are not considered in the model.

5.2.1.2 Pseudo-Cylindrical Segment Geometry, "Square Lattice" Arrangement of Cans

This intermediate-level degradation configuration is shown in Figure 5.2.1.2-1 and the input data for the cans and their contents are from Table 5.1-1. As depicted in Figure 5.2.1.2-1, at this level of degradation, the non-degraded cans, containing the Pu-bearing ceramic disks, create a pseudo-cylindrical segment geometry with "square lattice" arrangement in the bottom segment of the water-filled WP with a vertical pitch equal to a can outer diameter. Water also fills the void space inside the cans through some pinholes. This configuration is modeled by lowering the stack of the horizontal cans in the square lattice arrangement (Sec. 5.2.1.1) in order to settle at the bottom of the WP.

This degradation configuration, representing a more "natural" or "reasonable" configuration than the square lattice configuration, is expected to be less neutronically reactive than the previous case (Sec. 5.2.1.1). The less conservatism is due to the fact that the configuration is more spread than the square lattice (and the non-vertical pitches are longer than their counterparts in the original square lattice) causing more neutron leakage.

08/14/98 15:51:44
Degraded Mode Criticality
Analysis of Plutonium
Dispersed in Ceramic
probid = 08/14/98 15:49:43
basis:
(1.000000, .000000, .000000)
(.000000, 1.000000, .000000)
origin:
(-.60, 1.62, .00)
extent = (134.98, 134.98)

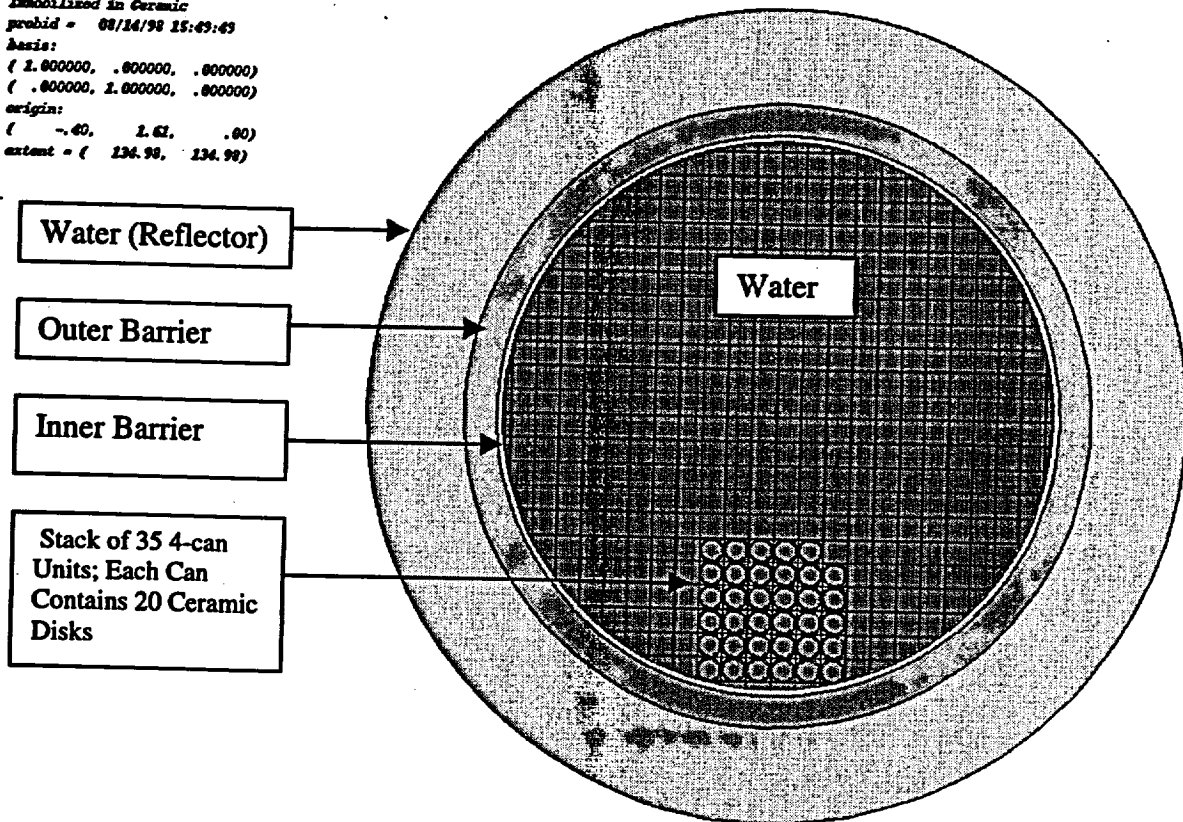

Figure 5.2.1.1-1. A Cross-sectional Front View of a Horizontally Emplaced Waste Package Depicting a Square Lattice Arrangement of Cans in a "Square" Geometry

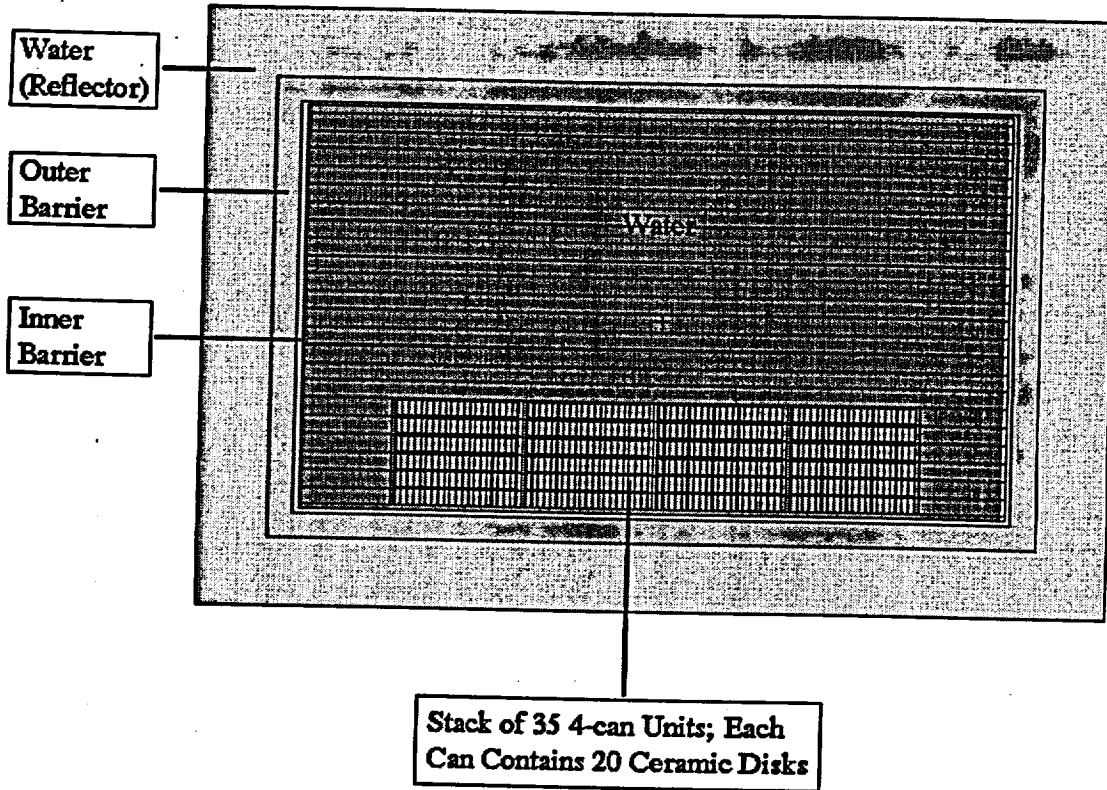

Figure 5.2.1.1-2. A Cross-sectional Side View of a Horizontally Emplaced Waste Package for the Square Lattice Arrangement of Cans in a "Square" Geometry

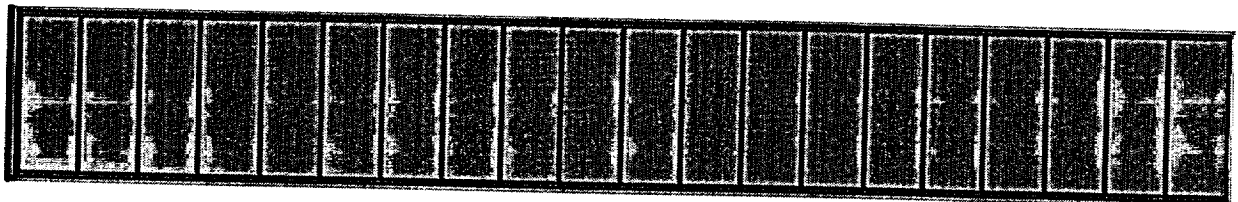

Figure 5.2.1.1-3. A Cross-section of a Can Containing the 20 Ceramic Disks

```

08/16/98 20:35:33
Degraded Mode Criticality
Analysis of Plutonium
Emulsified in Ceramic (wp:01)
probid = 08/16/98 20:33:23
basis:
( 1.000000, .000000, .000000)
( .000000, 1.000000, .000000)
origin:
( -1.36, -1.36, .00)
extent = ( 136.66, 136.66)
    
```

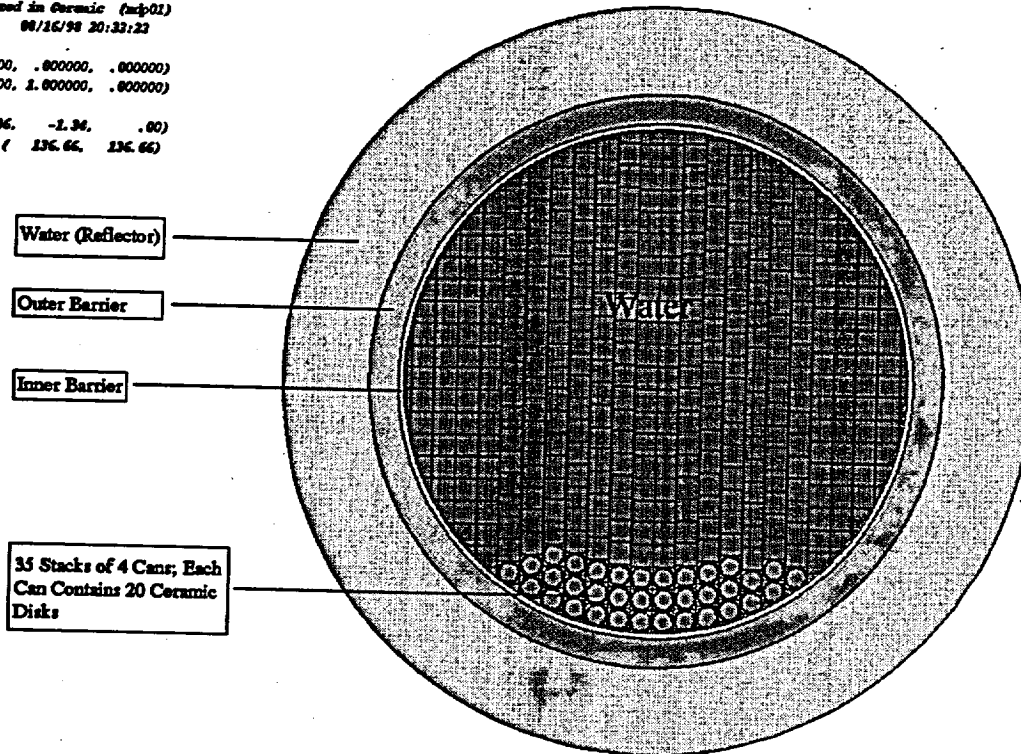

Figure 5.2.1.2-1. A Cross-sectional Front View of a Horizontally Emplaced Waste Package Depicting a "Square Lattice" Arrangement of Cans in a Pseudo-Cylindrical Segment Geometry

5.2.1.3 Pseudo-Cylindrical Segment Geometry, "Square Lattice" Arrangement of Ceramic Disks

A WP intermediate-level degradation configuration similar to that discussed above, but without stainless steel cans is considered in this case. It is assumed that the ceramic disks preserve their intact-mode arrangement (the pitch is equal to the original can diameter). This case is expected to be more reactive than the above case due to the absence of the stainless steel, which is a mild neutron absorber.

5.2.2 Full Degradation Configuration

The fully-degraded mode configuration of the WP, where the WP internals have lost their original intact configurations and compositions, is depicted in Figure 5.2.2-1. The degree of degradation of the WP internals depends on the time at which the condition of the degraded material is considered. In this figure, the bottom segment of the WP contains a mixture of degradation products and non-degraded WP internals, as specified in Ref. 1, Sec. 5.3.1. Water

fills the remaining segment of the WP. The criticality analysis is performed at a time that is 11,500, 30,200, or 30,860 years after the initial breach of the WP. The most abundant elements present in the homogenized mixture from the geochemistry degradation analysis (Ref. 1) are listed in Table 5.2.2-1 along with their corresponding mole fractions. These compositions are given in moles per liter of waste package void volume (3737.9 liters calculated in Ref. 10, spreadsheet masses5.xls) to preserve consistency with the geochemistry calculations of Ref. 1. The data are from Ref. 10, spreadsheet %remain.xls, sheets run2_TOT and run6_TOT. The criticality evaluations were performed for cases where the homogenized mixture of the degradation products and non-degraded WP internals contained different percentages of water by volume. The cases were run with partial loss or total loss (a non-physical case) of the principal neutron absorber Gd.

```
08/16/98 23:37:27
Degraded Mode Criticality
Analysis of Plutonium
Immobilized in Ceramic (skip1)
probid = 08/16/98 23:36:17
basis:
( 1.000000, .000000, .000000)
( .000000, 1.000000, .000000)
origin:
( .00, .00, .00)
output = ( 200.00, 200.00)
```

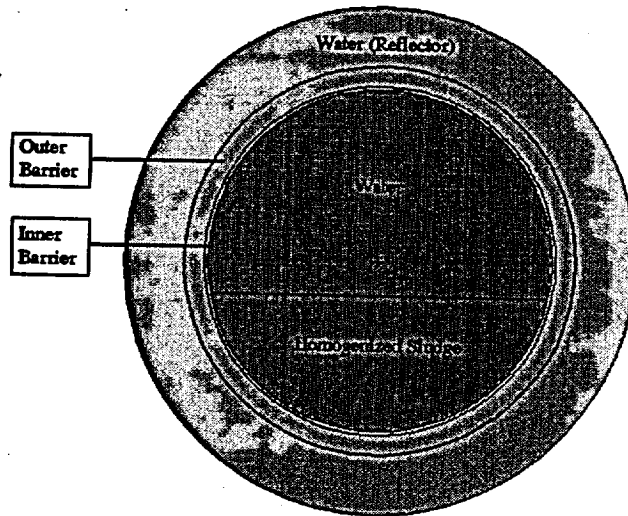

Figure 5.2.2-1. A Cross-sectional Front View of a Horizontally Emplaced Waste Package for the Full Degradation Configuration

Table 5.2.2-1. The Most Abundant Elements or Isotopes Present in the Sludge

Element or Isotope	Moles per Liter of Void Volume ^(a)			
	Before WP is Breached	At 30,200 Years ^(b)	At 30,860 Years ^(b)	At 30,200 Years ^(b)
		1.86 % Total Gd Loss ^{(c) (d)}	13.2 % Total Gd Loss ^{(c) (e)}	No Gd Present (Replaced Gd ₂ O ₃ with Al ₂ O ₃ ^(f))
O-16	61.616	66.097	66.738	66.097
Ti	1.642	1.534	1.642	1.534
U-238	0.479	0.320	0.320	0.320
Pu-239	0.161	0.068 (0.116) ^(g)	0.067 (0.116) ^(g)	0.068
Hf ⁽ⁱ⁾	0.190	0.190	0.190	0.190
Ca	0.986	0.911	0.478	0.911
Gd	0.159 ^(g)	0.156	0.138	0
Al-27	1.750 ^(h)	1.753	1.754	1.909
U-235	0.001	0.094 (0.046) ^(j)	0.095 (0.046) ^(j)	0.094
Fe	12.269	12.072	12.075	12.072
Na-23	7.602	0.033	0.022	0.033
Ni	1.644	1.184	1.369	1.184
Si	15.997	16.032	16.036	16.032
Mn-25	0.818	0.858	0.858	0.858
H	0	8.824	9.446	8.824
C	0.020	0	0	0

- (a) Based on the normalization performed in Ref. 1, p. 24.
- (b) Time after the initial breach of the waste package.
- (c) No more loss in Gd after 11,500 years.
- (d) The values are from the output files of the EQ3/6 code (Ref. 10) and have been rounded to the third decimal place. (See the spreadsheet: gd1-86.xls [sheet: minerals, row 278 and columns AJ-AZ, which have been copied to column DD and rows 29-45] in spreadsheets [Ref. 8].)
- (e) The values are from the output files of the EQ3/6 code (Ref. 10) and have been rounded to the third decimal place. (See the spreadsheet: gd13-2.xls [sheet: minerals & mineral volume, row 278 and columns AJ-AZ, which have been copied to column DC and rows 29-45] in [Ref. 8].)
- (f) The values are from the output files of the EQ3/6 code (Ref. 10) and have been rounded to the third decimal place. (See the spreadsheet: nogd.xls [sheet: No Gd-Al, row 278 and columns AJ-BA, which have been copied to column DC and rows 29-45] in [Ref. 8].)
- (g) This value is zero for the case with no Gd (the right-most column).
- (h) This value is 1.750 + 0.159 = 1.909 for the case with no Gd (the right-most column).
- (i) Hf (Hafnium) is modeled as Zr (Zirconium) in EQ3/6 runs (see Assumption 3.16 on p.10 of Ref. 1).
- (j) Changed to reflect the neutronicly significant isotopic differences between the 11,500 year and 30,200/30860 year cases in Ref. 1, Tables 5.3.2-1 and 5.3.3-1.

6. RESULTS

The results of nuclear criticality evaluations performed for the intermediate-level degradation configurations and full degradation configurations of the WP internals are provided in this section.

6.1 Criticality Evaluation Results for the Intermediate-Level Degradation Configurations

The k_{eff} estimates and their corresponding standard deviations for the intermediate-level degradation configurations in the form of a "square" lattice are provided in Tables 6.1-1 and 6.1-2. As indicated in these tables, the water density changes from 0.01 g/cm³ to 1.0 g/cm³. The intermediate value of 0.1 g/cm³ was used to test for a peak in the range.

Table 6.1-1. k_{eff} Estimates for Intermediate-Level Degradation Configuration: Square Geometry

Case No.	Case Name	Water Density (g/cm ³)	k_{eff}	Standard Deviation	AENCF ^(a) (MeV)
1	dip_i	0.01	0.337	0.00049	0.924
2	dip_x	0.1	0.369	0.00058	0.771
3	dip_c	1.0	0.365	0.00054	0.577

Note: The configuration of the 35 settled tubes inside the WP is a "Square" lattice (a 6x6 square lattice missing the top right-hand corner element).

(a) Average Energy of Neutrons Causing Fission (energy loss to fission divided by weight loss to fission).

Table 6.1-2. k_{eff} Estimates for Intermediate-Level Degradation Configuration: Pseudo Cylindrical Segment Geometry

Case No.	Case Name	Condition of the Stainless Steel Cans	Water Density (g/cm ³)	k_{eff}	Standard Deviation	AENCF ^(c) (MeV)
1	ndp_i	Intact ^(a)	0.01	0.281	0.00047	0.968
2	ndp_x	Intact ^(a)	0.10	0.318	0.00061	0.802
3	ndp_c	Intact ^(a)	1.00	0.336	0.00062	0.543
4	dpnc_i	Degraded ^(b)	0.01	0.297	0.00061	1.058
5	dpnc_x	Degraded ^(b)	0.10	0.332	0.00078	0.880
6	dpnc_c	Degraded ^(b)	1.00	0.367	0.00090	0.577

(a) The configuration of the 35 settled tubes inside the WP is a pseudo-cylindrical segment (three curved layers of tubes with 14, 12, and 9 tubes in the bottom layer, middle layer, and the top layer, respectively).

(b) A configuration similar to (a), but with no stainless steel cans present.

(c) Average Energy of Neutrons Causing Fission.

6.2 Criticality Evaluation Results for the Full Degradation Configurations

The k_{eff} estimates and their corresponding standard deviations for the full degradation configurations are provided in Tables 6.2-1 and 6.2-2. The values in the column labeled "Water Content of the Homogenized Sludge (vol%)" of these tables represent the following ratio:

$$r = \text{vol. of water in the sludge} / (\text{vol. of water in the sludge} + \text{vol. of dry sludge}) * 100\%$$

In the calculations performed in the cells under the cell DN27 of the spreadsheets gd1-86.xls (sheet: minerals), gd13-2.xls (sheet: minerals & mineral volume), and nogd.xls (sheet: No Gd-Al) (Ref. 8), the volume of water in the diluted sludge is calculated as a fraction of the volume of dry sludge:

$$V_{\text{water}} = f V_{\text{dry sludge}}$$

where, $f = r / (1-r)$, in case f is not chosen directly.

Table 6.2-1, where the neutron absorber Gd is partially lost, indicates that the k_{eff} value generally decreases as the water content of the homogenized sludge (homogenized mixture of the degradation products and non-degraded WP internals) increases.

Table 6.2-2, where no Gd is present (a non-physical case), indicates that the k_{eff} value increases as the water content of the homogenized sludge increases.

Table 6.2-1. k_{eff} Estimates for the Full Degradation Configurations with Partial Gd Loss

Case No.	Case Name	Time after the initial breach of the Waste Package (years)	% Gd Loss	Water Content of the Homogenized Sludge (vol%)	k_{eff}	Standard Deviation	AENCF ^(a) (MeV)
1	fdip1r	11500	1.86	0	0.353	0.00073	0.122
2	fdp10r	11500	1.86	9	0.366	0.00074	0.095
3	fdp30r	11500	1.86	23	0.355	0.00080	0.072
4	fdip1	30200	1.86	0	0.322	0.00060	0.120
5	fdip10	30200	1.86	9	0.320	0.00057	0.095
6	fdip30	30200	1.86	23	0.295	0.00053	0.079
7	lgd00r	11500	13.2	0	0.364	0.00071	0.114
8	lgd10r	11500	13.2	10	0.380	0.00059	0.091
9	lgd30r	11500	13.2	30	0.354	0.00063	0.063
10	lgd00w	30860	13.2	0	0.332	0.00069	0.113
11	lgd10w	30860	13.2	10	0.327	0.00067	0.094
12	lgd30w	30860	13.2	30	0.285	0.00050	0.070

(a) Average Energy of Neutrons Causing Fission.

Table 6.2-2. k_{eff} Estimates for the Full Degradation Configurations with no Gd Present

Case No.	Case Name	Water Content of the Homogenized Sludge (vol%)	k_{eff}	Standard Deviation	AENCF ^(a) (MeV)
1	ngdn	0	0.581	0.00112	0.063
2	ngdn30	23	0.824	0.00136	0.028
3	ngdn70	41	0.918	0.00137	0.017
4	ngd60w	60	0.946	0.00117	0.009

Note: The calculations are done at a time that is 30,200 years after the initial breach of the WP.

(a) Average Energy of Neutrons Causing Fission.

7. REFERENCES

- 1 Civilian Radioactive Waste Management System (CRWMS) Management and Operating Contractor (M&O) 1998. *EQ6 Calculations for Chemical Degradation of Pu-Ceramic*

-
- 1 **Waste Package. BBA000000-01717-0210-00018 REV 00. Las Vegas, Nevada. MOL. 19980918.0004.**
 - 2 **CRWMS M&O 1998. *Software Qualification Report for MCNP Version 4B2 A General Monte Carlo N-Particle Transport Code (CSCI: 30033 V4B2LV)*. 30033-2003 REV 01. Las Vegas, Nevada. MOL.19980622.0637.**
 - 3 **Reserved.**
 - 4 **CRWMS M&O 1996. *Material Compositions and Number Densities for Neutronics Calculations (SCPB: N/A)*. BBA000000-01717-0200-00002 REV 00. Las Vegas, Nevada. MOL.19960624.0023.**
 - 5 **Lawrence Livermore National Laboratory 1998. *Plutonium Immobilization Project, Data for Yucca Mountain Total Systems Performance Assessment, Rev. 1*. PIP Milestone Report, Milestone 2.b.b., PIP 98-012. Livermore, California. MOL.19980818.0349.**
 - 6 **U.S. Department of Energy, Office of Civilian Radioactive Waste Management, 1992. *Characteristics of Potential Repository Wastes*. DOE/RW-184-R1, Volume 1. Washington, DC. NNA.19921218.0013.**
 - 7 **CRWMS M&O 1997. Waste Package Materials Selection Analysis. BBA000000-01717-0200-00020 REV 01. Las Vegas, Nevada. MOL.19980324.0242.**
 - 8 **CRWMS M&O 1998. *Criticality Evaluation of Plutonium Disposition Ceramic Waste Form: Degraded Mode*. BBA000000-01717-0210-00014 REV 00. QIC-80 DT-350 Minicartridge Tape. Las Vegas Nevada: Mobasheran, Amir S. MOL.19980909.0272.**
 - 9 **CRWMS M&O 1998. *Criticality Evaluation of Plutonium Disposition Ceramic Waste Form: Degraded Mode*. BBA000000-01717-0210-00014 REV 01. QIC-80 DT-350 Minicartridge Tape. Las Vegas Nevada: Mobasheran, Amir S. MOL.19980918.0205.**
 - 10 **CRWMS M&O 1998. *Electronic Media for BBA000000-01717-0210-00018 REV 00*. QIC-80 D350 Tape. MOL. 19980831.0169.**

8. ATTACHMENTS

Two attachments are referenced in this calculation. Attachment I provides a sketch of the 5-High-Level Waste Canister Waste Package. Attachment II is a listing of the contents of a magnetic tape (Ref. 9), containing MCNP output files. The MCNP output files are the result of running the MCNP code for the six new cases of interest in this revision (criticality evaluations for a time that is 11,500 years after the initial breach of the waste package. The contents of the input data file for each case are echoed in the output file for that case.

Waste Package Operations

Engineering Calculation

Title: Criticality Evaluation of Plutonium Disposition Ceramic Waste Form: Degraded Mode
 Document Identifier: BBA000000-01717-0210-00014 REV 01 Attachment I Page 1 of 1

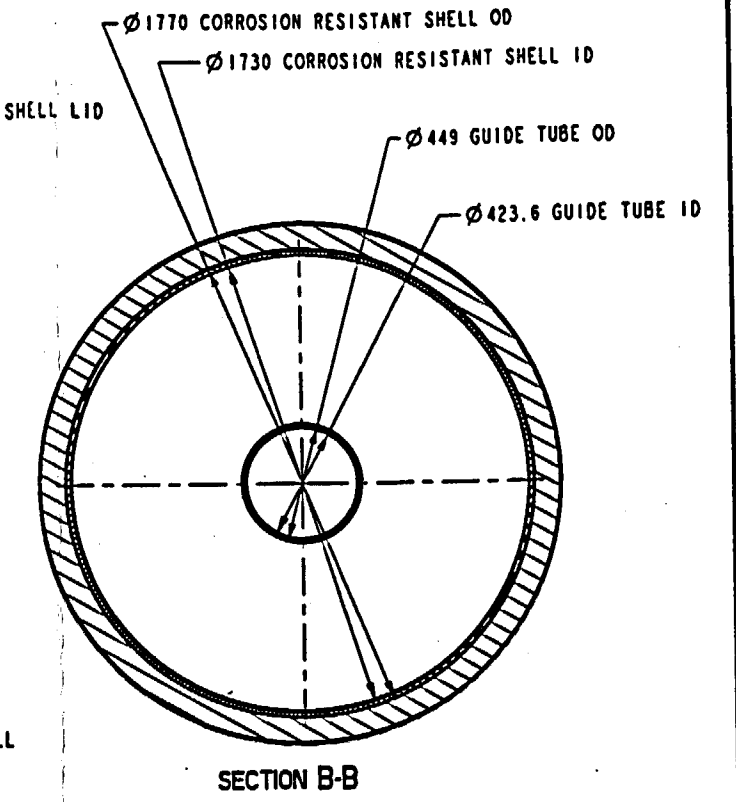
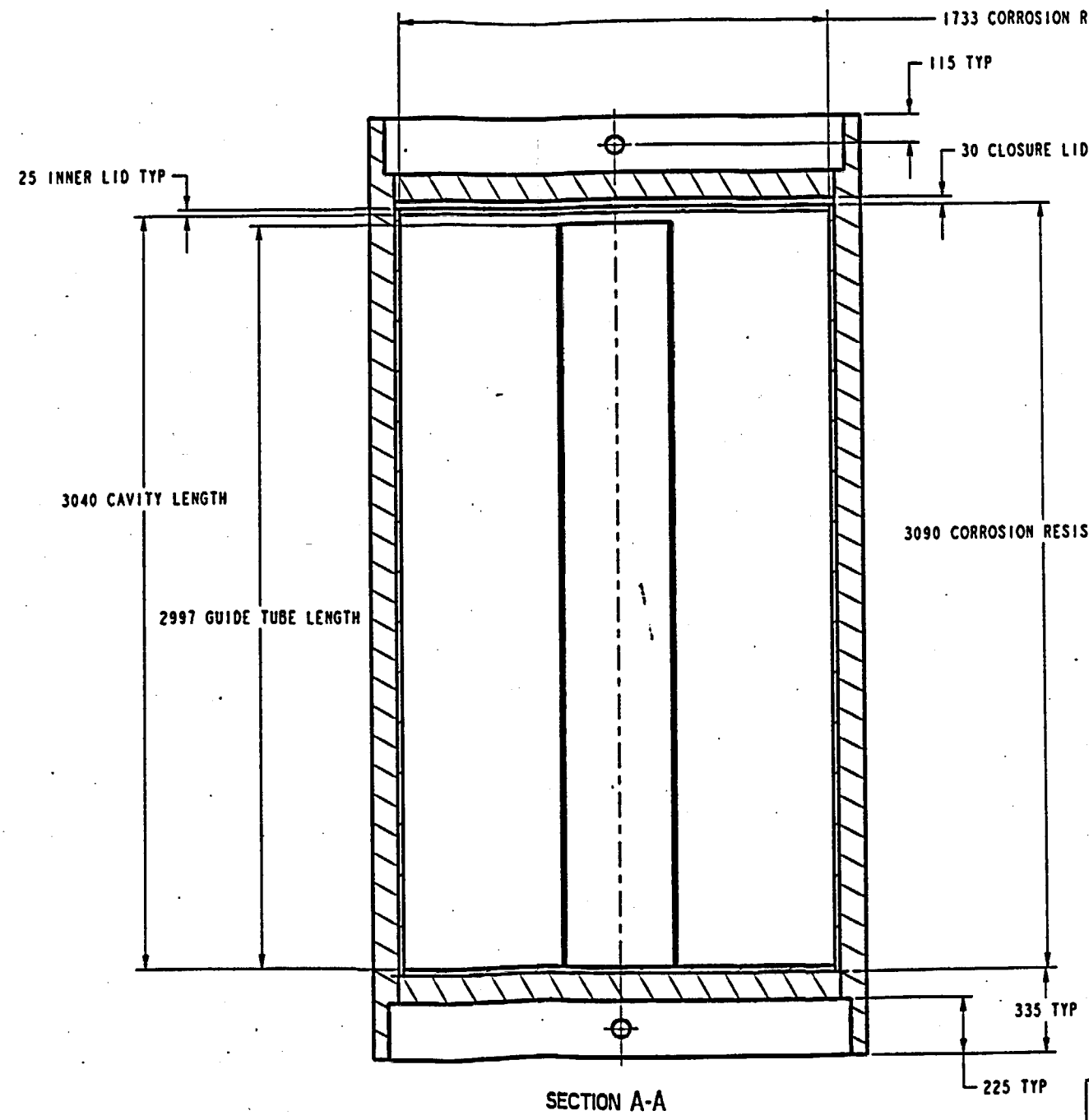
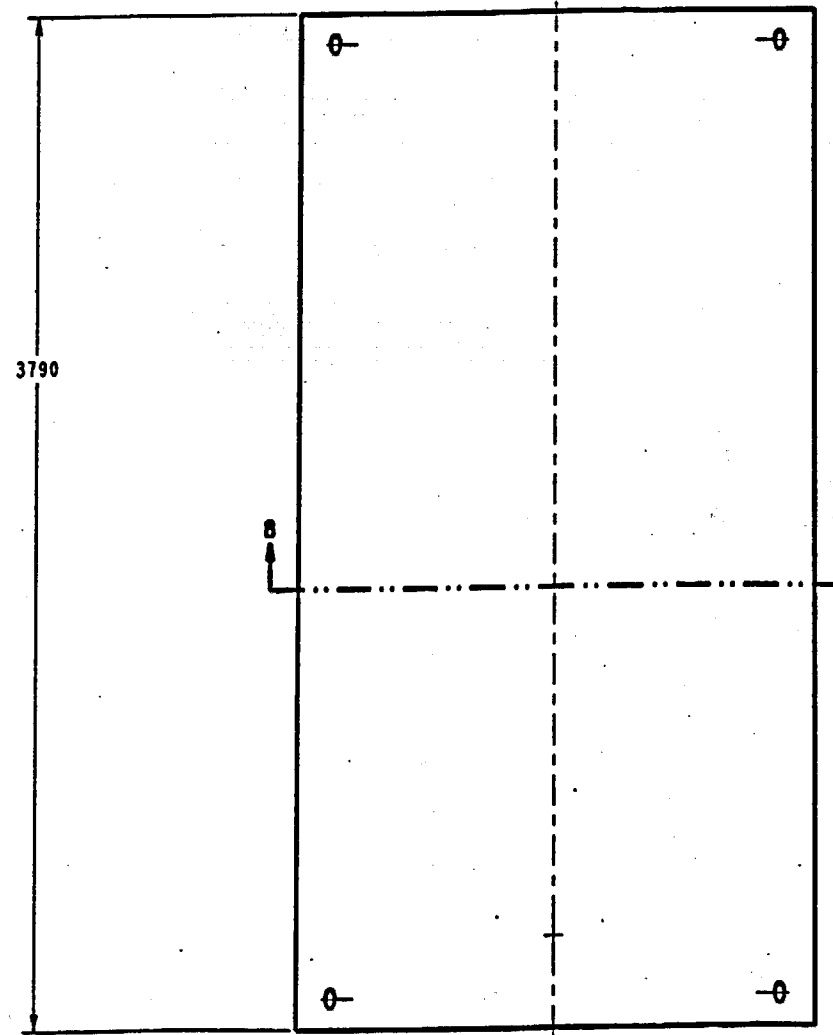
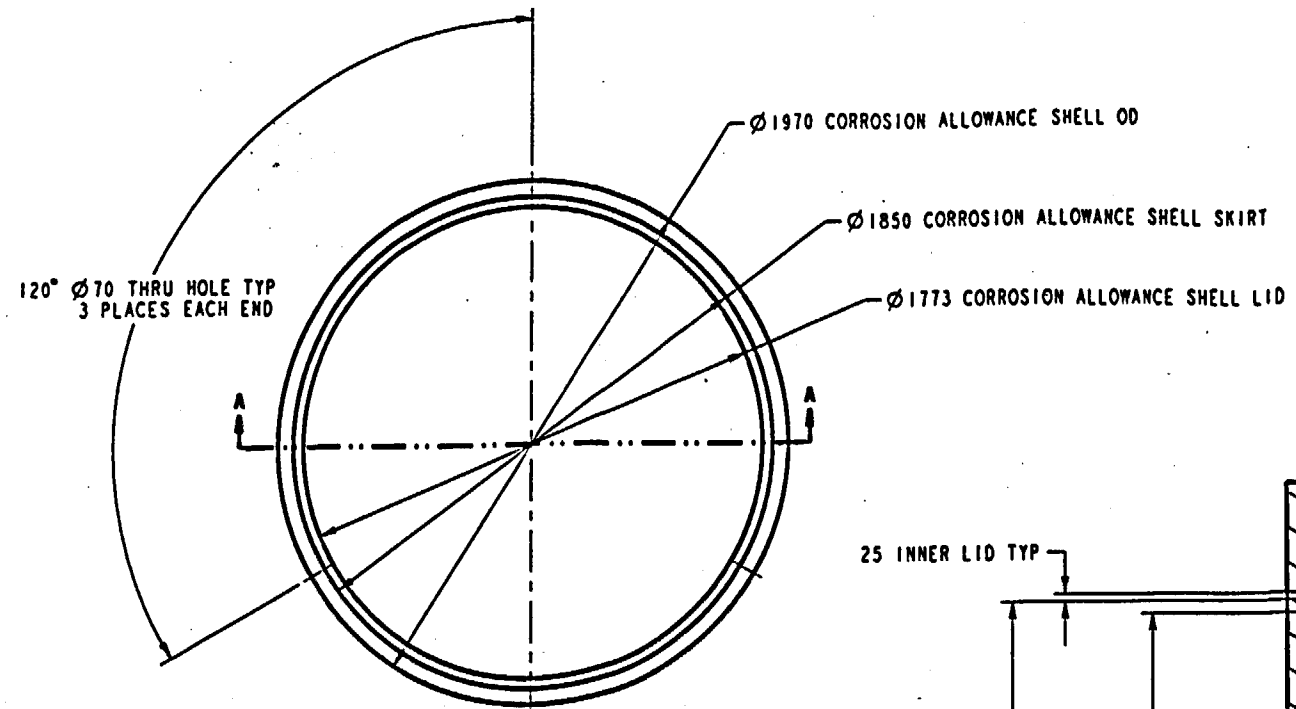

COMPONENT NAME	MATERIAL	THICKNESS	MASS (kg)	QTY REQ
CORROSION ALLOWANCE SHELL	ASTM A 516 GR 70	100	16650	1
CORROSION ALLOWANCE SHELL LID	ASTM A 516 GR 70	110	2132	2
CORROSION RESISTANT SHELL	ALLOY C-22	20	2949	1
CORROSION RESISTANT SHELL LID	ALLOY C-22	25	512	2
GUIDE TUBE	ASTM A 516 GR 70	12.7	410	1

"FOR INFORMATION ONLY"

5-HIGH LEVEL WASTE CANISTER
 WASTE PACKAGE

SKETCH NUMBER:	SK-0080 REV 00
ORIGINATOR:	MICHAEL PLINSKI <i>12 smb</i>
DATE:	04-17-98 <i>4/17/98 4-20-98</i>
FILE:	<i>7-23 4-21-98</i> /users/pro_library/checkout/dhlw_5pk/SK-0080.dwg

DO NOT SCALE FROM SKETCH

UNITS: mm

Attachment II

This attachment provides a hardcopy listing of the contents of a magnetic tape (Ref. 9). As indicated in the table provided below, the magnetic tape contains six MCNP output files. The input files are echoed in their corresponding output files. The output files were transferred from a Hewlett Packard (HP) Series 9000 workstation to a Pentium II Personal Computer (PC) using a file transfer protocol. The HP file sizes differ from the file sizes on the tape due to the difference in the block sizes between the HP and the personal computer. This tape was written using the Colorado Model T1000e External Parallel Port Backup System for personal computers.

The Contents of Magnetic Tape

File name	File Type	Size (K Bytes)	Remarks
fdip1r.o	ASCII	174	MCNP output file
fdp10r.o	ASCII	174	MCNP output file
fdp30r.o	ASCII	174	MCNP output file
lgd00r.o	ASCII	174	MCNP output file
lgd10r.o	ASCII	174	MCNP output file
lgd30r.o	ASCII	174	MCNP output file