

Office of Civilian Radioactive Waste Management



Civilian Radioactive Waste Management System

Preliminary Transportation, Aging and Disposal Canister System Performance Specification

Revision B

DOC ID: WMO-TADCS-0000001

November 2006

U.S. Department of Energy
Office of Civilian Radioactive Waste Management

**PAGE INTENTIONALLY
LEFT BLANK**

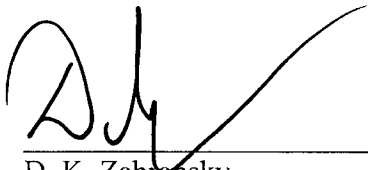
Preparer: 

D. K. Zabransky

12-14-06
Date

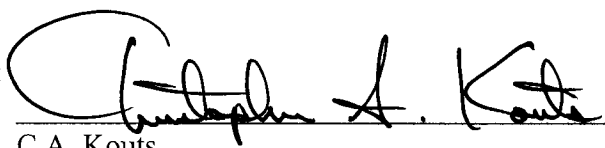
Approval: 

C.A. Kouts
Director
Waste Management Office

12/14/06
Date

REVISION HISTORY

<u>Revision</u>	<u>Change</u>
A	Initial Issue
B	For requirement number (5) and (6) in Section 3.1.1 changed "... or less than 5 years out-of-reactor..." to "... and no less than 5 years out-of-reactor..."

TABLE of CONTENTS

1.0	INTRODUCTION	1
1.1	Purpose	1
1.2	Transportation, Aging and Disposal (TAD) System Description	1
1.2.1	TAD canister	1
1.2.2	Transportation Overpack	2
1.2.3	Transportation Skid	2
1.2.4	Ancillary Equipment	2
1.2.5	Shielded Transfer Cask	2
1.2.6	Aging Overpack	2
1.2.7	Site Transporter	2
1.2.8	Waste Package Overpack	3
1.2.9	Storage Overpack	3
1.3	Definitions	3
1.4	Safety Classification of the Components	4
1.5	Limitations	4
2.0	APPLICABLE DOCUMENTS/REFERENCES	4
2.1	Regulations	4
2.2	DOE Documents	5
2.3	NRC Documents	5
2.4	Codes and Standards	6
2.5	Other References	7
3.0	PERFORMANCE REQUIREMENTS	7
3.1	TAD Canister	7
3.1.1	General	7
3.1.2	Structural	9
3.1.3	Thermal	10
3.1.4	Dose and Shielding	11
3.1.5	Criticality	11
3.1.6	Containment	13
3.1.7	Operations	13
3.1.8	Materials	14
3.2	Transportation Overpack	15
3.2.1	General	15
3.2.2	Structural	16
3.2.3	Thermal	16
3.2.4	Dose and Shielding	16
3.2.5	Criticality	16
3.2.6	Containment	16
3.2.7	Operations	16
3.2.8	Materials	17
3.3	Aging Overpack	17
3.3.1	General	17
3.3.2	Structural	18
3.3.3	Thermal	20

3.3.4	Dose and Shielding	21
3.3.5	Criticality	21
3.3.6	Containment	21
3.3.7	Operations	21
3.3.8	Materials	21
4.0	GLOSSARY	21

Attachment A Seismic Data for Yucca Mountain Geologic Repository Operations Area

Attachment B Postclosure Criticality Loading Curves

Attachment C Integral Lifting Ring

Attachment D Aging Overpack Details

ACRONYMS

ALARA	as low as is reasonably achievable
BSC	Bechtel SAIC Company, LLC
BWR	boiling water reactor
CFR	Code of Federal Regulation
CSNF	commercial spent nuclear fuel
DCRA	disposal control rod assembly
DOE	U.S. Department of Energy
GROA	geologic repository operations area
HLW	high-level radioactive waste
HVAC	heating, ventilation and air-conditioning
ISFSI	independent spent fuel storage installation
ITS	important to safety
MTHM	metric tons of heavy metal
MTIHM	metric tons of initial heavy metal
MTU	metric tons of uranium
NRC	U.S. Nuclear Regulatory Commission
NWPA	Nuclear Waste Policy Act
OCRWM	Office of Civilian Radioactive Waste Management
PWR	pressurized water reactor
SNF	spent nuclear fuel
SSC	structures, systems and components
STC	shielded transfer cask
TAD	transportation, aging and disposal
TEDE	total effective dose equivalent
USL	upper subcritical limit
YMP	Yucca Mountain Project

**PAGE INTENTIONALLY
LEFT BLANK**

ABBREVIATIONS

° C	degrees Centigrade
° F	degrees Fahrenheit
BTU	International Table British thermal unit
BTU/hr-ft ²	British thermal unit per hour-square foot
Bq	becquerel
cm	centimeter
cm ²	square centimeter
dpm	disintegrations per minute
ft	feet
ft/s	feet per second
g	acceleration due to gravity
g/cm ²	grams per square centimeter
GWd	gigawatt-day
h or hr	hour
in.	inches
k _{eff}	effective neutron multiplication factor
kg	kilogram
km	kilometer
km/hr	kilometer/hour
kPa	kilopascal
kW	kilowatt
kW/m ²	kilowatt per square meter
lb	pound(s) (weight; unless otherwise specified)
lb/ft ²	pounds per square foot
lb/in ²	pounds per square inch
lb/in ² /sec	pounds per square inch per second
m	meter
m/s	meter per second
m ²	square meter(s)
mho	Conductance in mho being the reciprocal of resistance in ohms
mm	millimeter
MPa	megapascal
mph	miles per hour

mrem	milli roentgen equivalent man
MT	metric tons
pH	potential of hydrogen
ppm	parts per million
psi, lb/in ²	pounds per square inch
s or sec	second
ton	short ton (2,000 lb weight)
torr	pressure that causes the Hg column to rise 1 millimeter
yr	year

1.0 INTRODUCTION

1.1 Purpose

This document provides specifications for selected system components of the Transportation, Aging and Disposal (TAD) canister-based system. A list of system specified components and ancillary components are included in Section 1.2.

The TAD canister, in conjunction with specialized overpacks will accomplish a number of functions in the management and disposal of spent nuclear fuel. Some of these functions will be accomplished at purchaser sites where commercial spent nuclear fuel (CSNF) is stored, and some will be performed within the Office of Civilian Radioactive Waste Management (OCRWM) transportation and disposal system. This document contains only those requirements unique to applications within Department of Energy's (DOE's) system. DOE recognizes that TAD canisters may have to perform similar functions at purchaser sites. Requirements to meet reactor functions, such as on-site dry storage, handling, and loading for transportation, are expected to be similar to commercially available canister-based systems.

This document is intended to be referenced in the license application for the Monitored Geologic Repository (MGR). As such, the requirements cited herein are needed for TAD system use in OCRWM's disposal system. This document contains specifications for the TAD canister, transportation overpack and aging overpack. The remaining components and equipment that are unique to the OCRWM system or for similar purchaser applications will be supplied by others.

1.2 Transportation, Aging and Disposal (TAD) System Description

A TAD system consists of a canister, together with other equipment, that allows for management of commercial spent nuclear fuel.

1.2.1 TAD canister

The TAD canister is loaded with commercial spent nuclear fuel (CSNF) and sealed at purchaser sites (e.g., reactors). It may be used for storage for a period of time at purchaser sites; for this purpose it must be approved contents for a storage system certified under title 10 CFR part 72. It may be delivered to DOE for transportation to the geologic repository operations area (GROA), for which it would be listed as approved contents for packaging, including the transportation overpack, certified under title 10 CFR part 71. At the GROA, a TAD canister may also be handled using a shielded transfer cask or aged in an aging overpack; and shall be disposed of in a waste package. All three of these functions will be covered by the repository license granted under title 10 CFR part 63.

1.2.2 Transportation Overpack

The transportation overpack is an overpack certified under title 10 CFR part 71 as a packaging component used to enclose TAD canisters for transportation. The transportation overpack: protects the TAD canister during normal conditions of transport and design basis accidents; dissipates decay heat from the contained CSNF; and, protects workers and the public from radiation.

1.2.3 Transportation Skid

The transportation skid is the means of handling assembled transportation packages at various sites and during inter-modal transfers. The skid provides a standardized means of securing the loaded transportation overpack to any OCRWM rail car conveyance.

After completion of necessary rail car design, the transportation skid performance and design specifications will be prepared.

1.2.4 Ancillary Equipment

Ancillary equipment is any general or site specific equipment, not specifically described within this document, required to operate and handle TAD system components in accordance with their certificates of compliance and other regulatory or operational requirements. Ancillary equipment to be used at the repository will be provided by others. Any ancillary equipment needed for use at purchaser sites is expected to be similar to commercially available equipment in common usage.

1.2.5 Shielded Transfer Cask

The shielded transfer cask (STC) is used to transport a loaded TAD canister among the various surface facilities at the GROA prior to loading into an aging overpack or waste package. The STC protects the TAD canister from damage, protects workers from radiation and allows for proper heat dissipation. The STC for use at the repository will be provided by others. STC to be used at purchaser sites are expected to be similar to commercially available equipment commonly used.

1.2.6 Aging Overpack

Aging overpacks are used to safely contain a loaded TAD canister on the aging pad until repository emplacement thermal limits are met. The aging overpack protects the TAD canisters from damage, dissipates decay heat and protects workers from radiation.

1.2.7 Site Transporter

The site transporter is a vehicle to be used for transporting loaded and unloaded STCs and aging overpacks at the GROA. The transporter will also provide support for STCs and aging overpacks during loading and unloading operations. The site transporter will be provided by others. A site transporter is expected to be required to perform analogous functions

at purchaser sites. Any site transporter that is part of a site specific independent spent fuel storage installation (ISFSI) system is expected to be similar to commercially available equipment in common usage.

1.2.8 Waste Package Overpack

The waste package overpack is the disposal container that the TAD canister will be sealed inside prior to final emplacement in the drift.

1.2.9 Storage Overpack

The storage overpack provides functions analogous to the aging overpack at purchaser sites. Storage overpacks which are part of a purchaser site specific ISFSI will be designed to meet the requirements of title 10 CFR part 72. Storage overpacks used at purchaser sites as part of a site specific ISFSI are expected to be similar to commercially available equipment in common usage.

1.3 Definitions

Accident- An undesirable event; especially one that could potentially do damage or harm to a cask or its contents.

Approved Contents- Used in the context of this performance specification, the term “approved contents” means one of the following:

Transportation Overpack: The contents of Type B packaging as discussed in Section 1.3.3 “Package Description” of *The Standard Review Plan for Transportation Packages for Spent Nuclear Fuel* (NUREG-1617) and listed in section 5b “Contents of Packaging” of Certificates of Compliance issued under 10 CFR part 71.

Storage Overpack: The materials to be stored as discussed in Section 4.4.1 of *Standard Review Plan for Spent Fuel Dry Storage Facilities* (NUREG-1567) and listed in Section 6 “Approved Contents” of Certificates of Compliance issued under 10 CFR part 72.

Normal- A term used to define expected radioactive wastes, operations and/or processes.

Off-normal- A term used to define any combination of radioactive waste, operations or processes that are not expected during normal activities; usually associated with damaged or failed materials, equipment or processes.

Purchaser- Any person, other than a Federal agency, who is licensed by the Nuclear Regulatory Commission to use a utilization or production facility under the authority of sections 103 or 104 of the Atomic Energy Act of 1954 (42 U.S.C. 2133, 2134) or who has title to spent nuclear fuel or high-level radioactive waste and who has executed a contract for disposal of spent nuclear fuel and/or high-level radioactive waste with DOE.

1.4 Safety Classification of the Components

Safety classification of the components in this specification has not been assigned. However; the TAD canister, the transportation overpack, and the aging overpack covered by this specification are expected to be Important to Safety (ITS).

1.5 Limitations

No portion of this specification shall be interpreted such that it suggests, implies or intimates that the vendor is responsible for showing compliance with 10 CFR part 63, *Disposal of High-Level Radioactive Wastes in a Geologic Repository at Yucca Mountain, Nevada*. That responsibility remains the sole purview of the Department of Energy.

Those conditions unique to the operations at the GROA are included in this performance specification.

2.0 APPLICABLE DOCUMENTS/REFERENCES

2.1 Regulations

10 CFR part 19- 2006 Energy: *Notices, Instructions and Reports to Workers: Inspection and Investigations*.

10 CFR part 20- 2006 Energy: *Standards for Protection Against Radiation*.

10 CFR part 21- 2006 Energy: *Reporting of Defects and Noncompliance*.

10 CFR part 26- 2006 Energy: *Fitness for Duty Programs*.

10 CFR part 50- 2006 Energy: *Domestic Licensing of Production and Utilization Facilities*.

10 CFR part 63- 2006 Energy: *Disposal of High-Level Radioactive Wastes in a Geologic Repository at Yucca Mountain, Nevada*.

10 CFR part 71- 2006 Energy: *Packaging and Transportation of Radioactive Material*.

10 CFR part 72- 2006 Energy: *Licensing Requirements for the Independent Storage of Spent Nuclear Fuel, High-Level Radioactive Waste and Reactor-Related Greater than Class C Waste*.

10 CFR part 73- 2006 Energy: *Physical Protection of Plants and Materials*.

10 CFR part 74- 2006 Energy: *Material Control and Accounting of Special Nuclear Material*.

10 CFR part 140- 2006 Energy: *Financial Protection Requirements and Indemnity Agreements.*

10 CFR part 835- 2006 Energy: *Occupational Radiation Protection.*

10 CFR part 961- 2006 Energy: *Standard Contract for Disposal of Spent Nuclear Fuel and/or High-Level Radioactive Waste.*

40 CFR part 261- 2005 *Protection of Environment: Identification and Listing of Hazardous Waste.*

49 CFR part 173- 2005 *Transportation: Shippers--General Requirements for Shipments and Packagings.*

66FR 55732- *Disposal of High-Level Radioactive Wastes in a Proposed Geologic Repository at Yucca Mountain, NV, Final Rule.* 10 CFR parts 2, 19, 20, 21, 30, 40, 51, 60, 61, 63, 70, 72, 73 and 75.

Nuclear Waste Policy Act of 1982. 42 U.S.C. 10101 et seq.

Regulatory Guide 1.23, Rev. 0, 1972; *Onsite Meteorological Programs;* Washington, D.C.: U.S. Atomic Energy Commission.

Regulatory Guide 1.76, Rev. 0, 1974; *Design Basis Tornado for Nuclear Power Plants;* Washington, D.C.: U.S. Atomic Energy Commission.

Resource Conservation and Recovery Act of 1976. 42 U.S.C. 6901 et seq.

2.2 DOE Documents

DOE O 450.1-Change 2; 2005; *Environmental Protection Program;* Washington, D.C.: U.S. Department of Energy.

DOE-STD-1090-2004. 2004. *Hoisting and Rigging (Formerly Hoisting and Rigging Manual).* Washington, D.C.: U.S. Department of Energy.

DOE O 435.1. 1999. *Radioactive Waste Management.* Washington, D.C.: U.S. Department of Energy.

2.3 NRC Documents

NUREG-1567, *Standard Review Plan for Spent Fuel Dry Storage Facilities*

NUREG-1536, *Standard Review Plan for Dry Cask Storage Systems*

NUREG-0612, *Control of Heavy Loads at Nuclear Power Plants*

NUREG-0800, *Standard Review Plan for the Review of Safety Analysis Reports for Nuclear Power Plants*

NUREG/CR-4461, *Tornado Climatology of the Contiguous United States*

NUREG-1804, *Yucca Mountain Review Plan*

2.4 Codes and Standards

AAR (Association of American Railroads) 1993. *Manual of Standards and Recommended Practices, Section C – Part II, Specifications for Design, Fabrication and Construction of Freight Cars M-1001, Volumes I and II Standards*. Washington, D.C.: Association of American Railroads. TIC: 10188.

AAR 2004. *Manual of Standards and Recommended Practices*. Washington, D.C.: Association of American Railroads. TIC: 256289.

AASHTO (American Association of State Highway and Transportation Officials) 2004. *A Policy on Geometric Design of Highways and Streets*. 5th Edition. Washington, D.C.: American Association of State Highway and Transportation Officials. TIC: 257443.

ANSI/ANS-57.7-1988. *American National Standard Design Criteria for an Independent Spent Fuel Storage Installation (Water Pool Type)*. Revision of ANSI/ANS 57.7-1981. La Grange Park, Illinois: American Nuclear Society. TIC: 238870.

ANSI N14.5-97. 1998. *American National Standard for Radioactive Materials - Leakage Tests on Packages for Shipment*. New York, New York: American National Standards Institute. TIC: 247029.

ASCE 7-98. 2000. *Minimum Design Loads for Buildings and Other Structures*. Revision of ANSI/ASCE 7-95. Reston, Virginia: American Society of Civil Engineers. TIC: 247427.

ASME (American Society of Mechanical Engineers) 2004. *2004 ASME Boiler and Pressure Vessel Code*. 2004 Edition. New York, New York: American Society of Mechanical Engineers. TIC: 256479.

ASTM A-276-06. 2006. *Standard Specification for Stainless Steel Bars and Shapes*. West Conshohocken, PA: ASTM International. TIC: 258258

ASTM B 932-04. 2004. *Standard Specification for Low-Carbon Nickel-Chromium-Molybdenum-Gadolinium Alloy Plate, Sheet and Strip*. West Conshohocken, Pennsylvania: American Society for Testing and Materials. TIC: 255846.

ISO 11611984/Cor.1:1990(E). 1990. *Series 1 Freight Containers - Corner Fittings - Specification (including Technical Corrigendum 1), 4th Edition*. Geneva, Switzerland: International Organization for Standardization. TIC: 258256; 258247.

SEI/ASCE 7-02. 2003. *Minimum Design Loads for Buildings and Other Structures*. Reston, Virginia: American Society of Civil Engineers. TIC: 255517.

IEEE/ASTM SI 10-1997. 1997. *Standard for Use of the International System of Units (SI): The Modern Metric System*. New York, New York: Institute of Electrical and Electronics Engineers.

2.5 Other References

Preliminary Transportation, Aging and Disposal Canister System Performance Specification Requirements Rationale; DOC ID: WMO-TADCS-RR-000001
Washington, D.C.: U.S. Department of Energy.

3.0 PERFORMANCE REQUIREMENTS

For the purposes of this specification, the following English unit designations and conventions are intended:

lb. = pound weight not pound mass

ton = short ton (2,000 lb weight)

3.1 TAD Canister

When necessary, the following TAD system components shall work in conjunction with the TAD canister to meet objectives of this performance specification:

- Transportation Overpack (Section 3.2)
- Aging Overpack (Section 3.3)
- Ancillary Equipment (Not Included in this Specification)
- Shielded Transfer Cask (Not Included in this Specification)
- Site Transporter (Not Included in this Specification)

3.1.1 General

This section applies to the TAD canister, which will be part of a Nuclear Regulatory Commission (NRC) certified system, approved for confining CSNF during storage, transportation, aging and disposal. The TAD canister includes a canister shell, lid(s) and other required components (e.g., basket for holding fuel assemblies, thermal shunts and neutron absorbers, etc.) needed to perform its functions.

- (1) The TAD canister shall conform to the dimensional envelope (e.g., tolerance stack-up, thermal expansion) based on a right-circular cylinder with a length of $212.0 \text{ in.} \left(\begin{array}{c} +0.0 \text{ in.} \\ -0.5 \text{ in.} \end{array} \right)$ and a diameter of $66.5 \text{ in.} \left(\begin{array}{c} +0.0 \text{ in.} \\ -0.5 \text{ in.} \end{array} \right)$; as shown in Attachment C sketch.

- (2) The TAD canister maximum loaded weight shall be 54.25 tons.
- (3) The capacity of the TAD canister shall be either 21 pressurized water reactor (PWR) spent fuel assemblies or 44 boiling water reactor (BWR) spent fuel assemblies.
- (4) The loaded and closed TAD canister shall be capable of being reopened while submerged in an unborated pool.
- (5) A TAD canister for PWR assemblies shall be limited to accepting CSNF with characteristics less than 5% initial enrichment, 80 GWd/MTU burn up and no less than 5 years out-of-reactor cooling time.
- (6) A TAD canister for BWR assemblies shall be limited to accepting CSNF with characteristics less than 5% initial enrichment, 75 GWd/MTU burnup and no less than 5 years out-of-reactor cooling time.
- (7) A TAD canister shall be capable of being loaded with CSNF from one or more facilities that are licensed by the NRC and hold one or more contracts with the DOE for disposal of CSNF.
- (8) All external edges of the TAD canister shall have a minimum radius of curvature of 0.25 in.
- (9) To the extent practicable, projections or protuberances from reasonably smooth adjacent surfaces shall be avoided or smoothly blended into the adjacent smooth surfaces.
- (10) The TAD canister shall be designed to store vendor defined design basis CSNF at a purchaser site in accordance with 10 CFR part 72.
- (11) A TAD canister shall be designed to transport vendor defined design basis CSNF to the GROA in a horizontal configuration.
- (12) A TAD canister shall be designed to dispose of vendor defined design basis CSNF in a waste package in a horizontal configuration.
- (13) A TAD canister shall be designed to be handled at the GROA loaded with vendor defined design basis CSNF in a vertical configuration.
- (14) A TAD canister shall be designed to age vendor defined design basis CSNF in a vertical configuration.
- (15) Prior to emplacement for disposal, the service lifetime of the TAD canister shall be a minimum of 100 years without maintenance.
- (16) The service lifetime environmental conditions shall be an unprotected "harsh marine environment."

3.1.2 Structural

- (1) The TAD canister shall be required to meet temperature and leak tight standards for 2,000-year and 10,000-year design basis seismic events. The seismic return vertical and horizontal accelerations are defined in Attachment A of this performance specification.
- a. Following a 2,000-year seismic return period event, a TAD canister in an aging overpack shall maintain a maximum leakage rate of 1.5×10^{-12} fraction of canister free volume per second (normal) and maximum cladding temperature of 752° F (normal).
 - b. Following a 10,000-year seismic return period event, a TAD canister in an aging overpack shall maintain a maximum leakage rate of 1.5×10^{-12} fraction of canister free volume per second (normal) and cladding temperature limit of 1,058° F (off-normal) following a seismic event defined by the 10,000-year seismic return period.
- (2) A TAD canister in an aging overpack shall maintain a maximum leakage rate of 1.5×10^{-12} fraction of canister free volume per second (normal) and cladding temperature limits (see inset) during and following exposure to the environmental conditions listed below.

For 2a - 2e below, the cladding temperature limits are 752° F and 1,058° F for “normal” and “off-normal” limits, respectively.

- a. These environmental conditions are not cumulative but occur independently:
 - Outdoor average daily temperature range of 2° F to 116° F with insolation as specified in 10 CFR part 71 (normal)
 - An extreme wind gust of 90 mph for 3-sec (normal)
 - Maximum tornado wind speed of 189 mph with a corresponding pressure drop of 0.81 lb/in² and a rate of pressure drop of 0.30 lb/in²/sec (off-normal). The spectrum of missiles from the maximum tornado is provided in Table 3.1-1 (off-normal):

Table 3.1-1 Spectrum of Missiles

Missile	Mass (lb)	Dimensions (ft)	Hor. Vel. (ft/s)
Wood Plank	114.6	0.301 × 0.948 × 12	190.2
6" Schedule 40 pipe	286.6	0.551D × 15.02	32.8
1 in. steel rod	8.8	0.0833D × 3	26.3
Utility Pole	1,124	1.125D × 35.04	85.3
12" Schedule 40 pipe	749.6	1.05D × 15.02	23.0
Automobile	3,990	16.4 × 6.6 × 4.27	134.5

- b. Annual precipitation of 20 inches/year (normal). The spectrum of rainfall is provided in Table 3.1-2 (normal):

Table 3.1-2 Spectrum of Rainfall

Parameter and Frequency	Nominal Estimate	Upper Bound 90% Confidence Interval*
Maximum 24-hr precipitation (50-year return period)	2.79 in./day	3.30 in./day
Maximum 24-hr precipitation (100-year return period)	3.23 in./day	3.84 in./day
Maximum 24-hr precipitation (500-year return period)	4.37 in./day	5.25 in./day
Precipitation 1-hr intensity (50-year return period)	1.35 in./hr	1.72 in./hr
Precipitation 1-hr intensity (100-year return period)	1.68 in./hr	2.15 in./hr

*Use the values for upper bound 90% confidence interval.

- c. Maximum daily snowfall of 6.0 in. (normal)
 - d. Maximum monthly snowfall of 6.6 in. (normal)
 - e. A lightning strike with a peak current of 250 kiloamps over a period of 260 microseconds and continuous current of 2 kiloamps for 2 seconds (off-normal).
- (3) The TAD canister shall have a flat bottom.

3.1.3 Thermal

- (1) For normal operations, CSNF cladding temperature in TAD canisters shall not exceed 752° F. Normal operations include storage at purchaser sites, transportation from purchasers to the GROA and handling at the GROA (e.g., aging, storage, onsite transfer, etc).
- (2) TAD canister cooling features and mechanisms shall be passive.
- (3) For normal operations in the repository emplacement drifts, the CSNF cladding temperature contained in a TAD canister shall not exceed 662° F. This includes both preclosure and postclosure time periods.

For purposes of demonstrating the TAD canister meets this requirement, Table 3.1-3 specifies boundary conditions and assumptions to be used to calculate fuel rod temperatures. This table is valid for total TAD canister thermal power values ranging from 11.8 kW to 25 kW.

Table 3.1-3 Boundary Conditions for Calculating Fuel Rod Temperatures

For a Uniform Radial Surface Temperature of:	Minimum Peak Heat Flux Through Surface:	Minimum Average Heat Flux Through Radial Surface:
525° F	0.78 kW/m ²	0.42 kW/m ²
450° F	1.19 kW/m ²	0.64 kW/m ²
358° F	1.65 kW/m ²	0.89 kW/m ²

NOTE: This is not the sole measure that cladding temperature limits are satisfied after emplacement. It is simply a measure of the TAD canister thermal resistance. This indicates that a TAD canister will be thermally compatible with a waste package for drift emplacement after sufficient cooling.

3.1.4 Dose and Shielding

- (1) For GROA operations, the combined neutron and gamma integrated average dose rate over the top surface of a loaded TAD canister shall not exceed 800 mrem/hr on contact.
- (2) For GROA operations, the combined contact neutron and gamma maximum dose rate at any point on the top surface of the TAD canister shall not exceed 1,000 mrem/hr.
- (3) The TAD canister shall be designed such that accessible external surfaces contamination shall be removable to:
 - a. 1,000 dpm/100 cm² - beta-gamma with a wipe efficiency of 0.1.
 - b. 20 dpm/100 cm² - alpha with a wipe efficiency of 0.1

3.1.5 Criticality

- (1) Preclosure Criticality - The maximum calculated effective neutron multiplication factor (k_{eff})¹ (assuming same burnup credit currently given under 10 CFR 71, which requires demonstrating criticality safety under fully flooded conditions with unborated water) for a TAD canister containing the most reactive CSNF for which the design is approved shall not exceed the upper subcritical limit (USL)² for three archetypical preclosure proxy configurations³.

¹ The maximum k_{eff} for a configuration is the value at the upper limit of a two-sided 95% confidence interval.

² The USL is a value of k_{eff} that accounts for biases and uncertainties for the configurations and includes an administrative margin to provide added assurance of subcriticality.

³ The *Criticality Input to Canister Based System Performance Specification for Disposal* provides a set of considerations for determining the proxy configurations based upon analyses of different, but similar, waste package designs. A summary of the three proxy configurations are:

- (1) Nominal fully loaded TAD configurations that are open and fully flooded in the Wet Handling Facility pool with no soluble neutron absorber present in the pool water;
- (2) Off-normal TAD configurations where a fuel assembly, normal or deformed, are lying across an open, fully loaded, TAD in the Wet Handling Facility pool with no soluble neutron absorber present in the pool water;
- (3) Off-normal configurations where the TAD shell, TAD internals and CSNF assemblies are reconfigured in accordance with a 50g impact in the orientation that would result in the greatest force transfer to the TAD and its contents while inside the transfer cask and in the Wet Handling Facility pool (i.e., the TAD is fully flooded with no soluble neutron absorber present in the pool water).

- (2) Postclosure Criticality control shall be maintained by employing either the items in (a) or the analysis in (b), as follows:
- a. Include the following features in the TAD internals:
 1. Neutron absorber plates or tubes made from borated stainless steel produced by powder metallurgy and meeting ASTM A887-89 Grade “A” alloys.
 2. Minimum thickness of neutron absorber plates shall be 0.433 inches. Maximum and nominal thickness can be based on structural requirements.
 3. The neutron absorber plate shall have a boron content of 1.1 wt % to 1.2 wt %, a range that falls within the specification for 304B4 UNS S30464 as described in ASTM A887-89.
 4. Neutron absorber plates or tubes must extend the full axial length (+0”/-1/2”) of the canister internals at room temperature.
 5. Neutron absorber plates or tubes must cover all four longitudinal sides of each fuel assembly.
 6. TAD canister designs for PWR fuel assemblies shall accommodate assemblies loaded with a disposal control rod assembly (DCRA⁴). A DCRA is intended for acceptance of PWR CSNF with characteristics outside limits set in the postclosure criticality loading curves. Examples (i.e., illustrative purposes only) of postclosure criticality loading curves are shown in Attachment B of this performance specification. Final postclosure criticality loading curves that represent a PWR TAD canister with features described in items 1 through 5 of this subsection will be provided at a later data.
 - b. Perform analyses of TAD systems to ensure the maximum calculated effective neutron multiplication factor (k_{eff})⁵ for a TAD containing the most reactive CSNF for which the design is approved shall not exceed the critical limit⁶ for four postclosure archetypical proxy configurations.^{7,8}

⁴ DCRA is similar to control rod assemblies, reactivity control assemblies, reactivity control cluster assemblies or burnable poison rod assemblies placed in fuel assemblies during irradiation in reactors. A primary difference is extra thick zircaloy cladding, absorber materials that extend beyond the active fuel length and spiders that hold rods have thick zircaloy or titanium locking mechanism(s).

⁵ The maximum k_{eff} for a configuration is the value at the upper limit of a two-sided 95% confidence interval.

⁶ The critical limit is the value of k_{eff} at which a configuration is considered potentially critical including biases and uncertainties (BSC 2004, Section 6.3.1).

⁷ The *Criticality Input to Canister Based System Performance Specification for Disposal* (BSC 2006, Section 3.1) provides a set of considerations for determining the proxy configurations based upon analyses of different, but similar, waste package designs. A list of the four proxy configuration cases are:

- a. Nominal case, basket assembly degraded, CSNF intact.
- b. Seismic case-I, basket assembly intact, CSNF degraded.
- c. Seismic case-II, basket assembly degraded, CSNF degraded.
- d. Igneous intrusion case, basket assembly degraded, CSNF degraded, waste package and TAD structural deformation.

3.1.6 Containment

- (1) The TAD canister shall be designed to facilitate helium leak testing of closure features using methods that can demonstrate the defined leak-tight requirements have been met. Leak testing shall be performed in accordance with ANSI N14.5-97.
- (2) Helium shall be the only gas used for final backfill operations.
- (3) Closure welds shall be used for TAD canister containment in accordance with standard nuclear industry practice. ASME Boiler and Pressure Vessel Code shall be used for design, procedure and qualification requirements.
- (4) In accordance with industry standards and regulatory guidance, the TAD canister shall be designed to facilitate the following:
 - a. Draining and vacuum drying to remove water vapor and oxidizing material. The loaded TAD canister shall maintain a 3 torr vacuum for 30 minutes after vacuum pump operation ceases.
 - b. Filling with helium to atmospheric pressure or greater as required to meet leak test procedural requirements.
 - c. Sampling of the gas space to verify helium purity.
 - d. Limiting maximum allowable oxidizing gas concentration within the loaded and sealed TAD canister to 0.20% of the free volume in the TAD canister at atmospheric pressure.
- (5) A loaded TAD canister shall maintain a leakage rate of 1.5×10^{-12} fraction of canister free volume per second (normal) and maintain the cladding temperature below 752° F (normal) following vertical flat-bottom drop of 12 inches onto an unyielding surface.

3.1.7 Operations

- (1) The TAD canister lid shall be designed for handling under water with the TAD in a vertical orientation.
- (2) The TAD canister body and lid shall have features to center and seat the lid during submerged installation. The maximum off-center value is ½ in.
- (3) An integral feature for lifting a vertically oriented, loaded TAD from the top lid, without requiring manual installation and removal of devices and adapters shall be provided. A sketch of the integral lifting feature that shall be used is shown in Attachment C.

⁸ A system performance assessment is a comprehensive analysis estimating dose incurred by reasonably maximally exposed individual, including associated uncertainties, as a result of repository releases caused by all significant features, events, processes, and sequences of events and processes, weighted by their probability of occurrence (YMP 2003, Appendix B).

- (4) An open, empty and vertically oriented TAD canister shall have integral lifting feature(s) provided to allow lifting by an overhead handling system.

3.1.8 Materials

- (1) Required Materials- Except for thermal shunts and criticality control materials, the TAD canister and structural internals (i.e., basket) shall be constructed of a Type 300-series stainless steel (UNS S3XXXX, such as UNS S31603, which may also be designated as type 316L) as listed in ASTM A-276-06, *Standard Specification for Stainless Steel Bars and Shapes*.
- (2) The TAD and its basket materials shall be designed to be compatible with the repository pool water in Table 3.1-4.

Table 3.1-4. Repository Pool Water Specifications	
Average annual pool water temperature	<90° F (Pool water temperature may exceed 110° F for no more than 5% of the time during June, July, August, and September.)
Average annual pool water conductivity	< 3 micro mho per cm
Pool water chloride concentration	< 0.5 ppm
Pool water pH	5.3 to 7.5 (unborated water)

- (3) Prohibited or Restricted Materials
 - a. The TAD canister shall not have organic, hydrocarbon-based materials of construction.
 - b. The TAD canister shall have organic, hydrocarbon-based residue removed to the standard defined in 3.1.8 (3) c. prior to delivery.
 - c. All metal surfaces shall meet surface cleanliness classification C requirement defined in ASME NQA-1-2000 Edition, Subpart 2.1 *Quality Assurance Requirements for Cleaning of Fluid Systems and Associated Components for Nuclear Power Plants*.
 - d. The TAD canister shall not be constructed of pyrophoric materials.
 - e. The TAD canister, including the steel matrix, gaskets, seals, adhesives and solder, shall not be constructed with materials that would be regulated as hazardous wastes under the Resource Conservation and Recovery Act (RCRA) and prohibited from land disposal under RCRA if declared to be waste.
- (4) Markings
 - a. The TAD canister shall be capable of being marked on the lid and body with an identical unique identifier prior to delivery for loading.

- b. The unique identifier space shall be of suitable length and height to contain nine (9) alphanumeric and two (2) special characters (e.g., -, /, “space”, etc.) to be specified by the DOE.
- c. Alphanumeric characters shall have a minimum height of 6 in.
- d. The markings shall remain legible without intervention or maintenance during/after any of the following events:
 - The entire 100 year service life.
 - Normal operations to include loading, closure, storage, transportation, aging and disposal.
 - Dose, heat and irradiation associated with the vendor defined design basis PWR or BWR, as applicable.

3.2 Transportation Overpack

3.2.1 General

- (1) The transportation overpack shall accommodate a TAD canister formed as a right-circular cylinder with a length of 212.0” and diameter of 66.5”; as shown in Attachment C sketch.
- (2) The transportation overpack shall function with a TAD canister that has a maximum loaded weight 54.25 tons.
- (3) The loaded transportation overpack (without impact limiters) shall be designed to be lifted in a vertical orientation by an overhead crane.
- (4) The loaded transportation overpack (without impact limiters) shall be able to stand upright when set down upon a flat horizontal surface without requiring the use of auxiliary supports.
- (5) The size and weight of the loaded transportation overpack shall be limited to the characteristics provided in Table 3.2-1, below.

Table 3.2-1 Transportation Overpack Characteristics

Characteristic	Value
Maximum cask length without impact limiters (in.)	230
Maximum cask length with impact limiters (in.)	333
Maximum cask diameter without impact limiters (in.)	98
Maximum cask lid diameter (in.)	84
Maximum distance across upper trunnions (in.)	108
Maximum diameter of impact limiters (in.)	126
Maximum cask weight when fully loaded (lb.)	250,000

- (6) Lifting attachments and appurtenances on transportation overpacks, overpack lids and impact limiters shall be designed, documented and fabricated in accordance with NUREG-0612 *Control of Heavy Loads at Nuclear Power Plants*.

3.2.2 Structural

A loaded TAD canister contained within a transportation overpack assembled with any other components included in the packaging, as defined in 10 CFR part 71, shall meet the requirements for a Type B cask as specified in 10 CFR part 71, as evidenced by a valid Certificate of Compliance.

3.2.3 Thermal

- (1) During normal operations, the CSNF cladding temperature in the TAD canister shall not exceed 752° F. Normal operations include transportation from purchaser sites to the GROA.
- (2) Transportation overpacks cooling features and mechanisms shall be passive.

3.2.4 Dose and Shielding

- (1) The transportation overpack impact limiters shall include design and handling features that use standardized tools and features that simplify removal operations.
- (2) Transportation overpack shall be designed such that contamination on accessible external surfaces shall be removable to:
 - a. 1,000 dpm/100 cm² - beta-gamma with a wipe efficiency of 0.1.
 - b. 20 dpm/100 cm² - alpha with a wipe efficiency of 0.1.

3.2.5 Criticality

No specific requirements beyond those of 10 CFR part 71.

3.2.6 Containment

The loaded transportation overpack shall have a tamper indicating device (TID) that meets requirements of 10 CFR part 73 *Physical Protection of Plants and Materials*.

3.2.7 Operations

- (1) Normal operational procedures shall **not** require submergence of the transportation overpack into CSNF handling pool water at repository or loading site.
- (2) Transportation overpack shall have closures that can be bolted and unbolted using standard tools. Standard tools are those that can be found in industrial tool catalogs.

- (3) The transportation overpack shall have two (2) upper and two (2) lower trunnions located between 44 in. and 51 in. from each end.
- (4) The transportation overpack shall be designed to permit the transportation overpack, without impact limiters, to be upended by rotation about its lower trunnions and removed in a vertical orientation via overhead crane.
- (5) The transportation overpack shall have upper lifting trunnions with dual seats and lower turning trunnions.
- (6) Trunnions shall remain attached to the transportation overpack body during transport.
- (7) The transportation overpack lid shall have lift(ing) feature(s) (either fixed or removable) such that it can be lifted via the same grapple used to lift a vertically oriented, loaded TAD canister. A sketch of the TAD canister integral lifting feature is shown in Attachment C.

3.2.8 Materials

Materials selections shall be as necessary to meet requirements of 10 CFR part 71 and other requirements of this specification.

3.3 **Aging Overpack**

3.3.1 General

- (1) The aging overpack shall accommodate a TAD canister that is based on a right-circular cylinder with a length of 212.0” and diameter of 66.5” as shown in Attachment C sketch.
- (2) The aging overpack shall function with a loaded TAD canister having a maximum gross weight of 54.25 tons.
- (3) The combined size and weight of the loaded TAD aging overpack shall be limited to ensure handling at the GROA. The limits are provided in Table 3.3-1.

Maximum overpack diameter	139 in.
Maximum overpack lid diameter	84 in.
Maximum overpack length	264 in.
Maximum overpack weight	200 tons

- (4) The aging overpack shall meet the operational requirements detailed in sketch presented in Attachment D.
- (5) The aging overpack shall be designed to be moved in a vertical orientation.

- (6) The aging overpack lid shall have a lifting ring compatible with the TAD canister grapple.
- (7) The designed maintainable service lifetime of the aging overpack shall be a minimum of 100 years.

3.3.2 Structural

- (1) The TAD canister in an aging overpack shall be required to meet temperature and leak tightness standards for 2,000-year and 10,000-year design basis seismic events. The seismic return vertical and horizontal accelerations are defined in Attachment A of this performance specification.
 - a. Following a 2,000-year seismic return period event, a TAD canister in an aging overpack, shall maintain a maximum leakage rate of 1.5×10^{-12} fraction of canister free volume per second (normal) and maximum cladding temperature of 752° F (normal).
 - b. Following a 10,000-year seismic return period event, a TAD canister in an aging overpack shall maintain a maximum leakage rate of 1.5×10^{-12} fraction of canister free volume per second (normal) and cladding temperature limit of 1,058° F (off-normal) following a seismic event defined by the 10,000-year seismic return period.
- (2) During GROA operations, an aging overpack shall be designed to maintain a maximum TAD canister leakage rate of 1.5×10^{-12} fraction of free volume per second (normal) and cladding temperature limits (see inset) during and following exposure to the environmental conditions listed below.

For 2a - 2e below, the cladding temperature limits are 752° F and 1,058° F for “normal” and “off-normal” limits, respectively.
--

- a. These environmental conditions are not cumulative but occur independently:
 - Outdoor average daily temperature range of 2° F to 116° F with insolation as specified in 10 CFR part 71 (normal)
 - An extreme wind gust of 90 mph for 3-sec (normal)
 - Maximum tornado wind speed of 189 mph with a corresponding pressure drop of 0.81 lb/in² and a rate of pressure drop of 0.30 lb/in²/sec (off-normal). The spectrum of missiles from the maximum tornado is provided in Table 3.3-2 (off-normal).

Table 3.3-2 Spectrum of Missiles

Missile	Mass (lb)	Dimensions (ft)	Hor. Vel. (ft/s)
Wood Plank	114.6	0.301 × 0.948 × 12	190.2
6" Schedule 40 pipe	286.6	0.551D × 15.02	32.8
1 in. steel rod	8.8	0.0833D × 3	26.3
Utility Pole	1,124	1.125D × 35.04	85.3
12" Schedule 40 pipe	749.6	1.05D × 15.02	23.0
Automobile	3,990	16.4 × 6.6 × 4.27	134.5

- b. Annual precipitation of 20 inches/year (normal). The spectrum of rainfall is provided in Table 3.3-3 (normal):

Table 3.3-3 Spectrum of Rainfall

Parameter and Frequency	Nominal Estimate	Upper Bound 90% Confidence Interval*
Maximum 24-hr precipitation (50-year return period)	2.79 in./day	3.30 in./day
Maximum 24-hr precipitation (100-year return period)	3.23 in./day	3.84 in./day
Maximum 24-hr precipitation (500-year return period)	4.37 in./day	5.25 in./day
Precipitation 1-hr intensity (50-year return period)	1.35 in./hr	1.72 in./hr
Precipitation 1-hr intensity (100-year return period)	1.68 in./hr	2.15 in./hr

*Use the values for upper bound 90% confidence interval.

- c. Maximum daily snowfall of 6.0 in. (normal)
- d. Maximum monthly snowfall of 6.6 in. (normal)
- e. A lightning strike with a peak current of 250 kiloamps over a period of 260 microseconds and a continuing current of 2 kiloamps for 2 seconds (off-normal).
- (3) Following an impact (with resultant fire) from an F-15 military aircraft into an aging overpack, the TAD canister shall maintain a maximum leak rate of 9.3×10^{-10} fraction of canister free volume per second (off-normal) and maximum cladding temperature 1,058° F (off-normal). The analysis shall assume the following:
- The crash speed is 500 ft/sec.
 - Impact orientation analyzed shall be that which results in maximum damage.
 - 12,000 lbs of JP-8 fuel.
 - F-15 airframe.

- e. Two engine components of 3,740 lbs. and dimensions of 46.5 inches D × 191 inches each spaced 96 inches apart.
 - f. One (1) M61A1 20-mm cannon mounted internally just off center of axis.
 - g. 1,000 lbs of inert armaments (i.e., dummy bombs) located between the engines.
- (4) The TAD canister in an aging overpack shall be designed to a maximum leakage rate of 1.5×10^{-12} fraction of canister free volume per second (normal) and maximum cladding temperature of 1,058° F (off-normal) following 4 in. of volcanic ash accumulation. The aging overpack may be on a site transporter. The ash fall loads are estimated at 21 lb/ft² with a thermal conductivity of 0.11 BTU/hr-ft-° F.

3.3.3 Thermal

- (1) Aging overpack cooling features and mechanisms shall be passive.
- (2) A loaded aging overpack shall be capable of withstanding a fully engulfing fire without the TAD canister exceeding a leakage rate of 9.3×10^{-10} fraction of canister free volume per second (off-normal) and maximum fuel cladding temperature of 1,058° F (off-normal) under the conditions below.
 - a. The resulting fire described in section 3.3.2 (3) (aircraft impact) of this performance specification.
 - b. The fire described in 10 CFR 71.73.c (4) *Hypothetical Accident Condition* requirements as modified below.
 - 1. The 30-minute period shall be replaced by a period to be determined by calculation of a pool spill fire formed by 100 gallons of diesel fuel.
 - 2. Additionally, a surrogate fully engulfing fire of duration twice the duration of the pool fire which starts simultaneously with the pool fire and with a steady-state heat release rate of 10 MW shall be used to model the burning rate of all other solid and liquid combustible materials. For this purpose, assume the heat transfer conditions specified in 10 CFR 71.73.c (4). Temperature conditions from this fire shall be consistent with a totally engulfing black body emitting from the 10 MW requirement.
 - c. A loaded aging overpack shall withstand a deflagration blast wave, fuel tank projectiles and incident thermal radiation resulting from the worst case engulfing fire⁹ determined in the previous fire protection requirement without the TAD canister exceeding a leakage rate of 9.3×10^{-10} fraction of

⁹ For this analysis, assume the total quantity of fuel shall vaporize into an efficient fuel-air mixture producing an explosive event. Effects of heat generation, fuel tank projectiles and blast wave propagation shall be considered.

canister free volume per second (off-normal) and maximum fuel cladding temperature of 1,058° F (off-normal).

3.3.4 Dose and Shielding

The loaded aging overpack combined neutron and gamma dose rate shall not exceed 40 mrem/hr on contact at any location on the exterior surface.

3.3.5 Criticality

The aging overpack must be designed, fabricated and operated to support the design basis for the TAD for nuclear criticality mitigation.

3.3.6 Containment

The aging overpack shall be designed such that following a 3-ft vertical drop or tip over from a 3-ft high site transporter, the TAD canister maximum leak rate is 9.3×10^{-10} fraction of canister free volume per second (off-normal) under applicable repository environmental conditions.

3.3.7 Operations

- (1) The aging overpack shall be designed to receive, age, and discharge a loaded TAD canister in a vertical orientation.
- (2) The loaded aging overpack shall be transportable on site in a vertical orientation.
- (3) The loaded aging overpack shall be designed to remain in its transport orientation when set down on a flat horizontal surface without use of auxiliary supports.
- (4) The aging overpack shall have a vendor designed fixture(s) such that the loaded aging overpack can be handled via an overhead crane.
- (5) The loaded aging overpack shall be designed to be moved to the aging pad via site transporter using a pair of lift beams (e.g., forklift). A sketch showing the interface is shown in Attachment D.
- (6) The aging overpack shall be capable of being transported by air pallet.

3.3.8 Materials

No material requirements, prohibitions, or restrictions have been identified for the aging overpack.

4.0 GLOSSARY

The following section incorporates the definitions and descriptions of major “terms of art” used throughout this document.

Aging- Safely placing commercial CSNF in a site-specific overpack on an aging pad for a long period of time (years) for radioactive decay. Radioactive decay results in a cooler waste form to ensure thermal limits can be met. Safely aging CSNF is an integral part of GROA operations to ensure material has significantly decayed to meet licensed thermal limitations.

Burnup- A measure of nuclear reactor fuel consumption expressed either as the percentage of fuel atoms that have undergone fission or as the amount of energy produced per initial unit weight of fuel.

Canister- The structure surrounding the waste form that facilitates handling, storage, aging and/or transportation.

1. For CSNF, the canister may provide structural support for intact CSNF, loose rods, non-fuel components and confinement of radionuclides.
2. Canistered waste shall be placed in waste packages prior to emplacement.

Cladding- The metallic outer sheath of a fuel rod generally made of a zirconium alloy. It is intended to isolate the fuel from the external environment.

Design Bases- That information that identifies the specific functions to be performed by a structure, system, or component of a facility and the specific values or ranges of values chosen for controlling parameters as reference bounds for design. These values may be constraints derived from generally accepted “state-of-the-art” practices for achieving functional goals or requirements derived from analysis (based on calculation or experiments) of the effects of a postulated event under which a structure, system, or component must meet its functional goals. The values for controlling parameters for external events include:

1. Estimates of severe natural events to be used for deriving design bases that will be based on consideration of historical data on the associated parameters, physical data, or analysis of upper limits of the physical processes involved; and,
2. Estimates of severe external human-induced events to be used for deriving design bases, which will be based on analysis of human activity in the region, taking into account the site characteristics and the risks associated with the event.

Event Sequence- A series of actions and/or occurrences within the natural and engineered components of a GROA that could potentially lead to exposure of individuals to radiation. An event sequence includes one or more initiating events and associated combinations of repository system component failures, including those produced by the action or inaction of operating personnel. Those event sequences that are expected to occur one or more times before permanent closure of the geologic repository operations area are referred to as Category 1 event sequences. Other event sequences that have at least one chance in 10,000 of occurring before permanent closure are referred to as Category 2 event sequences.

Fuel assembly- A number of fuel rods held together by plates and separated by spacers used in a reactor. This assembly is sometimes called a fuel bundle or fuel element.

Geologic Repository Operations Area (GROA)- A high-level radioactive waste facility that is part of a geologic repository, including both surface and subsurface areas, where wet handling activities are conducted.

Hypothetical Accident Conditions- The sequential conditions and tests defined in 10 CFR part 71 subpart E (Package Approval Standards) and subpart F (Package, Special Form and LSA-III Tests) that a package (or array of packages) must be evaluated against.

High-Level Radioactive Waste (HLW)- (1) The highly radioactive material resulting from the reprocessing of spent nuclear fuel, including liquid waste produced directly in reprocessing and any solid material derived from such liquid waste that contains fission products in sufficient concentrations; (2) Irradiated reactor fuel; and (3) Other highly radioactive material that the Commission, consistent with existing law, determines by rule requires permanent isolation.

Important to Safety- In reference to structures, systems and components, means those engineered features of the GROA whose function is:

- (1) To provide reasonable assurance that high-level waste can be received, handled, packaged, stored, emplaced, and retrieved without exceeding the requirements of §63.111(b)(1) for Category 1 event sequences; or
- (2) To prevent or mitigate Category 2 event sequences that could result in radiological exposures exceeding the values specified at §63.111(b)(2) to any individual located on or beyond any point on the boundary of the site.

Important to Waste Isolation- With reference to design of the engineered barrier system and characterization of natural barriers, means those engineered and natural barriers whose function is to provide a reasonable expectation that high-level waste can be disposed of without exceeding the requirements of 10 CFR 63.113(b) and (c).

Neutron Absorber- A material (e.g., boron) that absorbs neutrons used in nuclear reactors, transportation overpacks and waste packages to control neutron multiplication.

Normal Conditions of Transport- The conditions and tests defined in 10 CFR part 71 subpart E (Package Approval Standards) and subpart F (Package, Special Form and LSA-III Tests) that all packages must be evaluated against.

Postclosure- The period of time after closure of the geologic repository.

Preclosure- The period of time before and during closure of the GROA disposal system.

Site- An area surrounding the GROA for which the DOE exercises authority over its use in accordance with the provisions of 10 CFR part 63.

Site Transporter- A self-powered vehicle designed to haul the TAD canister and contents while within either a shielded transfer cask or aging overpack between GROA surface facilities.

Shielded Transfer Cask (STC)- A cask that meets applicable requirements for safe transfer of a TAD canister and its contents between various surface facilities.

Spent Nuclear Fuel (SNF)- Fuel withdrawn from a nuclear reactor following irradiation, the constituent elements of which have not been separated by reprocessing.

Storage- For the purposes of this specification, the placement, by a licensee and/or purchasers, of spent nuclear fuel in independent spent fuel storage installations (ISFSI) certified under title 10 CFR part 72.

TAD System- The set of components consisting of one or more TAD canisters, transportation overpacks, transportation skids, ancillary equipments, shielded transfer casks, aging overpacks and site transporters used to facilitate handling of CSNF.

Total Effective Dose Equivalent- For purposes of assessing doses to workers, the sum of the deep-dose equivalent (for external exposures) and committed effective dose equivalent (for internal exposures).

Transportation Overpack- The assembly of components of the packaging intended to retain the radioactive material during transport.

Trunnion- Cylindrical protuberance for supporting and/or lifting located on the outside of a container or cask (e.g., waste package, aging overpack, etc.)

Waste package- The waste form and any containers, shielding, packing and other absorbent materials immediately surrounding an individual waste container.

Attachment A

Seismic Data for Yucca Mountain Geologic Repository Operations Area

**PAGE INTENTIONALLY
LEFT BLANK**

Summary of Seismic Data for Yucca Mountain Surface Facilities

Table 1. Peak Ground Motions Associated with Ground Motion Categories

Part A: Horizontal Ground Accelerations

Ground Motion Category	Return Period ^b (years)	Horizontal Peak Ground Acceleration ^a (PGA) (g)		DTN
		Surface ^{c,d}	Subsurface	
DBGM-1	1,000	0.37	0.13	MO0411SDSDE103.003 MO0405SDSTPNTB.001
DBGM-2	2,000	0.58	0.19	MO0411SDSTMHIS.006 MO0407SDARS104.001
BDBGM	10,000	1.19	0.43	MO0411WHBDE104.003 MO0306SDSAVDTH.000

Part B: Vertical Ground Accelerations

Ground Motion Category	Return Period ^b (years)	Vertical Peak Ground Acceleration ^a (PGA) (g)		DTN
		Surface ^{c,d}	Subsurface	
DBGM-1	1,000	0.28	0.12	MO0411SDSDE103.003, MO0405SDSTPNTB.001
DBGM-2	2,000	0.52	0.23	MO0411SDSTMHIS.006, MO0407SDARS104.001
BDBGM	10,000	1.49	0.62	MO0411WHBDE104.003, MO0306SDSAVDTH.000

NOTES:

- a) The PGA value is the spectral acceleration at a frequency of 100 Hz (period = 0.01 second) at 5% damping.
- b) A return period of 1,000 years equals a mean annual probability of exceedance (MAPE) of 1.0×10^{-3} ; similarly, a return period of 2,000 years equals a MAPE of 5.0×10^{-4} and a return period of 10,000 years equals a MAPE of 1.0×10^{-4} .
- c) Surface values were defined for the Geotechnical Data for a Potential Wet handling Building and for Ground Motion Analyses for the Yucca Mountain Site Characterization Project (BSC 2002, Figure 1) based on profiles for 35 ft (11 m) and 110 ft (34 m) of alluvium (soil).
- d) PGA values for surface facilities are computed at Point D/E. Location of computation points for surface facilities and emplacement level is shown in Development of Earthquake Ground Motion Input for Preclosure Seismic Design and Postclosure Performance Assessment of a Geologic Repository at Yucca Mountain, NV (BSC 2004, Figure 1).

BDBGM = beyond design basis ground motion; DBGM = design basis ground motion; DTN = document tracking number; g = acceleration due to gravity.

Table 2. Spectral Ground Motions Associated with Ground Motion Categories

Part A: Horizontal Spectral Accelerations

Ground Motion Category	Return Period (years)	Average Horizontal Spectral Accelerations ^a (g)			DTN
		Range	Surface ^{b,c}	Subsurface	
DBGM-1	1,000	S _{A(1-2.5)}	0.43	0.17	MO0411SDSDE103.003, MO0405SDSTPNTB.001
		S _{A(5-10)}	0.80	0.25	
DBGM-2	2,000	S _{A(1-2.5)}	0.67	0.24	MO0411SDSTMHIS.006, MO0407SDARS104.001
		S _{A(5-10)}	1.22	0.37	
BDBGM	10,000	S _{A(1-2.5)}	1.58	0.55	MO0411WHBDE104.003, MO0306SDSAVDTH.000
		S _{A(5-10)}	2.52	0.83	

Part B: Vertical Accelerations

Ground Motion Category	Return Period (years)	Average Vertical Spectral Accelerations ^a (g)			DTN
		Range	Surface ^{b,c}	Subsurface	
DBGM-1	1,000	S _{A(1-2.5)}	0.20	0.13	MO0411SDSDE103.003, MO0405SDSTPNTB.001
		S _{A(5-10)}	0.53	0.23	
DBGM-2	2,000	S _{A(1-2.5)}	0.34	0.22	MO0411SDSTMHIS.006, MO0407SDARS104.001
		S _{A(5-10)}	0.90	0.41	
BDBGM	10,000	S _{A(1-2.5)}	0.86	0.58	MO0411WHBDE104.003, MO0306SDSAVDTH.000
		S _{A(5-10)}	2.47	1.03	

NOTES:

^a Spectral accelerations are defined as: $S_{A(1-2.5)} = [(SA_1 + SA_{2.5}) / 2]$ and $S_{A(5-10)} = [(SA_5 + SA_{10}) / 2]$, where SA₁, SA_{2.5}, SA₅, and SA₁₀ are the maximum horizontal spectral accelerations at 1 Hz, 2.5 Hz, 5 Hz, and 10 Hz, respectively, for 5% damping.

^b Surface values are defined for the *Geotechnical Data for a Potential Wet handling Building and for Ground Motion Analyses for the Yucca Mountain Site Characterization Project* (BSC 2002, Figure 1) based on profiles for 35 ft (11 m) and 110 ft (34 m) of alluvium (soil).

^c Acceleration values for surface facilities are computed at Point D/E. Location of computation points for surface facilities and emplacement level is shown in *Development of Earthquake Ground Motion Input for Preclosure Seismic Design and Postclosure Performance Assessment of a Geologic Repository at Yucca Mountain, NV* (BSC 2004, Figure 1).

BDBGM = beyond design basis ground motion; DBGM = design basis ground motion; DTN = document tracking number; g = acceleration due to gravity; SA = spectral acceleration; S_{A(X-Y)} = average spectral acceleration for a range, computed as the average of spectral accelerations at frequencies of X and Y.

Table 3. Maximum Horizontal Spectral Accelerations at Surface for 2,000-Year Return Period Seismic Event

Period (sec)	Spectral Acceleration At Different Damping Levels (g)								
	0.5%	1.0%	2.0%	3.0%	5.0%	7.0%	10%	15%	20%
0.010	0.5802	0.5802	0.5802	0.5802	0.5802	0.5802	0.5802	0.5802	0.5802
0.011	0.5973	0.5973	0.5973	0.5973	0.5973	0.5973	0.5973	0.5973	0.5973
0.012	0.6194	0.6194	0.6194	0.6194	0.6194	0.6194	0.6194	0.6194	0.6194
0.014	0.8274	0.7628	0.6982	0.6604	0.6470	0.6426	0.6343	0.6249	0.6182
0.017	1.0026	0.8910	0.7795	0.7142	0.6808	0.6685	0.6522	0.6337	0.6205
0.020	1.2153	1.0497	0.8842	0.7873	0.7302	0.7083	0.6826	0.6533	0.6325
0.025	1.4818	1.2525	1.0233	0.8892	0.8031	0.7545	0.7145	0.6689	0.6365
0.034	1.8822	1.5604	1.2386	1.0504	0.9194	0.8239	0.7606	0.6886	0.6375
0.050	2.4206	1.9810	1.5414	1.2842	1.0897	0.9551	0.8638	0.7600	0.6864
0.100	2.9209	2.3812	1.8414	1.5256	1.2512	1.0728	0.9464	0.8027	0.7007
0.110	2.9076	2.3719	1.8362	1.5229	1.2453	1.0662	0.9383	0.7929	0.6898
0.123	2.8864	2.3574	1.8284	1.5189	1.2380	1.0582	0.9287	0.7815	0.6771
0.142	2.8545	2.3356	1.8167	1.5132	1.2292	1.0491	0.9180	0.7690	0.6632
0.167	2.7904	2.2892	1.7881	1.4950	1.2106	1.0318	0.9001	0.7504	0.6442
0.201	2.6829	2.2092	1.7354	1.4583	1.1779	1.0031	0.8725	0.7239	0.6185
0.248	2.5572	2.1160	1.6749	1.4168	1.1422	0.9726	0.8436	0.6969	0.5929
0.335	2.2450	1.8732	1.5014	1.2839	1.0341	0.8816	0.7623	0.6268	0.5306
0.498	1.7176	1.4514	1.1852	1.0295	0.8309	0.7107	0.6131	0.5021	0.4233
1.000	0.7299	0.6332	0.5365	0.4799	0.3918	0.3384	0.2918	0.2389	0.2014
1.123	0.6204	0.5407	0.4611	0.4144	0.3394	0.2937	0.2535	0.2077	0.1753
1.262	0.5282	0.4626	0.3970	0.3586	0.2946	0.2556	0.2208	0.1812	0.1530
1.417	0.4495	0.3956	0.3416	0.3101	0.2557	0.2224	0.1923	0.1580	0.1337
1.668	0.3575	0.3168	0.2761	0.2523	0.2092	0.1827	0.1583	0.1305	0.1108
2.009	0.2734	0.2442	0.2151	0.1980	0.1654	0.1452	0.1261	0.1044	0.0890
2.477	0.2012	0.1814	0.1616	0.1500	0.1265	0.1118	0.0975	0.0813	0.0697
3.351	0.1215	0.1110	0.1006	0.0945	0.0810	0.0724	0.0636	0.0537	0.0467
4.978	0.0614	0.0572	0.0530	0.0505	0.0445	0.0405	0.0362	0.0312	0.0277
10.000	0.0126	0.0122	0.0119	0.0116	0.0110	0.0105	0.0098	0.0089	0.0083

Source: MO0411SDSTMHIS.006. Seismic Design Spectra and Time Histories for the Surface Facilities Area (Point D/E) at 5E-4 Annual Exceedance Frequency.

NOTES: g = acceleration due to gravity; sec = second.

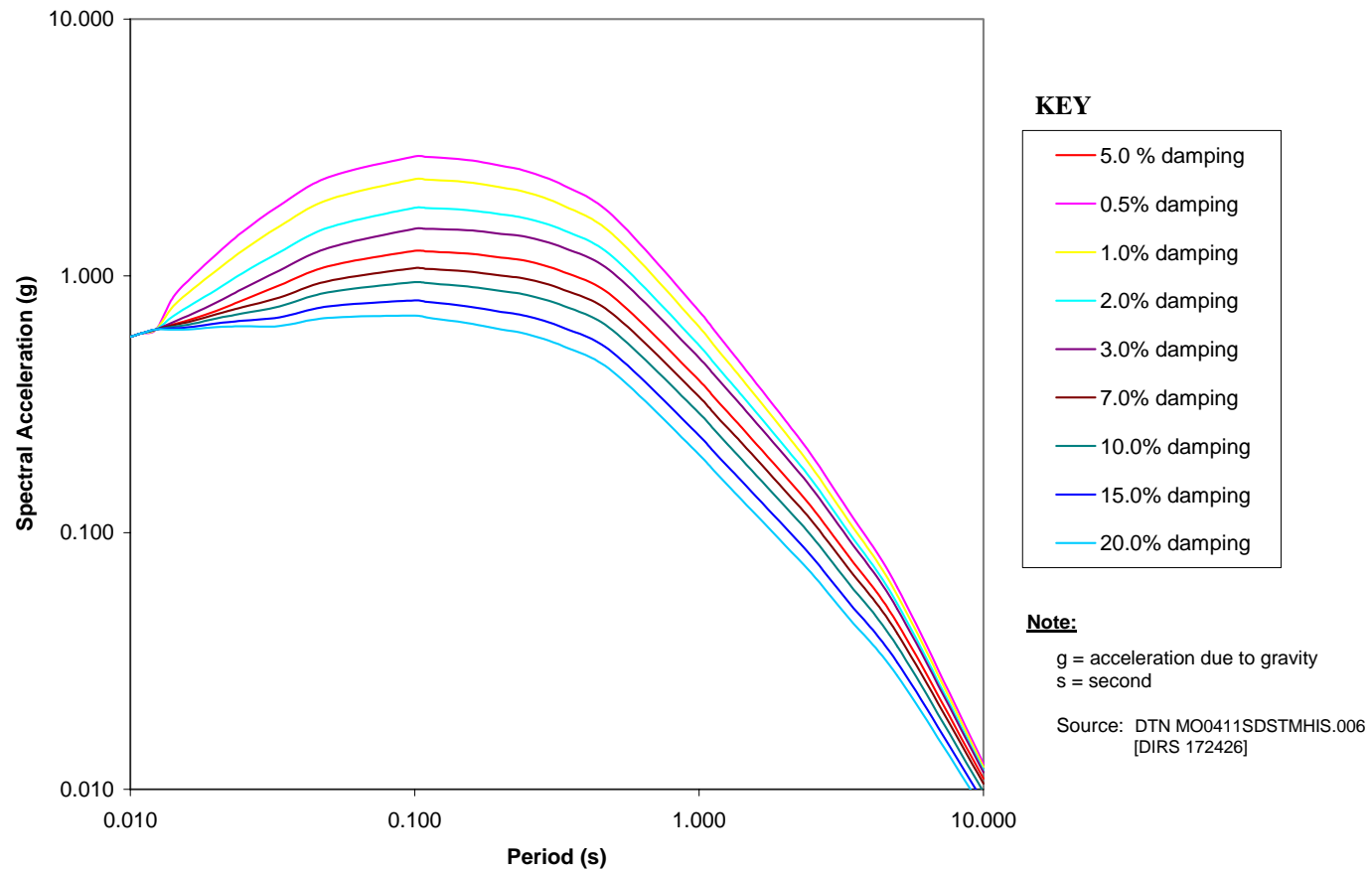

Figure 1 Maximum Horizontal Spectra at Surface for Multiple Damping Levels for 2,000-Year Return Period Seismic Event

Table 4. Vertical Spectral Accelerations at Surface for 2,000-Year Return Period Seismic Event

Period (sec)	Spectral Acceleration At Different Damping Levels (g)								
	0.5%	1.0%	2.0%	3.0%	5.0%	7.0%	10%	15%	20%
0.010	0.5188	0.5188	0.5188	0.5188	0.5188	0.5188	0.5188	0.5188	0.5188
0.011	0.5413	0.5413	0.5413	0.5413	0.5413	0.5413	0.5413	0.5413	0.5413
0.012	0.5709	0.5709	0.5709	0.5709	0.5709	0.5709	0.5709	0.5709	0.5709
0.014	0.8412	0.7613	0.6814	0.6346	0.6086	0.5902	0.5745	0.5568	0.5442
0.017	1.0315	0.9036	0.7756	0.7008	0.6557	0.6224	0.5971	0.5684	0.5480
0.020	1.2579	1.0739	0.8900	0.7824	0.7141	0.6633	0.6265	0.5846	0.5549
0.025	1.5055	1.2604	1.0152	0.8718	0.7768	0.7065	0.6568	0.6002	0.5600
0.034	1.8666	1.5353	1.2039	1.0101	0.8745	0.7758	0.7069	0.6286	0.5730
0.050	2.2647	1.8411	1.4176	1.1698	0.9842	0.8529	0.7614	0.6573	0.5834
0.100	2.4411	1.9793	1.5176	1.2474	1.0166	0.8619	0.7520	0.6270	0.5384
0.110	2.4119	1.9572	1.5026	1.2366	1.0050	0.8506	0.7407	0.6156	0.5269
0.123	2.3722	1.9276	1.4830	1.2229	0.9907	0.8372	0.7273	0.6024	0.5138
0.142	2.3149	1.8847	1.4545	1.2029	0.9715	0.8199	0.7107	0.5866	0.4985
0.167	2.0742	1.6936	1.3129	1.0903	0.8779	0.7403	0.6404	0.5267	0.4461
0.201	1.8236	1.4948	1.1659	0.9735	0.7819	0.6590	0.5689	0.4664	0.3937
0.248	1.5396	1.2684	0.9972	0.8386	0.6723	0.5667	0.4884	0.3994	0.3363
0.335	1.1633	0.9666	0.7699	0.6549	0.5246	0.4429	0.3811	0.3110	0.2612
0.498	0.7810	0.6574	0.5338	0.4615	0.3705	0.3139	0.2699	0.2200	0.1845
1.000	0.3751	0.3243	0.2736	0.2438	0.1980	0.1694	0.1459	0.1192	0.1003
1.123	0.3315	0.2880	0.2445	0.2191	0.1784	0.1530	0.1319	0.1079	0.0908
1.262	0.2929	0.2557	0.2185	0.1968	0.1608	0.1382	0.1192	0.0977	0.0824
1.417	0.2585	0.2268	0.1951	0.1766	0.1448	0.1248	0.1077	0.0884	0.0747
1.668	0.2166	0.1914	0.1662	0.1515	0.1249	0.1080	0.0935	0.0769	0.0652
2.009	0.1748	0.1558	0.1367	0.1255	0.1043	0.0907	0.0787	0.0650	0.0553
2.477	0.1374	0.1236	0.1098	0.1017	0.0853	0.0747	0.0650	0.0540	0.0462
3.351	0.0904	0.0825	0.0745	0.0699	0.0596	0.0528	0.0463	0.0389	0.0336
4.978	0.0504	0.0469	0.0434	0.0413	0.0362	0.0327	0.0291	0.0249	0.0219
10.000	0.0126	0.0123	0.0119	0.0117	0.0110	0.0105	0.0097	0.0087	0.0080

Source: MO0411SDSTMHIS.006. Seismic Design Spectra and Time Histories for the Surface Facilities Area (Point D/E) at 5E-4 Annual Exceedance Frequency.

NOTES: g = acceleration due to gravity; sec = second.

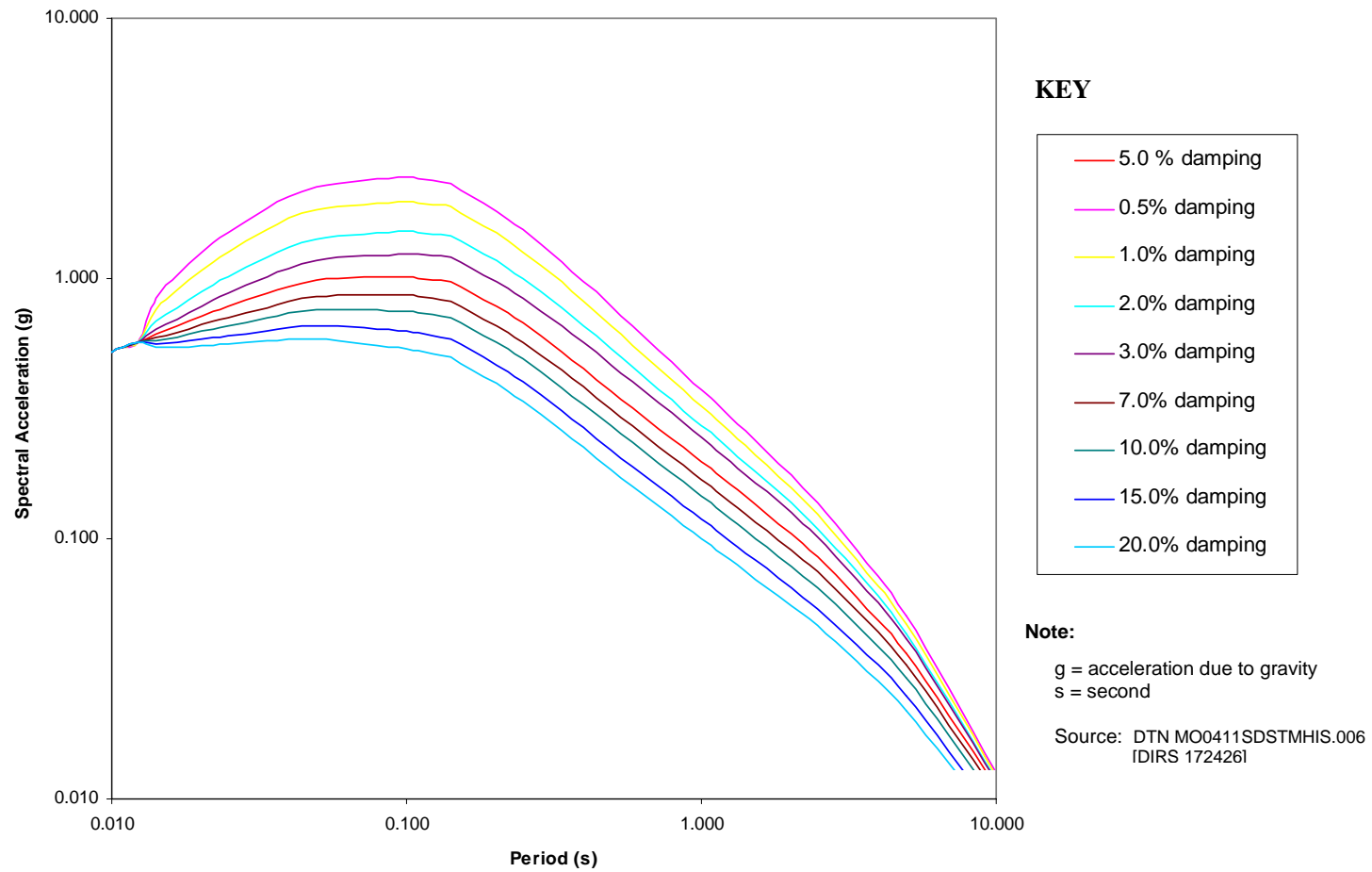

Figure 2. Vertical Spectra at Surface for Multiple Damping Levels for 2,000-Year Return Period Seismic Event

Table 5. Maximum Horizontal Spectral Accelerations at Surface for 10,000-Year Return Period Seismic Event

Period (sec)	Spectral Acceleration At Different Damping Levels (g)								
	0.5%	1.0%	2.0%	3.0%	5.0%	7.0%	10%	15%	20%
0.010	1.1926	1.1926	1.1926	1.1926	1.1926	1.1926	1.1926	1.1926	1.1926
0.011	1.2296	1.2296	1.2296	1.2296	1.2296	1.2296	1.2296	1.2296	1.2296
0.012	1.2775	1.2775	1.2775	1.2775	1.2775	1.2775	1.2775	1.2775	1.2775
0.014	1.7104	1.5768	1.4432	1.3651	1.3374	1.3284	1.3112	1.2917	1.2779
0.017	2.0765	1.8454	1.6144	1.4792	1.4100	1.3845	1.3508	1.3124	1.2852
0.020	2.4923	2.1528	1.8133	1.6147	1.4975	1.4526	1.3998	1.3397	1.2971
0.025	3.0403	2.5699	2.0996	1.8244	1.6478	1.5482	1.4659	1.3724	1.3060
0.034	3.9040	3.2366	2.5692	2.1788	1.9070	1.7089	1.5776	1.4283	1.3224
0.050	5.0495	4.1325	3.2154	2.6790	2.2732	1.9925	1.8020	1.5855	1.4319
0.100	5.9642	4.8620	3.7599	3.1151	2.5548	2.1905	1.9324	1.6389	1.4307
0.110	5.9413	4.8467	3.7521	3.1118	2.5446	2.1786	1.9173	1.6203	1.4095
0.123	5.9030	4.8211	3.7392	3.1063	2.5318	2.1641	1.8993	1.5983	1.3848
0.142	5.8441	4.7818	3.7195	3.0980	2.5166	2.1478	1.8795	1.5744	1.3579
0.167	5.7601	4.7256	3.6912	3.0860	2.4990	2.1299	1.8580	1.5490	1.3297
0.201	5.6363	4.6411	3.6459	3.0638	2.4746	2.1074	1.8329	1.5209	1.2995
0.248	5.2724	4.3629	3.4533	2.9213	2.3550	2.0054	1.7393	1.4369	1.2224
0.335	4.7596	3.9713	3.1831	2.7220	2.1924	1.8690	1.6162	1.3288	1.1249
0.498	4.0273	3.4031	2.7790	2.4139	1.9482	1.6663	1.4374	1.1772	0.9926
1.000	1.9942	1.7299	1.4656	1.3110	1.0704	0.9244	0.7973	0.6528	0.5502
1.123	1.7558	1.5303	1.3048	1.1729	0.9605	0.8313	0.7174	0.5879	0.4960
1.262	1.4946	1.3089	1.1232	1.0146	0.8336	0.7233	0.6247	0.5126	0.4331
1.417	1.2211	1.0745	0.9280	0.8423	0.6946	0.6041	0.5223	0.4293	0.3633
1.668	0.9655	0.8556	0.7456	0.6813	0.5650	0.4934	0.4274	0.3524	0.2991
2.009	0.7473	0.6676	0.5878	0.5412	0.4521	0.3968	0.3447	0.2855	0.2434
2.477	0.5417	0.4884	0.4350	0.4038	0.3406	0.3010	0.2625	0.2188	0.1878
3.351	0.3401	0.3109	0.2816	0.2645	0.2268	0.2027	0.1782	0.1504	0.1307
4.978	0.1813	0.1689	0.1565	0.1492	0.1315	0.1198	0.1069	0.0923	0.0819
10.000	0.0395	0.0384	0.0372	0.0365	0.0345	0.0330	0.0307	0.0280	0.0261

Source: DTN MO0411WHBDE104.003. Seismic Design Spectra and Time Histories for the Surface Facilities Area (Point D/E) at 10-4 Annual Exceedance Frequency.

NOTES: g = acceleration due to gravity; sec = second.

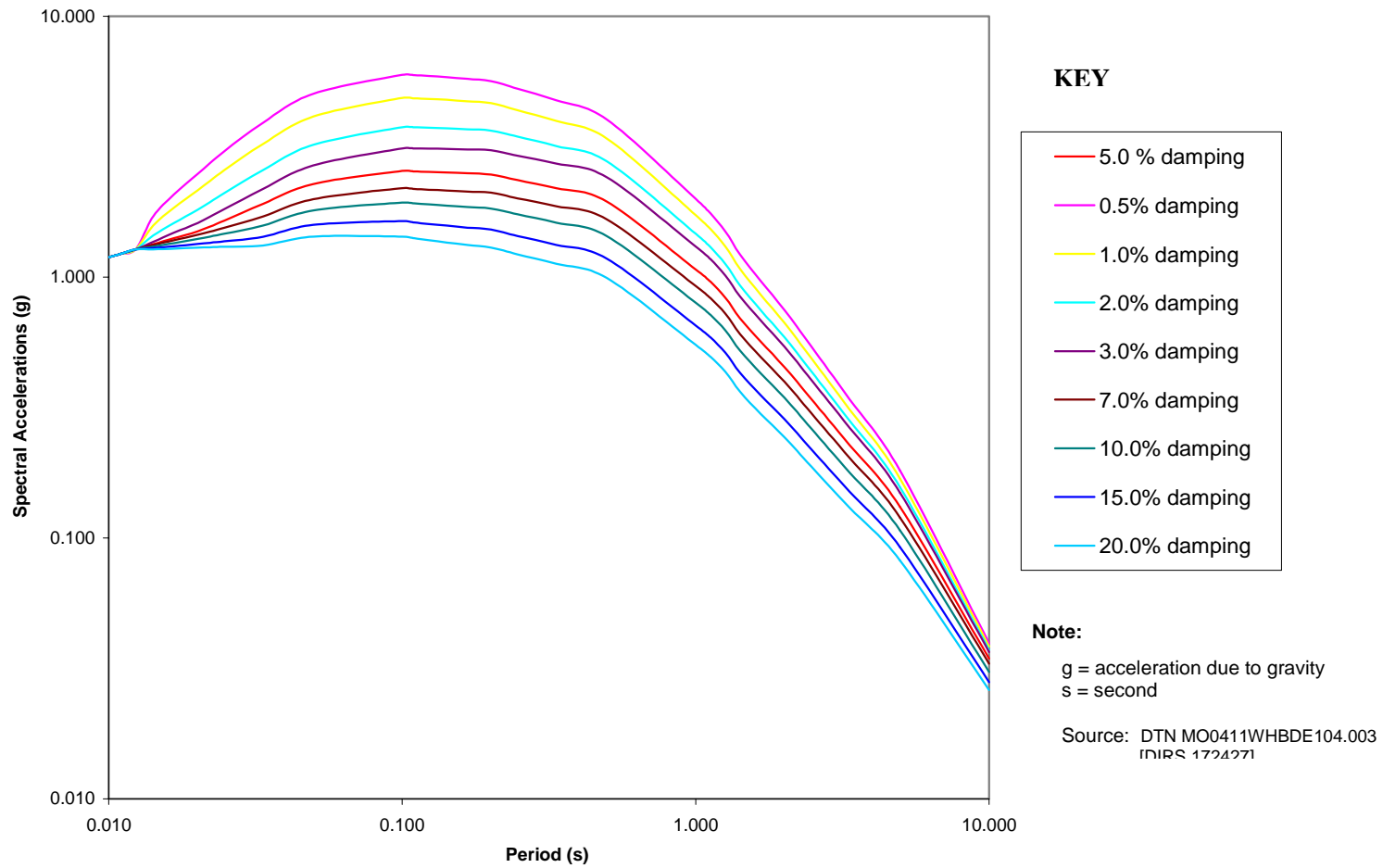

Figure 3. Maximum Horizontal Spectra at Surface for Multiple Damping Levels for 10,000-Year Return Period Seismic Event

Table 6. Vertical Spectral Accelerations at Surface for 10,000-Year Return Period Seismic Event

Period (sec)	Spectral Acceleration At Different Damping Levels (g)								
	0.5%	1.0%	2.0%	3.0%	5.0%	7.0%	10%	15%	20%
0.010	1.4932	1.4932	1.4932	1.4932	1.4932	1.4932	1.4932	1.4932	1.4932
0.011	1.5703	1.5703	1.5703	1.5703	1.5703	1.5703	1.5703	1.5703	1.5703
0.012	1.6723	1.6723	1.6723	1.6723	1.6723	1.6723	1.6723	1.6723	1.6723
0.014	2.4807	2.2450	2.0093	1.8714	1.7947	1.7403	1.6943	1.6420	1.6048
0.017	3.0555	2.6765	2.2975	2.0758	1.9423	1.8437	1.7688	1.6837	1.6233
0.020	3.6683	3.1319	2.5955	2.2817	2.0825	1.9343	1.8269	1.7049	1.6183
0.025	4.3386	3.6321	2.9256	2.5124	2.2386	2.0360	1.8926	1.7296	1.6140
0.034	5.2596	4.3260	3.3924	2.8463	2.4641	2.1860	1.9919	1.7712	1.6146
0.050	6.3125	5.1319	3.9512	3.2606	2.7433	2.3774	2.1222	1.8321	1.6263
0.100	6.9021	5.5965	4.2908	3.5271	2.8744	2.4369	2.1262	1.7729	1.5223
0.110	6.7469	5.4750	4.2031	3.4591	2.8113	2.3795	2.0718	1.7221	1.4740
0.123	6.3388	5.1507	3.9626	3.2676	2.6472	2.2369	1.9434	1.6097	1.3729
0.142	5.8683	4.7778	3.6873	3.0495	2.4628	2.0785	1.8017	1.4870	1.2638
0.167	5.3486	4.3671	3.3856	2.8115	2.2638	1.9090	1.6512	1.3583	1.1504
0.201	4.7952	3.9305	3.0657	2.5598	2.0560	1.7327	1.4958	1.2265	1.0354
0.248	3.9885	3.2859	2.5833	2.1723	1.7416	1.4681	1.2653	1.0347	0.8711
0.335	3.0229	2.5118	2.0007	1.7018	1.3632	1.1509	0.9904	0.8080	0.6786
0.498	1.9764	1.6637	1.3509	1.1680	0.9376	0.7943	0.6831	0.5567	0.4669
1.000	1.0074	0.8710	0.7346	0.6548	0.5317	0.4549	0.3919	0.3202	0.2694
1.123	0.9048	0.7861	0.6673	0.5979	0.4869	0.4175	0.3599	0.2944	0.2479
1.262	0.8123	0.7092	0.6060	0.5457	0.4459	0.3832	0.3306	0.2708	0.2284
1.417	0.7291	0.6397	0.5503	0.4980	0.4084	0.3519	0.3039	0.2494	0.2107
1.668	0.6263	0.5534	0.4805	0.4379	0.3611	0.3124	0.2703	0.2224	0.1884
2.009	0.5213	0.4644	0.4076	0.3743	0.3110	0.2704	0.2345	0.1938	0.1648
2.477	0.4150	0.3733	0.3315	0.3071	0.2576	0.2255	0.1963	0.1631	0.1395
3.351	0.2786	0.2542	0.2297	0.2154	0.1837	0.1627	0.1426	0.1198	0.1036
4.978	0.1454	0.1353	0.1252	0.1192	0.1045	0.0945	0.0839	0.0719	0.0633
10.000	0.0339	0.0329	0.0320	0.0314	0.0295	0.0282	0.0259	0.0234	0.0216

Source: MO0411WHBDE104.003. Seismic Design Spectra and Time Histories for the Surface Facilities Area (Point D/E) at 10-4 Annual Exceedance Frequency.

NOTES: g = acceleration due to gravity; sec = second.

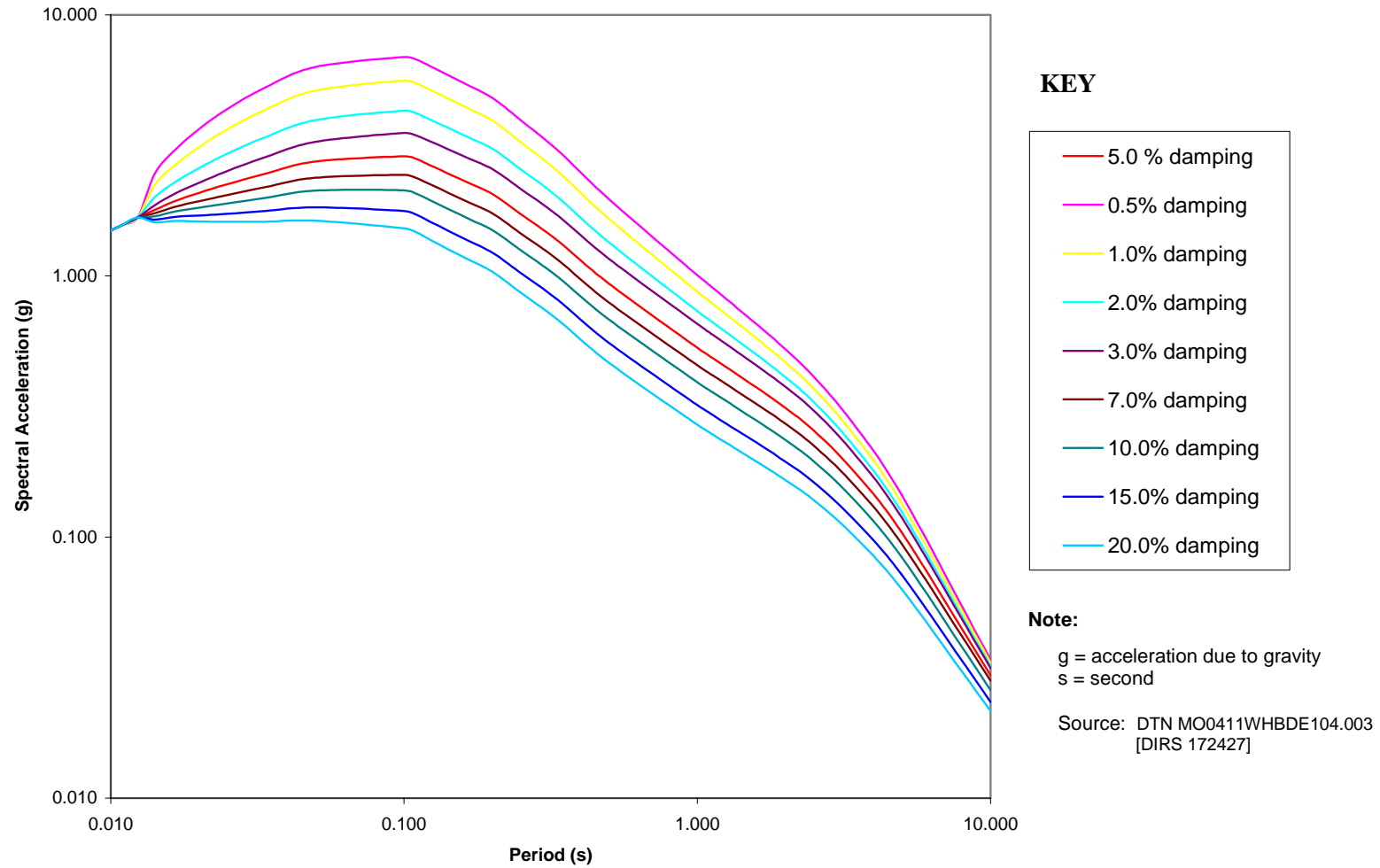

Figure 4. Vertical Spectra at Surface for Multiple Damping Levels for 10,000-Year Return Period Seismic Event

Attachment B

**Example Postclosure Criticality
Loading Curves**

For Illustration Purposes Only

**PAGE INTENTIONALLY
LEFT BLANK**

NOTICE

The Department of Energy is currently developing finalized PWR and BWR postclosure criticality loading curves. The following PWR and BWR loading curves do **NOT** represent the currently defined TAD configuration and materials baseline as detailed in Section 3.1.5 of this Performance Specification. The following loading curves are provided for **Illustrative Purposes Only**. Finalized PWR and BWR postclosure criticality loading curves will be transmitted under separate cover upon completion and approval.

**PAGE INTENTIONALLY
LEFT BLANK**

For Illustration Only

PWR Loading Curve

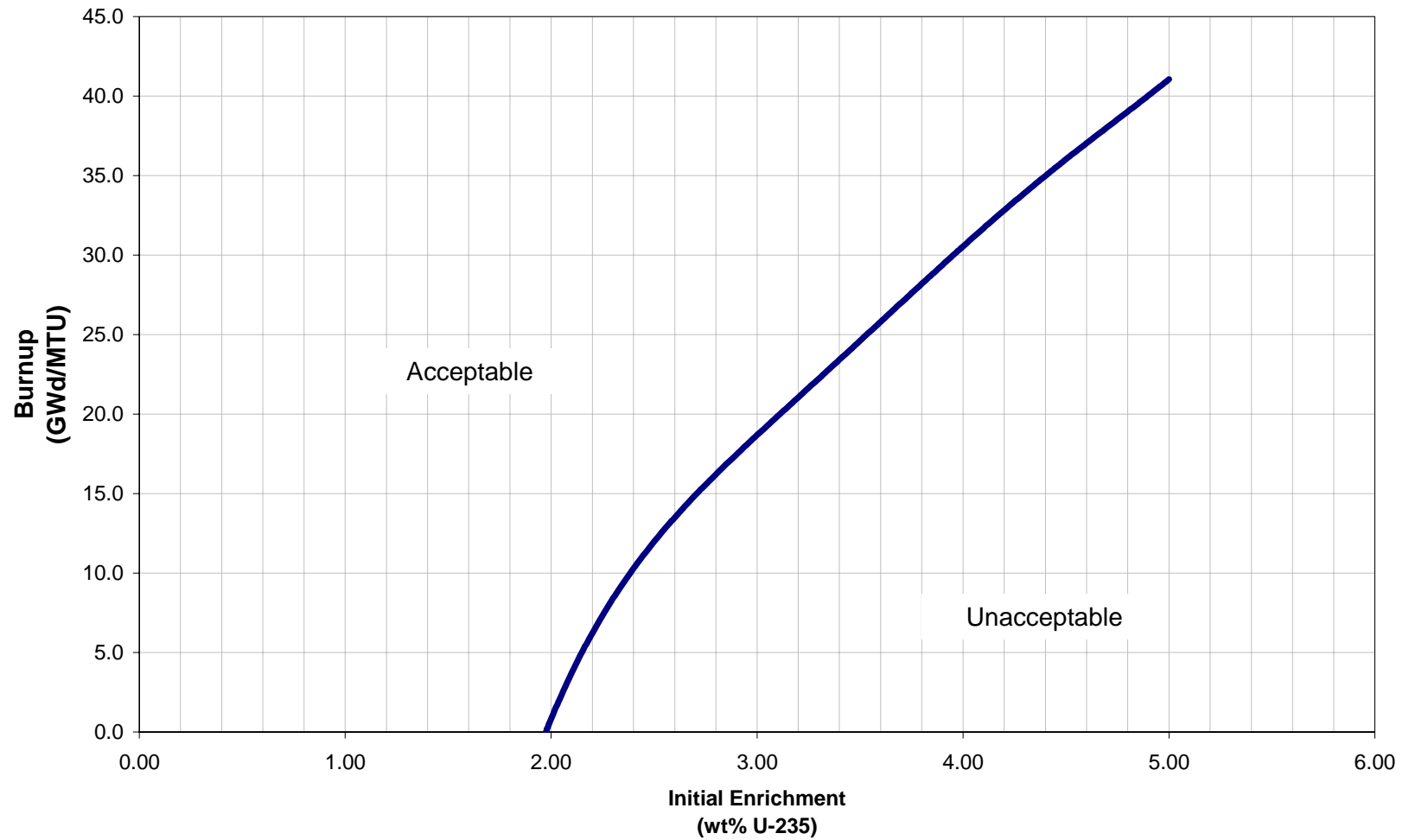

For Illustration Only

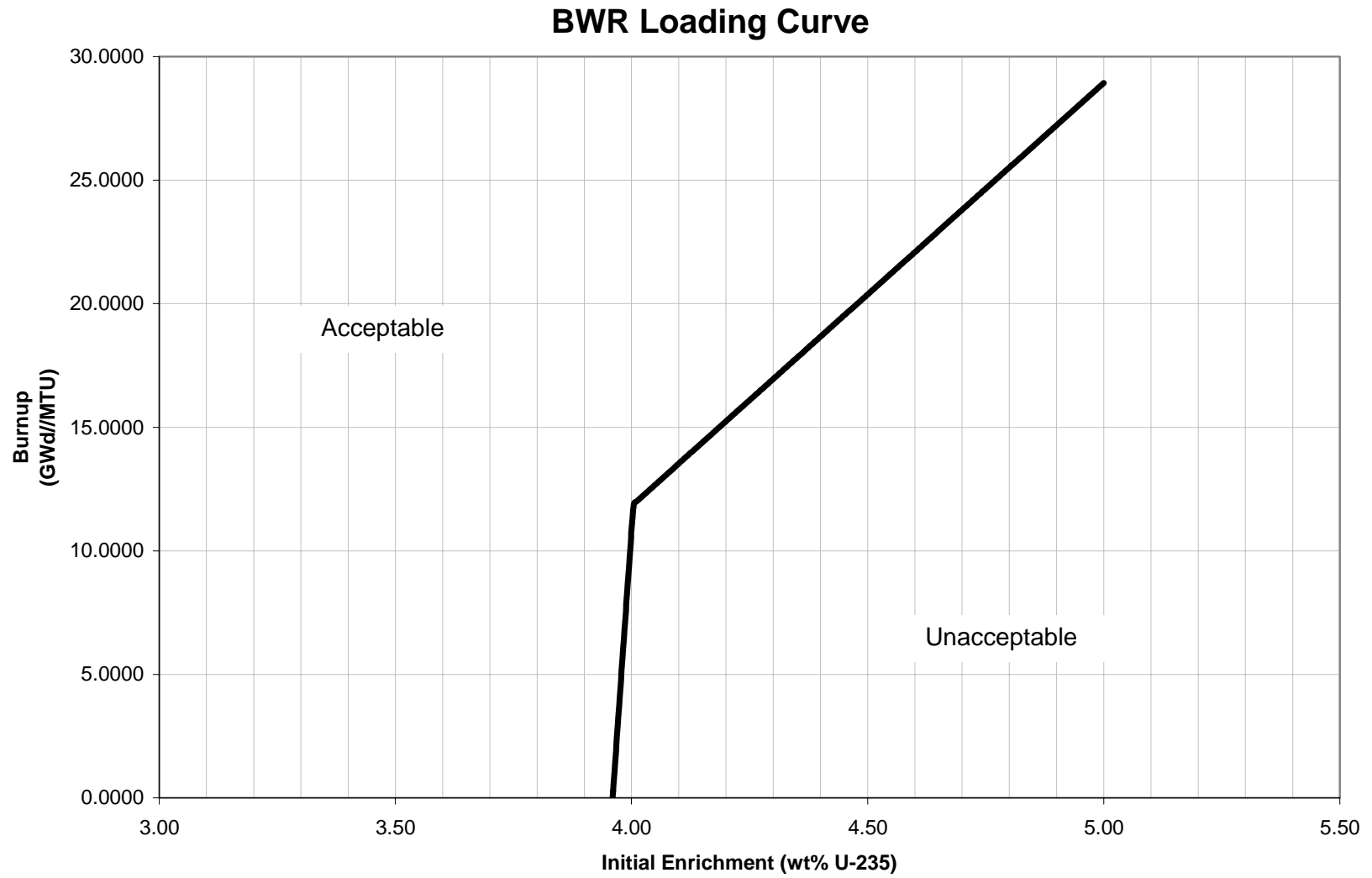

Attachment C

Integral Lifting Ring

**PAGE INTENTIONALLY
LEFT BLANK**

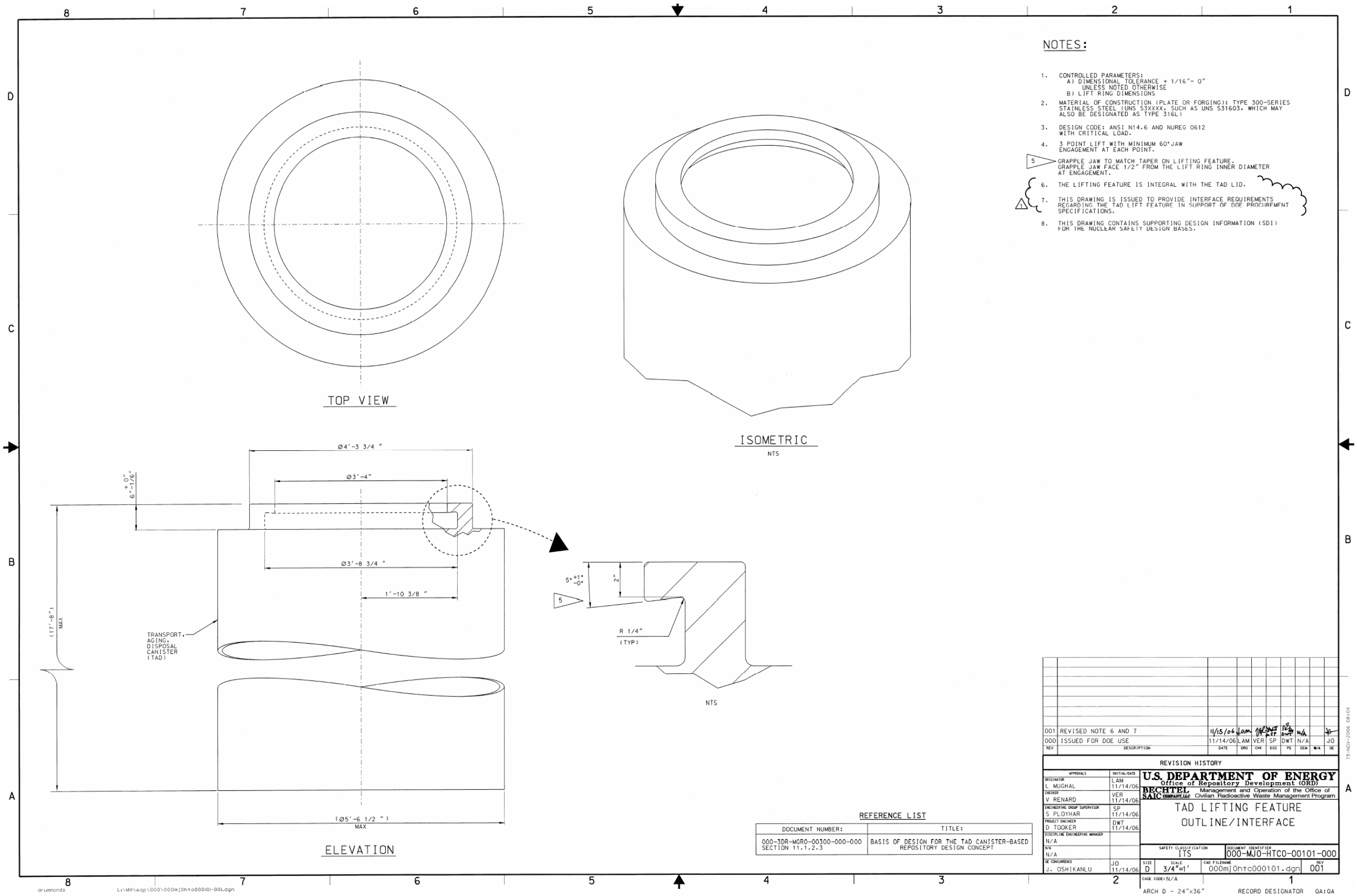

- NOTES:**
- CONTROLLED PARAMETERS:
 A) DIMENSIONAL TOLERANCE $+ 1/16'' - 0''$
 UNLESS NOTED OTHERWISE
 B) LIFT RING DIMENSIONS
 - MATERIAL OF CONSTRUCTION (PLATE OR FORGING): TYPE 300-SERIES STAINLESS STEEL (UNS S3XXX, SUCH AS UNS S31603, WHICH MAY ALSO BE DESIGNATED AS TYPE 316L)
 - DESIGN CODE: ANSI N14.6 AND NUREG 0612 WITH CRITICAL LOAD.
 - 3 POINT LIFT WITH MINIMUM 60° JAW ENGAGEMENT AT EACH POINT.
 - GRAPPLE JAW TO MATCH TAPER ON LIFTING FEATURE. GRAPPLE JAW FACE 1/2" FROM THE LIFT RING INNER DIAMETER AT ENGAGEMENT.
 - THE LIFTING FEATURE IS INTEGRAL WITH THE TAD LID.
 - THIS DRAWING IS ISSUED TO PROVIDE INTERFACE REQUIREMENTS REGARDING THE TAD LIFT FEATURE IN SUPPORT OF DOE PROCUREMENT SPECIFICATIONS.
 - THIS DRAWING CONTAINS SUPPORTING DESIGN INFORMATION (SDI) FOR THE NUCLEAR SAFETY DESIGN BASES.

REFERENCE LIST

DOCUMENT NUMBER:	TITLE:
000-3DR-WGRO-00300-000-000 SECTION 11.1.2.3	BASIS OF DESIGN FOR THE TAD CANISTER-BASED REPOSITORY DESIGN CONCEPT

REV	DESCRIPTION	DATE	CHK	EGG	PK	SEW	WKA	DK
001	REVISED NOTE 6 AND 7	11/15/06	LAM	VER	SP	DWT	N/A	JO
000	ISSUED FOR DOE USE	11/14/06	LAM	VER	SP	DWT	N/A	JO

REVISION HISTORY

APPROVALS	INITIALS/DATE
DESIGNER	L. MUGHAL 11/14/06
CHECKER	V. RENARD 11/14/06
ENGINEERING GROUP SUPERVISOR	S. PLOYHAR 11/14/06
PROJECT ENGINEER	D. TOOKER 11/14/06
RESOURCING ENGINEERING MANAGER	N/A
N/A	
OF CONCURRENCE	J. OSHIKANLU 11/14/06

U.S. DEPARTMENT OF ENERGY
Office of Repository Development (ORD)
BECHTEL Management and Operation of the Office of SAIC COMPANY, LLC Civilian Radioactive Waste Management Program

TAD LIFTING FEATURE
OUTLINE/INTERFACE

SAFETY CLASSIFICATION	DOCUMENT IDENTIFIER
ITS	000-MJO-HTC0-00101-000

SIZE: D SCALE: 3/4"=1' CAD FILENAME: 000mj0ht+c000101.dgn REV: 001
 CAGE CODE: N/A ARCH D - 24"x36" RECORD DESIGNATOR: QA:0A

**PAGE INTENTIONALLY
LEFT BLANK**

Attachment D

Aging Overpack Details

**PAGE INTENTIONALLY
LEFT BLANK**

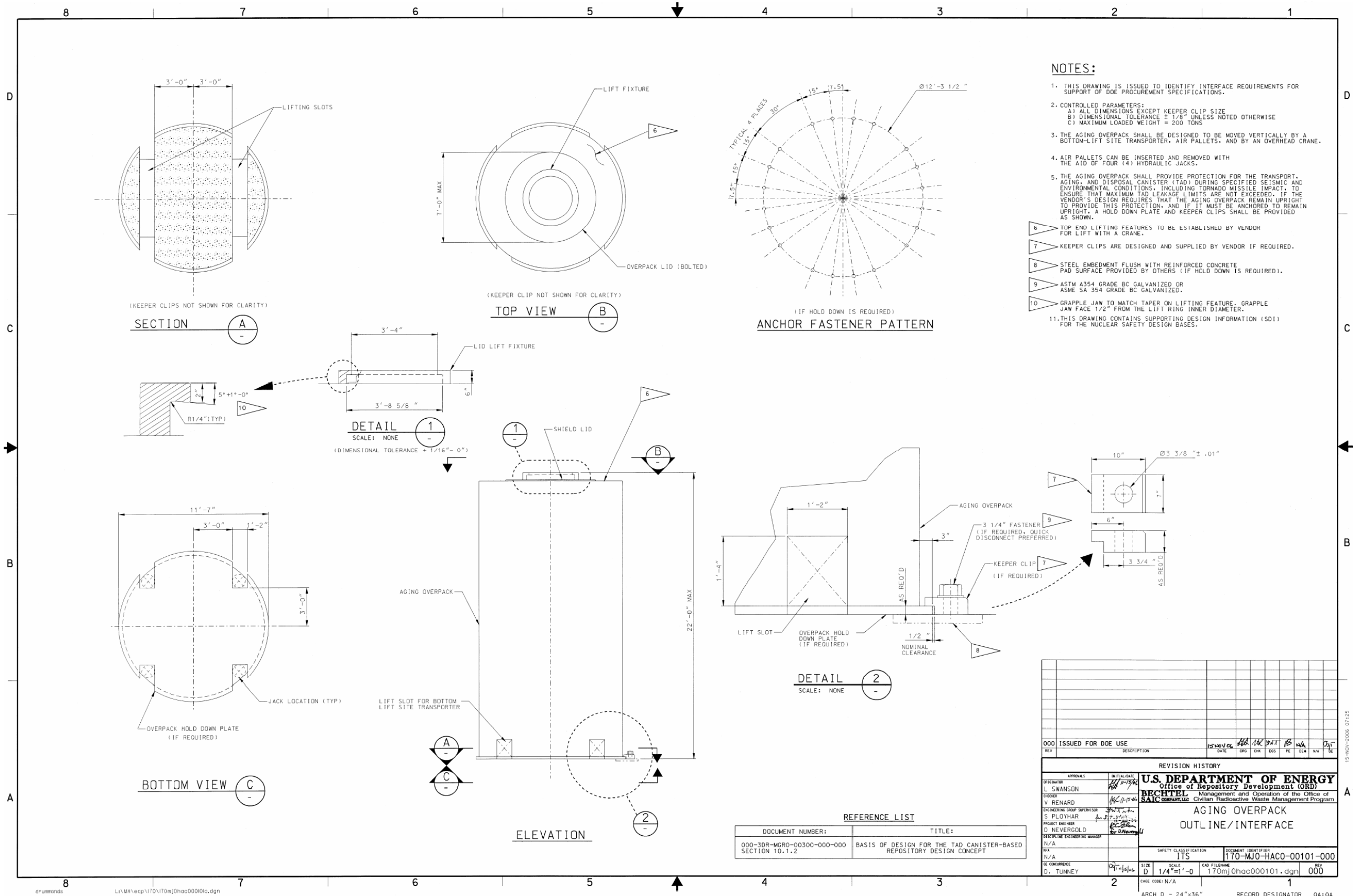

**PAGE INTENTIONALLY
LEFT BLANK**